



	Section
Introduction / Warranty / Body Construction	1
Motorhome Code	2
Preparing for the Road	3
On the Road	4
Arrival on Site	5
Safety & Security	6
Connection of Services	7
Technical Specification	8
Fitted Equipment	9
Care of your Motorhome	10
Useful Information	11
Service Section	12
Index	13

Copyright © 2010 Auto-Sleepers Ltd. All rights reserved.

No part of this document may be reproduced or transmitted in any form or by any means, electronic or mechanical, for any purpose, without the express written permission of Auto-Sleepers Ltd.



Welcome

Congratulations on your purchase of an Auto-Sleeper motorhome. We are confident it will give you many years of pleasure.

This handbook has been compiled to enable you to obtain the maximum pleasure from your vehicle. It contains the appliance instructions along with advice on safety matters.

Please read this Handbook thoroughly so that you are conversant with all the motorhome systems, operating instructions and precautions.

Failure to observe these recommendations or precautions may result in incorrect operation of equipment and subsequent risk to occupants.

Information leaflets and literature on safe operation of appliances and equipment fitted to your motorhome are included in the Auto-Sleeper Customer Pack. Please read these carefully prior to use.

Should you experience any difficulties contact your dealer who will be pleased to offer advice.

It is the policy of Mercedes and Auto-Sleeper to improve continually their vehicles, so whilst the details contained in this Handbook are correct at the time of going to press, they reserve the right to alter the specifications at any time without notice.

Auto-Sleeper motorhomes offer a variety of customer uses and whilst each vehicle features the optimum storage, fluid, seating and sleeping capabilities, it is the customer's responsibility to select the proper combinations of loads without exceeding weight capacities.

Your Auto-Sleeper motorhome conforms to the European standard EN 1646-1 for habitation requirements relating to Health and Safety.

IMPORTANT:

In the interests of safety, replacements parts for appliances must conform to the manufacturer's specification and should be fitted by them or an authorised agent.

Model

This Handbook covers the Mercedes Stanton, based on the Mercedes Sprinter 316 CDi short wheelbase chassis cab.

Gas System

The gas system is designed to operate on LPG stored in a re-fillable tank fitted underneath the vehicle. The regulator has a working pressure of 30 mbar.

Conversion Type

Coach-built conversion with four berths, comprising a transverse double bed at the front and either a fixed double or two fixed single beds in the rear bedroom. Laminated panel and glass-fibre combination. Insulated panels have GRP outer skin.

Climatic Conditions

This motorhome is designed for use in cold climates, and is certified to grade 3 in accordance with the European standard EN 1646-1: 2012. This means that it has been tested and shown to provide a comfortable internal environment even when the external temperature is as low as -15°C.

Handbook

Any queries should be addressed to your Auto-Sleeper dealer.

Appliance Instructions

The appliance instructions included have been extracted from those supplied from the appliance manufacturers.

Automotive - Mercedes

For all automotive matters you should refer to the Mercedes vehicle instructions manual. This includes tyre pressures, referring to the type of tyres fitted.

The Auto-Sleeper conversion does not affect the tyre pressures in any way as it is built within the design envelope of the base vehicle.

The tyre pressures for your vehicle can be found on a label located on the seat support below the driver's seat. Check the tyre size fitted to your vehicle and read off the appropriate information.



AUTO-SLEEPERS WARRANTY

Warranty Registration

The supplying dealer's representative and the purchaser must sign the declaration in the Warranty/Service book to verify that the dealer has explained the warranty terms and conditions and that the purchaser understands them.

The dealer must then register the sale on the Auto-Sleepers warranty system to activate the cover.

Warranty Terms and Conditions

For full details of the warranty terms and conditions, please refer to the Warranty/Service handbook supplied with your Auto-Sleeper.

Contact Us

You may contact us at:

Auto-Sleepers Limited,
Orchard Works,
Willersey,
Nr Broadway,
Worcestershire
WR12 7QF

Tele: 01386 853338

Fax: 01386 858343

E-mail: aftersales@auto-sleepers.co.uk

Internet: www.auto-sleepers.co.uk

To enable us to deal with your queries efficiently, always quote your vehicle's production number, which can be found written on a label in the glovebox and on the bottom edge of the Type Approval plate fitted to the driver or passenger door pillar.

**BODY CONSTRUCTION:**

Side Walls: GRP - Silver Grey RAL9006.

Floor Vinyl: Limewash.

Furniture: Valencia (Amarti option).

Furniture Fittings: Chrome.

Work Surfaces finish: Slate Wraky.

Table finish: Slate Wraky.

Carpet: Jute.

Upholstery: Catalan or Moonstone, various colours.

Curtains/Cushions: To match upholstery colour.

Exterior Graphics: BS1850.



THE COUNTRY & COASTAL CODES

Upon arrival at your destination you should be aware of the Country Code relating to motorhome owners. This is entitled the *Motor Caravanners' Code*.

Code of Conduct - Camp Sites

Arrivals

- Report to reception immediately on arrival.

Vehicle Movement

- Keep to roadways unless otherwise directed.
- Adhere to speed limits. Note that these are generally 10 mph. (Remember that the stopping distance on grass is considerably greater than on tarmac).
- Only a person in possession of a current driving licence may drive on the site.
- Park correctly as advised on your pitch. Where possible leave 20ft of free space around your vehicle.

Use of Site

- Use the electrical mains hook-up in the correct manner and with caution.
- Ensure that all fresh water taps/connections are turned off after use.
- Have care and consideration when using all facilities (toilets and showers etc.) and leave them clean and tidy. Young children should be escorted.

To avoid possible damage to sewage purification works, only approved chemical fluids must be used. Under no circumstances may coal tar, phenol or caustic-based fluids be used. Disposable napkins and similar bulky items must not be put into chemical closet emptying points but should be wrapped in a polythene bag and placed in the container provided. (Put all litter in containers marked for the purpose).

Noise

- Do not make excessive noise.
- Children should be restrained from making excessive noise.

- Flying kites and model aircraft and the use of items like catapults or air-guns as well as ball games should not be permitted among, or close to, motorhomes.
- Musical instruments, record players, radios and televisions should not be used to the inconvenience of other people on site.
- Open and close doors quietly.
- Power generators must be adequately silenced and used with consideration and according to restricted site times.

Dogs and Pets

- All dogs and other pets should be kept under control.
- Unless permission has been granted, no animal should be allowed loose on the site and leads must not exceed 10ft.
- No animal should be allowed in the shower/toilet blocks.
- Do not let dogs foul the site.

Fire Precautions

Adhere to and make note of all fire precautions concerning the whereabouts of the fire points.

Although not compulsory, it is recommended that a 1 kg (2lb) dry powder fire extinguisher is carried. It should comply with BS 5423 and be marked BSI or FOC approved. It is important to check at regular intervals that the extinguisher is working as is required by types meeting BS 5423.

Careful thought is necessary for the positioning of the extinguisher, which should be near the door but not too close to the cooking equipment where sudden flames could make it unreachable. In the kitchen area, a fire blanket is a worthwhile precaution.

Unless permission has been granted, barbecues should not be used. When permission has been given, consideration should be given to the annoyance that can be caused to other users of the site. Open fires are not allowed.



Awnings and Tents

Awnings and tents should only be used when permission has been obtained.

When on grass and staying for more than a few days, the ground sheet and/or side flaps of awnings should be periodically raised in order to avoid damage to the ground.

Departure

- Leave the pitch clean and tidy.
- On leaving, check out with the reception paying the required dues.

Wild camping

Camping away from licensed sites, without the permission of the landowner or his agent, is not allowed in the United Kingdom. When permission has been granted, all aspects of this Code should be adhered to.

On no accounts should:

- Litter be disposed of other than in receptacles provided.
- Water be allowed to escape from the vehicle.
- Chemical toilets be emptied except into the disposal places agreed with the landowner.
- Washing or similar be hung outside the vehicle.

Parking

Motorhomes should only be parked in approved places.

When using the facilities of a motorhome at such times, care and consideration should be given to those around them.

Driving

When using a motorhome on either the public highway or private road, the Highway Code should be complied with and full consideration given to other road users.

In the event of a motorhome travelling slowly and there being a queue of traffic behind, the driver of the motorhome should, where possible, pull over in order to let the other traffic pass.

When the vehicle is in motion it is compulsory

that all passengers are seated and seat restraint straps worn.

Before moving off, elevating roofs **MUST** be lowered and correctly secured, and top hinged windows closed. Likewise all doors and access lockers for gas containers and chemical toilets must be properly closed.

Exterior steps should be properly retracted and secured.

When the vehicle is being refuelled, or on a ferry, all gas systems must be turned off.

Gas appliances should only be used when the vehicle is in motion when the manufacturer of the appliance permits such use.

Handbook

Before using a motorhome all aspects of the handbooks produced by the chassis manufacturer and the converter must be read and adhered to.

Environment

Care and consideration should be taken to protect the environment.

Observe the Country and Coastal Codes shown below:

The Country Code

Enjoy the countryside but respect its life and work.

More people than ever before are exploring the countryside, interested in farming, plant life, bird watching or just observing the general wildlife. Whatever your interest, there is a lot to learn, but please observe the following code.

Guard against all risk of fires. Hay and heath land catch alight easily and once ablaze are very hard to put out. *Remember: Fire Spreads Quickly.*

- Keep to public paths across farmland.
- Use gates and stiles to cross fences, hedges and walls.
- Leave livestock, crops and machinery alone. View from a distance.
- Take your litter home - it is unsightly and harmful to wildlife.



- Help to keep all water clean.
- Take special care of country roads.
- Make no unnecessary noise. Most animals are very timid, noises can disturb them unnecessarily. If you want to get the best out of the country, go quietly.

The Coastal Code

As our coastlines are increasingly used for recreation and education, the following suggestions are made to enable us to enjoy our inheritance and preserve it for posterity.

- Do not trample about, or move rocks unnecessarily.
- Do not frighten seals or seabirds.
- Do not spear fish.
- Do not spill detergents, solvents or fuel from boats as these can kill marine life.
- When sailing, moderate your speed - the wash from a fast boat can destroy banks and nests.
- Live mollusks and crustaceans need not be collected as souvenirs - dead shells can usually be found.
- Shellfish can take years to grow and fines can be imposed for not observing national regulations.
- Do not pull up seaweed unnecessarily.
- Make your visit instructive - not destructive.
- Look at material, don't remove it. Take notes and photographs, not specimens.
- Observe bye-laws and be considerate to others.
- National Trust property or Country Parks have regulations to protect the wildlife. Follow these.

Fire Precautions

You should also make yourself aware of the local fire regulations.



YOUR MOTORHOME (Weights explained)

Mass in Running Order (MRO)

The weight of your motorhome as it leaves the factory, as new with standard fixtures and fittings, plus an allowance for driver and 90% fuel.

Maximum Technically Permissible Laden Mass (MTPLM)

The maximum weight of the vehicle when fully laden for use on the road. See specification section for actual figure.

User Payload

The load margin (payload), this represents the difference between the Mass in Running Order (MRO) and the Maximum Technically Permissible Laden Mass (MTPLM). It shows the maximum weight which can be loaded into your motorhome, covering items such as food, crockery, cutlery, clothing, bedding, gas cylinders, etc. See Technical Specification for actual figure.

Please take care to ensure that you have allowed for the masses of all items you intend to carry in the motorhome, e.g. passengers, optional equipment, essential habitation equipment and personal effects such as clothing, food, pets, bicycles etc.

Although there may be additional seat belts within the motorhome, please refer to the stated number of passengers that are allowed due to the MRO and MTPLM.

LOADING AND DISTRIBUTION OF WEIGHT IN THE MOTORHOME

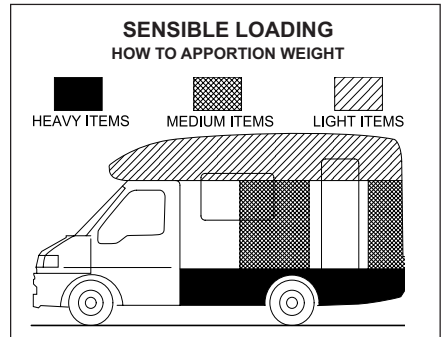

Loading

Correct weight distribution is a major factor in making your motorhome a balanced and pleasant vehicle to drive without compromising road-holding. Care should therefore be taken to ensure that heavy items are well spaced and are in as low a position as possible, for example, low cupboards and bed boxes.

DO NOT EXCEED THE STATED MAXIMUM LOAD. ITEMS FITTED OTHER THAN STANDARD EQUIPMENT WILL DEplete THE PAYLOAD STATED IN THIS HANDBOOK.

WARNING: Under no circumstances should the maximum permissible laden mass of the motorhome be exceeded.

Roof Loading

DO NOT ALLOW CHILDREN TO CLIMB ONTO THE ROOF.

WARNING: Take special care when on the roof in wet or frosty weather conditions, which cause it to be particularly slippery.

Maximum load on the roof, whether a fixture or person, should not exceed 75 kgs (165 lbs) with a maximum loading of 8 kg (17 lbs) per square foot.



Before Moving Off

Whenever making a journey with your motorhome, either setting off on holiday or returning home, it is good practice to run through this simple checklist.

1. Close and secure all cupboards and drawers and check any loose articles. Do not store tins, bottles, etc. in overhead lockers.
2. Close and secure all windows and roof lights.
3. Leave all curtains and blinds open to aid visibility.
4. Turn off all gas appliances, except those heating appliances designed to function while the vehicle is in motion. Ensure that the red isolation taps are in the 'off' position.
5. Ensure that there is sufficient gas to meet your needs.
6. Switch off 230 volt supply at source, disconnect mains cable from site supply before disconnecting from vehicle. Beware of potential electric shock from wet cable. Coil cable and store in a safe place.
7. Check your RCD's/MCB's for operation.
8. Check and if necessary, charge the habitation battery.
9. Check battery selection switch is in the OFF position.
10. Check that the battery is secure and that the battery box lid is fastened.
11. Ensure the fridge is on 12V operation and door lock is set. (**Note:** the electrical relays will allow the fridge to be run on the vehicle battery when the engine is running.)
12. Remove any external fresh water connections etc.
13. Make sure any heavy articles are stored in accordance with the loading procedure. Tables should also be made secure.
14. Lock the motorhome exterior door (remember to take out your keys).
15. Check your external rear view mirrors and adjust if necessary.
16. Check that all corner steadies are wound up and that, if a step is used, it is put away before moving off.
17. Check wheel nuts are secure and tyre pressures are correct.
18. Ensure, if required, that your fresh water tank is full and your waste tank is empty.
19. Referring to your base vehicle manual, check all fluid levels including automotive fuel and tyre pressures. Remember to check that your spare tyre is of the recommended pressure.
20. Ensure that, on models fitted with an elevating roof, the roof is securely locked down with the exterior catches applied.
21. The fridge vent covers should be fitted when the vehicle is to be driven in order to comply with European Type Approval regulations for vehicle external projections.
22. Ensure that the toilet flush tank only contains a small amount of water (1-2 litres) in order to minimise the risk of leaks or spillage whilst the vehicle is in motion.
23. Check underneath the vehicle for stray items.
24. Safely store levelling blocks away in an appropriate place.



Pulling Off

Engage the clutch smoothly.

Avoid wear and tear on clutch and transmission by taking extra care.

Change gears smoothly.

Try not to jerk the clutch.

MOTORWAY DRIVING

Speed Limits (UK)

If a speed limit is not in force, your motorhome can be driven up to 70mph on motorways and dual carriageways.

1. Reduce Speed:
 - i) In high or cross winds.
 - ii) Downhill.
 - iii) In poor visibility.
2. High sided vehicles cause air buffeting, so extra care must be taken when passing or being passed. As much space as possible should be given.

Motorway Handling

Do not bump the kerb with the wheels.

When passing other vehicles allow more than the normal clearance.

Allow longer to get up speed to pass.

Do not swing out suddenly.

Carry out all manoeuvres as smoothly as possible.

Use nearside wing mirror to check motorhome has cleared when overtaking.

Spare Wheel

CAUTION: Familiarize yourself with this section prior to driving the vehicle and take careful note of the warnings given.

Your Mercedes may be fitted with a spare wheel, located under the vehicle behind the rear axle, or a tyre sealant system to seal small punctures, particularly those in the tyre tread. The tyre sealant system is located in the stowage compartment in the right hand door sill.

For full instructions on how to use the tyre sealant, refer to the Mercedes handbook supplied with the vehicle. Look in the index at

the front of the book for the section entitled 'Spare wheel' or 'Tyre sealant' which gives full details of the correct procedure to follow.

After using the sealant, drive to the nearest workshop, at a maximum speed of 50 mph, to have the tyre repaired or replaced.

Rear Step

On moving off the rear step retracts automatically. In the event of the rear step being left extended, a buzzer, positioned behind the dashboard, will sound (when the ignition is switched on) - and will continue to do so until the rear step has been fully retracted.

Changing a Light Bulb

The front and rear marker lights, the side marker lights (where fitted) and the high level brake light, are LED type and should not normally require any attention.

To change other rear light bulbs, ease the lamp from the back panel by pushing up the metal tag at the bottom of the lamp with a screwdriver. Withdraw the lamp and undo the over-centre clip to release the bulbholder. Change the bulb and re-assemble, ensuring that the over-centre clip snaps into its retaining slot. Replace the lamp in the back panel, ensuring that it is the correct way up, with the retaining clip at the bottom.

Cycle Rack & Rear Ladder

In order that a cycle rack, and/or a rear ladder, can be fitted, the rear panel bodywork is reinforced in certain areas. Vertical and horizontal timbers have been bonded into the panel to take the fixings for these items.

If required a drawing showing the positions of these timbers may be obtained from our Service Department.

Note that a folded cycle rack or rear ladder will increase the length of your vehicle by up to 400 mm.



Whilst Driving

Whilst the vehicle is being driven ensure that:

- Both the passenger and driver wear seat belts - this is a legal requirement.
- Heavy loads are not stored in top cupboards or in areas from which they may become detached. Please ensure that heavy items are stored low down and take care not to overload individual wheels, the axles or the MTPLM.
- Table(s) are stowed in the correct position and table legs secured in their retaining clips.
- Furniture lids are lowered; cupboards and flaps are closed and secured.
- The refrigerator door is closed and secured by its travelling catch.
- The retractable rear step if fitted, is folded away or, if a separate step is supplied, it is safely stowed in the vehicle.
- Roof ventilators are closed and locked in the down position.
- The bathroom is not used whilst the vehicle is in motion.
- Top hinged windows are closed, and securely fastened.
- Children do not roam around the vehicle; they may fall and injure themselves.

Front Seat Swivel (where fitted)

Your vehicle may be fitted with a swivel base to either or both of the front seats, so that they may be turned to face the rear of the vehicle. The release handle, coloured red, is located on the inside of the seat and is moved rearwards to unlock the swivel mechanism.

Note: It may be necessary to lower the handbrake in order to swivel the driver's seat. In this case, ensure that first gear (or Park) is engaged and the road wheels are chocked first.

WARNING: It is important that while the vehicle is in motion, any seat swivels are locked in the forward facing position.

Map Storage

In the rear of each cab seat there is a map pocket for storage of maps, periodicals and light items.



CHECK SITE REGULATIONS

Siting your Motorhome

When siting your motorhome, keep to the roadways unless otherwise directed. Obey the speed limit which, in general, is 10 mph. Only a person in possession of a current driving licence is permitted to drive on the site. Stopping distances on grass are considerably greater than on tarmac.

Selecting a Pitch

Carefully select where you wish to park your motorhome. The site should be as level as possible, well drained and away from boggy areas and, preferably, not under or near trees. Consider also, how you will move your motorhome when leaving the site. For example, on sloping ground in wet conditions, pitch facing downhill.

Levelling

The optional rear corner steadies, which can be lowered by using the brace supplied, are designed to give greater stability to the vehicle when it is stationary on site.

Note: On no account should the rear corner steadies be used to jack up the vehicle when carrying out maintenance or changing a wheel.

It is important to site your motorhome level to ensure correct operation of the refrigeration, cooker, etc, by using purpose made ramps and NOT bricks or such items.

Awning Light

The exterior awning light is controlled by a button on the electrical control panel, see page 7-18.

Fridge Vent Covers

Remove the fridge ventilation covers (if fitted) from the outside vents, by turning the screws anti-clockwise and pulling the covers gently outwards from the bottom. Store in a safe place and replace in the reverse fashion, prior to driving on public roads as noted in section 3.



SAFETY

Important: Your attention is drawn to the notice affixed in the motorhome advising on fire prevention, ventilation and what to do in case of fire.

Children

Do not leave children alone in the motorhome in any event, keep potentially dangerous items out of reach as at home. e.g. matches, drugs, etc.

WARNING: When upper bunks are used by children especially under six years of age care shall be taken against the risk of them falling out.

Fire Extinguishers

It is recommended that a 1 kg (2lb) minimum capacity dry powder fire extinguisher be located by the main exit door at all times.

A fat pan fire should not have an extinguisher aimed at it but be smothered with a fire blanket (which should be stored by the cooker).

In case of fire

1. Get everyone out of the motorhome as quickly as possible using whichever exit is the quickest including windows. Do not stop to collect any personal items.
2. Raise the alarm — Call the fire brigade.
3. Turn off gas container valve if safe to do so.

Ventilation and Condensation

The ventilation points on your motorhome are fixed points of ventilation which are stated by the European Standards. Under no circumstances must these vents be blocked or obstructed. It is advised that fixed ventilation points and any protective screens are checked and cleaned (if necessary) on a regular basis.

Fresh air circulation should be allowed below the motorhome when appliances are in use and when flues terminate below the floor to allow free evacuation of the products of combustion. At least three sides of the underfloor space should always be kept open and unobstructed especially by snow. Do not make any additional openings in the floor.

Under no circumstances must these vents be blocked or obstructed.

Additional night time ventilation is obtained by releasing the window catches and placing them in the second groove on the frame catch.

Awnings

There is no danger of pollution of an enclosed awning space by the LPG exhaust from the refrigerator venting into it.

WARNING: Space heaters may produce sufficient exhaust gases to pollute the awning space if it is totally enclosed (from a general comfort, smell, and hygiene point of view). In the extreme case, there could be a build up of carbon dioxide to a dangerous level.

Note: Motorhome owners are advised to allow some fresh air circulation into the awning space when such appliances are in use. It should be noted that the space heater exhaust terminates on the offside of the vehicle.

Air Bags

Front airbags are fitted to both the driver and front passenger seat positions. Note that the passenger airbag cannot be disabled, therefore, a rearward facing child seat should not be fitted on the front passenger seat, as indicated by the special sticker on the side of the dashboard. For further information please refer to the base vehicle owner's handbook.

Child Seats

For advice on the fitment of child restraint systems, please refer to the base vehicle owner's handbook.



ELECTRICAL SYSTEMS

Batteries

Battery terminals and connectors should be firmly attached. Battery surfaces should be free of moisture and dirt.

Where removable cell taps are fitted these must be screwed firmly home.

When removing a battery always remove the negative cable first. On re-connection the negative cable should be connected last. Switch off all lamps and appliances before disconnecting the battery. Do not smoke while working on or near to the battery.

Fuses

Always replace blown fuses with one of a correct rating.

Overload

Never overload any electrical circuit, especially the 12-volt socket outlet. The rating of appliances should be checked before connection.

Shower Compartment Light

Ensure that water does not ingress into the light unit.

Charger Unit

Keep the charger unit well ventilated and never allow material or bags to be in contact with the unit casing which gets hot when the unit is operating.

230 Volt Mains Operation

Before connecting to the supply, ensure that the contacts in both the plug and the socket are clean and dry and that the hook-up plug is firmly located and locked into the socket. The RCD must be easily accessible at all times.

GENERAL

Before using your Auto-Sleeper, you should be fully conversant with the following safety precautions; if you are in any doubt as to the meaning of any of them you should contact your supplying Auto-Sleeper dealer. Please read the following carefully.

In the interests of safety, replacement parts for appliances should conform to the appliance manufacturer's specification and should be fitted by them or their authorised agent.

WARNINGS:

- 1 Never use portable cooking or heating equipment, other than electric heaters that are not of the direct radiant type, as it is a fire and asphyxiation hazard.**
- 2 Do not use cookers as heaters or dry clothes etc on the cooker or space heater.**
- 3 Make sure that combustible materials can not come into contact with hot surfaces or burners.**
- 4 Surfaces of appliances may become hot in use and the guard provided does not give full protection to the young and elderly.**
- 5 Do not use additional independent gas appliances inside the vehicle.**
- 6 Never allow modifications of electrical or LPG systems or appliances except by qualified technicians.**

The water heater fitted to this vehicle is of the "room sealed" type, any replacement should be the same, i.e. "room sealed".

Turn off all gas equipment and cylinders/tanks and any other heating appliances before travelling.

Ventilation openings are located below all the gas appliances. In winter conditions make sure the vents are clear of snow and mud. These openings should be regularly checked and any mesh covering them cleaned with a stiff brush to prevent any risk of them becoming blocked. The openings are provided for your safety - please do not obstruct them.



Smoke Alarm

A Fire Angel battery operated smoke alarm is fitted to your vehicle. Please read carefully the manufacturers instructions supplied in order to understand it's operation.

Features

- Battery operated.
- Operating light (LED) flashes approximately every 40 seconds confirming unit is powered.
- Low battery warning. Unit "beeps" approximately every 40 seconds for up to 7 days when the battery needs replacing.
- Sensitivity test button. Tests sensitivity, circuitry, battery, horn.
- Loud 85 decibel Piezo electric alarm. Automatically resets when hazardous condition has passed.
- Smart Silence, which enables you to temporarily silence your alarm for 10 minutes whilst cooking in order to avoid unnecessary alarms.

WARNING: Test smoke alarm operation after vehicle has been in storage, before each trip and at least once per week during use.

Your alarm requires one 9 volt battery. Under normal use, the battery should last approximately one year.

Simple maintenance

Gently vacuum the outside of the alarm every three months using a soft brush to help keep the unit working efficiently.

Problems are indicated by two events:

1. The alarm does not sound upon pressing the test button.
2. The alarm chirps intermittently.

Try the following:

1. Inspect for obvious damage.
2. Visually check that unit contains recommended battery type.
3. Check that battery is properly connected.
4. Gently vacuum as recommended above.
5. Replace battery.

If these procedures do not correct the problem, do NOT attempt repairs. Contact the manufacturer.

Carbon Monoxide Alarm

A Fire Angel battery operated Carbon Monoxide Poisonous Gas alarm is fitted to your vehicle. Please read carefully the manufacturers instructions supplied in order to understand it's operation.

Features

- An advanced electrochemical sensor designed to accurately measure low levels of carbon monoxide (CO) providing an early warning of toxic CO levels in your motorhome.
- Detects carbon monoxide continuously.
- Resistant to false alarms caused by normal household contaminants.
- Sounds a loud 85dB alarm (at 3 metres/ 10 feet) to alert you in case of an emergency.
- Test/Reset button.
- Regular self-check to ensure detector is operating correctly.
- Simple to mount, portable, ideal for travelling.
- Certified to European Carbon Monoxide Alarm Standard BS EN 50291:2001.
- Seven year limited warranty (batteries excluded).

Power Pack Activation

- Your detector comes complete with an integrated power pack that will provide power for its entire operational life. To activate the power pack you need to pull the disabling tab (see Fig 1). This will in turn pull out the metal disabling clip, which is attached to the end of the tab, from the disabling socket which is situated on the underside of the detector. Retain the disabling tab for future use.
- When the detector is activated the Power LED will begin to flash green once every minute to indicate that the detector is receiving power from the power pack and is fully operational.
- Test the sounder, power pack and circuitry by pressing and holding the

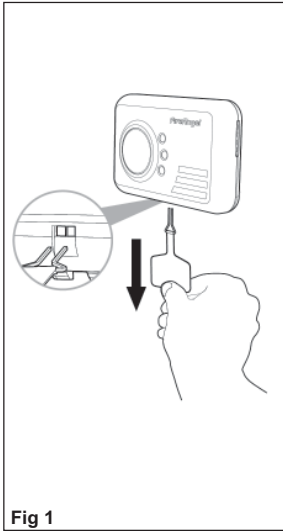

Fig 1

centre of the Test/Reset button briefly to confirm that the detector is operating properly. The sounder will sound as soon as the button is pressed and the Alarm LED will illuminate red indicating that the sounder is working and the power pack is

providing power to the unit. This test for the sounder, power pack and circuitry should be performed on a weekly basis. This should be continued for the lifetime of the product.

WARNING: Prolonged exposure to the sounder in close proximity to your ears may damage your hearing.

Under normal operating conditions the power pack will last for the lifetime of the product, ie. 7 years.

The detector will not protect against the risk of carbon monoxide poisoning when the power pack has drained.

WARNING: Prolonged exposure to extreme high or low temperature may reduce the life of the power pack.

Power Pack Deactivation

Your CO-9X is portable, making it ideal for taking with you on holiday. You will need to deactivate your detector when travelling or even when storing e.g. when decorating. Fitting is the reverse of removal. To deactivate the detector the two ends of the metal clip must be inserted into the corresponding holes in the disabling socket located on the underside of the detector (see Fig 2). You can ensure that the product is

disabled by pressing the test button - if there is no sound from the sounder then the clip has been fitted correctly.

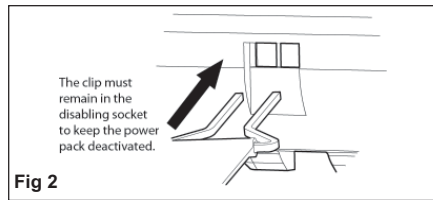

Fig 2

Note: If the disabling tab is no longer available then the clip can be replicated by opening out a thin metal paper clip into a U-shape.

Operating Features

Your FireAngel detector offers many features which set it apart from other CO detectors on the market today.

Test/Reset Button Feature

This button will:

- Test the sounder, power pack and circuitry.
- Allows you to test the sensor by introducing a source of CO into the detector (see 'Testing The Sensor').
- Silence the loud 8.5dB (at 1 metre (3 feet)) sounder during an alarm (only for alarms due to levels of CO of less than 50ppm)

Testing the sounder, power pack and circuitry

Test the sounder, power pack and circuitry by pressing and releasing the Test/Reset button to confirm that the detector is operating properly. The sounder should sound as soon as the button is pressed, and the Alarm LED will illuminate red indicating that the sounder is working and the power pack is providing power to the unit. This test for the sounder, power pack and circuitry should be performed on a weekly basis.

Testing the sensor

Note: We suggest the use of an incense stick or cigarette as the inefficient way in which these products burn means the smoke given off contains a detectable localised amount of carbon monoxide. Alternative sources of



smoke, for example an extinguished candle or match, will not contain sufficient levels of carbon monoxide to obtain a response from the detector during this test. Please note your CO detector will not detect smoke.

CAUTION: Sensor testing should only be performed by a responsible adult. This test should be performed annually.

Note: CO test kits may be used in order to avoid having to burn cigarettes, incense sticks etc. However we recommend that incense sticks are used as they are cheap and readily available.

Read all steps thoroughly before attempting to test the sensor.

- Step 1 If the detector is wall or ceiling mounted unhook the detector from the screws.
- Step 2 Cover the sounder vents with one hand. Press and hold the Test/Reset button down with your thumb/finger until the Fault LED illuminates yellow and the sounder sounds for a second time (this should happen after around 5 seconds). Release the Test/Reset button. Upon releasing the Test/Reset button the Fault LED will flash yellow once every second. This indicates that the sampling rate of the detector has increased and can be tested using a known source of CO.

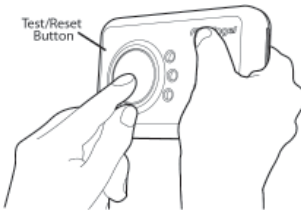

- Step 3 Light a cigarette or an incense stick using a match or lighter. If using an incense stick be sure to blow out the flame so that the incense stick is smouldering. Extinguish the lighter, or put out the match and place it into a dish of water.

- Step 4 Turn the detector on its side so that the vents on the right hand side of the detector are pointing downwards. Hold the burning cigarette or incense stick 15cm (6 inches) below the detector, so that the smoke enters the vents on the side of the detector. An increase in the localised carbon monoxide level with the sensor to more than 50ppm will cause the sounder to sound for one cycle of four loud beeps and the Fault LED to illuminate yellow for a short time. This is the end of the test. The Fault LED will no longer flash yellow and the detector will go back to normal operating mode ie. the Power LED will flash green once every minute (It may take up to two minutes of exposure to the smoke for the localised level of carbon monoxide within the sensor to reach over 50ppm). Now move the source of CO away from the detector as the test is finished.

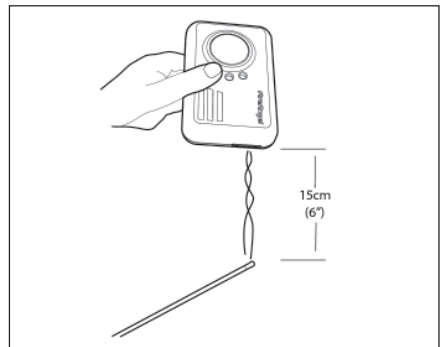

- Step 5 After step 4, put out the incense stick or cigarette by placing it into a dish of water. Ensure that all flames have been extinguished.

Note: If the localised carbon monoxide level within the sensor does not reach 50ppm during the test, the sensor test will stop automatically after 3 minutes.



Understanding the Product's Indicators

The higher the concentration of carbon monoxide detected by the detector, the quicker it will respond. When sufficient carbon monoxide is detected a loud audible signal (85 dB at 1m (3 feet)) will be emitted and the Alarm LED will flash red once every second.

The Alarm will sound:

- Between 60 and 90 minutes when exposed to a minimum of 50ppm of CO.
- Between 10 and 40 minutes when exposed to a minimum of 100ppm of CO.
- Within 3 minutes when exposed to a minimum of 300ppm of CO.

Fault/low power pack signal:

The unit continuously checks the settings of its sensor and circuitry. If any of these settings are found to be incorrect or if the power pack becomes low then the detector will emit a single chirp once per minute and the Fault LED will flash yellow once per minute for up to 30 days.

IMPORTANT: This does NOT mean that the detector has detected carbon monoxide.

If the product is still within warranty then contact technical support. If the product is no longer in warranty replace immediately!

IMPORTANT: The selected power pack was chosen to provide power beyond the lifetime of the product, in particular the sensor (under normal operating conditions). The sensor life is seven years, for this reason, the detector should be replaced after seven years from the date of installation.

FireAngel Technical Support Line

9.00am - 5.00pm, Monday - Friday

Telephone: 0800 141 2561

(1-800 523171 in EIRE)

e-mail: technicalsupport@fireangel.co.uk

Maintaining/Testing Your Detector

Maintenance

Your detector will alert you to potentially hazardous CO concentrations in your home when maintained properly. To maintain your FireAngel detector in proper working order

and to ensure that the sensor will last for the lifetime of the product, it is recommended that you:

- Test the sounder, power pack and circuitry of your detector at least once per week by pressing the Test/Reset button briefly.
- Perform the Sensor Test annually.
- Keep the detector free of dust by gently vacuuming the case with a soft brush attachment when required.

To prevent the possibility of contaminating the sensor in your detector and thus affecting its reliability.

- Never use cleaning solutions on your detector. Simply wipe with a slightly damp cloth.
- Do not paint the detector.
- Do not spray aerosols on or near the detector.
- Do not use any solvent based products near the detector.
- Move the detector to a safe location and store in a plastic bag before painting, wall papering, or performing any other activities using substances that emit strong fumes. Remember to remove it from the bag and replace the detector when these activities are finished.

Failure of any test should be reported to the technical support line.

Do not attempt to repair your CO detector. Do not remove any screws or open the main casing of your detector. Any attempt to do so may cause malfunction and will invalidate the warranty.

What to do in the event of an alarm

WARNING: A loud alarm is a warning that unusually high and potentially lethal levels of carbon monoxide are present. Never ignore this alarm, further exposure can be fatal. Immediately check residents for symptoms of carbon monoxide poisoning and contact the proper authorities to resolve all CO problems. **NEVER IGNORE ANY ALARM.**



Please carefully review this owner's manual to ensure that you know what actions to take in the event of an alarm.

What to do during an alarm

- Keep calm and open the doors and windows to ventilate the property.
- Stop using all fuel burning appliances and ensure, if possible, that they are turned off.
- Evacuate the property leaving the doors and windows open.
- Ring your gas or other fuel supplier on their emergency number; keep the number in a prominent place.

Write your fuel supplier's emergency number here:

- Do not re-enter the property until the alarm has stopped. When exposed to fresh air it can take up to 10 minutes for the sensor to clear and the alarm to stop depending on the level of carbon monoxide detected.
- Get medical help immediately for anyone suffering the effects of carbon monoxide poisoning (headache, nausea) and advise that carbon monoxide poisoning is suspected.
- Do not use the appliance again until it has been checked by an expert. In the case of gas appliances the engineer must be registered.

SECURITY

Chassis number

Record the chassis number and the factory job number of your motorhome, and keep them in a safe place at home.

The chassis number is a 17 digit number, beginning with the letters WDB, and is found on a plate located at the base of the driver's seat. The chassis number is also shown on the type approval plate, attached to the driver's door pillar, along with the permissible weight data.

The factory job number is an alphanumeric code consisting of a letter followed by four numbers, and is found on a label inside the glove box.

Motorhome Theft

The theft of a motorhome can occur in the most unlikely circumstances; from a motorway service area, even from an owner's driveway.

Secure all windows and doors when your motorhome is unoccupied even if only for a short length of time.

Additional security

Consider fitting any device which might deter or prevent intrusion by thieves. A wheel lock prevents removal of the wheel.

Window etching of the chassis number is a cost effective deterrent.

Free crime prevention

Advice about securing your motorhome, protecting your valuables, property marking, either at home or whilst on site, can be obtained from the Crime Prevention Officer through your local Police Station.

Central Locking

WARNING: Possibility of lock-out.

Please note that the Mercedes security system has a feature which re-locks all the doors (including the habitation area door) within 40 seconds of them having been unlocked unless one of the cab doors has been opened.



Under a specific circumstance - the owner is inside the vehicle, unlocks it using the remote control and exits via the habitation door without opening a cab door - the security auto relocking remains active. This results in the central locking system relocking the habitation door after 40 seconds and can leave an unwary owner locked out of his vehicle.

In order to avoid this possibility, always take the keys when exiting the vehicle. In any event, we would always advise the keys must never be left in an unattended vehicle no matter how close to it the owner intends to remain.

Of course, there is no need to take the keys if someone remains inside the vehicle.



Please read and become familiar with operating instructions for equipment fitted in your motorhome.

Connection of services are dealt with under separate headings, Water, Electricity and Gas.

WATER SYSTEMS

Fresh/Waste Tanks

The freshwater tank is located behind the offside skirt ahead of the rear axle, and may be drained using the blue tap positioned behind it. The waste water tank is positioned in the centre of the vehicle behind the rear axle, and is drained by a grey tap located behind the offside rear wheel.

For capacities of both see the Technical Specification Section.

The freshwater tank is filled through either the Whale socket or the lockable cap on the side of the vehicle. A special filler hose is supplied for use with the Whale socket.

All tanks and pipework are manufactured to food grade material specification..

Breathers

Both tanks are fitted with breathers, which allow air displacement when filling. When

filling the fresh water tank, water may escape through these breathers; this should give no cause for concern.

Frost Precaution

If the vehicle is not being used during freezing conditions the water should be drained. If the vehicle is being used in such conditions, refer to section 9 for details of the automatic draining of the heater and use of the water tank heaters.

FRESH WATER PUMP

A Whale submersible water pump is fitted in the freshwater tank of your vehicle. This is a compact, self venting, high flow pump which is quiet in operation and has a maximum flow rate of 15.8 litres per minute.

Maintenance

The pump is a sealed unit so no maintenance is required other than a check as part of the annual habitation service.

Ensuring the water supply is free of debris when filling the tank will reduce the likelihood of pump clog.

Winterising

To protect against damage as a result of freezing, drain the entire water system.

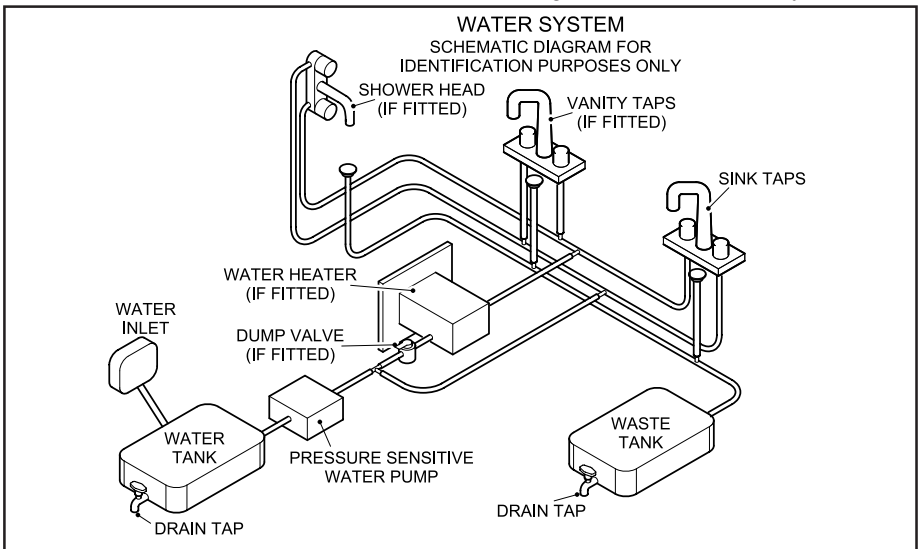



FRESHWATER FILLER

The Whale Watermaster system is used on your vehicle to make easier the connection of an outside water supply to the water system.

Operation

Priming:

1. Open one cold tap (e.g. kitchen sink).
2. Place pump into water container.
3. Insert plug into wall socket.
4. Whale socket: Locate plug tab into lid slot and close lid to lock in position in the socket.

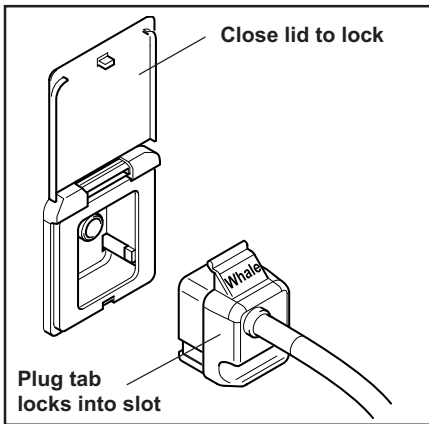

5. Adjust dust cover over opening in container (please note dust cover should not be secured to water container as air must be allowed to enter container to replace water being pumped out).
6. Switch on 12 volt supply at main panel isolator switch.
7. Water will flow from the open tap expelling any trapped air in a few seconds.
8. Turn off tap, the system is now ready for use.

When removing plug

1. Switch off 12 volt supply at main panel isolator switch.
2. Whale socket: Lift socket lid to release plug.
3. Pull out plug from socket using hand grip.
4. Shut lid.

The submersible pump can be run for quite long periods when in water, but it is recommended that running periods should be restricted to a maximum of 15 minutes. Do not run the pump without water. Do not use the pump in water temperatures above 40°C (100°F). It is best to stand the pump vertically.

Maintenance

The pump is fitted with a strainer which should be inspected and cleaned at frequent intervals. The pump is a completely sealed unit, no maintenance is required.

Helpful Hints:

Before switching on, place the pump in water and shake for a few seconds in a horizontal or inverted position to release trapped air. This will ensure successful priming and should be repeated after refilling the water tank. The plug for the Whale socket has a groove under the handgrip for clipping the water hose into when refilling the water container.

Fault Finding

1. If the pump will not run:
Check contacts in plug and socket are clean and making contact. Check wiring connections.
2. If the pump cycles on/off with tap closed:
Check for air or water leaks in taps and piping. Re-adjust pressure switch.
3. If pump motor runs steadily and will not stop:
Check that there is water in the container. Battery voltage may be too low (at or below 10.5 volts). Adjust pressure switch and/or recharge battery. Check all connections in pipe-work. The Whale Tiptoe Pump can be fitted in-line with the submersible pump and used as a manual back-up.

Notes

- * The socket lid must be used to lock the plug securely into the socket.
- On the back of the filler socket, on the inside of the vehicle, is an adjusting screw for the pump solenoid. This is set by the manufacturer and under no circumstances should it be tampered with by the owner.



WATER PRESSURE SWITCH

Adjustment

Your pressure switch is factory set and should not normally require adjustment. In the event that your pump doesn't switch off when you close the taps, or it pulses on and off when the taps are fully open, follow these guidelines to readjust the setting.

Pressure switch adjustment may be required usually because the power supply voltage has varied from the previous setting. Possible causes are: a. Battery drainage through normal use b. Higher voltage supply when battery charger operating

Pressure Switch Setting

1. Ensure the system, including the heater is full of water and all taps are closed. Refer to your user manual. Be sure to set the switch at low battery condition.
2. If present, remove the pressure switch locknut in an anti-clockwise direction, then tighten the adjusting screw clockwise until the pump comes on.
3. Open any tap until you have a smooth flow of water, then close the tap. You should hear the pump running and the pump running light if fitted will be on.
4. Return to the pressure switch and turn the screw slowly anti-clockwise until the pump has stopped. Turn the screw a further half turn (180 degrees) anti-clockwise.
5. Check for correct operation by opening and closing all taps individually. The pump should turn on when the cold tap is opened and switch off immediately when the cold tap is closed. NB At low flows there may be some pulsation.
6. The hot side may take about 10 seconds to react (both on and off) due to cushioning from the water heater.
7. Carefully replace the lockout until it is tight keeping the adjustment screw in position.

Remember: You may also have to adjust the pressure switch to cope with changes in voltage from either battery or mains. Do so using the above instructions.

If setting of pressure switch is still not correct you may experience:

Pump running continuously, even with tap closed. If undiscovered, could result in pump failure and flat battery. Most likely causes are that present voltage is significantly lower when last adjusted, or water container is empty.

CURE: Re-adjust switch or refill container

Pump does not run at all. If not due to blown fuse or faulty connections, then most likely cause is excessive continuous running (see 'a' above)

CURE: Replace pump and readjust switch

Pump runs intermittently ON, OFF, ON, OFF etc. Seen as pulsing flow from tap, or as inability to set constant water temperature, water goes hot, cold, hot, cold instead of constant warm. Most likely cause is that present voltage is significantly higher than when last adjusted.

CURE: Readjust pressure switch, if problem persists add a Whale Surge Damper.

Pump runs very noisily but does not pump water. Likely to occur after water container has been refilled. Pump is air-locked and is fighting to get air out and water in.

CURE: Unplug from the socket, allowing pump to flood, and reconnect by plugging in again. The correct sequence when refilling the container is to unplug, put pump into container, then reconnect.

Pump continues to run for up to 30 seconds after tap is turned off. This is not a problem. This is a characteristic of pressure switch systems caused by the dampening effect of the hot water heater or surge damper on the cold side.

THREE GOLDEN RULES:

1. NEVER allow the pump to run dry.
2. NEVER allow the pump to run continuously for more than 15 minutes.
3. The pump assembly MUST be unplugged BEFORE putting the pump back into the refilled water container.



GAS

GENERAL INFORMATION

The gas appliances in this vehicle are powered by Liquefied Petroleum Gas (LPG) which is stored, under pressure, in a tank located under the floor in the centre of the vehicle. This tank is refilled, when required, at a re-fuelling station using a nozzle and hose in a similar way to refilling the engine fuel tank.

The Regulator

Your motorhome is equipped with a Truma gas regulator, which has a working pressure of 30 mbar, and is suitable for use with all commercially available brands of LPG. **Do not use appliances with a different working pressure.**

A Truma MonoControl CS unit is fitted adjacent to the regulator to automatically cut off the gas supply in the event of an accident. This assembly is fitted under the vehicle near the bulk tank installation. In the case of an accident with a deceleration of between 3 and 4g acting directly on the triggering element (equivalent to a collision speed of approximately 10-15 mph with a fixed obstruction), the integrated crash sensor will cut off the flow of gas. The gas supply can be restored by pressing the green button on the MonoControl inwards and holding for

approximately 10 seconds. It may be necessary to press with reasonable force, using a pen or pencil.

Availability

LPG is becoming more widely available as more vehicle engines are converted to run on it. Many garages now have an LPG pump and other outlets are available in more rural areas, often near farming communities for instance. Look for signs advertising 'Autogas'.

If you have internet access, search for 'LPG filling stations' and there are many sites where input of your postcode will locate the nearest filling station to your location.

There are many companies producing LPG but all brands are suitable for use in your vehicle.

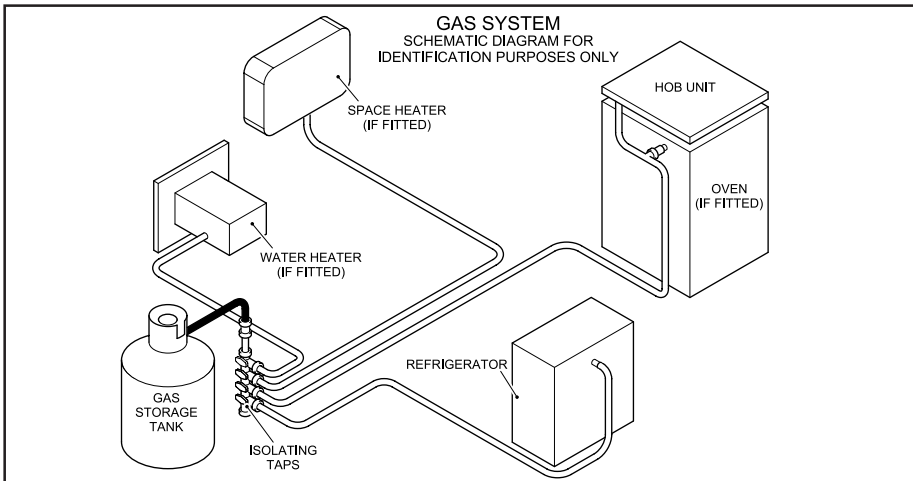

LPG Re-fuelling

LPG re-fuelling is simple and efficient, carried out in much the same way as petrol and diesel with a hose and nozzle designed to lock onto the filling connector on the vehicle. The refuelling point is located behind a black plastic cover on the offside of the vehicle behind the driver's door.

Once the connection is made, the customer simply presses and holds down a button on the dispenser until they have put the required amount of fuel into the vehicle or until the tank is full.

LPG tanks are fitted with a valve that stops the flow once the tank has reached its maximum safe filling level. Once the meter stops the customer simply disconnects the nozzle and returns it to the dispenser.

Note: Although the nominal capacity of the tank is 25 litres, a float valve automatically cuts off at 80% full to allow space for the gas vapour above the liquid. Therefore, the maximum amount of LPG which can be put into the tank is 20 litres.

There is a gauge for the LPG tank, fitted at the right hand side of the dashboard, which uses LED lights to indicate the fuel level.

Safety Note

- When pulling up to the Autogas dispenser ensure the vehicle is parked with the filling connector located nearest to the dispensing pump.
- Apply the handbrake and switch off the engine. If the Combi space heater is running it will turn off automatically. It will need to be re-started at the control panel after the engine has been re-started.
- No smoking, naked flames or mobile phones are allowed on the Service Station forecourt.
- If the re-fuelling process will take longer than 15 minutes (ie with the ignition off) then turn the refrigerator off at its main switch in order to prevent it from switching automatically to the alternative energy source of gas and producing an ignition spark.
- The use of an adaptor is not recommended.

Note: For European touring, adapters for use with the UK bayonet filling connector may be used temporarily.

- Refilling of portable LPG cylinders is not allowed.
- All dispensing nozzles should be fitted with a nozzle shield. Please report to staff if missing.

Filling Nozzles

When connecting the nozzle to the filler valve on your vehicle always check that the locking pins are aligned.

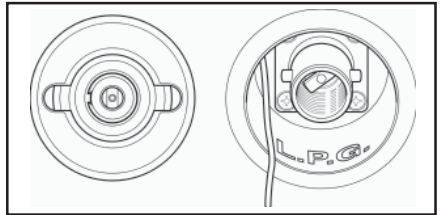

There are two main types of filling nozzles used in the UK - 'Gas Guard' and 'De Visser'. Gas Guard uses a rotating barrel to lock on to the filler valve whereas De Visser uses a lever.

1 - Gas Guard nozzle filling instructions

Ensure Gas Guard nozzles are fitted with protective nozzle shields. Report to site staff if missing. (Nozzle shields have been removed from picture for clarity).

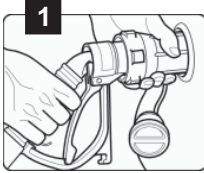

Connecting

(1) Push nozzle over the lugs on the filler valve and turn barrel a quarter turn clockwise to lock. Do not squeeze lever before nozzle is connected.

Caution: From this moment onwards ensure hands are away from the nozzle barrel.

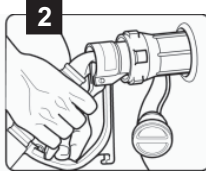

(2) Pull back lever and latch into place. Ensure lever is latched securely. Follow instructions on dispenser to commence dispensing.

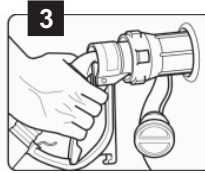

Disconnect

(3) Ensure hands are away from the nozzle barrel.

Caution: When dispensing has ended, squeeze back lever and release latch. Release lever fully. A small release of gas will occur as you release the lever. This is normal! Do not place hands on barrel until after the gas has been released.

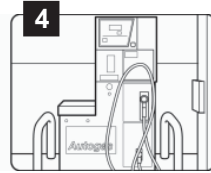

(4) Turn barrel anti clockwise a quarter turn to release nozzle from vehicle. Replace nozzle in holder on dispenser.

1 - De Visser nozzle filling instructions

Ensure De Visser nozzles are fitted with protective nozzle shields. Report to site staff if missing. (Nozzle shields have been removed from picture for clarity).

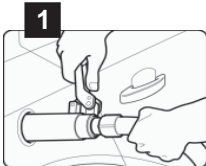

Connecting

(1) Hold the hose behind the nozzle and the guard, keeping lever pushed forward with the handle at 12 o'clock position. Locate the nozzle over the lugs on the filler valve and turn the lever a quarter turn clockwise to lock.

Caution: From this moment onwards ensure hands are away from the nozzle barrel.

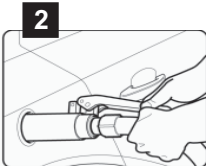

(2) Pull back lever towards hose and latch into place. Ensure lever is latched securely. Follow instructions on dispenser to commence dispensing.

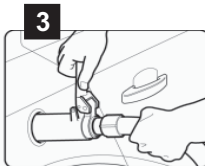

Disconnect

(3) Ensure hands are away from the nozzle barrel.

Hold hose behind guard and release lever by pushing forward. A small release of gas will occur as you release the lever. This is normal!

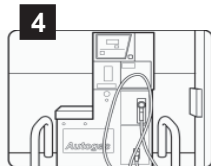

(4) Turn lever anti clockwise a quarter turn to release nozzle from vehicle. Replace nozzle in holder on dispenser.

GAS SAFETY ADVICE

Facts about LPG

- LPG is not poisonous.
- LPG has been given a smell by manufacturers in order to identify leaks.
- Bi-products of combustion are harmless.
- There is danger if all air and oxygen are excluded, therefore ventilation holes must be kept clear at all times.

PRECAUTIONS

- a) Never look for a leak with a match. Always use a soap solution or its equivalent when testing connections. Do not operate any electrical apparatus whatsoever, especially light switches. If the leak is not obvious, the vehicle should be evacuated and qualified personnel consulted.
- b) Avoid naked lights when re-fuelling.
- c) LPG is more dense than air. Consequently any vapour may flow along the ground and into drains, sinking to the lowest level of the surroundings and be ignited at a considerable distance from the source of leakage. In still air the vapour will disperse slowly.

MAINTENANCE

To ensure that the LPG tank installation remains safe the following maintenance must be carried out by a competent person.

Annually:

- Visual examination of the LPG tank, filling point, valves, regulators and fittings for:
- Dents and gouges
- Corrosion, particularly under any mounting strap or bracket
- Condition of the hoses, mounting straps, brackets and fixing to the vehicle
- Damage to valves and fittings, in particular the filling connection and cap
- Correct operation of valves, regulator, over pressure shut-off valve and fittings

All defects shall be rectified by a competent person

At periods not exceeding 10 years

This period is based on the date of manufacture (or previous test) marked on the tank. The tank shall be:

- Removed from the vehicle
- Stripped and subject to a thorough examination
- Re-painted
- The valves replaced
- Hoses replaced
- Tested after assembly and re-certified by a competent person

Alternatively, replacing the LPG tank will satisfy these requirements.

Repair

Note the following important safety warnings:

- Vehicles undergoing repairs involving welding or the application of heat, to any part within 1m of the LPG fuel tank, should have the fuel lines emptied and the tank removed or shielded from the source of heat.
- Vehicles with LPG tanks should not be put through a low bake repainting oven or similar heating process unless the temperature is controlled to less than 40°C.

CHANNEL TUNNEL

Eurotunnel now allows motorhomes fitted with LPG tanks for habitation purposes (although not for propulsion) to use the shuttle service. Their regulations say that the maximum capacity of the tank must not exceed 93 litres, it must be fitted with a capacity gauge and not filled to more than 80% of it's capacity. All these criteria apply to our standard installation.

Note: All the red gas isolation taps must be in the 'closed' position before boarding and remain closed for the duration of the journey.

IN AN EMERGENCY

In an emergency the gas supply to any of the appliances can be cut-off by closing the red isolation taps located inside the vehicle, see Location of Key Facilities chart.

If it is necessary to cut off the gas supply at the tank underneath the vehicle, then remove

the valve housing cover by unscrewing the black plastic knob. Then turn the large brass knob clockwise to close the outlet valve.

Note: When replacing the housing cover ensure that the rubber seal around the edge is located correctly in the groove.

ACCESS TO LPG TANK GAS OUTLET VALVE

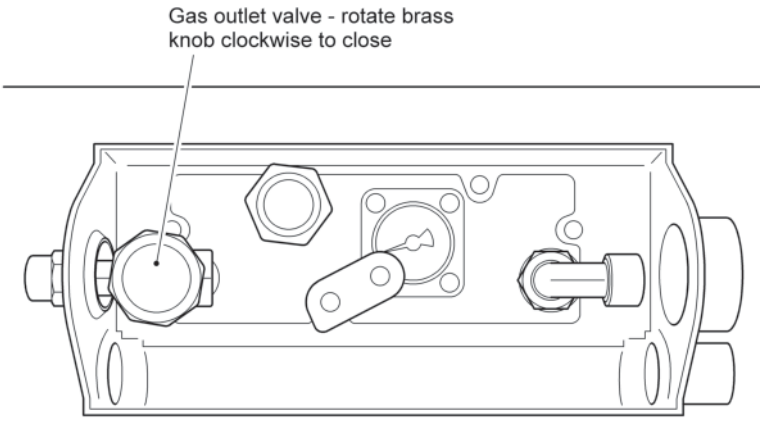
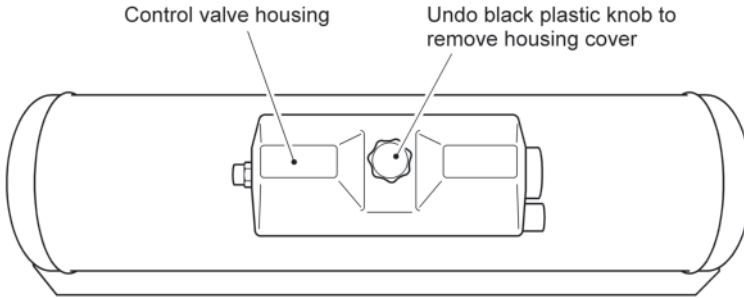

VENTILATION

General

Fixed ventilation is a statutory requirement in all motorhomes. These ventilation apertures are positioned at both high and low level and for your safety should not be obstructed, even partially.

Low Level Ventilation

Under each appliance is a fixed ventilation aperture, of a size commensurate with the rating of the appliance itself. It is either gauze covered or incorporates a fixed plastic vent. This should be checked regularly to see that it has not become blocked.

High Level Ventilation

High level ventilation is provided by the roof vents. The ventilation provided has been carefully calculated and relates to the rating of the appliances in the vehicle. Roof vents must not be covered with anything that may limit or affect the ventilation they provide.

Maintenance

Under no circumstances should any fixed ventilation aperture be blocked, covered, either partially or fully, or be modified in any manner whatsoever. They should be checked at least annually for damage or blockage.

Screens and/or grilles should be kept clean and free from dust. See diagram of upper/lower ventilation.

All ventilation complies with BS EN 721 and vents should not be obstructed in any manner as this could lead to insufficient fresh air. In this case the confined atmosphere becomes depleted of oxygen which leads to the formation of the highly poisonous gas 'carbon monoxide'. Carbon Monoxide is odourless, colourless and tasteless and will rapidly cause unconsciousness and death with little or no warning prior to collapse. **THERE IS NO DANGER WHEN ADEQUATE VENTILATION IS PROVIDED.**

When you are cooking, it is essential to provide additional ventilation such as opening windows near grill, cooker or oven.

Roof-mounted Flue installations

All flue installations should be inspected once a year throughout their length for corrosion. Flues should be replaced if any sign of perforation is found. Ensure that the replacement is of an approved type.

WARNING: Never allow modification of LPG systems and appliances except by qualified persons.

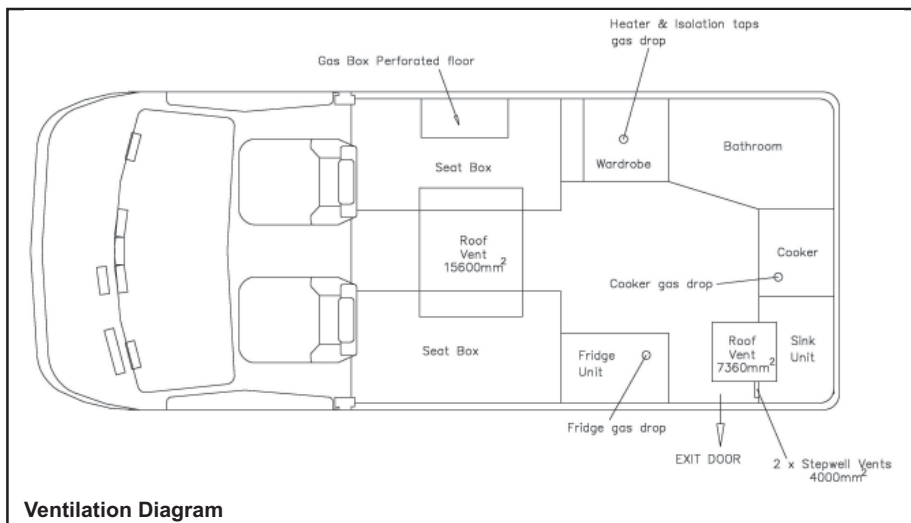

Ventilation Diagram



Connection

Ensure that the gas regulator is correctly connected to the gas cylinder in gas bottle compartment and that the hose is tight. Before turning on the gas supply, ensure that all gas operated equipment in the motorhome is turned off.

All gas equipment is supplied through a central Gas Manifold System which has individual isolation taps for each appliance denoted by a symbol (see below).

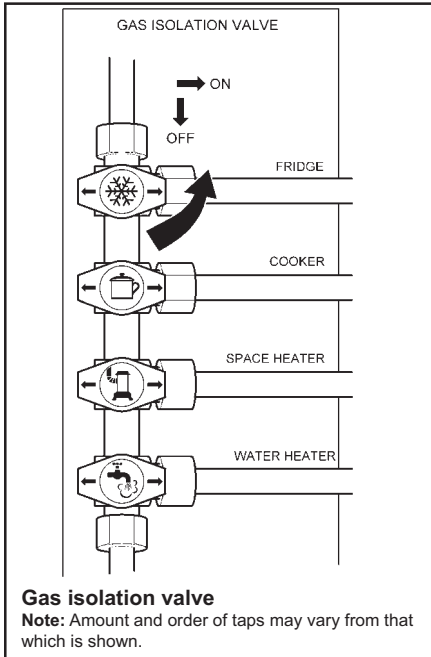

WARNINGS:

- 1 **Interior outlet sockets must only be used with original appliances supplied by manufacturer.**
- 2 **No appliance must be used outside when connected to an internal socket.**
- 3 **No additional appliance must be used inside the motorhome.**

Never use portable cooking or heating equipment other than electric heaters, that are not of the radiant type as they are a fire and asphyxiation hazard.

Safe Usage

To avoid accidents, the following fundamental advice should be carefully read before using gas appliances or changing gas cylinders.

- Always read and follow the use and maintenance instructions provided by the manufacturers of gas equipment. Should any soot accumulate on pans, fire radiants, etc., or any smell be produced, consult a competent installer on the correct maintenance and adjustment of burners.
- Never check for gas leaks with a naked flame.
- Always turn off the gas cylinder valve(s) or inlet to the motorhome or other dwelling when gas appliances are not in use.
- Never use gas appliances without adequate ventilation. All gas appliances require a plentiful supply of fresh air for correct operation. Fixed ventilators or air inlets should not be stopped up. Where practicable, turn off all appliances before retiring to bed, preferably at the cylinder or inlet to the motorhome or other dwelling.
- Unless the appliance incorporates automatic ignition, when lighting an appliance always make sure you apply a lighted match or taper to the burner before turning on the gas.
- If any appliance is disconnected for repair, maintenance, etc., ensure that the gas line is capped off.
- If taps are stiff to operate or appear to be a source of leakage, call in a competent installer to rectify. LPG taps require a special grease.
- Always seek advice when in doubt.

Input Ratings

Input rating for the gas appliances are as follows:

Refrigerator	0.1kW
Heater	2.4kW
Grill	1.5kW
Water heater	1.5kW
Oven	1.5kW
Hob burners (x3)	1.5kW (each)

ELECTRICITY

As with electricity in the home, care must be exercised when handling mains electricity.

Your attention is drawn to the following notice as laid down by the Institute of Electrical Engineers.

INSTRUCTIONS FOR ELECTRICITY SUPPLY

On arrival at caravan site

The motorhome mains inlet flexible supply cable and its limits are shown on page 7-12.

1. Before connecting the motorhome installation to the mains supply, check that:
 - (a) the mains supply is suitable for your installation and appliances, i.e. whether it is a.c. or d.c. and whether it is at the correct voltage and frequency,
 - (b) your installation will be properly earthed. Never accept a supply from a socket outlet or plug having only two pins, or from a lighting outlet, and
 - (c) any residual current device (earth leakage circuit breaker) in the mains supply to the motorhome has been tested within the last month.
 - (d) Ensure that the RCD and the main switch on the electrical control box are OFF until after the mains cable has been connected.

In case of doubt, consult the site owner or his agent.

2. **MAKE SURE THAT THE SWITCH AT THE SITE SUPPLY POINT IS OFF.**
3. Lift the cover of the electricity inlet provided on the motorhome, and insert the connector of the supply flexible cable.
4. Remove any cover from the socket outlet provided at the site supply point, and connect the plug at the other end of the supply flexible cable to this. Switch on the main switch at the site supply point.

Note: Use mains cable fully uncoiled and protect from traffic.

Caution: Be aware that the 12V appliances, except the refrigerator, will not operate whilst

the ignition is switched on and the vehicle engine running. The master switch on the electrical control panel controls the 12 volt supply.

IT IS IMPORTANT THAT THE MAIN SWITCH AT THE SITE SUPPLY POINT SHOULD BE SWITCHED OFF, THE SUPPLY FLEXIBLE CABLE DISCONNECTED, AND ANY COVER REPLACED ON THE SOCKET OUTLET AT THE SITE SUPPLY POINT BEFORE DISCONNECTING THE FLEXIBLE CABLE FROM THE MOTORHOME. IT IS DANGEROUS TO LEAVE THE SUPPLY SOCKET OR SUPPLY FLEXIBLE CABLE LIVE.

Note: Please check appliance manufacturers handbook to see if suitable for use with generator or charger.

A generator may only be connected via the mains socket. If using a generator you also need to comply with the requirements/instructions supplied with the generator.

Because motorhomes are sometimes left unused for long periods in the open, it is strongly advised that the mains installation is inspected periodically to ensure that it is safe to use. The IEE Wiring Regulations recommend that mains installations in motorhomes are re-inspected every 3 years by a qualified person (see list) who should sign and issue a periodic inspection report. (The manufacturer recommends annual inspections).

Suitably qualified persons acceptable to the NCC to sign and issue inspection and completion certificates are:

- an approved contractor of the National Inspection Council for Electrical Installation Contracting* or
- a member of the Electrical Contractors' Association
- a member of the Electrical Contractors' Association of Scotland
- a qualified person acting on behalf of the above (in which event it should be stated for whom he is acting).



*The names and addresses of Approved Contractors in any locality (there are over 10,500 in the UK) can be obtained from:

NICEIC
Warwick House
Houghton Hall Park
Houghton Regis
Dunstable LU5 5ZX
Telephone: 0870 013 0382
Email: enquiries@niceic.com

The names and addresses of members of the Electrical Contractors' Associations can be obtained direct from:

ECA
Esca House
Palace Court
London W2 4HY
Telephone: 020 7313 4800

WARNING: Current consumption in the motorhome must not exceed 16 amps or the pitch permitted maximum if this is less than 16 amps.

It is dangerous to attempt modifications and additions yourself. Never allow modification of electrical systems and appliances except by qualified persons. Lampholder-plugs (bayonet-cap adaptors) should not in any circumstances be used.

CAUTION: Electrical heaters have the potential to draw 8 amps at 2kW. It is, therefore, advisable to check the supply rating before switching on two loads (items) greater than the supply as this may cause an overload and the circuit breaker to trip.

OVERSEAS CONNECTION

Note: Connection to a mains voltage supply OVERSEAS requires particular attention.

Care must be taken when connecting supplies abroad since the supplies can be of REVERSE POLARITY.

The significance of REVERSE POLARITY is that when equipment is switched off it may not be electrically isolated.

The only certain way of making equipment safe is to unplug it.

If it can be achieved, it is preferable to connect live to live, and neutral to neutral to maintain full electrical protection.

WARNING: It is essential that connections are made exactly as shown. If terminal markings are not in accordance with the diagram they must be ignored. If in doubt consult a qualified electrician.

The legal length of the mains inlet cable is 25 ± 2 metres. When in use it must be fully uncoiled and protected from traffic.

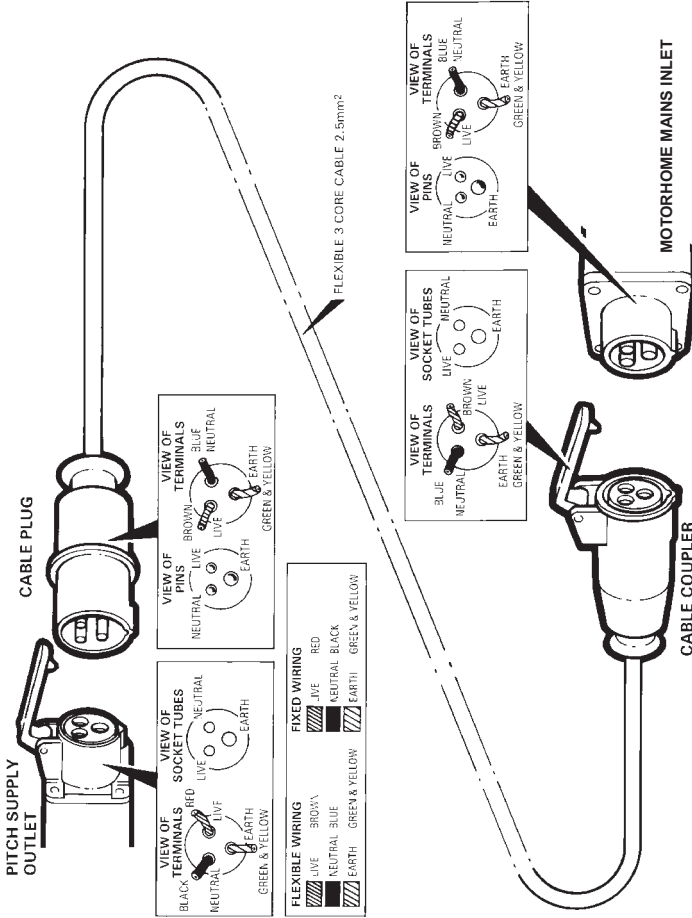

WIRING OF CONNECTING CABLE AND MOTORHOME MAINS INLET

EC500 POWER CONTROL SYSTEM

1 INTRODUCTION

This section of the handbook will guide you through the operation of the electrical system.

Further technical details are contained in sections 3 to 6 or in the supporting technical manual available from www.sargentltd.co.uk

For the safe operation of all electrical equipment within your Leisure Vehicle it is important that you read and fully understand these instructions. If you are unsure of any point please contact your dealer / distributor for advice before use.

The system has a number of key components that you will need to be familiar with before attempting to use the system, these are:

- The EC500 series Power Supply Unit (PSU) -a combined mains consumer unit and 12V controller.
- The EC480 series Control Panel (CP) -a remotely located user control panel used to turn circuits on and off and to display battery and water tank information.
- The PX-300 Battery Charger / Power Supply – A separate, air cooled 300 Watt multi-stage power converter unit that charges the batteries and provides 12V DC power.
- The EM45 Interface Unit - This small unit is located at floor level behind the drivers' seat. The unit houses fuses for the fridge, vehicle battery, radio and other systems. It also provides connections for the optional tow bar harness.

2 USING THE SYSTEM

2.1 EC500 Power Supply Unit - Component Layout

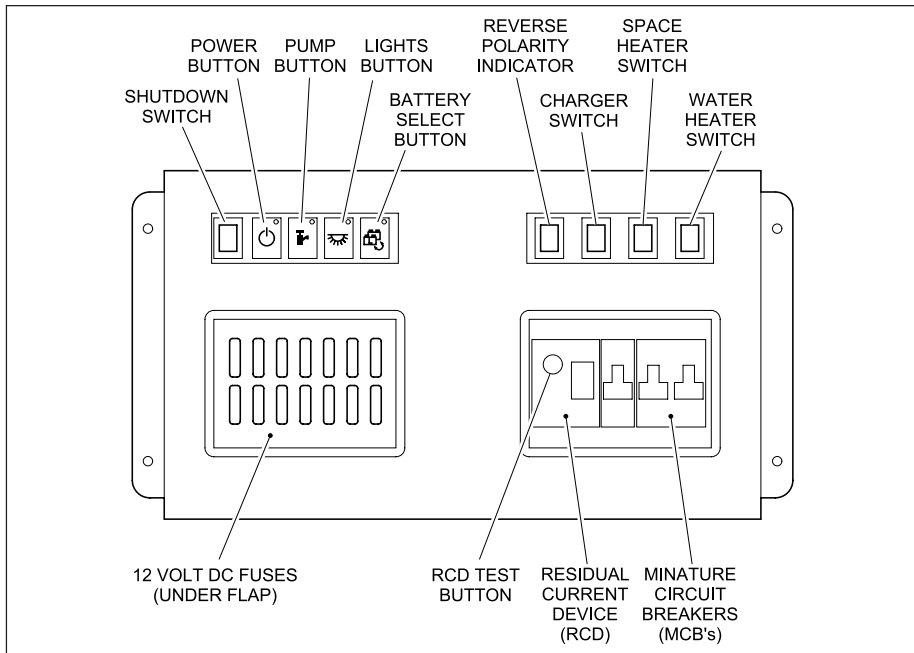

2.2 Activating the System

The EC500 system has a shutdown feature that should be used when the vehicle is in storage or is not being used for long periods of time. This allows the leisure electronics to be turned off when not required to save battery power. When in the off state the alarm and tracking system supplies are still active, most other supplies are turned off.

Before using the system please ensure the system shutdown switch is in the on position (button in).

2.3 Connecting to the Mains 230V supply and Safety checks

For your safety it is IMPORTANT that you follow these connections instructions each time your Leisure Vehicle is connected to a mains supply. This section assumes that the system is complete and that a Leisure battery has been installed (see 3.5).

- A) Ensure suitability of the Mains Supply. Your Leisure Vehicle should only be connected to an approved supply that meets the requirements of BS7671 or relevant harmonised standards. In most cases the site warden will hold information regarding suitability of supply. If using a generator you also need to comply with the requirements / instructions supplied with the generator. Please note that some electronic generators may not be compatible with your leisure system. Further generator operational information is contained elsewhere in this manual.
- B) Switch the PSU internal Power Converter OFF. Locate the green 'Charger' power switch on the PSU and ensure the switch is in the off position (button out) before connection to the mains supply.
- C) Connect the Hook-up Lead. Firstly connect the supplied hook-up lead (orange cable with blue connectors) to the Leisure Vehicle and then connect to the mains supply.
- D) Check Residual Current Device operation. Locate the RCD within the PSU and ensure the RCD is switched on (lever in up position). Press the 'Test'

button and confirm that the RCD turns off (lever in down position). Switch the RCD back to the on position (lever in up position). If the test button failed to operate the RCD see section 3.14.

- E) Check Miniature Circuit Breakers. Locate the MCB's within the PSU (adjacent to the RCD) and ensure they are all in the on (up) position. If any MCB's fail to 'latch' in the on position see section 3.14.
- F) Turn the PSU ON. Locate the black 'Shutdown' button and ensure it is in the on position (press button to change, button in = on, button out = off). Locate the green 'Charger' switch on the PSU and turn to the on position (press button to change, button in = on, button out = off). The charger switch will illuminate when turned on.
- G) Check correct Polarity. Locate the 'Reverse polarity' indicator on the PSU and ensure that the indicator is NOT illuminated. If the indicator is illuminated see section 3.10.
- H) Check operation of equipment. It is now safe to operate the 12v and 230v equipment.







Note: The isolation switch labelled 'Water Heater Switch' on the front face of the control box is not functional on this model because the water and space heaters are combined in the Truma Combi.

This switch is used if the optional air conditioning is fitted, in which case it has an 'Air Con' label stuck over the original text.





2.4 EC480 Digital Control Panel (Colour graphic display)



2.5 Control Panel Operation

EC480	Button Description
	<p>Power Button. Press the power button to turn the leisure power on. Press the button again to turn the power off. The adjacent LED will illuminate when the power is on, and also the voltage of the selected battery will be displayed on the screen. This button is also present on the PSU unit, so this feature can also be operated from the PSU.</p>
	<p>Pump Button. With the power on, press the pump button to turn the water pump on. Press the button again to turn the pump off. The adjacent LED will illuminate when the pump is on, and also the level of the water tank will be displayed on the screen. This button is also present on the PSU unit, so this feature can also be operated from the PSU.</p>
	<p>Light Button. With the power on, press the light button to turn the main internal lighting on. Press the button again to turn the lights off. The adjacent LED will illuminate when the lights are on. The lights will be turned on and off automatically each time the power button is operated. This button is also present on the PSU unit, so this feature can also be operated from the PSU.</p>
	<p>Battery Select. By default, the leisure battery is selected as the power source if no mains supply is present, or as the battery to be charged when the mains supply is available. To change the selected battery, press the vehicle battery select button. The selected or 'Active' battery is shown on the screen, and on EC300 panels is also indicated by the adjacent LED (LED off = Leisure battery, LED on = vehicle battery).</p>
	<p>Awning Light Button. With the power on, press the awning light button to turn the awning light on or off. The adjacent LED will illuminate when the light is on.</p>
	<p>Frost Protect Button. When the frost protection option has been installed, with the power on, press the frost protect button to turn on the water tank heating system. The adjacent LED will illuminate to show that the tank heating system is on. WARNING: Read about the waste tank isolation switch in Water Tank Heaters part of Section 9.</p>



EC480	Button Description
	Ceiling Light Button. This switch turns the ceiling lights on and off.
	Scroll Up. Use this button to scroll through the various menu / screen items or to make setting adjustments
	Select. Use this button to select options/items or to cancel alarms/warnings. <u>Note:</u> The screen illumination/backlight will turn off after a period of time. Press the select button to reactive the illumination.
	Scroll Down. Use this button to scroll through the various manu/screen items or to make setting adjustments.



2.6 Operation while driving

The EC500 system is designed to shutdown parts of the system whilst the engine is running. This is to meet Electro Magnetic Compatibility (EMC) regulations and to ensure the safe operation of your motorhome.

Please ensure the system shutdown switch on the PSU is in the “on” (button in) position before driving (see 2.2). This will ensure the electronic system is active and will therefore be able to control the charging process, supply the refrigerator and monitor other system circuits.

When fitted, designated 12v sockets, en-route reading lights and en-route heating will remain operational while the engine is running.

If you hear a warning buzzer when the engine is started, please see the control panel display for details and also refer to section 3.11.

3 System Technical Information

The following section provides further technical information relating to the electrical system.

3.1 System Configuration

There are a number of dealer configurable features within the system. Your dealer will discuss these options with you and make the necessary adjustments as required. Should you wish to review the possible options / settings, further information can be sourced from www.sargentltd.co.uk

3.2 Residual Current Device & Miniature Circuit Breakers

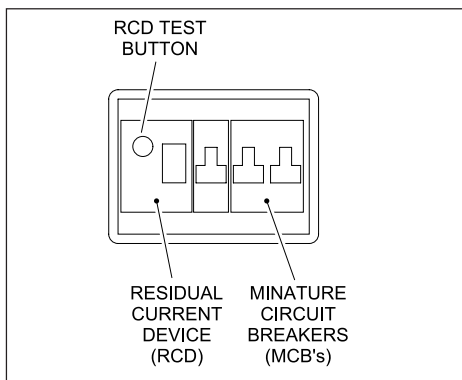

The Residual Current Device (RCD) is basically provided to protect the user from lethal electric shock. The RCD will turn off (trip) if the current flowing in the live conductor does not fully return down the neutral conductor, i.e. some current is passing through a person down to earth or through a faulty appliance.

To ensure the RCD is working correctly, the test button should be operated each time the vehicle is connected to the mains supply (see section 2.3)

The Miniature Circuit Breakers (MCB's) operate in a similar way to traditional fuses and are provided to protect the wiring installation

from overload or short circuit. If an overload occurs the MCB will switch off the supply. If this occurs you should investigate the cause of the fault before switching the MCB back on.

The following table shows the rating and circuit allocation for the three MCB's

MCB	Rating	Output Wire Colour	Description
1	10 Amps	White	230v Sockets
2	10 Amps	White (Yellow for heater)	Extra 230v Sockets / Space Heater
3	10 Amps	Black (Blue for water heater)	Fridge / Water Heater / 12v Charger (internally connected)

3.3 Battery Charger

The EC500 system incorporates an intelligent three-stage battery charger / power converter.

During stage 1 the battery voltage is increased gradually while the current is limited to start the charging process and protect the battery. At stage 2 the voltage rises to 14.4V to deliver the bulk charge to the battery. When the battery is charged, the voltage is decreased at stage 3 to 13.6V to deliver a float charge to maintain the battery in the fully charged state. The charger can be left switched on continuously as required.

The battery charger / power converter also provides power to the leisure equipment when the mains supply is connected. This module supplies DC to the leisure equipment up to a maximum of 25 Amps (300 Watts), therefore the available power is distributed between the leisure load and the battery, with the leisure load taking priority as per the following example:

Leisure load	Available power for battery charging
5A	20A
10A	15A
15A	10A
20A	5A

WARNING: Under heavy loads the charger case may become hot. ALWAYS ensure any ventilation slots have a clear flow of air. Do not place combustible materials against/adjacent to the charger.

3.4 Smart Charging

The EC500 system incorporates a smart charge feature, which monitors both leisure and vehicle batteries and automatically adjusts and directs the charger power (and solar power if a solar panel is installed) to maintain the leisure and vehicle batteries at an optimal level.

3.5 Leisure Battery

3.5.1 Type / Selection

For optimum performance and safety it is essential that only a proprietary brand LEISURE battery is used with a typical capacity of 75 to 120 Ah (Ampere / hours). A normal vehicle battery is NOT suitable. This battery should always be connected when the system is in use.

The PSU is configured to work with standard lead acid leisure batteries, and in most cases is also compatible with the latest range of Absorbed Glass Matt (AGM) batteries. Before fitting non-standard batteries please check that the charging profile described in 3.3 is suitable for the type of battery by referring to the battery documentation or battery manufacturer.

Some vehicle installations can cater for two leisure batteries connected in parallel. In these cases it is recommended that two identical batteries are used.

The battery feed is fitted with an inline fuse between the battery and the electrical harness, and is usually located immediately outside the battery compartment or within 500mm of the battery. The maximum rating of this fuse is 20A per battery. If a single battery is fitted to a motorhome, this fuse may be increased to 30A, however if two batteries are fitted each battery should be fused at a maximum of 20A.

3.5.2 Installation & Removal

Always disconnect the 230v mains supply and turn the PSU green charger switch to the off position (button out) before removing or installing the battery.



When connecting the battery, ensure that the correct polarity is observed (black is negative [-] and red is positive [+]) and that the terminals are securely fastened. Crocodile clips must not be used.

WARNING: Explosive gases may be present at the battery. Take care to prevent flames and sparks in the vicinity of the battery and do not smoke.

3.5.3 Operation / Servicing

Under normal circumstances it should not be necessary to remove the battery other than for routine inspection of the terminals and "topping up" of the battery fluid where applicable. Please see instructions supplied with the battery.

Note: Do not over discharge the battery. One of the most common causes of battery failure is when the battery is discharged below the recommended level of approximately 10v. Discharging a battery below this figure can cause permanent damage to one or more of the cells within the battery.

To prevent over discharge, the EC500 system incorporates a battery protect circuit that warns the users and then disconnects the batteries when they fall below set values.

If the power is turned on and the leisure battery level falls below 9V a warning beep will be heard and information will be shown on the screen. To cancel the warning, press the select button.

If the power is turned on and the vehicle battery level falls below 10.9V a warning beep will be heard and information will be shown on the screen. If no action is taken the system will switch over from the vehicle battery to the leisure battery. To cancel the warning, press the select button.

These warnings will not be repeated unless the power switch is turned off and on again. This is to ensure the warning does not become a nuisance.

Battery	Cut off	Action after cut off	Notes
Vehicle	10.9V	Battery selection is changed from Vehicle battery to Leisure battery. If the leisure battery is below 9V then a further warning will occur (see below).	This cut off level is designed to protect the vehicle battery from over discharge. The 10.9V level ensures there is sufficient power in the battery to run the vehicle electronics and start the vehicle. This cut off only applies to power drawn from the battery by the leisure equipment; it will not protect the battery if you leave vehicle circuits switched on, such as the road lights.
Leisure	9V	Power is turned off	This is an emergency cut off level to protect the battery from severe damage. You should not rely on this cut off level during normal operation, but manage your power consumption to a discharge level of 10V. This cut off only applies to power drawn from the battery by the leisure equipment that is controlled by the control panel power switch; it will not protect the battery from discharge by permanently connected equipment.



3.6 Solar Charge Management

The EC500 PSU incorporates a built-in solar charge management feature, which will control the input from a solar panel (when fitted, maximum rating 120W). Depending on the charge state of the batteries, the solar power will be directed to the required battery, and continuously monitored to ensure optimum operation. For this system to operate intelligently, the shutdown button should be left switched on. If the shutdown button is turned off then the solar panel will charge the leisure battery only.

3.7 Water System Operation

The control panel pump button operates the internal (onboard) water pump. This pump will draw water from the internal (onboard) water tank.

The water tanks (fresh & waste) incorporate a level warning feature to warn the user when the fresh water level drops below 25% or when the waste water level reaches 100%.

If the water pump power is turned on and the fresh water level drops to below 25% a warning beep will be heard information will be shown on the screen. To cancel the warning, press the select button.

If the water pump power is turned on and the waste water level rises to full (100%) a warning beep will be heard and information will be shown on the screen. To cancel the warning, press the select button.

These warnings will not be repeated unless the water pump power switch is turned off and on again. This is to ensure the warning does not become a nuisance.

3.8 Frost Protection

On vehicles fitted with water tank frost protection, the EC480 control panel frost protect switch can be used to turn the feature on or off.

3.9 Awning Light Operation

The awning light is control by the control panel awning / aux button. The awning light is also linked to the remote door locking. If the doors are locked or unlocked the light will illuminate for a short period of time. This is a dealer configurable item.

3.10 Electric Step Operation

On vehicles fitted with an electric step, this is operated by a button near the entry door. Press and release the button to move the step in or out. One press of the button will move the step out, a further press will move the step in again.

If the engine is started the step will move in automatically, after a short warning buzzer. If this operation fails due to an obstacle or mechanical failure a buzzer will sound continuously to warn that the step is still in the out position, and therefore requires your attention.

The electric step is also linked to the remote door locking. If the doors are unlocked the step will move out, if the doors are locked the step will move in. This is a dealer configurable item, and can be turned off if not required.



3.11 System Warnings

The system incorporates a number of warnings that are active at specific times. These are summarised below, and also covered by relevant sections of this manual.

Warning	When	Type
Fresh water level low	With pump turned on and fresh water level low (less than 25% full)	Message on screen and 1 minute audible beep
Waste water level full	With pump turned on and waste water level full (tank level 100%)	Message on screen and 1 minute audible beep
Vehicle battery voltage low	With control panel power on and vehicle battery selected (as active battery) and voltage level below 10.9V	Message on screen and 1 minute audible beep. If no action taken after 1 minute then the system will switch to the leisure battery
Leisure battery voltage low	With control panel power on and leisure battery selected (as active battery) and voltage level below 9V	Message on screen and 1 minute audible beep. If no action taken after 1 minute then the system will switch the power of to prevent over discharge of the battery
Alarm clock active	When alarm has been turned on and alarm time has been reached	Message on screen and 1 minute audible beep
Engine running	When the engine is started the system power will be turned off	Message on screen, on EC480 this will remain visible for 1 minute
Step still out	When the engine is started and the step has failed to retract automatically	Message on screen and rapid beeps from the control panel. The beeping will not stop until the fault is cleared.
Mains lead (hook-up cable) still connected / plugged in	When the engine is started and the mains cable is still plugged in and switched on	Message on screen and repeated beeps from the control panel. The beeping will not stop until the fault is cleared.

3.12 Event Timer Operation

The event timer is designed to allow the motorhome user to turn the 12v power on or off (in the same way as using the control panel power button) without being in the vehicle. This allows lights or other equipment to be turned on or off at a predetermined time.

Example - to turn on one interior light at 11.00pm for 1 hour

Ensure the clock is set to the correct time

EC480

Scroll to the System Time Setting screen

Follow the instructions in section 4 to set the ON time to 23:00 and the OFF time to 24:00

Set the Timer to ON

A stopwatch symbol will appear in the header area to indicate the timer is set

Turn all lights and 12v equipment off in the vehicle except the light that you want the event timer to automatically switch on

Exit the vehicle At 11:00pm (23:00) the control panel will switch the 12v power on and therefore any equipment that was left switched on will be turned on. The 12v power will be switched off at Midnight (24:00).

3.13 12 Volt DC Fuses

WARNING: When replacing fuses always replace a fuse with the correct value. NEVER replace with a higher value/rating as this could damage the wiring harness. If a replacement fuse ‘blows’ do not keep replacing the fuse as you could damage the wiring harness. Please investigate the fault and contact your dealer.

The following table shows the fuse allocation for the 15 fuses fitted to the PSU. Please note that fuses are dependant on PSU versions, so not all fuses may be present.

Fuse	Rating	Fuse Colour	Description
1	10 Amps	Red	Toilet
2	5 Amps	Tan	Ignitions
3	10 Amps	Red	Electric Step
4	10 Amps	Red	Water Pumps
5	10 Amps	Red	Permanent Supplies
6	20 Amps	Yellow	Leisure Battery
7	20 Amps	Yellow	Vehicle Battery
8	10 Amps	Red	Heater
9	10 Amps	Red	Power Circuits
10	10 Amps	Red	Lighting Circuit 1
11	10 Amps	Red	Lighting Circuit 2
12	10 Amps	Red	En-route Circuits
13	10 Amps	Red	Tank Heaters
14	10 Amps	Red	Future Supply
15	25 Amps	White	Charger (fitted internally to PSU)

The following table shows details of the fuse(s) located at the Leisure battery.

Fuse	Rating	Fuse Colour	Description
Battery 1	20 Amps	Yellow	Fuse remotely located near battery
Battery 2	20 Amps	Yellow	Fuse remotely located near battery 2 (where fitted)

The following table shows details of the fuse(s) located at the EM45 Interface Unit

Fuse	Rating	Fuse Colour	Description
1			Spare location
2	5 Amps	Tan	Marker Lights
3	20 Amps	Yellow	Tow Bar +
4	20 Amps	Yellow	Vehicle Battery
5			Spare location
6	20 Amps	Yellow	Fridge +
7	20 Amps	Yellow	Tow Bar D+
8	20 Amps	Yellow	Fridge D+



3.14 Common Fault Table

Fault	Possible Cause	Proposed Fix
No 230 volt output from PSU	Connecting lead between the site and Leisure Vehicle not connected	Check and connect lead as per 2.3C
	RCD switched off	Reset RCD as per 2.3D
	RCD not operating	Check supply polarity; if the RCD continues to fail contact your Dealer as there is probably an equipment or wiring fault
	MCB switched off	Reset MCB by switching OFF (down position) then back ON (up position), if the MCB continues to fail contact your Dealer as there is probably an equipment or wiring fault
	No or deficient supply from site	Contact site Warden for assistance
Reverse Polarity light is illuminated	Mains Supply reversed?	The reverse polarity light is designed to illuminate when the Live and Neutral supply has been reversed/crossed over. If the light illuminates there is a problem with the site supply or the cable connecting the supply to your vehicle. The light is designed to work on UK electrical supplies (where the neutral conductor is connected to earth at the sub station). If you are using your vehicle outside the UK this light may illuminate when no fault exists. In these cases consult the site warden for advice.
	Generator being used	'The Reverse Polarity warning light is on when using my Generator'. This is a normal side effect when using some types of generator. Instead of connecting the neutral conductor to earth, some generators centre tap the earth connection making both neutral and live conductors 110V above earth. This 110V difference causes the neon polarity indicator to illuminate. In most cases it is still safe to use the generator, but please consult the generator handbook for further information.
Control Panel problems	Control Panel has no display	Backlight/illumination may have switched off. Press the select button to reactivate the backlight.
		Check batteries and fuses, turn PSU shutdown switch and charger switch on and ensure mains supply is connected.
		Check control panel connecting lead at PSU and behind Control Panel
		Contact your Dealer
	12V power turns off	Battery protect feature has operated to protect the Vehicle battery and or the Leisure battery. See 3.5.3.
Engine has been started, all equipment has been disconnected to meet EMC requirements. See 2.7.		
Control Panel locked/erratic function	Observe control panel handling instructions. Control panel software may have crashed. Reboot control panel by turning off the PSU isolate switch. Wait 30 seconds then turn the switch back on.	
No 12 volt output from PSU	No 230V supply	Check all above
	Charger not switched on	Turn charger switch on, switch will illuminate
	Battery not connected and/or charged	Install charged battery as per 3.5

Continued next page

3.14 Common Fault Table (continued)

Fault	Possible Cause	Proposed Fix
No 12 volt output from PSU (continued)	Power button on control panel not switched to on	Turn power on at control panel
	Battery flat / Battery fuse	Recharge battery, check fuses, check charging voltage is present at battery
	Fuse blown	Check all fuses are intact and the correct value fuse is installed as per fuse table
	Equipment switched off / unplugged	Check equipment is switched on and connected to the 12V supply
	PSU overheated / auto shutdown operated	Reduce load on system. Allow PSU to cool down. PSU will automatically restart when cool
	Other fault	Contact your Dealer
Pump not working	Fuse blown	Replace fuse with correct value as per fuse table
	Pump turned off	Turn pump on by pressing the pump button at the control panel
	Setting incorrect	Both the internal and external pump feeds are controlled from the control panel. To alter the setting of the pump switch see your dealer. Ensure the setting matches your desired requirement.

3.15 Contact details

Sargent Electrical Services Limited, provide a technical help line during office hours. Please contact 01482 678981 if you require technical help. For out of hour support please refer to the tech support section of the Sargent web site www.sargentltd.co.uk

4 EC480 Control Panel

In addition to the information contained in section 2.5 (Control Panel Operation), the following section provides further detail information.

4.1 Backlight Operation

The screen backlight (illumination) is turned on and off automatically. When operating on battery power only the backlight time is 30 seconds. When operating on mains power the backlight time is increased to 2 minutes. Pressing the select button will reactivate the backlight.

If the large clock screen is selected (see 4.4.4 below) and the mains supply is on then the backlight will remain on continuously.

4.2 Header Area



The header area of the screen shows the following information;

At the left, the external temperature in centigrade

At the right, the internal temperature in centigrade

In the centre, the current time (24 hour clock)

In addition to the above, the following symbols (when shown) indicate;

 Mains supply connected and charger switched on

 Alarm clock set

 Event timer set

4.3 Footer Area

System TIME settings (Press < to edit)

The footer area of the screen shows details of the current information screen, and may also show additional information during specific operations.

4.4 Information Area

The main information area can display a variety of system information screens. These have been designed to present the information in a clear and concise form, while retaining technical detail for the more advanced users.

The selected screen can be changed by using the down or up buttons, and work on a continuous loop basis. The selected screen may be changed automatically by the system depending on the action being performed.

4.4.1 Splash Screen

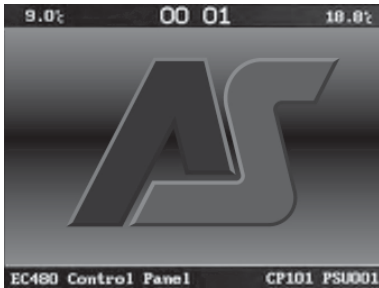

This screen shows the header and footer detail, along with the Auto-Sleepers logo.

4.4.2 System Levels Screen

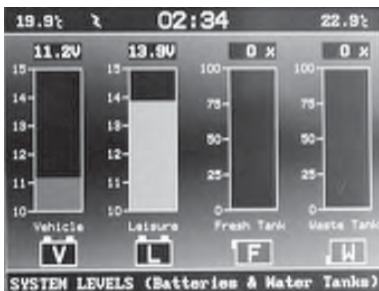

This screen shows, from left to right;

- [V] Vehicle battery voltage gauge. This gauge shows the voltage of the Vehicle battery in bar format, with the precise reading shown at the top of the bar. The actual bar changes colour according to the battery voltage. Less than 10.9V = red (Poor), 10.9V to 11.8V = yellow (Fair), 11.9V to 14.4V = green (Good).
- [L] Leisure battery voltage gauge. This gauge shows the voltage of the Leisure battery in bar

format, with the precise reading shown at the top of the bar. The actual bar changes colour according to the battery voltage. Less than 10.9V = red (Poor), 10.9V to 11.8V = yellow (Fair), 11.9V to 14.4V = green (Good).

- [F] Fresh water level gauge. This gauge shows the level of water in the Fresh water tank, with the reading also shown at the top of the bar. The actual bar changes colour according to the water level. 25% = red, 50% = yellow, 75% and above = green.
- [W] Waste water level gauge. This gauge shows the level of water in the Waste water tank, with the reading also shown at the top of the bar. The actual bar changes colour according to the water level. 25% = green, 50% = yellow, 75% and above = red.

4.4.3 Active Battery Screen

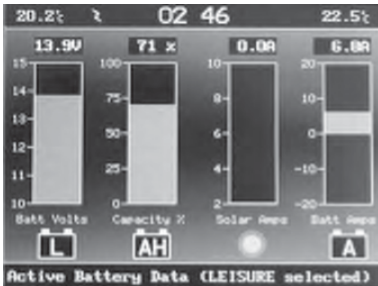

This screen is automatically selected when the battery select button is operated. The battery symbol bottom left will contain a 'L' if the leisure battery is selected and a 'V' if the vehicle battery is selected. From left to right;

- [L or V] Active battery voltage gauge. This gauge shows the voltage of the Active battery (the currently selected battery) in bar format, with the precise reading shown at the top of the bar. The actual bar changes colour according to the battery voltage. Less than 10.9V = red (Poor), 10.9V to 11.8V = yellow (Fair), 11.9V to 14.4V = green (Good).
- [AH] Leisure battery calculated capacity (percentage of Amp Hours). When the leisure battery is active (selected), this gauge will be shown. The gauge shows the predicted charge capacity of the battery. As the battery is charged this gauge will increase, as the battery is discharged (used) this gauge will reduce. This can provide a useful indication of usable battery power.
- [SUN] Solar panel ammeter. This gauge shows the current in Amps that is being provided by the solar panel (when fitted). The system will decide which battery to direct the solar power to. This is based on system logic (see section 3.6) and is indicated by a 'L' or 'V' in the centre of the sun logo.
- [A] Battery ammeter. This gauge shows the current in Amps going into or out of the Active (selected) battery. Positive current (+) indicates charging of the battery, and is indicated by a green bar. Negative current (-) indicated discharging of the battery, and is indicated by a yellow bar (low discharge) or red bar (high discharge).



4.4.4 Large Clock Screen



This screen shows a large display clock in 24 hour format.

4.4.5 Time and Timer Event Settings Screen



This screen is used to adjust any of the system times and to set the alarm clock or event timer. Press the select button to move through each setting. Press the up / down buttons to adjust the setting.

- Set Clock Time. First adjust the hour using the up / down buttons, then press select again to move to minutes and adjust with the up / down buttons.
- Set Alarm Time. Press the select button to move to alarm hour setting. Press the up / down buttons to adjust the setting, then press select again to move to minutes and adjust with the up / down buttons. Press select again to move to alarm on / off. Press the up / down buttons to adjust the setting. If the alarm is turned on, a bell symbol will be shown in the header area.
- Set Timer event on Time. Press the select button to move to timer hour setting. Press the up / down buttons to adjust the setting, then press select again to move to minutes and adjust with the up / down buttons.
- Set Timer event off Time. Press the select button to move to timer hour setting. Press the up / down buttons to adjust the setting, then press select again to move to minutes and adjust with the up / down buttons. Press select again to move to timer on / off. Press the up / down buttons to adjust the setting. If the timer is turned on, a stopwatch symbol will be shown in the header area.
- Press select again to exit the settings

4.4.6 System Warnings Screens



The system can display a number of warnings. The control panel will beep and display the appropriate message. Press the select button to cancel the warning.

See sections 3.4B and 3.8 for an explanation of typical system warnings.



5 EC300 Control Panel

Display	Description	Options / Notes
EC300 v2.20 12:00 23.90°C	Main Control Panel display showing model number (EC300), software version number, current time (12:00) and Internal temperature (23.9°C) in centigrade	The addition of a asterisk (*) in the top left of the display indicates that the alarm is set. The addition of a hash (#) in the top right of the display indicates that the event timer is set. The addition of the letters 'AC' in the centre of the display indicates that the AC Mains supply is switched on.
Leisure Battery 12.5v (Good)	Voltage reading and battery condition description for the on-board leisure battery See also 3.5.3	Less than 10.9 = (Poor) 10.9 to 11.8 = (Fair) 11.9 to 14.4 = (Good)
Vehicle Battery 13.3v (Good)	Voltage reading and battery condition description for the vehicle battery See also 3.5.3	Less than 10.9 = (Poor) 10.9 to 11.8 = (Fair) 11.9 to 14.4 = (Good)
Mains Supply ON	Indication of the 230V mains supply	ON = mains supply on OFF = mains supply off
Fresh Water 25% Full	Water level in the fresh water tank (5 measurement levels) If the water pump power switch is turned ON and the water level drops below 25% a warning beep will be heard and the LCD display will flash. To cancel the warning, press the select (◀) button. The warning will not be repeated unless the water pump power switch is turned off and on again. This is to ensure the warning does not become a nuisance.	0% <= 1/4 Full (Nearly empty) 25% >= 1/4 Full 50% >= 1/2 Full 75% >= 3/4 Full 100% = Full
Waste Water 0% Full	Water level in the waste water tank (5 measurement levels) If the water pump power switch is turned ON and the waste water level rises to 100% a warning beep will be heard and the LCD display will flash. To cancel the warning, press the select (◀) button. The warning will not be repeated unless the water pump power switch is turned off and on again. This is to ensure the warning does not become a nuisance.	0% <= 1/4 Full (Nearly empty) 25% >= 1/4 Full 50% >= 1/2 Full 75% >= 3/4 Full 100% = Full
External Temp 20.5°C	External temperature (in degrees centigrade) as measured by the external temperature probe	



5 EC300 Control Panel (continued)

<p>Tank Heaters ON</p>	<p>Shows the status of the Tank Heaters (on / off) (when fitted). Press the select button (◀) to switch between OFF and ON</p>	<p>The addition of a tank symbol (€) in the top centre of the main EC325 display indicates that the tank heater are on</p>
<p>Battery Current 5.4 Amps</p>	<p>Current (in Amps) being drawn from or charged into the selected battery. If a solar panel is fitted this display will include the current being provided by the solar panel</p>	<p>Negative figure (-) = current being drawn from the selected battery Positive figure = current being used to charge the selected battery</p>
<p>Water Tank Fill? (Start 1 Min)</p>	<p>Allows operation of the External pump for a period of one minute (for filling the internal tank from the external tank) Use the select button (◀) to START (or STOP)</p>	<p>Will have no effect if the External pump is already switched on (see above) Will not operate if the Internal (Fresh) water tank is showing 100% Full</p>
<p>Clock Set? 12:00</p>	<p>Access to set the internal clock Press the select button (◀) to select HOUR Use the up/down (▲▼) buttons to change Press the select button (◀) to select MINUTE Use the up/down (▲▼) buttons to change Press the select button (◀) to exit</p>	<p>Please note the clock uses a 24 hour cycle</p>
<p>Alarm Set? 12:00</p>	<p>Access to set the alarm clock Press the select button (◀) to select hour Use the up/down (▲▼) buttons to change Press the select button (◀) to select MINUTE Use the up/down (▲▼) buttons to change Press the select button (◀) to exit</p>	<p>Please note the alarm uses a 24 hour cycle</p>
<p>Alarm = OFF</p>	<p>Shows the alarm clock status (on/off) Press the select button(◀) to switch between OFF or ON</p>	<p>The addition of a asterisk (*0 in the top left of the main EC325 display indicates that the alarm is set</p>



5 EC300 Control Panel (continued)

Display	Description	Options / Notes
Set Event Timer?	<p>Access to set the event timer Press the select button (◀) to select HOUR ON Use the up/down (▲▼) buttons to change Press the select button (◀) to select MINUTE ON Use the up/down (▲▼) buttons to change Press the select button (◀) to select HOUR OFF Use the up/down (▲▼) buttons to change Press the select button (◀) to select MINUTE OFF Use the up/down (▲▼) buttons to change Press the select button (◀) to exit</p>	<p>Please note the event timer uses a 24 hour cycle The event timer is used to switch the control panel power on and off in the absence of the user/ occupier. See section 3.12 for further details</p>
Event Timer = Off 12:00 till 12:00	<p>Shows the event timer status (OFF/ON) and the current On and Off times Press the select button (◀) to switch</p>	<p>The addition of a hash (#) in the top right of the main EC300 display indicates that the event timer is set</p>
Vehicle Battery Dangerously Low	<p>This WARNING display indicates that the Vehicle battery voltage is low (10.9 volts or less). The panel will beep for one minute and then switch over to the Leisure Battery to prevent draining the Vehicle battery.</p>	<p>You can switch over to the Leisure battery immediately (and cancel the beep) by using the battery selector switch</p>
Leisure Battery Dangerously Low	<p>This WARNING display indicates that the Leisure battery voltage is low (6 volts or less). The panel will beep for one minute and then switch the power off to prevent damage to the leisure battery.</p>	<p>See section 3.11 for further details</p>
System disabled Engine started	<p>This WARNING display indicates that the system has been disabled because the vehicle engine is running</p>	<p>EMC (Electro Magnetic Compatability) directive 89/336/EEC requires that electrical accessories within the vehicle are disconnected while the vehicle is in motion</p>



6 TECHNICAL DATA & APPROVALS

6.1 Outline specification -EC500PSU & EC300, EC480 Control Panel

INPUT 230V	230 Volts / 0 to 16 Amps	+ / - 10%
OUTPUT 230V	RCD protected, 3 x MCB outputs fo 10A Separate switched channels for water heater, space heater and charger	
INPUT 12V	2 x 20A battery inputs via 2 x 4 way connectors	
SOLAR INPUT	1 x Dedicated solar panel input (20 to 100W panel) via a 4 way connector	
OUTPUT 12V	25A total output via multiple switched channels protected by 14 fused outputs	
CHARGER	Input 220-240 Volts AC +/- 10%, Frequency 50 Hz +/- 6%, Current 3A max. DC Output 13.6 to 14.4 Volts nominal, Current 25 Amps max (300 Watts) Overall size (HxWxD) 50 x 250 x 135mm	Fixing centres 128*128mm 1.2kg
Signal INPUT	4 x Fresh water level, 4 x Waste water level, 1 x Engine running, plus multiple vehicle connections	Fresh water negative sensed Waste water negative sensed
Data IN / OUT	CANBUS Data communication and power to Control Panel via 6 way connector	
IP rating	IP31	
Operating temperature	Ambient 0 to 35° Centigrade PSU case temperature with full load 65°C Max	Automatic shutdown and restart if overheated/overloaded
EC500PSU	Overall size (HxWxD) 315 x 195 x 150mm Clearances 75mm above, 50mm left and right	Weight 2.9kg
EC300, EC480 Control Panel	Overall size (HxWxD) 80 x 194 x 25mm Cut-out size (HxW) 60 x 165mm	Fixing centres 178mm Weight 140g



12V/230V WIRING DIAGRAM

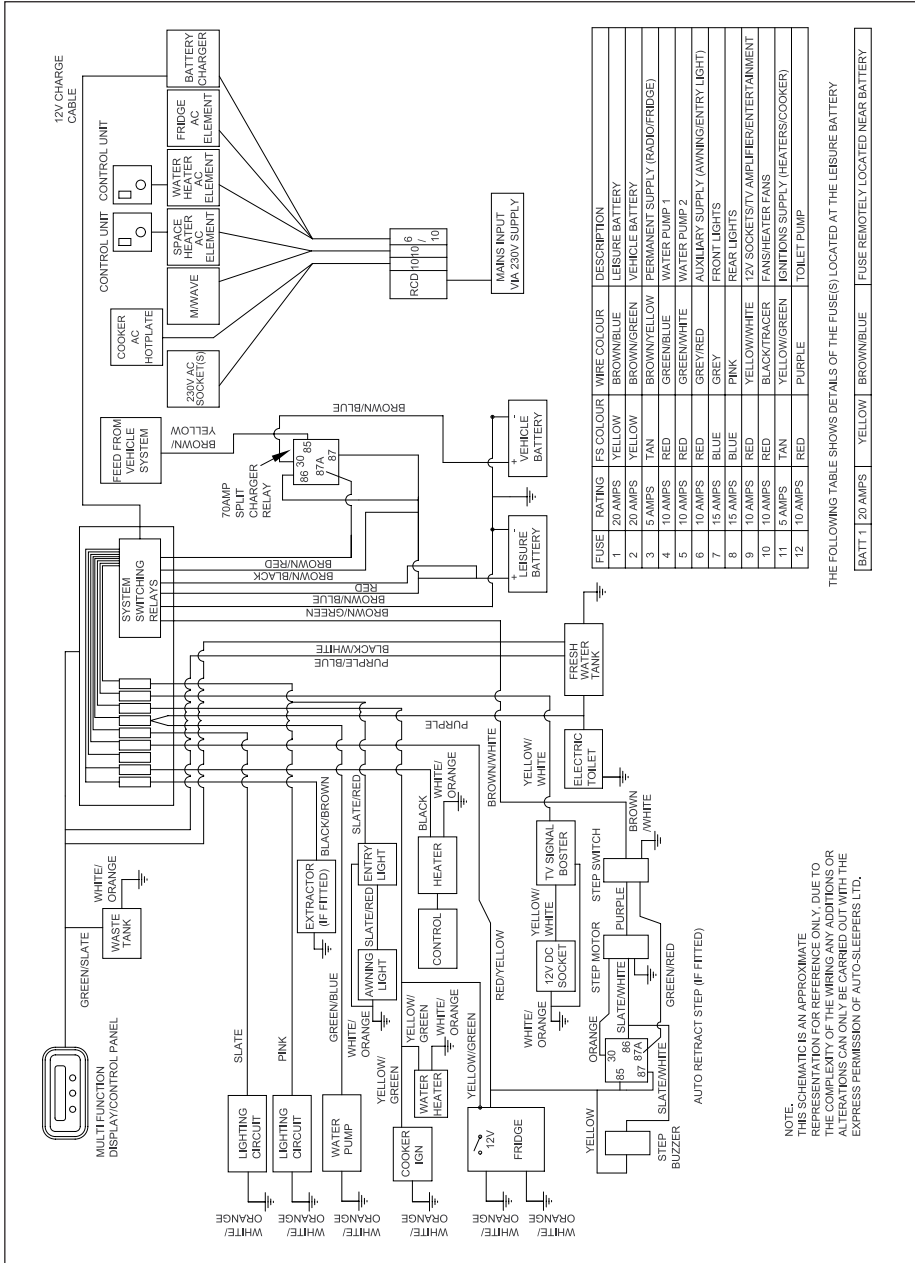

NOTE.
THIS SCHEMATIC IS AN APPROXIMATE REPRESENTATION FOR REFERENCE ONLY. DUE TO THE COMPLEXITY OF THE WIRING ANY ADDITIONS OR ALTERATIONS CAN ONLY BE CARRIED OUT WITH THE EXPRESS PERMISSION OF AUTO-SLEEPERS LTD.



TECHNICAL DATA

Base Vehicle Data

For all matters relating to the base vehicle, and particularly tyre pressures, refer to the base vehicle instruction book or if in doubt consult your local base vehicle commercial dealer.

Weights, Dimensions and Capacities

Before using your Auto-Sleeper you should be fully conversant with all matters relating to weights. The following definitions should be fully understood and then related to the tabulated base vehicle weight data.

Weights

Details of vehicle weights are found below, and are presented in the manner prescribed in the European Union Regulation 1230/2012.

Take care to ensure that heavy loads are stored low down in bed boxes and low cupboards, and distribute weight evenly side to side as far as possible.

Note 1: Please take care to ensure that you have allowed for the masses of all items you intend to carry in the motor caravan, e.g. passengers, optional equipment, essential habitation equipment and personal effects such as clothing, food, pets, bicycles, sailboards, sports equipment, etc.

Note 2: Warning - Under no circumstances should the maximum technically permissible laden mass of this motor caravan, or its individual axles, be exceeded.

Note 3: The Mass in Running Order contains provision for the mass of liquids, gas etc (see definition). Part of this provision can be utilised as additional payload if, for example, you wish to travel with water tanks empty or with no gas cylinders.

DEFINITIONS

Maximum Technically Permissible Laden Mass (MTPLM)

The Maximum Technically Permissible Laden Mass is a figure given by the manufacturer of the base vehicle. It is the combined maximum permitted weight of the vehicle and all of its contents, both inside and out. The MTPLM is unaffected by the Auto-Sleeper conversion.

Mass in Running Order (MRO)

The Mass in Running Order is defined as the mass of the vehicle equipped to the manufacturer's standard specification and including the following:

- Driver (assumed to be 75 kg, 11st 12lb)
- Fuel tank - 90% full
- Mains electricity connection cable

Note: The MRO assumes that the freshwater tank is empty. If you travel with water in the freshwater tank then the User Payload will reduce accordingly.

All other optional equipment whether on the base vehicle or part of the conversion is excluded from the mass in running order.

Mass of the User Payload

The Mass of the User Payload is the difference between the MPTLM and the MRO. It is the vehicle's carrying capacity for everything placed in or on it, including the passengers (but excluding the driver who is already included in the MRO).

Everything listed in italics below must be subtracted from the payload.

Mass of the Conventional Load

The Conventional Load is the mass of the passengers carried and must be subtracted from the payload. The "EU standard person" weighs 75kg (11st 12lb). The user should adjust the figure according to the mass and number of passengers carried. Motorhome Manufacturers designate passenger seats as being suitable for travelling, and provide seat belts accordingly. Multiplying the weight of the passengers by the number of passengers gives the Conventional Load. Please note that a driver (at 75kg, 11st 12lb) is included in the MRO.



Essential Habitation Equipment

The Essential Habitation Equipment is defined as the items of fluids required for the safe and proper functioning of habitation equipment. This means the mass of a full tank of LPG and the water in the toilet system flush tank.

This must be subtracted from the User Payload.

Auto-Sleepers include the low voltage (230V) connection cable and the habitation battery in the mass in running order.

Options, Personal Effects and Accessories

When options, personal effects and accessories are fitted or carried the mass must be subtracted from the user payload. All optional equipment whether on the base vehicle or part of the conversion is excluded from the mass in running order. Personal effects are any items of any description carried by the vehicle.

To determine accurately if a vehicle is exceeding one of its maximum technically permissible laden masses, the vehicle with all of its load (that is passengers, contents, luggage and external load) should be weighed on a weighbridge.

Gross Train Mass (GTM)

If you are towing a trailer with your Auto-Sleeper, the Gross Train Weight is the maximum allowable weight of the towing vehicle, the trailer and the mass of every item carried. The figure is shown on the Vehicle Masses data chart on the next page. Please check your driving licence to ensure you are allowed to drive a vehicle combination at this weight.

Maximum Braked Trailer Mass (MBTM)

This is the maximum allowable weight of the trailer together with its load, provided the trailer has a braking system, which complies with European trailer braking legislation. The figure is shown on the Vehicle Masses data chart on the next page

MTPLM of the Axles

The individual axles also have MTPLM's. The sum of the two axle MTPLM's usually exceeds the overall vehicle MTPLM, but this does not mean you can load each axle to its maximum, because doing so would exceed the overall MTPLM of the whole vehicle.



VEHICLE MASSES

All masses in kg

Payload calculations to EU Regulation 1230/2012

Engine: 2.1 TDCi	STANTON	STANTON With factory weight upgrade
	Automatic	Automatic
(Data for standard vehicle with no options)	Low Profile	Low Profile
Vehicle Designation	316 CDi	316 CDi
Maximum Technically Permissible Laden Mass (MTPLM)	3200	3500
Mass in Running Order (MRO)	2849	2849
Mass of the User Payload	351	651
Designated Passenger Seats (excluding driver)	1	1
Conventional Load @ 75kg per person	75	75
Essential Habitation Equipment	17	17
Personal Effects (specified minimum figure)	79	79
Payload remaining available for Personal effects/Options/Accessories	180	480
Optional Premium Pack	33	33
Optional Habitation Area Air Conditioning	33	33
Gross Train Mass	n/a	n/a
Maximum Braked Trailer Mass	n/a	n/a
Maximum Un-braked Trailer Mass	n/a	n/a
Maximum permissible static vertical load on the towball	n/a	n/a
Axles		
Mass of Front Axle, in Running Order	1320	1320
Mass of Rear Axle, in Running Order	1529	1529
MTPLM, Front Axle	1800	1800
MTPLM, Rear Axle	2000	2250

Note: The MRO is calculated with the freshwater tank empty. If you travel with water in the freshwater tank then the User Payload will reduce accordingly.



VEHICLE DIMENSIONS

All dimensions in mm

MODEL	STANTON
(Data for standard roof version)	Low Profile
Base Vehicle Manufacturer	Mercedes
Base Vehicle Model	316 CDi
Wheelbase	3250
DIMENSIONS	
Overall Length	5940
Overall Width (mirrors extended)	2660
Overall Width (mirrors folded)	2260
Overall Height	2850
Internal Height (maximum)	1960
Internal Height (minimum)	1920
Front Double Bed	2100 x 1400
Single Bed (nearside)	1930 x 700
Single Bed (offside)	1930 x 700
Rear Bed	n/a
Fresh Water Tank Capacity (litres)	71
Waste Water Tank Capacity (litres)	53
Gas, Refillable tank, LPG	20 Litres

IMPORTANT

To maximise the usage of fitted equipment in your motorhome it is essential that any accompanying manufacturers' literature is read fully. All recommended maintenance and preparation procedures should be followed. The information provided in this manual is only intended as a guide. If in any doubt consult your manufacturer appointed dealer, particularly before attempting to install extra equipment.

In the interests of safety, replacement parts for an appliance shall conform to the appliance manufacturer's specifications and should be fitted by him or his authorised agent.

MICROWAVE OVEN

Model: Daewoo KOR-6L6BD

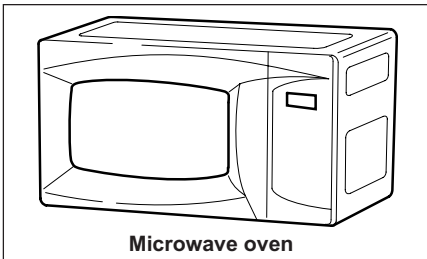

Microwave oven

Features:

- Oven volume in Litres: 20.
- Ten power steps.
- Maximum Wattage: 800.
- Duo plate system.
- Electronic time control.
- Touch control.

Separate operating instructions are supplied with this equipment.

THETFORD CAPRICE Mk III COOKER

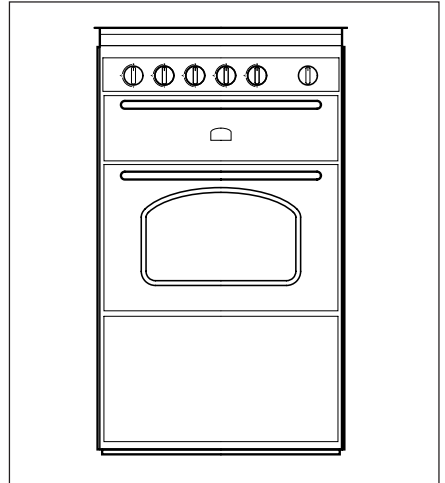

OPERATION

Ensure the gas cylinder is turned on.

In the event of a gas smell turn off at the cylinder or contact your nearest Auto-Sleeper dealer.

HOTPLATE BURNERS

CAUTION: Glass lids may shatter when heated. Turn off all burners and grill, and allow to cool, before shutting the lid.

Each burner is controlled individually and is monitored by a flame supervision device. In the event of the burner flames being accidentally extinguished, turn off the burner control and do not attempt to re-ignite the burner for at least one minute. The respective knob positions are shown in below:

To light the burner, press in and turn the knob

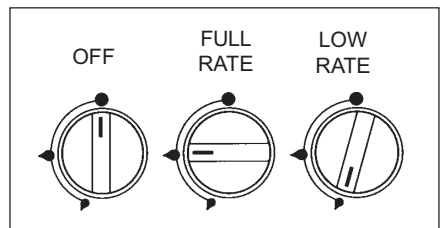



anti-clockwise to the full rate position and apply a light to the burner or press the ignition button if fitted. It is necessary to hold the knob depressed during ignition and for approximately fifteen seconds after the burner has lit to allow the flame supervision probe to reach temperature. Should the flame go out when the knob is released, the procedure should be repeated holding the knob depressed for slightly longer.

For simmering, turn the knob further anti-clockwise to the low rate position. To turn the burner off, rotate knob fully clockwise until the line or pointer on the knob lines up with the dot on the control panel. The burners on this appliance have fixed aeration and no adjustment is required. Depending on the gas being used, the burners should flame as follows:

- *Propane* - The flames should burn quietly with a blue/green colour with no sign of yellow tips.
- *Butane* - Normally on initial lighting, a small amount of yellow tipping will occur and then slightly increases as the burner heats up.

Although each burner will support pans from 10 to 22cm, care should be taken not to overload the appliance as reduced performance may result.

When using small pans, the flames should not spread beyond the base of the pan as this will reduce the efficiency of the burner.

GRILL

CAUTION: Accessible parts may be hot when the grill is used. Young children should be kept away.

1. Ensure gas cylinder/supply is connected and turned on. In the event of a gas smell turn off at gas cylinder/mains and contact supplier.
2. Remove all accessories and packing that may be in the grill including any plastic coating that may be protecting the grill cavity surfaces. Clean the interior before using it for the first time, use soap and water and rinse carefully.
3. To light: Open door, push in the control knob and turn to full rate. Hold a lighted match or taper to the burner and push the control knob in and hold. The burner should ignite and the control knob should be held in for 10-15 seconds before release. If the burner goes out, repeat procedure holding control knob for slightly longer.
4. For models fitted with spark ignition the procedure is similar except that the burner can be ignited by depressing the ignition button which is located on the fascia. Ignition must be carried out with the door open, and if the burner has not lit within 15 seconds the control knob should be released and the grill left for at least one minute before a further attempt to ignite the burner.
5. Please note the grill must only be used with the door open.
6. On first use of the grill, it should be heated for about 20 minutes to eliminate any residual factory lubricants that might impart unpleasant smells to the food being cooked. A non-toxic smoke may occur when using for the first time so open any windows and turn on mechanical ventilators to help remove the smoke.
7. Although the grill does heat up quickly, it is recommended that a few minutes preheat be allowed.
8. Flame Failure Device (FFD): the grill burner is fitted with a flame sensing



probe which will automatically cut off the gas supply in the event of the flame going out. In the event of the burner flames being accidentally extinguished, turn off the burner control and do not attempt to re-ignite the burner for at least one minute.

9. It is normal for the flames on this burner to develop yellow tips as it heats up, particularly on Butane.
10. Variation in cooking can be achieved by using the control knob to regulate the heat setting. In addition, the grill pan trivet can be reversed or removed to give a greater choice of grilling height. Always use the highest trivet position for fast toasting.
11. To turn off: turn the control knob until the line on the control knob is aligned with the dot on the control panel. Always make sure the control knob is in the off position when you have finished grilling.

OVEN

1. Ensure gas cylinders/supply is connected and turned on. In the event of a gas smell turn off at gas cylinder/mains and contact supplier.
2. Remove all accessories and packing that may be in the oven including any plastic coating that may be protecting the oven cavity surfaces. Clean the interior before using it for the first time, use soap and water and rinse carefully.
3. To light: open door, push in the control knob and turn to gas mark 9. Hold a lighted match or taper to the burner and push the control knob in and hold. The burner should ignite and the control knob should be held in for 10-15 seconds before release. If the burner goes out, repeat procedure holding control knob for slightly longer.
4. For models fitted with spark ignition the procedure is similar except that the burner can be ignited by depressing the ignition button which is located on the fascia. Ignition must be carried out with the door open, and if the burner has not lit within 15 seconds the control knob should be released and the oven left for at least one minute before a further attempt to ignite the burner.
5. Place the oven shelf in the required position and close the door. Set control knob to approximately gas mark 5 and heat the oven for about 30 minutes to eliminate any residual factory lubricants that might impart unpleasant smells to the meals being cooked. A non-toxic smoke may occur when using for the first time so open any windows and turn on mechanical ventilators to help remove the smoke.
6. Although the oven does heat up quickly, it is recommended that a 10 minutes preheat be allowed. The oven should be up to full temperature in about 15-20 mins.
7. To turn off: turn the control knob until the line on the control knob is aligned with the dot on the control panel.



8. Flame Failure Device (FFD): the oven burner is fitted with a flame sensing probe which will automatically cut off the gas supply in the event of the flame going out.
9. Shelf: the shelf has been designed to allow good circulation at the rear of the oven and are also fitted with a raised bar to prevent trays or dishes making contact with the back of the oven. To remove a shelf, pull forward until it stops, raise at front and remove.

WARNINGS:

All pans should be mounted centrally over the burners, even when cooling, to protect adjacent walls.

Do not lower hob cover until hobs have cooled.

On no account should these appliances be used as a space heater.

Do's and Don'ts

- Do** read the user instructions carefully before using the appliance for the first time.
- Do** allow the oven to heat before using for the first time, in order to expel any smells before the introduction of food.
- Do** clean the appliance regularly.
- Do** remove spills as soon as they occur.
- Do** always use oven gloves when removing food shelves and trays from the oven.
- Do** check that controls are in the off position when finished.
- Do not** allow children near the cooker when in use. Turn pan handles away from the front so that they cannot be caught accidentally.
- Do not** allow fats or oils to build up in the oven trays or base.
- Do not** use abrasive cleaners or powders that will scratch the surfaces of the hotplate and oven.
- Do not** under any circumstances use the oven as a space heater.

Temperature control

The temperature in the oven is controlled by a thermostatic gas tap and is variable over the range 130 deg C to 240 deg C.

Approximate temperatures for the settings on the control knob are shown in the following table. The temperatures indicated refer to the centre of the oven and at any particular setting the oven will be hotter at the top and cooler towards the base. The variation between the top and centre, and centre to bottom is approximately equivalent to one gas mark. Good use can be made of the temperature variation in that several dishes requiring different temperatures may be cooked at the same time. In this way maximum benefit can be obtained from the gas used to heat the oven. Care should be taken not to overload the oven, adequate spacing being used to allow free circulation for heat.

Cooking guidelines

IMPORTANT - The pan supplied with the oven is multifunctional, for use in grill and oven. The handle design allows for removal or insertion whilst the pan is in use. Always remove the handle when in use.

Larger items may adversely affect the circulation and heat distribution. Best results will be obtained by the shelf positions in this guide. It is not necessary to preheat the oven but advisable for a range of dishes. The oven is capable of full temperature in 15-20 minutes.

Most cookery books give details of the shelf positions and gas mark settings for each recipe. If in doubt about a recipe you intend to use, study the recipe carefully then find a similar dish in our guide and use our shelf position and gas mark setting recommendation. Shelf positions are from the top down. When roasting with aluminium foil care must be taken that the foil does not impair circulation or block the oven flue outlet.



Gas Mark	Temperature			
1/4 - 1/2	265-275°F	130-135°C	Very cool	Meringues
1	285	140	Cool	Stewed fruit
2	300	150	Cool	Rich fruit cake
3	330	165	Warm	Baked custard
4	355	180	Moderate	Victoria sandwich
5	385	195	Fairly hot	Whisked sponges
6	410	210	Hot	Shortcrust pastry
7	430	220	Hot	Bread, scones
8	445	230	Very hot	Puff pastry
9	465	240	Very hot	Quick browning
Dish				
	Gas Mark	Shelf Position	Cooking Time	
Scones	7	2	8-15 mins	
Small cakes	5	2	15-25 mins	
Victoria sandwich	4	2	20-30 mins	
Very rich fruit cake	2	2	Approx. 60 mins per 500g	
Puff pastry	8	2	15-30 mins	
Flaky pastry	7	2	15-30 mins	
Shortcrust pastry	6	2	15-55 mins	
Shortbread fingers	3	2	25-30 mins	
Ginger nuts	5	2	12-16 mins	
Rice pudding	2	3	100-120 mins	
Baked custard	3	3	50-60 mins	
Fruit crumble	5	3	30-40 mins	
Beef	3	3	25 mins per 500g plus 25 mins	
	7	3	15 mins per 500g plus 20 mins	
Pork	3	3	30 mins per 500g plus 35 mins	
	7	3	25 mins per 500g plus 25 mins	



ELECTRIC HOTPLATE

Ensure the electricity is switched on.

CAUTION: Glass lids may shatter when heated. Turn off the hotplate and allow it to cool before closing the glass lid.

CAUTION: Remove all spillage from the surface of the glass lid before opening.

The hotplate control is numbered from 1 to 6. To turn it on, rotate the knob either clockwise or anti-clockwise to the required position. Position 1 is the coolest setting. To turn the hotplate off, rotate the knob until the line or pointer on the knob lines up with the zero on the control panel.

The hotplate is a sealed construction and transfers heat through conduction. For maximum efficiency a correctly sized pan with a flat heavy gauge base should be used. Pan size should be the same or slightly larger (up to 1in/2.5cm oversize).

Before using your hotplate for the first time, we recommend that you prime it and then season it. To prime it, switch on the hotplate for a short period, without a pan, to harden and burn off the coating. Use a medium to high setting for 3-5 minutes. A non toxic smoke may occur during this process. Allow it to cool, then season.

To season, first heat the hotplate for 30 seconds on a medium setting, then switch off. Pour a minimal amount of unsalted vegetable oil onto a clean dry cloth or paper towel, and apply a thin coat of oil to the hotplate surface. Wipe off any excess oil, then heat the hotplate on a medium setting for one minute. Occasional seasoning will help to maintain its appearance.

Leaks

If a smell of gas becomes apparent, the supply should be turned off at the cylinder IMMEDIATELY. Extinguish naked lights including cigarettes and pipes. Do not operate electrical switches. Open all doors and windows to disperse any gas escape. Butane/Propane gas is heavier than air, any escaping gas will therefore collect at low level. The strong unpleasant smell of gas will enable the general area of the leak to be detected. Check that the gas is not escaping from an unlit appliance. Never check for leaks with a naked flame, leak investigation should be carried out using a leak detector spray.



DOMETIC CK2000 AIR CIRCULATING COOKER HOOD

With 50 m³/h capacity 'Circulair' performs more efficiently than conventional cooker hoods - while offering a low DC-consumption of only 5 watts.

A roof mounted ventilator is no longer necessary as the cleaned air is returned downwards while the suction is concentrated along the edges. This creates an air-dome which stops fumes escaping.

Features:

- Lateral air suction ensures efficient performance with 50 m³/h.
- Easy installation as no roof-mounted ventilator is necessary.
- With 2 fan-speed regulation and integrated halogen lights.
- Washable grease filter and exchangeable carbon filter.
- Snap-on releases for easy access to filters and lamps.

Technical data:

Weight	2.2 kg
Height	55 mm
Width	400 mm
Depth	280 mm
Halogen lamps	2 x 10W
Lamps (V)	12

SEITZ CONCERTINA BLINDS

The windows of the habitation area are fitted with concertina blinds and flyscreens.

The flyscreens pull down from the top, the concertina blinds up from the base and a combination of both may be achieved by clipping both units together in the centre to adopt the required position. It should be remembered that both the flyscreens and concertina blinds are relatively delicate and those in the living area should be treated with care. They should be kept in a dry and dust-free state, it is advised that the mechanisms are only lightly lubricated when they become a little stiff and inoperative - otherwise no maintenance is needed.

The concertina blinds are manufactured from a paper type material and thus cleaning solvents and aerosols should be kept well clear from them.

Unlike Seitz roller blinds, they will not need to be re-tensioned - any problems that should arise should be addressed to your Auto-Sleeper dealer or the Motorhome Service Centre at Willersey.



WARM AIR & HOT WATER HEATING

A Truma liquid gas Combi 6E warm-air heater, with integrated hot water boiler, is fitted and operates on LPG and/or 230V electricity depending on the chosen mode of operation.

NOTE: The heater is able to operate while the vehicle is in motion. For safety reasons when re-fueling, the heater will turn off automatically when the engine is turned off. After the engine is re-started the heater will need to be re-started at the control panel.

In winter operation the heater can be used to heat the room and simultaneously warm water. If only warm water is required, select summer operation.

At a temperature of approximately 3 deg C the automatic frost control safety/drain valve will open and drain the boiler.

Three different options are available for operating the unit.

Gas operation only: Propane/butane for autonomous use.

Electrical operation only: 230V for stationary use on camp sites.

Mixed operation: Gas and electrical operation - only possible in winter mode.

Winter operation

In winter operation, the unit automatically selects the required power setting according to the temperature difference between the temperature set on the control panel and the current room temperature. When the boiler is filled, the water is automatically heated as well. The water temperature depends on the selected operation mode and the heater output.

All three energy selection options can be used for winter deployment.

With gas operation the unit automatically selects the output level that is required.

Depending on the fuse protection at the camping site, power of 900W (3.9A) or 1800W (7.8A) can be manually selected for electrical operation.

If more output is required (e.g. heating up or low outside temperatures) gas or mixed operation should be selected so that enough heating power is always available.

With mixed operation, 230V electrical operation is preferred if the power requirement is low (e.g. for maintaining the room temperature). The gas burner is not enabled until the power requirement is higher, and is the first to switch off during heat-up operations.

Summer operation (boiler operation only)

Gas operation or 230V electrical operation is used for hot water preparation. The water temperature can be set to 40 deg°C or 60°C.

With gas operation the water is heated at the lowest burner setting. Once the water temperature is reached, the burner switches off.

Depending on the fuse protection at the camping site, power of 900W (3.9A) or 1800W (7.8A) can be manually selected for electrical operation.

Note: Mixed operation is not possible. With this setting the unit automatically selects electrical operation. The gas burner is not enabled.

Before operation

Note: Heating is possible without restrictions with gas, electrical and mixed operation, with or without water.

Check to make sure the cowl is unobstructed. Be sure to remove any covers that may be present.

Turn on the gas cylinder and open quick-acting valve in the gas supply line.

Check whether the power supply fuse protection on the camp site is adequate for the 900W (3.9A) or 1800W (7.8A) that have been selected using the power selector switch.

The cable drum must be fully unwound in order to prevent the power cable from overheating.



DISPLAY AND CONTROLS

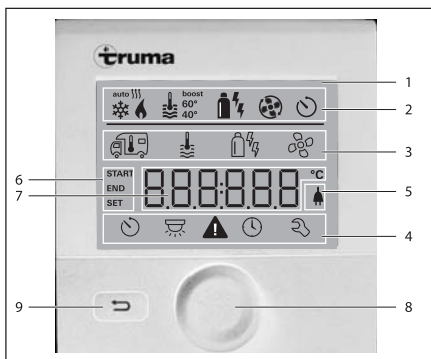

- 1 = Display
- 2 = Status bar
- 3 = Menu bar (upper)
- 4 = Menu bar (lower)
- 5 = 230V mains supply indicator (power)
- 6 = Time switch display
- 7 = Settings / Values
- 8 = Rotary push button
- 9 = Back button

Menus can be selected in lines (3 + 4) using the rotary push button (8) and settings made. The display takes place using a screen (1) with an illuminated background. The Back button (9) can be used to return from a menu.

Rotary push button

Setpoints and parameters can be selected, modified and saved by tapping on them using the rotary push button (8). Selected menu items flash.

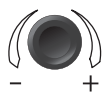

Rotate right (+)

- Menu is run through from left to right.
- Increase values.

Rotate left (-)

- Menu is run through from right to left.
- Decreases values.



Touching

- Accept (save) a selected value.
- Select a menu item, switch to setting level.



Press (3 seconds)

- Main switch function ON/OFF.

Back button

Pressing the Back button (9) returns you from a menu and discards settings. This means that the previous values are retained.

Start-up

Start/standby screen

After connecting the control panel to the mains power supply, a start screen is displayed after a few seconds.



If no entry is made for several minutes, the standby screen is automatically displayed.

Note: If the time has been set (see "Set time"), the display alternates between the time and the room temperature setting. If no time has been set, the room temperature setting is displayed continuously.

Functions

The functions in the menu bars (3, 4) of the control panel are selectable in any order. The operating parameters are shown on the status bar (2) and on the displays (5, 6).

Switch control panel on/off

- Press rotary push button for longer than 3 seconds.
- Previously set values / operating parameters are reactivated after switching on.
- If the heating system or the air conditioning system is without power for more than 2 hours, the control panel switches off automatically.
- The control panel deactivation procedures can be delayed by several minutes because of internal heating system after-runs.



Select setting level

- Tap rotary push button.

The display shows the setting level. The first icon flashes.

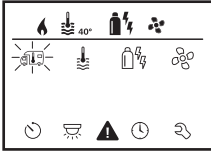

Change room temperature

- Select icon in menu bar (3) with rotary push button.
- Change by tapping in setting level.
- Select between heating system (HEATER) or air conditioning system (AC) using the rotary push button, depending on the unit that is connected.
- Tap rotary push button to confirm selection.
- Select desired temperature with rotary push button.
- Tap rotary push button to confirm value.

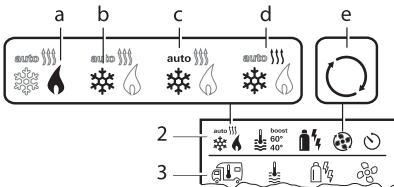

Heating system (HEATER)

Adjustable temperature range 5 - 30°C (steps of 1°C)

- a = Heating system * - Heating system is switched on.

Note: Quick temperature change using rotary push button possible (in Stand-by screen).

Air conditioning system (AC)

Adjustable temperature range 16 - 31°C (steps of 1°C)

- b = COOL * - Air conditioning system is switched on
- c = AUTO - Air conditioning system is set to automatic
- d = HOT - Air conditioning system is in heating operation
- e = VENT - Air conditioning system is in air circulation mode

* This symbol flashes until the required room temperature has been reached.



Change hot water level

- Select icon in menu bar (3) with rotary push button.
- Change by tapping in setting level.
- Select desired level with rotary push button.
- Tap rotary push button to confirm value.

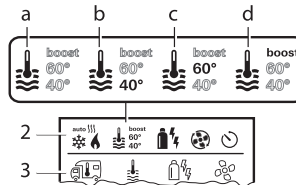

- a = Boiler * - Hot water generator is switched on.
- b = 40° ** - Hot water temperature 40°C
- c = 60° - Hot water temperature 60°C
- d = BOOST* - Targeted, rapid heating of boiler contents (Boiler priority) for a maximum time window of 40 minutes. Then the water temperature is kept at the higher level for two post-heating cycles (about 62°C). After reaching the water temperature, heating of the room continues.

* This symbol flashes until the required water temperature has been reached.

** A hot water temperature of 40°C can only be maintained with combined room and water heating for a limited time.



Select energy source

- Select icon in menu bar (3) with rotary push button.
- Change by tapping in setting level.
- Select desired energy source with rotary push button.
- Tap rotary push button to confirm value.

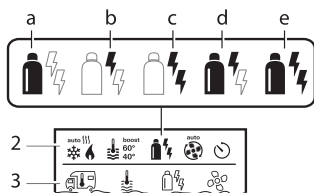

Icon Operating mode Energy mode

Icon	Operating mode	Energy mode
a	Gas/Fuel	Gas/Diesel
b	EL 1	Electrical
c	EL 2	Electrical
d	MIX 1*	Electric+Gas/Diesel
e	MIX 2*	Electric+Gas/Diesel

* Mixed mode

Note: As soon as the heating system is switched on (room temperature, hot water level active) the energy type that was selected for the previous heating procedure is displayed in the status bar.

Special features in mixed mode

Interruption of the mains voltage 230 V:

The heating system switches automatically into gas mode. As soon as the 230 V power supply has been restored, the heating system automatically switches back to mixed mode.

Fault in combustion procedure (e.g. lack of fuel).

Combi Gas The heating system switches automatically into electrical mode. If the heating system is to run in mixed mode again, the cause of the fault must be remedied. Switch heating system on and off again at control panel.



Select fan level

With connected heating / air conditioning system

- Select icon in menu bar (3) with rotary push button.
- Change by tapping in setting level.
- Select desired fan level with rotary push button.
- Tap rotary push button to confirm value.

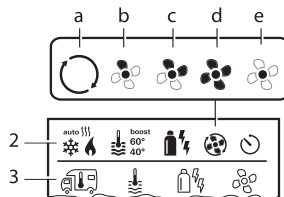

Heating system

Icon Operating mode Description

Icon	Operating mode	Description
-	OFF	Fan is switched off. (only selectable if no unit is in operation).
a	VENT*	Air circulation if not unit is in operation. 10 speed settings available.
b	ECO	Low fan level
c	HIGH**	High fan level
d	BOOST	Rapid room heating. Available if the difference between the selected and the actual room temperature is >10°C

* Can lead to additional motor wear depending on frequency of use.

** Fan setting "HIGH" results in higher power consumption, higher noise level and increased motor wear.

Note: As soon as the heating system is switched on (room temperature, hot water level selected) the status bar displays the fan level that was selected during the previous heating procedure. The factory setting is "ECO".



Air conditioning system

Icon Operating mode Description

- OFF Fan is switched off. (only selectable if no unit is in operation).
- a - -
- b LOW Low fan level
- c MID Medium fan level
- d HIGH High fan level
- e NIGHT Especially quiet fan operation



Set time switch

- The time switch can only be selected if the time has been set at the control panel.
- When air conditioning systems are being operated, the control panel time switch must only be used to clearly define the start and end time for a required period of time.
- If the time switch has been activated (ON), the deactivate time switch menu is displayed first (OFF).
- Select icon in menu bar (4) with rotary push button.
- Change by tapping in setting level.

Enter start time

- Set the hours then the minutes with the rotary push button.

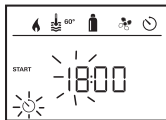

Enter finish time

- Set the hours then the minutes with the rotary push button.



If the start/end point was exceeded during entry, the operating parameters are not taken into consideration until the next start/end point has been reached. Until then, the operating parameters that have been set outside the time switch remain valid.

Set room temperature

- Select heating or air conditioning system using the rotary push button, depending on the unit that is connected.
- Tap rotary push button to confirm selection.
- Select required room temperature with rotary push button.
- Tap rotary push button to confirm value.

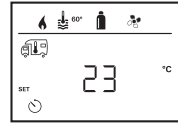

Set hot water level

- Select required hot water level with rotary push button.
- Tap rotary push button to confirm value.

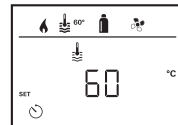

Select energy source

- Select required energy source with rotary push button.
- Tap rotary push button to confirm value.

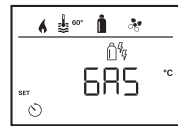

The select energy type menu is displayed if a heating system with electric heating elements is connected.

Select fan level

- Select desired fan level with rotary push button.
- Tap rotary push button to confirm value.

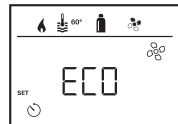

The select fan level menu is only displayed if heating system/hot water has been set.



Activate time switch (ON)

- Activate time switch with rotary push button (ON)
- Tap rotary push button to confirm value.
- The time switch remains active until it is deactivated (OFF), even for several days.
- If the time switch is programmed and active, the time switch icon flashes.

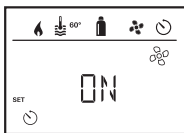

Deactivate time switch (OFF)

- Change by tapping in setting level.
- Deactivate with rotary push button (OFF)
- Tap rotary push button to confirm value.



Switch lighting on/off

Available when air conditioning system is connected

Aventa comfort or
Aventa eco

- Select icon in menu bar (4) with rotary push button.
- Change by tapping in setting level.
- Select required function with rotary push button.
 - 1 - 5 - Switch lighting on
Brightness selectable in 5 levels.
 - OFF - Switch lighting off

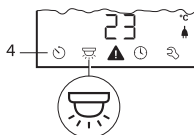

Set time

- The hour display flashes.
- Set the hours (24h mode) with rotary push button.
- The minutes display flashes when the rotary push button is tapped again.

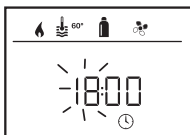

- Set the minutes with rotary push button.
- Tap rotary push button to confirm value.



Service menu

Display version number of connected units

Display version number of heating system, air conditioning system or control panel.

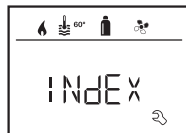

Change control panel background lighting

The background lighting has 10 different levels.



Change language

Select the required language from the languages available (e.g. English, German, French, Italian).



Calibrate temperature sensor (OFFSET)

The temperature sensor of the heating system can be individually adjusted to the size of the vehicle. The offset can be set in steps of 1°C within the range of -5 °C to +5 °C.



Reset to factory settings (RESET)

The reset function resets the control panel back to the factory settings. All settings will be deleted.

Confirm reset

- Tap rotary push button.





230 V mains power supply indicator

The icon signals that 230 V mains power supply is available.

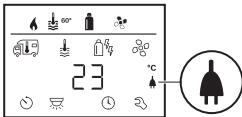

Note: Display is only possible in combination with a heating system Combi E CP plus ready which contains additional heating elements for electrical mode.

WARNING: In the event of a warning, a warning symbol appears in order to signal that an operating parameter has reached an undefined condition. In this case the device concerned continues to operate. As soon as the operating parameter is within the target range again, this symbol goes off again automatically.



Read out code of warning

- Select icon with rotary push button.
- Tap rotary push button.
The current warning code will be displayed. The cause of the warning can be determined using the fault list and eliminated.

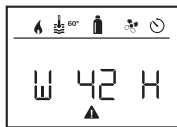

W = Warning
42 = Error code
H = Device
H = Heating system
A = Air conditioning system

Cause eliminated / return to setting level

- Tap rotary push button.

Cause not eliminated / return to setting level

- Press the return button.

Note: In this case the warning is not acknowledged on the control panel, and the warning symbol remains. The control panel remains in warning status. Other connected devices can be operated.

Fault

In the event of a fault, the control panel immediately jumps to the "Fault" menu level and displays the fault code of the fault.

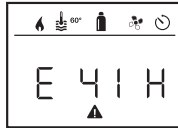

E = Fault
41 = Fault code
H = Device
H = Heating system
A = Air conditioning system

Cause eliminated / return to setting level

- Tap rotary push button.
- The respective unit is restarted.

Note: This can take several minutes because of internal after-run of connected units.

If the cause has not been remedied, the fault will occur again and the control panel will jump to the "Fault" menu level again.

Cause not eliminated / return to setting level

- Press the return button.

Note: In this case the fault is not acknowledged in the control panel, and the warning symbol remains. The device remains in fault state. Other connected devices can be operated.

Technical data

Display LCD, monochrome, with background lighting

Operating temperature range -25 °C to +60 °C

Storage temperature range -25 °C to +70 °C

Interface TIN bus

Power supply 8 V - 16.5 V

Power consumption max. 60 mA (100 % background lighting)
6.5 mA - 7 mA (Standby)

Standby current 3 mA (Off)

Maintenance

This unit is maintenance free. In order to clean the front panel, use a damp, non-scouring cloth. If this is not sufficient, use a neutral soap solution.

**Troubleshooting guide (Combi gas heating system)**

Fault code	Cause	Rectification
# 17	Summer mode with empty water tank Warm air outlets blocked Circulated air intake blocked	Switch unit off and allow to cool. Fill boiler with water. Check individual outlet apertures Remove blockage from circulated air intake
# 18	Gas pressure regulator iced up Butane content in the gas cylinder too high	Use regulator heater (EisEx) Use propane (Butane is unsuitable for heating, particularly at temperatures below 10°C.)
# 21	Room temperature sensor or cable defective	Please contact Truma Service
# 24	Risk of low voltage. Battery voltage too low < 0.4 V	Charge battery
# 29	FrostControl heating element has a short circuit	Disconnect heating element plug from electronic control unit. Replace heating element
# 41	Electronics blocked.	Please contact Truma Service.
# 42	Open window above cowl (window switch)	Close window.
# 43	Overvoltage > 16.4 V	Check battery voltage and voltage sources such as the charger.
# 44	Low voltage. Battery voltage too low <10.0 V	Charge battery. Replace obsolete battery if necessary
# 45	No 230 V operating voltage 230 V fuse defective Overheating protection has been triggered	Restore 230 V operating voltage Replace 230 V fuse. Reset overheating protection. Allow heating system to cool, remove connector cover and press reset button.
#112, #202 #121, #211	Gas cylinder or quick-acting valve in gas supply line closed	Check gas supply and open valves
#122, #212	Combustion air infeed or exhaust outlet is sealed	Inspect openings for contamination (slush, ice, leaves, etc.) and remove contamination if necessary.
#255	No connection between heating system and control panel Defective control panel cable	Please contact Truma Service.

If these actions do not remedy the problem, please contact the Truma Service.

FrostControl (safety/drain valve)

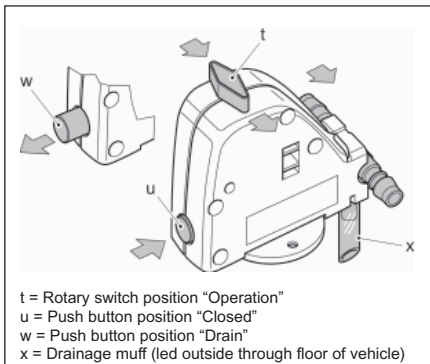

FrostControl is a currentless safety/drain valve. When there is a danger of frost, it automatically drains the contents of the boiler through a drainage muff. If excessive pressure is present in the system, pressure will be automatically intermittently equalised through the pressure relief valve.

Closing the drain valve

Check if the rotary switch is set to "Operation" (position t), meaning that it is parallel to the water connection and engaged.

Close the drain valve by activating the push button. The push button must engage in position (u) "closed".

It can be manually closed with the push button (position u) and then the boiler filled only when the temperature at the drain valve is above approximately 7°C.

Truma can provide a heating element (part no. 70070-01) as an accessory; it is inserted into FrostControl and warms it up to about 10°C when Combi is switched on. This means that the boiler can be filled after a shorter time, irrespective of the temperature in the installation compartment.

Automatic opening of the drain valve

When the temperature is below approximately 3°C at the drain valve, the drain valve will open automatically, the push button moves out (position w) and the water in the boiler drains out through the drainage muff (x).

Manual opening of the drain valve

Turn the rotary switch by 180° until it engages, whereby the push button moves out (position w). The water in the boiler drains out through the drainage muff (x).

The FrostControl drainage muff (x) must be free of contamination (slush, ice, leaves, etc.) at all times so the water can drain out easily. *No warranty given for frost damage.*

Filling the water heater

Check if the rotary switch for the drain valve (FrostControl) is set to "Operation", meaning that it is parallel to the water connection and engaged.

Close the drain valve by pushing the push button until it engages.

Note: When the temperature at FrostControl is below about 7°C, *first* switch on the heater to warm the installation compartment and FrostControl. After several minutes, when the temperature at FrostControl is above 7°C, the drain valve can be closed.

Switch on power for water pump (main or pump switch).

Open hot water taps in kitchen and bathroom (set pre-selecting mixing taps or single-lever fittings to "hot"). Leave the fittings open for as long as it takes for the boiler to displace the air and fill up, and the water to flow without interruption.

Note: If just the cold water system is being operated, without using the water heater, the heater tank also fills up with water. To avoid frost damage, the boiler must be drained through the drain valve, even if it was not operated.

WARNING: When connecting to a central water supply (rural or city mains), a pressure reduction valve must always be installed to prevent pressures above 2.8 bar from developing in the water heater.

Draining the water heater

Switch off power to water pump (main or pump switch).

Open hot water taps in kitchen and bathroom.

In order to check the water that is flowing out, place an appropriate container (capacity 10 litres) beneath the drain valve (FrostControl) drainage muff (x).

Turn the rotary switch on the drain valve by 180° until it engages, whereby the push button moves out and the drain valve opens.

Check whether all of the water in the boiler (10 litres) has been drained into the container via the drain valve.

There shall be no claims under guarantee for damage caused by frost!

Maintenance

Only original Truma parts may be used for maintenance and repair work!

The materials in the device that come into contact with water are drinking water safe.

Bio-film, deposits and limescale must be removed using chemicals to protect the unit from infestation by micro-organisms. Only Chloride-free products must be used in order to prevent damage to the unit.

The effectiveness of the use of chemicals to combat micro-organisms in the unit can be increased by heating the water in the boiler to 70°C at regular intervals.

To do this, on the control panel, select Gas Operation, then select Summer Operation 60°C.

Note: Once the water in the boiler has reached a temperature of 60°C, the burner will switch off. The unit must stay switched on for at least 30 minutes and no warm water may be removed. The residual heat in the heat exchanger will heat the water up to 70°C.

Fuses 12V

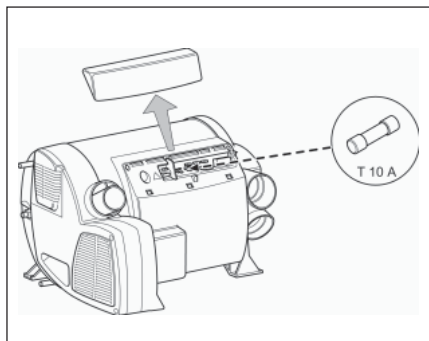

The fuse is in the electronics beneath the connection cover. Replace the unit's fuse only with an identical fuse.

Device fuse: 10A - slow - (T 10A).

Fuses 230V

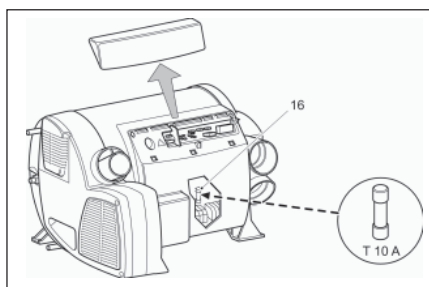

CAUTION: The fuse and the power supply lines must only be replaced by an expert!

WARNING: The unit must be disconnected from the mains (all poles) before opening the electronic housing lid.

The fuse in the power electronics (16) beneath the electronic housing lid.

This fine fuse must always be replaced with a fuse of the same type: 10A, slow, interrupting capacity "H".



Overheating protection 230V

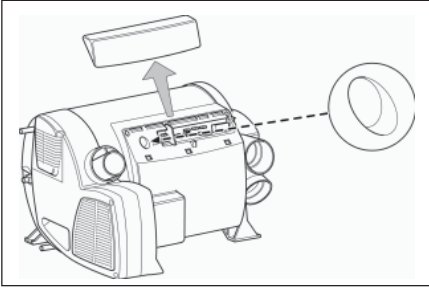

The 230V heating facility has a mechanical overheating switch. If the 12V power supply is interrupted during operation or during the after-run period, for example, the temperatures within the unit could activate the overheating protection.

To reset the overheating protection, allow heater to cool, remove connection cover and press red reset button.

WATER TANK HEATERS

If specified, electrically heated, thermostatically controlled, water tank heater blankets are fitted to enable operation of your vehicle in cold conditions.

Operation

- **Make sure that the tank heaters are only selected when there is liquid in the tanks.**
- Press the defrost button on the control panel when you know the ambient temperature will approach freezing. The LED will indicate that there is power to the circuit.
- If there is no liquid in the waste tank, the heater for it must be turned off using the isolation switch, ensuring that the LED is NOT lit. For exact location of the switch refer to the Location of Key Facilities chart.
- When the temperature in the tank drops to approximately 7°C the thermostat will turn the heating element 'ON'.
- When the contents of the tank rise to 18°C the thermostat will turn the system 'OFF'.

- Turn the control panel switch 'OFF' when draining fluid, connecting electrical hook up or starting a generator. This will prevent damage to the built-in thermostat.
- Turn the control panel switch 'OFF' when the ambient temperature remains above freezing.

Maintenance

Periodically conduct a visual check of the system to ensure cables, connections and the heater pads are as installed and have not been damaged or become disconnected.

REFRIGERATOR

Your vehicle is fitted with a Dometic absorption type refrigerator, which runs silently and is very efficient in its use of energy.

See documentation enclosed with vehicle for more detail.

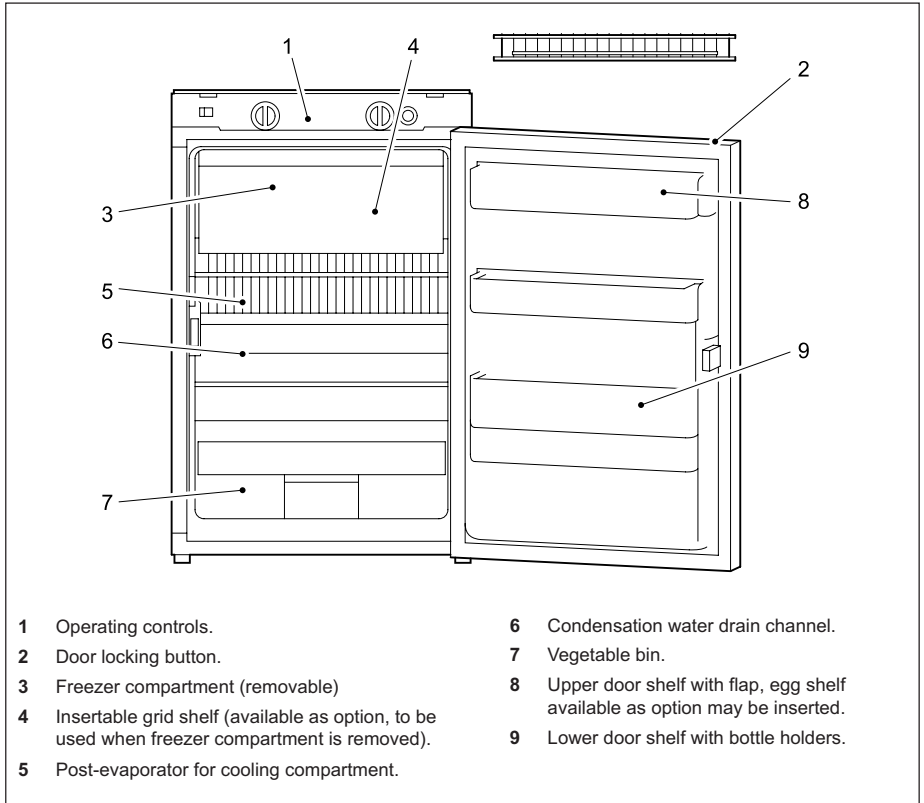

The refrigerator can operate in three power modes:

- Mains voltage (230V AC)
- Direct current voltage (12V DC)
- Gas (liquid gas, propane/butane)

Select the desired power mode using the mode button.

Cleaning

Before starting the refrigerator it is recommended that you clean it inside and repeat this at regular intervals. Use a soft cloth and warm water with a mild detergent. Then wipe out with clean water and dry thoroughly. Do not use soap or hard, abrasive or soda based cleaning agents. Do not allow the door seal to come into contact with oil or grease.

Maintenance

In order to comply with applicable gas standards, the gas unit and ventilation ducts must be checked by an authorized technical person at regular intervals, and a test certificate issued. It is the user's responsibility to arrange this test.

The gas burner must be inspected and cleaned as necessary, at least once a year.

Work on gas and electrical equipment shall be carried out by qualified personnel only.

This work can be carried out by the Auto-sleepers Service Centre at the annual habitation service, or after an extended shutdown period.

Operating controls

Dometic

<p>1 Power on switch / Energy selector switch (MODE).</p> <p>2 Temperature selection.</p> <p>3 Door opening (only when equipped with electrical door lock).</p>	<p>4 Indicator LED failure.</p> <p>5 Indicator LED door lock (optional).</p> <p>6 Indicator-LED / operating mode display.</p> <p>7 Temperature level display.</p>
---	---

Electrical operation

To start the refrigerator press the mode button (1) for 2 seconds. The LED of the previously selected operating mode will illuminate.

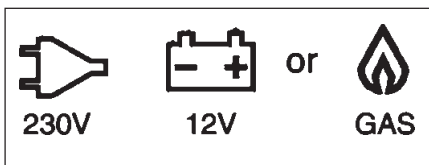

Change the operating mode by pressing the mode button (1) again, and the appropriate indicator

LED (6) will illuminate.

Gas operation (LPG)

Prior to starting the refrigerator in gas mode:

- Open the gas cylinder valve
- Open the isolation valve inside the vehicle for gas supply to the refrigerator

Press the mode button (1) several times until

the indicator LED (6) shows the gas flame. The ignition process is then activated automatically. Note that the ignition system will make 2 attempts with 25 seconds interval to light. If repeated attempts fail to start the operation, a fault is indicated (please refer to troubleshooting section).

Temperature setting

Select the desired cooling department temperature by pressing button 2, and the LED display (7) is illuminated. The scale starts with **MIN** position at the bottom LED position (small crystal = highest temperature) and climbs up to **MAX** position at the upper LED position (large crystal = lowest temperature). Note the temperature levels do not relate to absolute temperature values.

The refrigerator's performance is influenced by ambient temperatures. Please select the medium temperature setting for ambient temperatures between +15°C and + 25°C.

For temperatures below +10°C winter covers should be fitted to the outside vents.



Additional features

- The brightness of the display reduces after a few seconds if no other buttons are pressed.
- If the door is open, the interior light is switched off automatically after 2 minutes.
- Failures are indicated by flashing of the failure indicator LED(4).
- If the door is kept open for too long (more than 2 minutes), an acoustic signal is initiated (pulsing whistle tone).
- If the electronic control detects any failure, an acoustic signal (pulsing whistle tone) will sound. At the same time the display starts flashing (for troubleshooting, please see later section).

Door locking

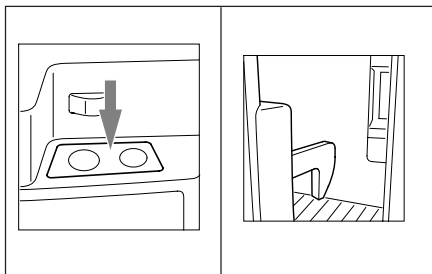

Open the door by pressing the locking button and pull open.

Shut the door again by pushing it to close. The snapping into the lock can be heard.

Note: If the vehicle is stationary for a long period, the locking hook may be clamped by means of a lockbar. The door may now be opened by just pulling it without need of pressing the locking button. See below.

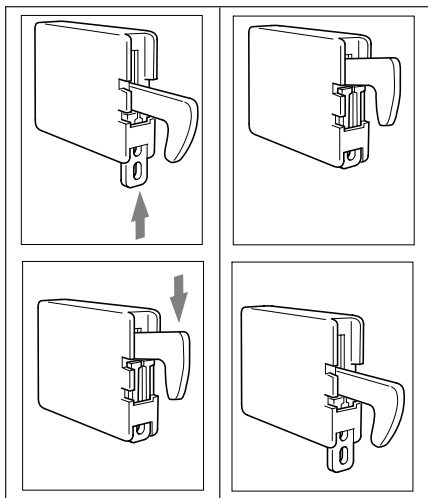

Caution: As a basic rule, shut and lock the door before starting your journey.

Positioning the shelves

The shelves may be pulled out by smoothly lifting them, and may be positioned as desired.

Removable freezer compartment

The freezer compartment may be removed to enlarge the cooling compartment.

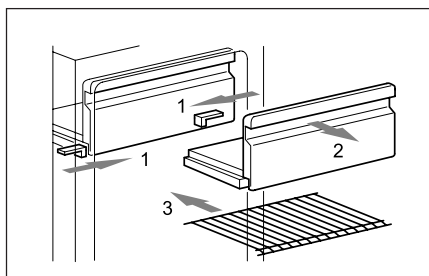

Unlock the freezer compartment on both sides (1)



Pull the freezer compartment out (2) and store safely.

An additional shelf (3) may be installed, if required. This may be obtained from Dometic.

Storing food in the cooling compartment

- Switch the refrigerator on approx 12 hours before filling
- Always store pre-cooled food. Make sure that food is well cooled when it is bought and also when transporting it – use insulated cool bags.
- Keep the door open for the minimum time possible.
- Food must be packed, in closed containers or wrapped in foil, and stored separately from each other, to prevent drying out or odours.
- Allow foods that have been warmed to cool down before storing.
- Ensure that air circulation of the cooling unit is not obstructed. Keep the ventilation grilles free from obstructions.

Storing food in the freezer compartment

- Do not keep carbonated drinks in the freezer.
- The freezer compartment is suitable for making ice cubes and for short term storage of frozen foods. It is not suitable as a means of freezing foods.

Note: When ambient temperatures are lower than +10°C and the refrigerator is exposed to these temperatures for extended periods an even regulation of freezer temperature cannot be guaranteed for system-related reasons. This can cause the temperature in the freezer to rise and stored goods to melt.

Making ice cubes

Ice cubes are best made over night, when the refrigerator has less work to do and has more reserves.

Defrosting

In time, frost builds up on the fins inside the refrigerator. A layer of frost thicker on one side may occur but does not mean a

malfunction. When this layer of frost is about 3mm thick, the refrigerator should be defrosted. To do this:

- Switch off the refrigerator as described later.
- Remove all food and the ice cube tray.
- Leave the door open to allow air to enter and prevent formation of mildew.
- After defrosting (freezer compartment and fins free of frost), wipe both cooling compartments dry with a cloth.

Note: Water thawing in the main compartment of the refrigerator runs into a container at the back of the refrigerator, from where it evaporates.

CAUTION: The layer of ice must never be removed forcibly, nor may defrosting be accelerated using a heat source.

Shutting off the refrigerator

Press the mode button (1) and keep pressed for 2 seconds. The display will disappear and the appliance is fully switched off.

Release the locking mechanism of the door lock by pushing it and shift it to the front. If the door is shut in this position, a small gap is maintained to prevent the formation of mildew.

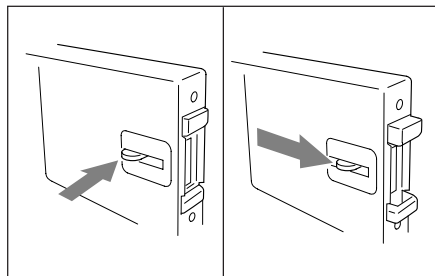

If the refrigerator is taken out of service for an extended period, close the isolation tap and the gas cylinder valve.

Winter operation

In winter, check that the ventilation grilles and the exhaust duct have not been blocked by snow, leaves etc. When the outside temperature falls below +10°C the winter







Covers should be fitted. This protects the unit from excessively cold air which could have adverse effects on the performance of the unit.

Note: The winter covers should also be attached if the vehicle is taken out of service for an extended period, or while it is being cleaned on the outside.

Failure display

Your refrigerator will indicate a malfunction by flashing of the failure indicator LED (4) and one of the other display lights. The chart below shows the meaning of these.

Display:	Failure:
 LED is flashing	230V mode: "230V" not available or voltage too low
 LED is flashing	12V mode: "12V" not available or voltage too low
 LED is flashing	GAS/Auto mode: Flame not ignited
All temperature setting LEDs are flashing	Temperature sensor defective, refrigerator work on mid temperature setting
 LED + all temperature	230V - Heating element defective
 LED + all temperature setting LEDs are flashing	12V - Heating element defective



Troubleshooting

Before contacting your dealer or authorized service centre, please check whether:

- The instructions for correct operation of the refrigerator have been observed.
- The refrigerator is standing level.
- It is possible to operate the refrigerator with any available power source.

Failure: The refrigerator does not cool sufficiently

<i>Possible cause</i>	<i>Action you can take</i>
• Inadequate ventilation to the unit.	• Check that the ventilation grilles are not covered.
• Thermostat setting is too low.	• Set thermostat to a higher level.
• The condenser is heavily frosted.	• Check that the refrigerator door closes properly.
• Too much warm food has been stored within short period of time.	• Allow warm food to cool down before storage.
• The appliance has been running for only a short period of time.	• Check whether the cooling compartment works after approx. 4-5 hours.
• Ambient temperatures too high.	• Regularly remove ventilation grilles.

Failure: The refrigerator does not cool in gas operation mode

<i>Possible cause</i>	<i>Action you can take</i>
• Gas cylinder empty.	• Change gas cylinder.
• Is the upstream shut-off device open?	• Open shut-off device.
• Air in the gas pipe?	• Switch off the appliance and start again. Repeat this procedure 3-4 times, if necessary.

Failure: The refrigerator does not cool in 12V operation

<i>Possible cause</i>	<i>Action you can take</i>
• On-board fuse defective.	• Fit new fuse.
• On-board battery discharged.	• Check battery, charge it.
• Engine not running.	• Start engine.
• Heating element defective (please also refer to failure indication).	• Please inform the Dometic Customer Services.



Troubleshooting (continued)

Failure: The refrigerator does not cool in 230V operation

Possible cause

Action you can take

- | | |
|--|--|
| • On-board fuse defective. | • Fit new fuse. |
| • Vehicle not connected to mains supply voltage. | • Make a connection to a mains power supply. |
| • Heating element defective (please also refer to failure indication). | • Please inform the Dometic Customer Services. |
-

Technical data

Model number: RM8501

Gross capacity

With freezer compartment in place: 90L cooling compartment / 8L freezer compartment

With freezer compartment removed: 96L cooling compartment

Power rating: Mains / battery: 125W / 120W

Energy consumption (over 24 hours at average ambient temperature of 25°C)

Electricity: 2.5 kWh

Gas: 270 gm



THETFORD CASSETTE C-200 CWE TOILET

Introduction

The Thetford Cassette C-200 CWE is functional and incorporates modern styling with home like features. The unit is an integral part of the motorhome bathroom.

The Thetford Cassette C-200 CWE is constructed of high quality plastics for durability and has a high gloss finish that is easy to clean and maintain. The unit consists of two sections, a permanently installed toilet system and a slide out waste holding tank - the Cassette.

The toilet section includes a rotatable bowl, a removable seat, and a control unit with a flush button and a waste level warning device. The valve blade handle is located under the bowl.

The cassette is located underneath the toilet and is removed for emptying from the outside of the vehicle through an access door. A rotating pour-out spout, automatic holding tank vent, air release valve, valve blade, carrying handles and hand grips are incorporated into the cassette. A sliding cover guarantees optimum hygiene.

Features:

- Removable seat and cover.
- Rotatable bowl.
- Valve blade handle: opens and closes valve blade manually.
- Flush button: activates flush.
- Waste level indicator: indicates when cassette requires emptying.
- Rotating pour-out spout: makes emptying cassette easy and convenient.
- Automatic cassette vent: vents the cassette when inserted in the toilet. This prevents over pressure in the cassette.
- Upper-carrying handles: makes carrying and emptying easy.
- Sliding cover: opens and closes automatically when sliding the cassette in and out. Guarantees optimal hygiene.
- Valve blade and blade seal.

- Vent button: vents the cassette to avoid splashing while emptying.
- Handgrip.
- Valve blade opener.
- Access door. Locks from outside the motorhome.

Preparing for use

Following is a brief illustrated step by step guide. For more detailed information please refer to manufacturers literature.

CAUTION (step 4): Warmer weather or longer intervals between emptying the waste tank may require additional toilet fluid. Use only Thetford toilet fluid to achieve the best results. Never add toilet fluid directly into the toilet bowl.

CAUTION (step 14): Do not depress air release valve button until pour out spout is facing downwards.

Emptying the waste holding tank

The cassette capacity is approx. 17 litres and the tank should be emptied when the waste-level warning device comes on. This will occur when the tank contains more than 15 litres of waste.

Note: After the warning device comes on, the capacity remaining is equal to approximately 5 uses.

CAUTION: Do not allow the waste cassette to become overfilled. See trouble shooting section for emergency emptying procedure.

Note: Some vehicles are equipped with water pumps supplying high water pressure, which can result in having an over flowing problem. It is possible to use the flush restrictor supplied with the toilet (packed together with the instruction manual) by installing it in the water tube at the connection level.

Rinse the holding tank with clean water. Prepare the cassette for use again by following steps 1 to 6. Replace the holding tank and lock the access door.

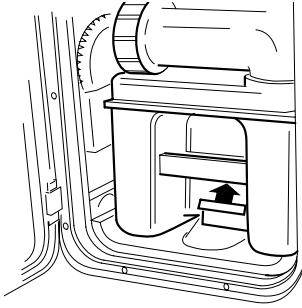

1 - Open access door and pull retaining clips upward.

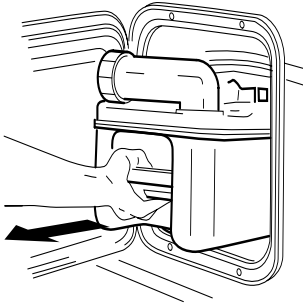

2 - Remove cassette by pulling straight out. When cassette hits stop, tilt downwards

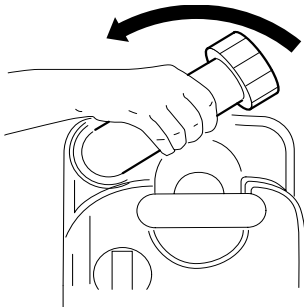

3 - Position tank vertically and swivel pour-out spout upwards.

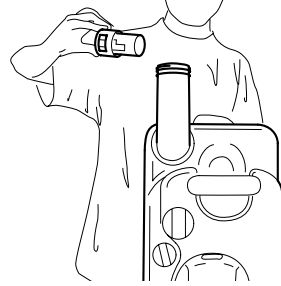

4 - Remove dosage cap and pour-out spout. Add toilet fluid in the dosage cup. Add approx. 2L of water through spout to cover tank bottom. Replace cap, return pour-out spout to original stored position.

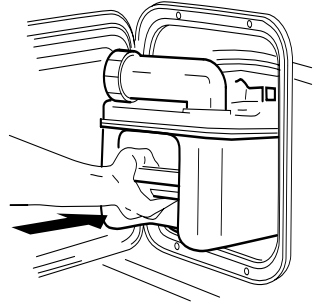

5 - Slide the holding tank into position through access door. Never force insertion as this can cause damage to the toilet.

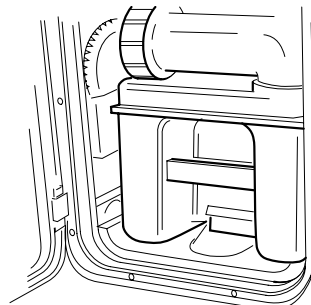

6 - Make sure the retaining clip secures the holding tank. Close and lock the access door.

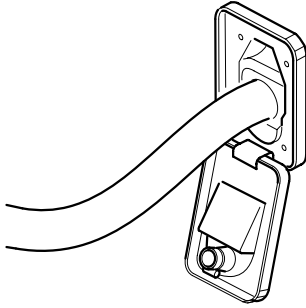

7 - Open water fill door and add 50ml. of Aqua Rinse. Then fill the tank with fresh water using a jerry can or hose. Tank capacity is 7 litres.

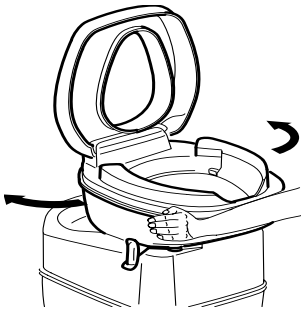

8 - Turn the bowl into the most comfortable position, when necessary.

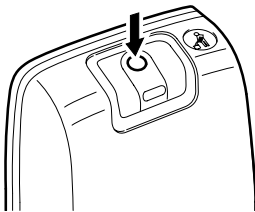

9 - Before using the toilet, we recommend to add some water to the bowl by pressing the flush button. Release button to stop.

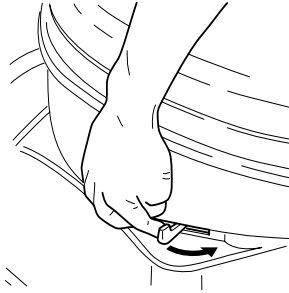

10 - After use, open the blade, by pushing the blade handle in an anti-clockwise direction and press the flush button.



11 - After flushing, close the blade by pushing the blade handle clockwise. The toilet may also be used with the valve blade open, which allows the waste to pass directly into the holding tank.

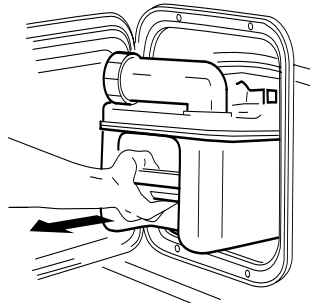

12 - Open access door and remove holding tank. The holding tank can only be removed when valve blade is closed.

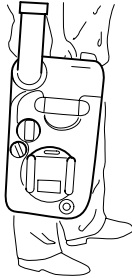

13 - Carry the holding tank to a normal household toilet or authorised disposal point. Place holding tank in vertical position and rotate pour-out spout upwards.

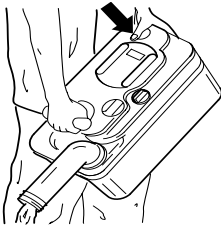

14 - Remove measuring cap. Grasp unit by upper carrying handle nearest pour-out spout. Place other hand on upper rear hand grip so that the vent button can be depressed with thumb while emptying. This ensures a smooth outflow of tank contents.

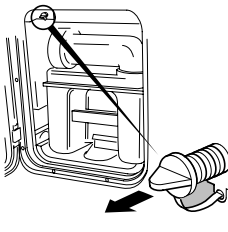

15 - Once the pump has been cleared of water place appropriate size container under the drain plug. Empty any remaining water from the fresh water tank by taking out the drain plug. Clean the seals and lubricate them where appropriate after drying.

Winterising/Storage

The Thetford Cassette C-200 CWE is easily winterised for storage. If the toilet is connected to a separate water tank, drain the tank. When the motorhome water tank is empty, press the flush button until the water stops flowing. Empty the cassette. If the toilet is connected to a central water tank, open the electric valve by pushing the flush button while draining the water supply system of the motorhome. Empty the cassette. Leave the blade of the cassette open. Do not replace cap on spout, this helps to keep the cassette dry.

Cold weather use

The cassette can be used in cold weather when the motorhome is heated. When the vehicle is not heated for more than a day (or a night), winterise the cassette.

High Altitude and hot weather use

Changes in altitude during driving, and large temperature variations give no problems as long as the cassette is inserted into the toilet. The automatic cassette vent will depressurise that tank when there is over or under pressure. High temperatures may require additional Thetford toilet fluid.

Cleaning and maintenance

To clean the seal and blade, the use of Thetford bathroom cleaner and rinse with water is recommended. Alternatively, use a luke warm solution of diluted washing up liquid. Do not use household cleaners as they may damage the seals and other toilet parts.

Dry the seal and blade thoroughly and spray economically with silicone spray, alternatively use olive oil. Do not use Vaseline or other vegetable oil products.

The toilet bowl, seat, cover and the exterior of the toilet unit and cassette can be cleaned with a mild detergent/water mixture.



Toilet unit malfunctions

Contact your dealer or a Thetford Service Centre.

We advise draining the fresh water tank prior to travelling. Antifreeze should not be required if the motor home is heated. If you do wish to use antifreeze, brands containing the following properties may be used in the fresh water tank:

- * Ethylene glycol
- * Mono-Ethylene glycol
- * Propane-diol
- * Glycerol
- * Ethane-diol
- * Glycol

Never use alcohol based antifreeze, i.e. Methanol, Ethanol, and Iso-propanol.



TELEVISION & AERIAL

Your vehicle is pre-wired to enable use of a TV with a built-in satellite receiver.

If a TV with a built-in satellite receiver is used, then, at the TV connection point, simply connect the TV signal (digital terrestrial) to the TV connector and the SAT signal to the SAT connector.

There is also a cable input socket, on the outside of the vehicle, with two inputs for connection of external signals. One is for connection of a standalone satellite dish and the other is for a standalone digital aerial or super site aerial supply.

- All Terrestrial TV signals are connected together within the vehicle wiring system and connect to the TV outputs on the TV connection point.
- All Satellite signals are connected together within the vehicle wiring system and connect to the SAT outputs on the TV connection point.
- The roof mounted aerial is for digital terrestrial TV and links to the TV outputs on the TV connection points via an amplifier unit.

See diagram for details of connection.

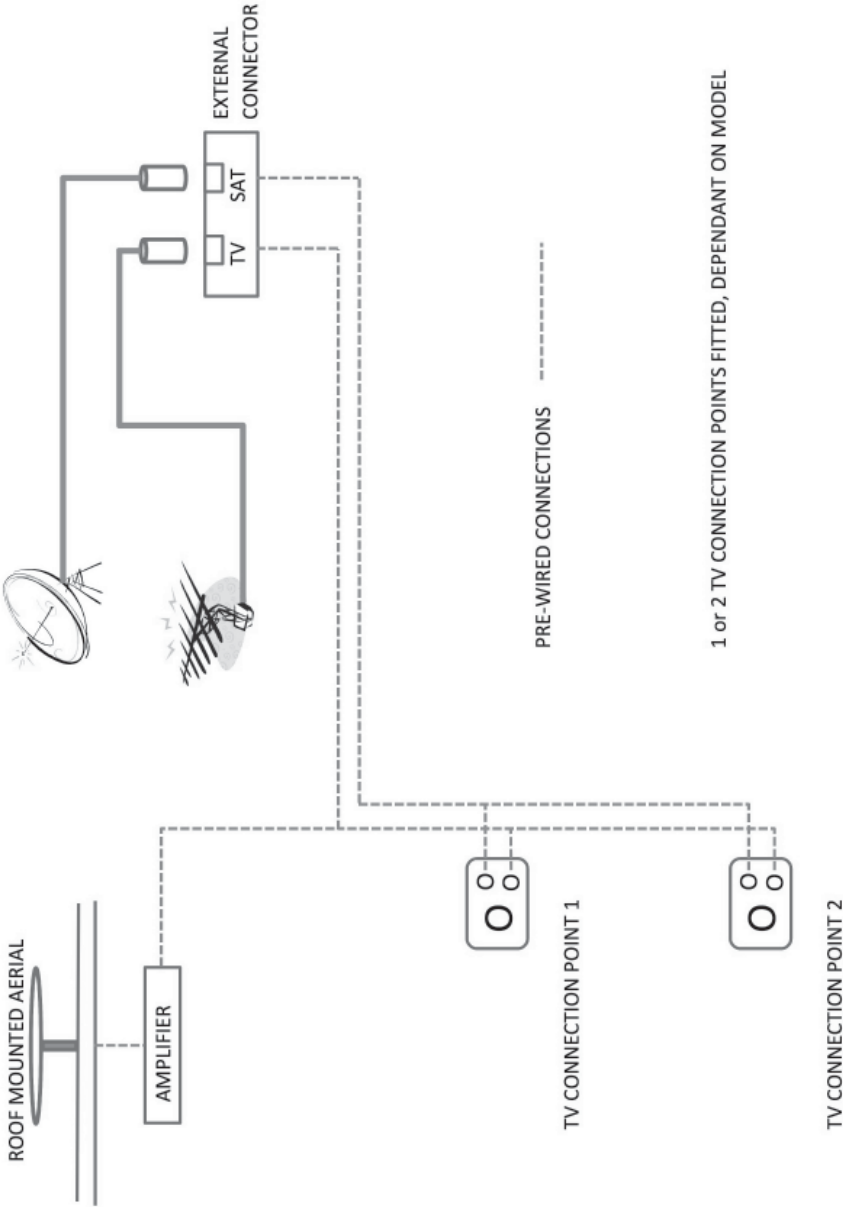

CONNECTION OF TV/SATELLITE SYSTEM



ELECTRIC STEP

An electrically operated rear step is fitted, which is operated by the switch located adjacent to the entrance door.

Note: When extending the step, hold the switch until the step is completely extended. NEVER MOUNT THE STEP IF RETRACTED OR IF NOT FULLY EXTENDED, because then the blocking is not working and the motor can be damaged.

Caution: In the event of the rear step being left extended, a buzzer, positioned behind the dashboard, will sound (when the ignition is switched on) - and the step will self-retract. The step automatically retracts when the ignition is switched on.

Maintenance

Dirt and frost can prevent the step from operating properly. In this case the moving parts should be cleaned or defrosted. All points of movement are layered in maintenance-free bearings.

Consult manufacturers literature for further maintenance details.

REVERSING CAMERA

A wide angle, colour reversing camera is fitted to your vehicle, adjacent to the high mounted rear stop lamp.

The monitor is clipped over the original interior mirror and is automatically activated when reverse gear is selected.

Take care to avoid hard objects from scratching the LCD surface of the screen.

Note that the default setting for the rear camera is to operate only when reverse gear is selected. If required, the mode of operation may be changed so that it functions as a full time rear view mirror. To do this, use the remote control supplied with the monitor and holding it close to the monitor, use the mode selection button to toggle between the two different functions.



AWNING

If specified, your vehicle will be fitted with a Thule Omnistor awning.

General

- An awning is a sun and not a rain protection. The awning should be closed in case of storm, snowfall or heavy rainfall.
- The awning cannot be used without putting out the support legs.
- The fabric should not be rolled up wet for long periods. It should be dried as soon as possible.
- Clean the awning using only water or OMNI CLEANER.

User instructions

- 1) Adjust the crank handle to the required length.
- 2) Insert the crank handle end into the bayonet socket.

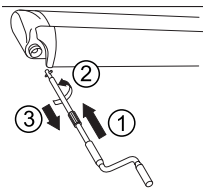
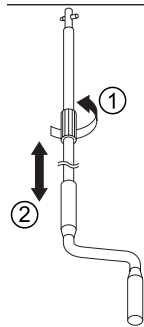

- 3) Turn the crank handle anti-clockwise to unroll the awning while keeping the handle down. Note the awning will only open after a couple of turns.

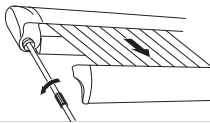

- 4) Unroll a maximum of 1m. Then put out the support legs before unrolling further.

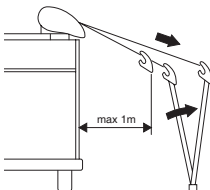

- 5) Slide the support legs out of the front profile.

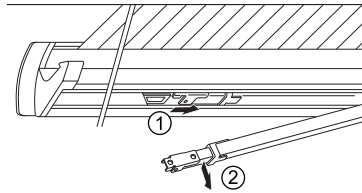

- 6) Adjust the support legs to the required height. The fabric can be tightened by rolling up a little. Note - Never put out the support legs so high that the fabric jams between the arms and the box.

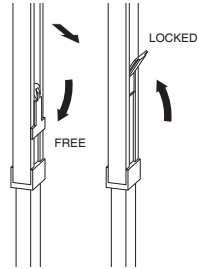

- 7) Fasten the support legs.

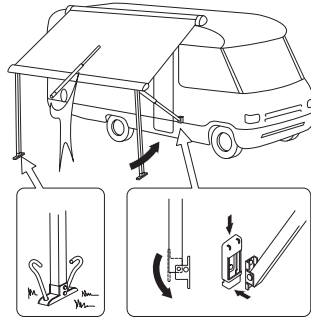

- 8) Install the tension rafter (on larger models).

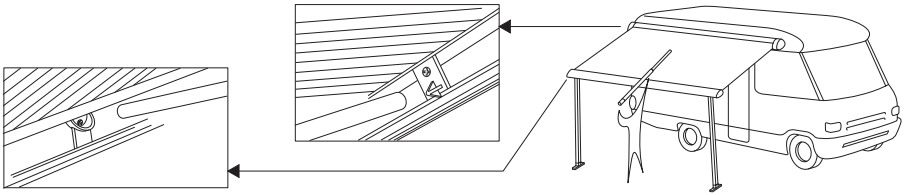

- 9) When raining, lower one side of the awning so that water can run down the fabric. Prevent the fabric from flying up in a sudden gust by using the hold down kit (optional).

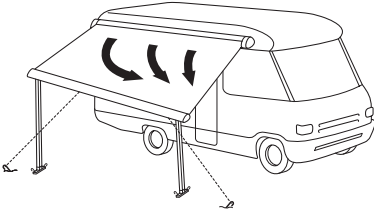

- 10) The front profile locks automatically when the awning is rolled up.

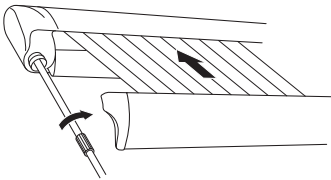

- 11) If you wish to fit leg mounting brackets to the vehicle bodyside, consult your local dealer or the Auto-Sleepers Service Centre.



INTERNAL LAYOUT

General

The Stanton is designed as a two berth model, offering a large transverse double bed, formed without utilizing the front seats.

Cab Seats

Both the reclining cab seats have full forward and rearward movement by releasing the catch on the front of the seat and sliding it to the required position.

The passenger and driver's seats are fitted with a swivel mechanism, which is operated by a lever at the side of the seat.

Ensure that the seats are locked in the forward facing position before travelling.

Accommodation Seating

The Stanton features nearside and offside matching settees. The backrests are held in place with fabric strips, but can be reclined to suit individual requirements.

Please note that Auto Sleepers advises against the retrofitting of lap belts.

Security

Passengers are reminded that it is a legal requirement to wear the seat belts provided whilst the vehicle is in motion.

Table

Two tables are supplied with this vehicle. A large table with folding legs can be positioned between the settees in the lounge area. A smaller table can be used in conjunction with the swivelling passenger seat. The top and leg for this table are stored in the wardrobe, and when required it fits into a socket and bracket on the bulkhead behind the passenger seat.

CAUTION: Ensure that the folding legs are locked in place before using the table. The tables must be stored in the wardrobe when the vehicle is in motion.

Kitchen Area

The kitchen is positioned at the rear of the vehicle and features a Thetford cooker, which has three gas hobs and a single 230V AC electric hotplate. Adjacent to this is a stainless steel sink and drainer concealed by

a glass lid, which may be used as a chopping board. The kitchen area is illuminated by an individually switched LED light mounted underneath the overhead locker. Beneath the sink worktop is a cupboard and four drawers, one of which contains a cutlery tray. All kitchen shelves are coated with a plastic material which is easily cleaned should a spillage occur.

For extra serving space there is a 'worktop extension'. This is positioned below the existing fridge worktop, and slides out on runners.

The Dometic refrigerator is located adjacent to, and forward of, the caravan door. On the left hand side of the fridge unit is a handle to assist entry, a courtesy light to illuminate the stepwell, and the switch for the electric step. Above the fridge is a shelving unit, which also houses the microwave unit. This unit also incorporates two 230 volt sockets for use with mains hook up, a 12 volt socket with TV aerial connection and a USB charging socket.

Above and to the right of the entrance door is the electrical control panel with scrolling menus and programmable control of all the vehicle's electrical services. It incorporates a fresh water level indicator and master switches for the water pump and 12 volt circuits.



ARRANGEMENT OF EQUIPMENT (STANTON)

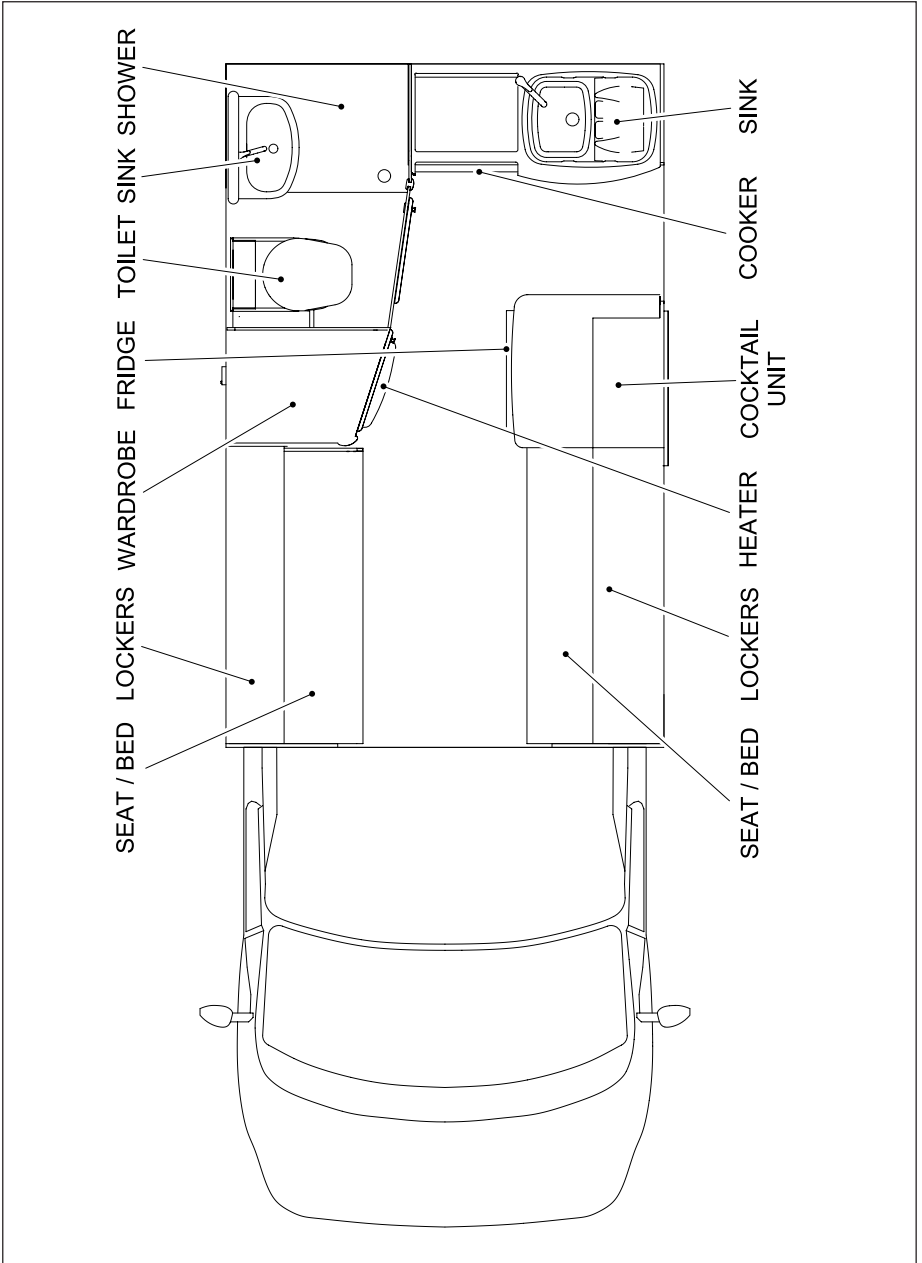



Bathroom

The bathroom is located at the rear offside of the vehicle and features an electric flush toilet, a washbasin with chrome mixer tap and a swing out shower.

The swing out shower features a chrome mixer tap and shower head, and also storage for bottles etc. A plastic shower mat prevents damage to the shower tray when not in use.

Twin fluorescent lights are fitted into the roof along with a five way ventilator, with flyscreen and blind. There is also a blown warm air outlet duct fitted near the floor.

There is also a blown warm air outlet duct fitted near the door.

Wardrobe

The wardrobe, with hanging rail and table storage clips, is situated adjacent to the shower compartment and has a storage drawer fitted below it. In the rear of the hanging space are located the isolation taps for the gas appliances. For explanation of the symbols on each tap, please refer to page 7-7.

Below the drawer in the base of the wardrobe is located the Truma Combi heater, powered by LPG or mains electricity. The rotary controls for this are on the lounge wall side of the wardrobe. The wardrobe also houses the TV aerial mast and signal booster.

The Trumatic space heater, incorporating the mains blown air facility (Ultraheat), is found in the front lower part of the wardrobe compartment.

Lounge Area

The lounge area at the front of the vehicle comprises two inward facing settees, the slatted seats of which can be lifted up to provide access to the under seat storage. (In order to make lifting the seat base easier it is recommended that the backrest is first laid flat against the seat cushion).

Under the offside settee is located the Truma Combi heater, the water pressure adjustment valve and the lockable safe. The water drain valve is accessible through the hole covered with a removable white plastic cap. Access to the electrical control box is via the drop down flap on the front panel.

Lighting throughout the vehicle is provided by fluorescent lights contained in the top of the overhead lockers (which also serve to illuminate the inside of the lockers), and two individually switched fluorescent lights in the roof. Additional lighting in the lounge area is provided by four spotlamps, individually switched, fitted to the underside of the overhead lockers.

One of the nearside overhead lockers contains the storage racks for the crockery, which is supplied separately in its own storage bag.

Storage

Storage is provided by the cupboards, lockers and within the settee bases. Access to the nearside under seat storage is also provided via the lockable exterior hatch door. Additional storage is available in the underfloor exterior locker on the nearside of the vehicle.

Heavy items must not be stored in any overhead locker, nor in any storage area from which they could come free and cause injury to the occupants of the vehicle. Ensure all cupboards are securely fastened before moving off (i.e. that the push buttons are in the 'locked' position).

Ensure any articles stowed below the cab seats will not come loose when the vehicle is being driven.

Habitation Door

Your motorhome is fitted with a Hartal entrance door which is linked to the central locking system. It incorporates a sliding flyscreen, a double glazed window with concertina blind and a waste bin.

Please note the warning against being locked out on page 6-7.



LOCATION OF KEY FACILITIES	
Awning light switch	Bottom lefthand switch on control panel.
Controls for space/water heater	Lounge side of wardrobe
Electric step switch	Bulkhead adjacent to entrance door
Electrical control unit	Behind drop down flap on front panel of offside settee
Electrical isolation switch for space/water heater	On electrical control unit front panel
Fuses, 12V DC	On electrical control unit front panel
Gas isolation taps	Inside wardrobe on right hand wall
Habitation battery	Under passenger seat
Main 12V control panel	Adjacent to entrance door
Main 12V switch for lighting	On control panel
Microwave oven isolation switch	In unit below microwave oven
Miniature Circuit Breakers (MCBs)	On electrical control unit front panel
Radio rear speakers	Below rear overhead lockers
Reading lights	Below overhead lockers, all individually switched
Residual Current Device (RCD)	On electrical control unit front panel
Safe	Rear of kitchen unit cupboard
TV connection point	One on lounge side of cocktail unit One under front nearside overhead locker
USB charging socket	One on lounge side of cocktail unit
Water heater safety/drain valve	Under offside settee
Water pump / filter	In freshwater tank
Water pressure adjustment valve	Under offside settee
Water tank heater switch	On control panel
Waste tank heater isolation switch	Below offside sofa
230V AC sockets	Two in corner of kitchen above sink Two on lounge side of cocktail unit One on front panel of offside settee One on front panel of nearside settee One on exterior bodyside



SLEEPING ARRANGEMENTS

STANTON

Transverse double bed

Slide out both seat bases until they meet in the centre of the aisle. Use the backrest cushions to infill the remaining areas. The backrests will now lie flat and fill the space between the base cushion and the side of the vehicle.

Single bed

Pull the seat base forward sufficiently to allow the backrests to drop vertically in behind it. Rotate the front seat through 180° to face the rear and align it with the settee. (On the driver's side it may be necessary to lower the handbrake before rotating the seat, see note on page 4-2).



NORMAL SEATING ASSEMBLY

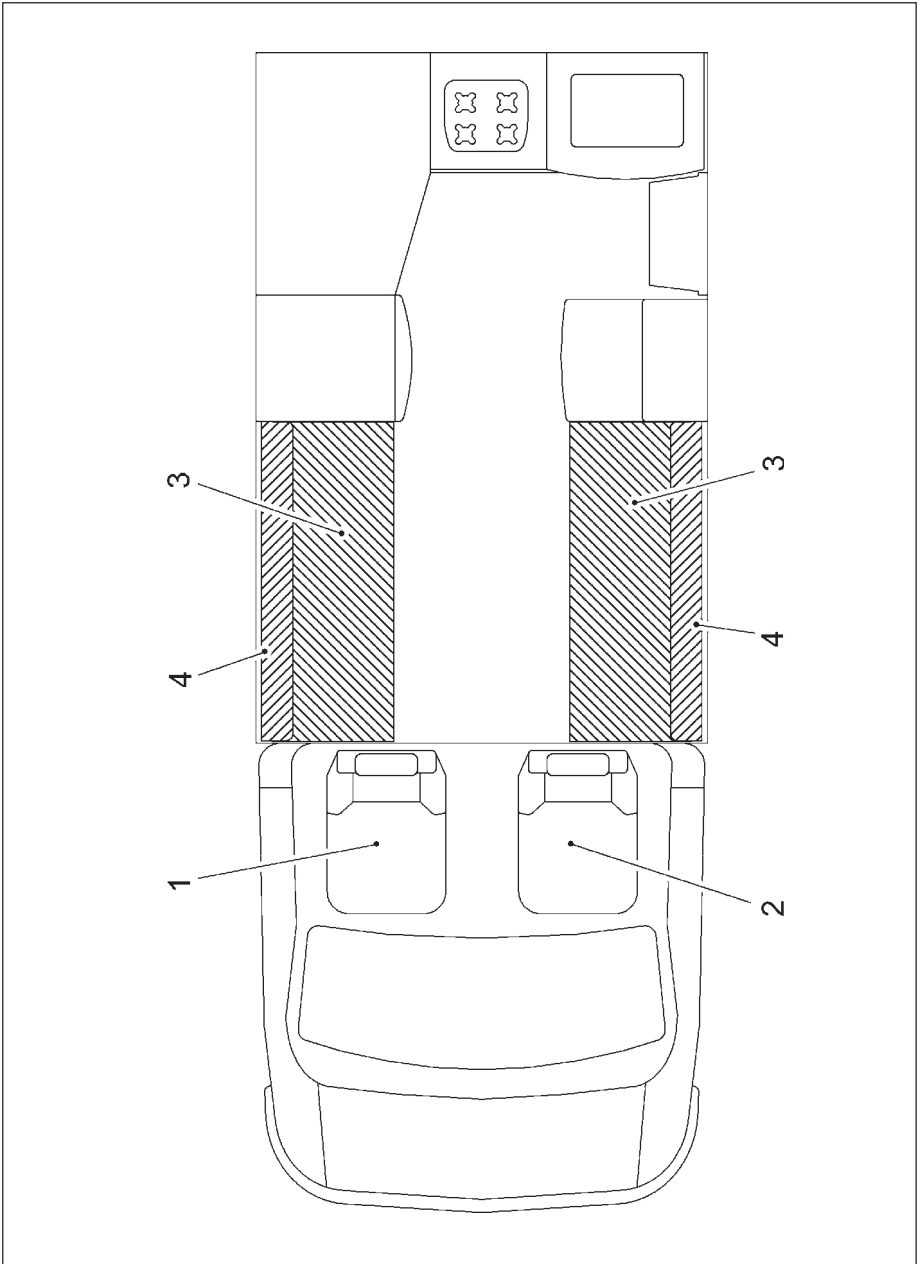



SINGLE BED ASSEMBLY

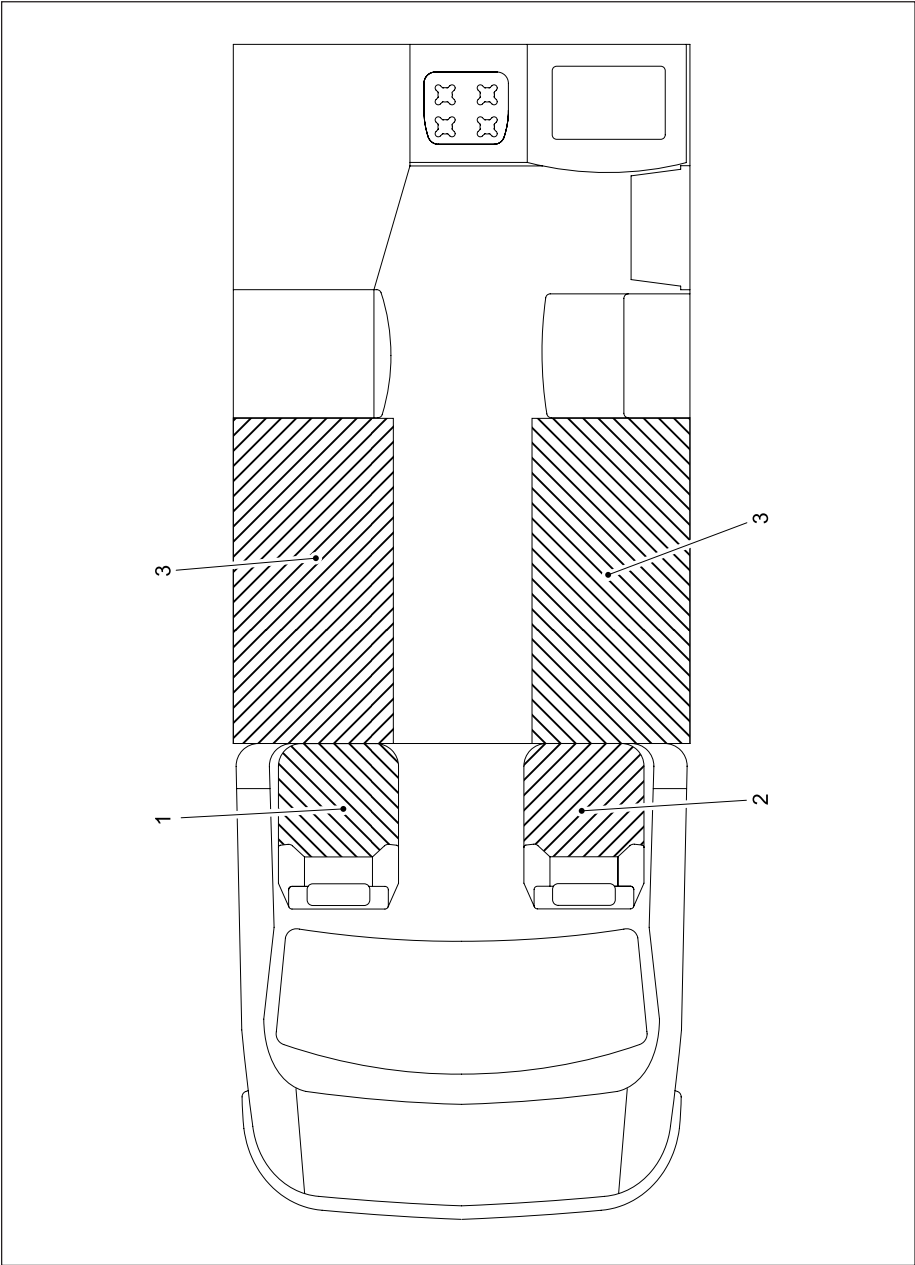



DOUBLE BED ASSEMBLY

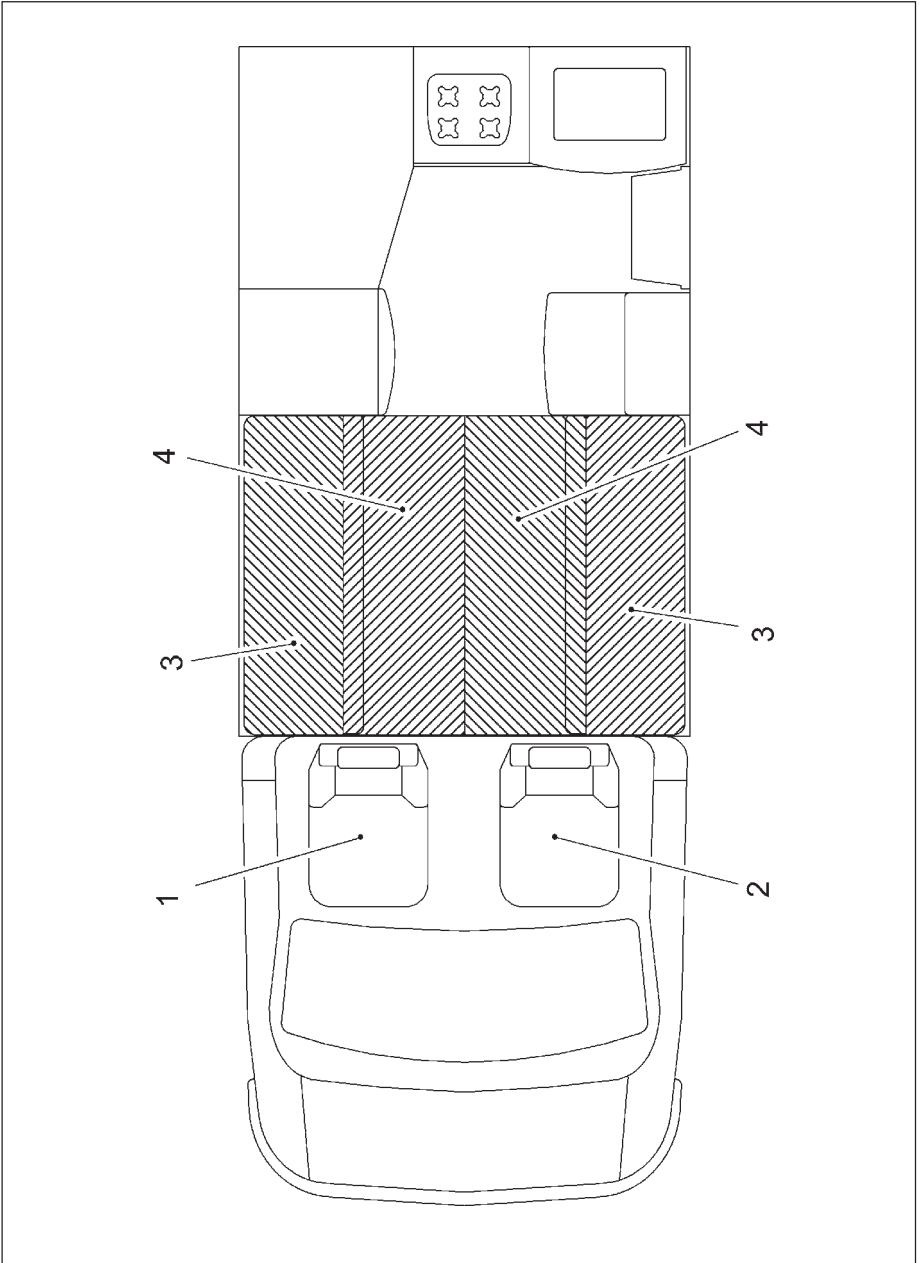



PARTS LIST (STANTON)

Item	Part No	Description/Cushion type	Qty	Notes
1	CS0161	CAB SEAT RH	1	-
2	CS0161	CAB SEAT LH	1	-
3	CS0304	BENCH SEAT BASE CUSHION	2	-
4	CS0304	BENCH SEAT BACK REST	2	-



EQUIPMENT ARRANGEMENT

Windows and Ventilation

Double glazed acrylic windows are fitted as standard to all lower caravan windows. These top hinged windows allow excellent ventilation and are secured by locking over centre catches. They may be kept open in a variety of positions by use of the ratchet. To unlock the catch, depress the button in the centre of the handle stays and turn.

The top hinged acrylic windows must be locked closed, or in their intermediate travelling position, whilst the vehicle is in motion.

Ventilation

Your vehicle is fitted with a large Remis roof light above the lounge area, and a Seitz Skyview is fitted above the cab. The window in the roof mounted air conditioning unit provides extra light in the kitchen area.

When the vehicle is being driven the roof ventilators should be fully closed. Wind noise may be reduced by closing the night blind.

WARNING: The roof ventilators are designed to flow a certain amount of air even when fully closed. Do not obstruct them - your safety depends on them.

Remis Roof Light

The Remis roof lights incorporate a separate sliding flyscreen and night blind which can operate even if the ventilator is open. To open the large roof light, release the handle and wind until the required position is reached. To open the smaller roof light, release the catch and push upwards until one of the holding positions is reached.

Seitz Roof Light

The Seitz roof light is operated by a rotating handle, which means it can be opened to any required position. It incorporates a separate sliding flyscreen and night blind which can operate even if the ventilator is open.

Climate Control

If specified, your vehicle will be fitted with a Truma Aventa Comfort air conditioning unit in the roof of the habitation area. This will

supply fresh and dehumidified air in summer and warm air in winter. The unit can be set, using the digital Truma control panel or a handheld remote control unit, to operate in conjunction with the Combi heater to maintain any required room temperature. It is also possible to set timers for automatic switching on and off, and there is a sleep function for quiet cooling. For full operating details please read carefully the instructions supplied with the vehicle.

Insulation

Your vehicle is insulated largely in polyurethane, a material with high insulation qualities. This is used in the construction of the floor, body sides, rear panel and ceiling, and contributes greatly to the insulation qualities.

Stainless Steel Sink and Drainer

The stainless steel sink and drainer should only be cleaned with light detergent. Under no circumstances should bleach be used since this will react adversely with the stainless steel and may cause small holes in the metal.

Extra Work Surface

Extra work surface is provided by a slide out flap below the kitchen worktop, which is retained in its stowed position by an internal catch.

It is not recommended to travel with this worktop extended, nor of course, with anything on it.

Habitation Battery

The battery is a 100AH 12V, low maintenance, leisure battery which should only require attention at the annual habitation service.

If a replacement habitation battery should be required then it is important that the replacement be of the same type and specification as that originally fitted.

WARNING: Switch off all appliances and lamps before connecting or disconnecting the habitation battery.

SMOKING PROHIBITED



Electronic Control System/Battery Charger

A Sargent EC500 Power Control System is fitted to your vehicle. It features a built in intelligent 'offline' battery charger, a system monitoring circuit and a digital control panel with scrolling menus. For a full description of this unit including operating instructions and fault finding, refer to the Connection of Services section.

Electrical - General

The 230V AC sockets fitted to your vehicle are suitable only for medium demand components such as televisions and hairdryers. Safety/overload protection is provided by the MCBs located under the cover on the front of the electrical control box.

An electrical interface adaptor box is located on the bulkhead behind the driver's seat. This contains fuses and relays for systems connected directly to the base vehicle electrical system and these are unlikely to require attention from the owner.

At least one 12V socket and one 5V USB charging socket are provided with your vehicle. For their locations, please refer to the Location of Key Facilities Chart.

The mains hook up cable, provided as standard, is stowed beneath the offside settee.

Retrofit Options

Contact either your local Auto-Sleeper dealer or the Motorhome Service Centre, Willersey for further details.



GENERAL

In order to keep your Auto-Sleeper in first class condition, periodic maintenance will be required to both the bodywork, windows, upholstery and other parts of the conversion. This maintenance should be carried out as follows:

Servicing

Servicing of the conversion is the responsibility of your local franchised Auto-Sleeper dealer to whom all queries should be referred. Your local base vehicle commercial dealer should carry out servicing of the base vehicle.

GLASSFIBRE BODYWORK AND ACRYLIC WINDOWS

General Cleaning

At regular intervals, you should wash the fibreglass bodywork with a recognised cleaner for use on fibreglass gel coats. A car shampoo without wax is recommended. Should marks remain, use a cleaner with chemical and abrasion agents formulated for use on gel coats.

Discolouration

Fading or discolouration of the gel coat is a natural ageing process caused by ultraviolet light. To overcome this, use a mild abrasive, which removes a thin layer of the discoloured surface. This will restore the bodywork to its original colour and surface lustre. Since discolouration develops gradually, it should not be necessary to carry out this procedure more than every three years. Frequent use of abrasive materials can reduce the thickness of the gel coat, to a potentially harmful extent.

Removing Scratches from Bodywork

Scratches can be removed from both gel and painted surfaces. The method depends upon the depth of the scratch, as care has to be taken to avoid penetrating the paint or gel coat. Very fine, hairline scratches can be removed by rubbing across the line of the scratch with rubbing compound. Slightly deeper scratches should be lightly wet sanded first using very fine (2000 grit or finer)

abrasive paper. Rubbing compound will then remove the flattening marks created by the abrasive paper. For deep gouge type scratches, where the paint or gel may have been penetrated, you should first seek the advice of your supplying Auto-Sleeper dealer.

Cleaning Interior Plastics

Interior plastic parts, such as the shower and wash basin, should only be cleaned with warm soapy water, or non-abrasive cleaners specified as being suitable for use on plastic items.

Removing Scratches from Acrylic Windows

All windows, except the chassis cab and Luton, are manufactured in acrylic. Over time these become scratched and their clarity impaired. An Acrylic Window Polish removes unwanted scratches and blemishes leaving a clear, haze free finish. Minor scratches can be polished out directly.

Recommended Materials

G3 Paste Compound: This is a cutting compound and polish, recommended for use on painted surfaces and GRP. It is ideal for removing the traffic film that builds up on glassfibre coachwork and not only restores it to its former glory, but adds a high level of polish as well.

G10 Extra Fine Grade Liquid: This is again ideal for polishing surfaces and removes swirl marks and very fine scratches. It is less abrasive than G3 yet has the same polish properties and cleans and restores discoloured surfaces. It is ideal for use on dark colours. Can also be used to polish out scratches on plastic windows.

Finishing Cloths: These are very fine grade cloths, woven and thus easily washable that are recommended by Farecia for use with their materials.

The above can be purchased from our Service Centre, Willersey (01386) 853511.



UPHOLSTERY MAINTENANCE

Cleaning

Upholstery should be brushed or vacuumed regularly. Fabrics should be wiped every six to eight weeks with a lint free cloth and fabric cleaning fluid. Velour materials may be dry-cleaned.

Fabric Care

Fabric snags caused by sharp objects such as toys, nails, etc., should be trimmed off immediately. Never attempt to pull them off since this could cause the snag to run.

Whenever possible, avoid exposing the upholstery to direct sunlight which might eventually cause the colour to fade.

Fabrics with a velour type pile finish will develop crush marks in use - this is unavoidable and does not affect the quality of the product in any way.

Stain Removal

A proprietary dry cleaning fluid will remove most household stains. However, stubborn stains, such as coffee, wine or ice-cream may need pre-treatment with a mild soap and distilled water.

Small marks in velour type fabrics can usually be removed by stroking along the pile using a small brush and warm water.

We strongly recommend that before commencing any treatment an inconspicuous piece of material is tested for colourfastness and shrinkage. If in doubt, please contact a professional dry cleaning company. Do not apply cleaning solvents to velour piping, otherwise the flock will be removed.

Work Surfaces

Whilst these are hard wearing, hot pans should not be placed directly on these surfaces, since damage may result.

STAINLESS STEEL COMPONENTS

Internal

Do not clean stainless steel fittings, i.e. splash plate and sinks with bleach since this reacts with the stainless steel and may lead to corrosion.

GAS INSTALLATION

All gas vents and flue pipes should be periodically checked for damage and should be kept free from dirt.

Blocking of vents or flues is extremely hazardous and should be avoided at all times.

Gas Appliance Igniters

It is advisable, periodically, to check visually the igniters on hobs, grills and ovens are sparking correctly.

Annual Inspection

The gas installations should be inspected annually by qualified personnel. If in doubt contact your supplying Auto-Sleeper dealer. Modifications to the gas systems should not take place unless carried out by qualified technicians.

SEAT RESTRAINTS

WARNING: In the event of any impact of 25 mph or over in which seat belts have been worn, they must be replaced before the vehicle is used again.



WATER SYSTEM

Fresh Water Tank

At regular intervals, and at least every three months, the fresh water system should be flushed through with fresh water. Furthermore it is advisable that prior to using your Auto-Sleeper, the fresh water system is thoroughly flushed with fresh water.

Waste Water Tank

Since the waste water tank can hold foreign matter, it should be regularly flushed with fresh water. To prevent odours working back through the shower and sink outlets, flush the waste tank through with a small amount of mild disinfectant.

Depending on the use of the waste tank, it is possible that this will collect solid waste matter, which in some instances may build up and block the waste tank outlet tap. In this case it will be necessary to drop the tank for cleaning. Access is through a large diameter fitting in the tank top. Once removed this will allow the tank to be flushed out in an inverted position and all solids removed.

WINTERISATION

General

This section contains information on the winterisation of your Auto-Sleeper, particularly when you may wish to lay up your vehicle for the winter months.

Water System

The water system should be fully emptied, by opening the drain valve located adjacent to the water heater (see heater section for more details), and the drain taps on both the fresh water tank and waste water tank left in the open position. Likewise, all internal taps should be left open and the water pump run until the last traces of water have come out of the taps. Take the vehicle for a short drive, with all the drain taps open, in order to remove the last drops of water from the tanks and water system. Remove all sink plugs to allow the water system to breathe.

Flush fully the waste water tank to remove any excess debris and waste material. Flush through again with disinfectant as part of the final drain. Leave drain tap open.

Upholstery

We advise that any detachable upholstery is removed and taken indoors during prolonged winter storage, particularly detachable upper bed mattresses and scatter cushions.

Curtains/Blinds

To prevent uneven bleaching, and possible excess sunlight onto the furniture and fabrics, we recommend that either the curtains or blinds are left drawn.

Refrigerator

Leave the refrigerator door open, on its intermediate lock position; this will allow the refrigerator to breathe and prevent any unpleasant odours in the storage department.



Ventilation

There is fixed upper and lower ventilation in your Auto-Sleeper which is built-in in the interests of safety. There is therefore no need to leave any windows or roof ventilators ajar - indeed the roof ventilators have sufficient fixed ventilation to allow the interior of the vehicle to breathe satisfactorily.

Exterior

Fit, where appropriate, winter covers to the fridge ventilator grilles. Give your Auto-Sleeper a good wash and polish before laying up, and apply a small film of protective oil to the stainless steel roof rack, ladder and any other external polished metal components.

Electrical

Turn the electrical system off using the 'Shutdown Switch' on the front of the control box (see diagram & 'Activating the System' in section 7). This turns off all the leisure electronics apart from any alarm and tracker power feeds.

Mercedes recommend that if the vehicle is to be parked up for a long period that the vehicle electrical system is switched off at the battery isolating switch. For full instructions on the procedure, refer to the Mercedes hand book supplied with the vehicle and look in the index at the front of the book for the section entitled 'Battery/Isolating switch'. If this advice is followed, bear in mind that the remote central locking will not function, although it will still be possible to unlock and lock the doors manually using the key.

To maintain the vehicle battery in good condition it is recommended that it is fully charged prior to storage and then recharged every 3 months. For full instructions, refer to the Mercedes hand book and look in the index for the section entitled 'Battery/Charging'

Windows

Open all windows fully. Check all window seals are intact and shut firmly. Ensure locks and over centre catches are applied as appropriate.

Automotive

Follow the advice laid down by the base vehicle manufacturer. In particular,

- Secure the vehicle using chocks. Release the handbrake to prevent the brake linings from seizing on.
- Increase the tyre pressure (by approximately 2 bar above the standard pressure) to prevent the tyres from becoming flat.

WARNING: Do not exceed the maximum pressure noted on the sidewall of the tyre.

Alternatively, jack up the vehicle to relieve the load on the tyres.

- Cover the tyres to protect from sunlight, as they will deteriorate rapidly in ultra-violet light. A light proof cover will help to prevent cracking of sidewalls and premature ageing.
- Check coolant for antifreeze protection, correct as required.
- Check windscreen and headlamp cleaning systems for antifreeze protection, correct as required.



TROUBLESHOOTING

The following are a series of fault finding charts to which you should refer in the event of problems you may have regarding 230/12V, LPG and water. This should be used as a guide only, and in the case of an electrical fault, where a fuse has blown or an MCB tripped out, the fault must be located before replacing the fuse. If a fault is suspected with the LPG system, consult a GAS SAFE registered technician.

If in doubt consult a qualified technician or your local Auto-Sleeper dealer.

12V TROUBLESHOOTING CHART

Symptom	Cause	Remedy
Habitation 12V does not operate	Main 20A fuse blown	Check/Replace
	Battery Discharged	Recharge
	Switch on control panel in off position	Switch to on
	Vehicle ignition 'on'	Switch 'off' ignition
Habitation battery not charging	Main 20A fuse blown	Check/Replace
	Relay fault	Refer to dealer
	Contacts dirty/loose on battery terminals	Clean and check for tightness
	Poor earthing	Check earthing to chassis point
Battery does not hold its charge	Failed battery	Electrically test and replace if necessary
	Current being drawn	Check all appliances are off when not in use
Battery discharges over a short time with appliances operating	Poor battery cell condition	Electrically test battery
	Failed battery	Change battery
	Battery not fully charged	Fully recharge battery
No power to one or more 12V appliances	Circuit fuse blown	Find fault and replace fuse with same rating
Water pump not operating	Switch on panel 'off'	Switch it 'on'
	Pressure switch on pump not operating	Refer to dealer
	Fuse 4 blown	Find fault and replace fuse with same rating
No power on 12V socket outlet	Fuse 9 blown	Find fault and replace fuse with same rating
	12V plug incorrectly connected/wired	Check plug

**12V TROUBLESHOOTING CHART (continued)**

Symptom	Cause	Remedy
Heater not operating/cuts out	Fuse 8 blown	Find fault and replace fuse with same rating
	Low battery charge	Recharge battery
	Unit fault	Refer to dealer
Cooker ignition not operating	Fuse 2 blown	Find fault and replace fuse with same rating
	Spark unit fault	Refer to dealer
	Fault on cooker unit	Refer to dealer
Fridge gas ignition not operating	Fuse 2 blown	Find fault and replace fuse with same rating
	Ignition control switch fault	Refer to dealer
Fridge does not operate on 12V when engine is running	Fuse 6 in EM45 interface box blown	Find fault and replace fuse with same rating
	Fault on fridge relay	Refer to dealer
	Fault on fridge unit	Refer to dealer

230V TROUBLESHOOTING CHART

Symptom	Cause	Remedy
230V system inoperative	No site power	Check site supply
	RCD/MCB switches tripped out	Reset circuit breakers
RCD/MCB keeps tripping out	Fault on 230V supply	Check supply including polarity
	Faulty appliance	Turn off all appliances, reset circuit breakers, turn on appliances until fault occurs. Isolate faulty appliance
	Overload on current consumption by appliance	10A maximum available do not use appliance
Heater not operating/cuts out	No power	Leave to cool down
	Overtemperature trip activated	Reset thermal cut-out (refer to operating instructions)
Cooker Hotplate not heating up	No power	Check MCB is on

**LPG TROUBLESHOOTING CHART**

Symptom	Cause	Remedy
Appliance will not light	No gas	Check isolation tap is open
	Low battery (auto ignition)	Charge battery
Appliance lights but goes out immediately the FSD override is released	Flame supervision device (FSD) is not functioning correctly	Refer to dealer
Odour	Gas leak	Turn off the gas at the isolation tap and do not use the gas system until the problem has been rectified
		In the event of a leaking cylinder, contact the site warden and/or the local gas supplier
Yellow flame	Lack of primary air. please note yellow tipping to the flame is normal	Refer to dealer
Orange flame	Particles of dust or dirt in the mixing tube being carried through the burner ports	Reduce the amount of dust in air
	Burner ports partially blocked	Refer to dealer
Floating flame	Lack of secondary air	Check all vents are clear (air inlet to vehicle)
	Blocked retention ports	Check retention ports are clear
	If in an oven	Check the flue way is clear



WATER TROUBLESHOOTING CHART

Note: For more help with water pump issues, please refer to page 7-1 of this handbook.

Symptom	Cause	Remedy
Continuous running of water pump	No water	Fill tank
	Major leak	Switch off immediately and check system
	Pressure not set correctly	Adjust as page 7-3
Intermittent operation of water pump	Minor leak in water system	Check push fit joints
Water pump does not operate	Fuse 4 blown	Find fault and replace fuse with same rating
Water gauge does not operate	Probe fault	Refer to dealer (check probe connections)
No hot water (230V system)	No power	Switch on isolator switch/check MCB is on
	Overtemperature trip activated	Leave to cool down
No hot water (diesel system)	Heater module not lighting	Refer to dealer
	Igniter not working	Check 12V switched on
Slow drainage from sink/shower tray	Blocked breathers in waste tank	Drop tank and clear breathers
Unsatisfactory operation of water pump	Filter blocked	Refer to dealer



DATA RECORD

We suggest that you record key details in the spaces below should you accidentally mislay your keys or other vital documentation.

Vehicle Type

Vehicle Model

Auto-Sleepers Production Number

Keys

Ignition Key

Door Key (if applicable)

Fuel Filler (if applicable)

Water Filler

Gas Compartment Key

Toilet Compartment Key

Alarm Code (if fitted)

AA/RAC/etc. Membership Number

Radio Security Code

Supplying Dealer Contact Number



AUTO-SLEEPER DEALERS

To find your nearest Auto-Sleepers dealer please go to www.auto-sleepers.co.uk and click on 'Find a Dealer'.



RECOMMENDED ANNUAL SERVICE CHECK FOR MOTOR CARAVAN BODIES AND CONVERSIONS

It is recommended that the annual service is carried out by an approved motorhome service centre.

Introduction

This entire section offers guidelines for the checking of a motorhome's habitation area and to ensure continual compliance with EN1646-1.

It does not cover any part of the base vehicle, although there may be minor overlapping (such as tyre pressures, cab seats, internal lights, battery and windows) in a van conversion. The base vehicle must be serviced in accordance with the chassis manufacturer's instructions.

Reference should also be made to:

- Any owner's manual or equivalent supplied with the vehicle by the motorhome converter.
- Appliance manufacturer's instructions.
- Driver's handbook or equivalent supplied by the chassis manufacturer.
- A vehicle is accepted for service at the dealer's discretion.
- Any defects, repairs, adjustments, cleaning or lubrication required will be noted on the checklist. The customer's approval will be obtained before any work is done.

Not all of the equipment mentioned in this manual is fitted as standard to every motorhome.

This guide is published as an aide memoire for dealers. Any work carried out following the check, and the sufficiency of the work in the check itself, is subject to the contract between the customer and the dealer.

SECTION 1 - BODY MOUNTING

Body to Chassis

Examine all fixings retaining the body to the chassis - this may be direct or through a sub-frame. Where practical, all fittings should be checked to ensure they are all present and correctly secured.

Body to Cab

Examine joint between body and cab for signs of movement and soundness of sealing media.

Body Retention (dismountables)

Check serviceability and tightness of body retaining gear.

Check serviceability of body support struts and mountings. (Note: whether it will be necessary to demount the body to check the body supports must be agreed between dealer and customer).

SECTION 2 - WINDOWS

Windows

Check window glazing rubber or sealing for cracks and general condition. Check for satisfactory operation and closing.

Check fixing of top hinge rail on top hung windows.

Check for good weather seal when window is closed and latched.

Check catches and stays for satisfactory operation.

SECTION 3 - DOORS

EXTERNAL DOORS

Not including base vehicle doors.

Security:

- Check that hinges and catches are satisfactory and that, when latched, doors are held securely shut.
- Check that the keys or internal latches lock the doors correctly.
- Check that any device fitted to hold a door in the open position is satisfactory.



Sealing:

- Check all door seals for cracking and general condition.
- Check correct closing to give a weather-tight seal.

Childproof Lock:

- Where a door is fitted with a childproof lock check that an appropriate warning notice is fixed adjacent to the door. Appropriate warning notices are available from motorhome manufacturers.

INTERNAL DOORS

Security:

- Check that hinges and catches are satisfactory and that, when latched, the door is held securely shut.

Safety:

- Check that any device fitted to hold a door in the closed position can be operated from both sides to open the door in an emergency.

SECTION 4 - ATTACHMENTS TO CHASSIS OR UNDERBODY

Corner Steadies

Check that attachments to chassis are secure.

Ensure steadies work freely and satisfactorily.

Lubricate screw to ensure correct operation.

Folding/Retractable Steps

Check that step pivots are satisfactory and not worn. Check that, when closed, the retaining mechanism holds the step securely. If fitted, check device is working.

Underfloor Water Tank Mountings

Check mounting frames are secure to body. Any fastenings that require releasing to remove the tank should be free of rust and operate freely. (Removal, flushing, cleaning and replacing of tanks will be carried out at the prior request of the customer or will be done subsequently with other work).

Spare Wheel

Remove spare wheel. Check for damage. Check tyre pressure.

Check mounting frame for security to body and for secure retention of spare wheel.

Wheel Boxes

Check for damage, corrosion, water seepage, signs of tyre scrubbing.

SECTION 5 - ATTACHMENTS TO BODY EXTERIOR

Roof Lights

Check security, general condition, and that sealing has not deteriorated.

Roof Racks and Ladders

Check security to body and general condition.

Check roof for damage adjacent to rack.

Mouldings, Trims

Check security. Check sealing has not deteriorated.

Flue Terminals, Air Vents

Check security. Check sealing has not deteriorated.

Check that these are not blocked.

SECTION 6 - INTERNAL

Body Seepage Check

Examine for moisture/water staining of areas under windows, at side of roof and at corners, which could indicate water seepage problems. A moisture meter should be used where appropriate.

Furniture

Check furniture is securely fixed.

Check door hinges, catches and stays for satisfactory operation.

Dinette Seats/Beds

Check seat bases for security of fixings and for damage.

Make up beds according to manufacturer's instructions and check for rigidity and safety.



Upper Bunks

Check there is a secure means of access to upper bunks and that, where applicable, protection against falling out and entrapment is provided.

Curtains/Blinds/Nets

Check track is secure and curtains draw freely without snagging.

Check blinds and/or nets for correct operation.

Check flyscreens in roof lights and air vents.

Cab Seats

Where cab seats form part of the living area and/or bed layout they should be checked for security of attachment, smooth and easy operation of seat slides, swivels and seat back operation.

Fire Extinguisher

Check condition and expiry date. If an extinguisher is not fitted, inform the customer of the advisability of such equipment

Fire Blanket

Check position (should be near cooker).

If one is not present, inform the customer of the advisability of such equipment.

Advice to Occupiers/Warning Notice

Check presence and condition and advise customers accordingly.

The wording and layout of the notice should be set out as follows:

ADVICE TO USERS

VENTILATION

Do not obstruct the ventilators which are fitted; your safety depends on them.

IN CASE OF FIRE

1. Get everyone out.
2. Turn off outside gas valve and/or oil valve (if fitted).
3. Disconnect the mains electricity supply.
4. Raise the alarm and call the fire brigade.
5. Tackle fire if safe to do so.

FIRE PRECAUTIONS

Children: Do not leave them alone.

Means of Escape: Make sure you know the location and operation of the emergency exits, keep all escape routes clear.

Combustible Materials: Keep them clear of all heating and cooking appliances.

Fire Fighting: Provide, at least, a 1kg power fire extinguisher, that complies with BS5423 by the main exit door, and a fire blanket next to the cooker. Make yourself familiar with the instructions on your fire extinguisher and the fire precaution arrangements on the caravan park.

Portable or Open Flame Heating Equipment

Check for its presence. The customer must be advised against its use.



SECTION 7 - ELEVATING ROOFS

Lifting mechanism

Gas struts or spring struts should be checked for corrosion (particularly on the piston rods of gas struts), smooth operation when operating roof up and down and to ensure that they support the roof when fully up.

Check attachment points of struts to body and roof.

Canvas side walls

Check for satisfactory attachment to body and roof.

Check for splits or holes, particularly at fold lines.

Check that the canvas stows satisfactorily when roof is lowered. (A waterproofing check will be done at the request of the customer).

Solid Side Wall

Check sides and end panels fold up and down correctly, that they seal against each other where appropriate and that retaining mechanisms are satisfactory.

Check all hinges for security and freedom from strain.

Locking of Roof

It is important to ensure that, when the roof is in the travelling position, it is safely and positively locked down. Any locking retaining mechanism should be carefully examined.

SECTION 8 - GAS SYSTEMS

Cylinders, Regulators and Feed Hoses

Establish that the cylinder and feed hose is compatible.

Since the introduction of BS EN1949 the gas pressures for Butane (blue) cylinders and propane (red) cylinders have been harmonised across Europe. The gas system pressure is now 30mbar for both gases.

The gas regulator is now fitted as standard equipment by Auto-Sleepers. Your supplying dealer will need to supply you with the correct hose compatible with the cylinder to be fitted.

Check cylinder compartment vents and gas drop hole in floor are free from obstruction.

Check seals on internal doors.

Hose and Piping

Check any flexible hose is of an approved type. Check its condition and any evidence of cracking.

The maximum permissible hose length is 400mm, longer hoses should not be used. The hose length is the length of the flexible portion of the hose assembly. Do not use external cylinders and or extension hoses.

Check piping for condition, damage and correct support.

Carry out an overall leak test.

Appliances

In general, the checking of gas appliances can be divided into the following:

1. Cleaning.
2. Operation of controls.
3. Correct flame structure.
4. Flues.
5. Flame failure device.
6. Security.

Cleaning

- Where appropriate, remove cover(s) to gain access to heat exchanger. Clean away any fluff or foreign matter. Reassemble and test. Clean flame viewing window.



Controls

- Check that all knobs etc. work smoothly and are secure on their spindles. If gas taps require greasing to ease stiffness, use only approved LPG grease. Check that appliances can be brought into service using the normal controls.

Correct Flame Structure

- Check that all pilot flames burn quietly and clearly.

Refrigerator: With the refrigerator gas control turned to maximum, the colour of the flame should be predominantly blue.

Instantaneous Water Heating: The main burner flame should be of even height and blue in colour. A flame burning yellow will allow sooting to occur.

Ovens: The oven flame should burn quietly and be of even height, mainly blue/green in colour. If the gas is propane, the flame will normally develop yellow tips as the burner heats up. If the gas is butane, a small amount of yellow tipping will be seen immediately after lighting, increasing as the burner heats up.

Grill Burners: It is normal for the flames on this type of burner to develop yellow tips as it heats up, particularly on butane.

General: A flame lifting away from the burners is an indication of too high a pressure, although it may happen with grill burners whilst the frets are heating up. A yellow flame will cause sooting and is an indication of too low a pressure. Providing the regulator and piping have been checked and found satisfactory, the above faults should not appear.

Flues:

- Flues should be examined for security of fixing and for correct attachment to appliances and flue terminals. They should be free from damage and corrosion. Check for leakage of flue gases into the vehicle.

Flame Failure Device (FFD):

- Where fitted, FFD should be checked to ensure satisfactory operation. After the

appliance has been successfully checked, allow time for the thermocouple to cool. Attempt to relight the appliance by turning it on without pushing in the gas control knob. (Do not override the FFD). If appliance does not light, FFD is satisfactory.

Security:

- Check appliance is securely fixed to the vehicle/furniture and will be free from rattles. Where applicable, check that water pipes are satisfactorily attached with no sign of leakage.

Protection of adjacent surfaces:

- Check that surfaces adjacent to open flame cooking appliance have adequate protection.

Inspections:

- It is recommended that inspections are carried out by a qualified fitter trained to, for example, GAS SAFE or Calor standards.



SECTION 9 - WATER SYSTEM

Before operating the water system, a visual check of the following items may show up an obvious leak source...

Fresh Water Tank

Check condition, fill tank and check for leaks.
Check the external filler and filler pipe to tank.
Check for satisfactory venting.
Check condition and presence of filler cap.

Waste Water Tank

Check drain tap is clear and working.
Check condition and presence of drain hose.
(The water tank will be drained, flushed, cleaned and charged with a measure of toilet fluid/disinfectant at the prior request of the customer).

Pump Filter

When applicable, remove filter and replace.
Check the in-line pump for security and condition. Remove the submersible pump from tank, check condition.
Check pump inlet and outlet are clear and not obstructed.
Check delivery hose and electric cable are secure and satisfactory.

System Check

Operate pump. Check all piping for leaks.
Operate taps and shower. If a hot water system is fitted, it can be checked for leaks etc., using cold water. (Note: Aerated water from tap could be due to a leak on the suction side of the pump).

Waste Water System

With water running through the drain pipes, check for leaks and satisfactory draining of water from sinks etc.

Couplings and Fluids

Check that the appropriate markings are used - blue for fresh water, grey for waste water. Ensure a sealing off cover is supplied for each coupling.
Check that filler positions are designated "petrol", "diesel" or "water" as appropriate.

Toilet Waste Tank

Check that any fixed tank intended to receive discharge from a toilet is fitted with either a level or full indicator.

SECTION 10 - ELECTRICAL SYSTEMS

Extra Low Voltage 12 Volts (excluding vehicle)

Battery/ies:

- Check battery/ies for condition.
- Check connections, wires, fuses and relays appertaining to the habitation electrics.

Wiring:

- Examine all visible wiring.
- Check all connections and joints are sound and satisfactory.

Fuses/Fuse Holders:

- Ensure that fuses and fuse holders used to protect the habitation electrics are satisfactory and that fuse ratings are compatible with the circuit appliances being protected.

Appliances:

- Inspect all appliances for damage, signs of overheating and secure fixing.
Function test all appliances.

Mains 230 Volt System

It is recommended that the inspection and certification of the 230 volt system be carried out by a qualified electrician who is an approved contractor of the NICEIC (National Inspection for Electrical Installation Contracting) or a member of the Electrical Contractors Association.



AUTO-SLEEPERS SERVICE CENTRE ANNUAL HABITATION CHECK

Introduction

It is recommended that every 12 months the habitation side of your motorhome is inspected by qualified technicians. Attached to this brief, is a list of all the points that are checked.

A few customers are of the belief that this check includes rectification of faults. It is stressed that this is not the case, the annual service is a check only of the habitation aspect of the motorhome.

If faults are found, the technician will advise you, the customer, of the fault and the recommended course of action to resolve this.

Servicing is not included in this check.

All facilities are run and tested through their operational envelope. For example, the flame propagation on the refrigerator and other main gas appliances (where visible) is checked. If the flame is burning a wrong colour or burning too far from the jet, we again advise you, the customer, as to how this should be rectified.

We also recommend and are able to arrange for the refrigerator of your vehicle to be checked here at the Service Centre by a qualified engineer. Our own on site personnel are qualified to service Dometic fridges and for other makes we will arrange for a visit by the appropriate service engineer.

The only component that is changed during the course of the annual check is the flexible gas hose, the hose that leads from the bulkhead fitting in the gas compartment to the gas regulator.

A further aspect of the test is a gas pressure test.

You will see also that we check that key components are serviceable (fire extinguishers etc) and furthermore that where appropriate, items are lubricated and checked for serviceability.



**MOTOR CARAVAN ANNUAL HABITATION SERVICE CHECK
CHECK SHEET** **CUSTOMER COPY**

Vehicle Reg. Mark
Make & Model
Year of Manufacture
Recorded Mileage

A Class
Coachbuilt
High top conversion
Elevating Roof
Dismountable

CHECK ITEM	Manual	OK	Remarks - Advice to Customers
------------	--------	----	-------------------------------

SECTION 1: BODY MOUNTING			
BODY TO CHASSIS			
BODY TO CAB			
BODY RETENTION			
SECTION 2: WINDOWS			
WINDOWS			
SECTION 3: DOORS			
EXTERNAL			
INTERNAL			
SECTION 4: CHASSIS			
CORNER STEADIES			
FOLDING STEP			
WATER TANK MOUNTS			
SPARE WHEEL			
WHEEL BOXES			
SECTION 5: BODY EXTERIOR			
ROOF LIGHTS			
ROOF RACK AND LADDER			
MOULDINGS AND TRIM			
FLUE TERMINALS, AIR VENTS			
SECTION 6: INTERNAL			
SEEPAGE CHECK			
FURNITURE			
DINETTE SEATS/BEDS			
CURTAINS, BLINDS, NETS			
CAB SEATS			
FIRE EXTINGUISHER			
FIRE BLANKET			
WARNING NOTICE			
HEATING EQUIPMENT			



SERVICE DETAILS



CHECK ITEM	Manual	OK	Remarks - Advice to Customers
SECTION 7: LIFT UP ROOFS			
LIFTING MECHANISM			
CANVAS SIDE WALLS			
SOLID SIDE WALLS			
LOCKING			
SECTION 8: GAS SYSTEM			
CYLINDERS & REGULATOR			
HOSE & PIPING			
APPLIANCES			
SECTION 9: WATER SYSTEM			
FRESH WATER TANK			
WASTE WATER TANK			
FILTER PUMP			
SYSTEM CHECK			
WASTE WATER SYSTEM			
COUPLINGS & FLUIDS			
SECTION 10: ELECTRICS			
12 VOLT SYSTEM			
BATTERIES			
WIRING			
FUSES, FUSE HOLDERS			
APPLIANCES			
MAINS 230 VOLT SYSTEM			
SECTION 11: VENTILATION			
HIGH LEVEL			
LOW LEVEL			

DEALER:	SIGNED:
	DATE:

A

Annual Service Checks	12-1
Awning	9-34

B

Bed Assembly	9-42, 9-43
Blinds	9-7

C

Carbon Monoxide Alarm	6-3
Cleaning	
General	10-1
Stainless Steel	10-2
Upholstery	10-2
Codes of Conduct	2-1
Cooker	9-1
Cooker Hood	9-7
Cycle Rack & Rear Ladder	4-1

D

Data Record	11-1
Dealer Addresses	11-2
Dimensions	8-4

E

Electricity	7-11
Instructions for Electricity Supply	7-11
Overseas Connection	7-12
Electronic Control System	9-46
Equipment Arrangement	9-36, 9-45

G

Gas	
Gas, General	7-4
Gas Safety Advice	7-7, 7-10

H

Heating	9-8
---------------	-----

I

Internal Layout	9-36
-----------------------	------

L

Levelling	5-1
Loading of Weight	3-1
Location of Facilities	9-39
LPG re-fuelling	7-5

M

Microwave	9-1
-----------------	-----

P

Parts List	9-44
Payload	8-3

R

Refrigerator	9-19
Regulator	7-4
Reversing Camera	9-33
Roof Loading	3-1

S

Safety	6-1
Air Bags	6-1
Awnings	6-1
Children	6-1
Fire Extinguishers	6-1
In case of fire	6-1
Ventilation	6-1
Safety, Air Bags	6-1
Seat Swivel	4-2
Seating Arrangement	9-36, 9-41
Servicing	10-1
Site Regulations	5-1
Siting your Motorhome	5-1
Sleeping Arrangement	9-40
Smoke Alarm	6-3
Step, Electric	9-33

T

Technical Data	8-1
Television	9-30
Television & Aerial	9-31
Toilet	9-26
Troubleshooting Chart	10-5

V

Ventilation	6-1, 7-9
-------------------	----------

W

Warranty	1-2
Water System	7-1
Weight & Dimension Data	8-3
Weights	8-1
Wheel Changing	4-1
Wheel, spare	4-1
Winterisation	10-3
Wiring Diagram	
12V/230V	7-34

