

USER ' S MANUAL

EBC-I855C

**Pentium® M
5.25" Embedded Card
With VGA/ SOUND/ 2LAN**

EBC-I855C

EBC-I855C Pentium® M
5.25" Embedded Card
With VGA /Sound/2LAN

OPERATION MANUAL

COPYRIGHT NOTICE

This operation manual is meant to assist both Embedded Computer manufacturers and end users in installing and setting up the system. The information contained in this document is subject to change without any notice.

This manual is copyrighted in August, 2004. You may not reproduce or transmit in any form or by any means, electronic, or mechanical, including photocopying and recording.

ACKNOWLEDGEMENTS

All trademarks and registered trademarks mentioned herein are the property of their respective owners.

CE NOTICE

This is a class A product. In a domestic environment this product may cause radio interference in which case the user may be required to take adequate measures.

FCC NOTICE

This equipment has been tested and found to comply with the limits for a Class A digital device, pursuant to part 15 of the FCC Rules. These limits are designed to provide reasonable protection against harmful interference when the equipment is operated in a commercial environment. This equipment generates, uses, and can radiate radio frequency energy and, if not installed and used in accordance with the instruction manual, may cause harmful interference to radio communications. Operation of this equipment in a residential area is likely to cause harmful interference in which case the user will be required to correct the interference at his own expense.

You are cautioned that any change or modifications to the equipment not expressly approve by the party responsible for compliance could void your authority to operate such equipment.

TABLE OF CONTENTS

CHAPTER 1 INTRODUCTION

1-1	About This Manual	1-2
1-2	System Specification	1-3
1-3	Safety Precautions	1-5

CHAPTER 2 HARDWARE CONFIGURATION

2-1	Jumper & Connector Quick Reference Table	2-2
2-2	Component Locations	2-3
2-3	How to Set the Jumpers	2-4
2-4	COM Port Connector	2-6
2-5	COM3/4 RI& Voltage Selection	2-8
2-6	RS232/422/485(COM2) Selection	2-9
2-7	Keyboard Connector	2-10
2-8	PS/2 Mouse Connector	2-10
2-9	Reset Connector	2-10
2-10	Hard Disk Drive LED Connector	2-11
2-11	ATX Power Button	2-11
2-12	External Speaker Connector	2-11
2-13	Power Led Connector	2-12
2-14	KeyLock Connector	2-12
2-15	EXTSMI Connector	2-12
2-16	IrDA Connector	2-13
2-17	CPU Fan Connector	2-13
2-18	System Fan Connector	2-13
2-19	VGA CRT Connector	2-14
2-20	Hard Disk Drive Connector	2-15
2-21	Floppy Disk Drive Connector	2-17
2-22	Printer Connector	2-18
2-23	Universal Serial Bus Connector	2-19
2-24	LAN Connector	2-20
2-25	GigaLAN (LAN2) Enable/Disable Selection	2-21
2-26	Clear CMOS Data Selection	2-21
2-27	AT/ATX Power Selection	2-22
2-28	ATX Power Connector	2-23
2-29	Reset/NMI Watchdog Selection	2-24

2-30	Inverter Connector	2-25
2-31	LVDS Connector	2-25
2-32	LVDS Panel Voltage Selection	2-26
2-33	Compact Flash Master/Slave Selection	2-26
2-34	DVO Connector	2-27
2-35	Sound Connector	2-28
2-36	CD-IN Connector	2-28

CHAPTER 3 SOFTWARE UTILITIES

3-1	Introduction	3-2
3-2	VGA Driver Utility	3-2
3-3	Flash BIOS Update	3-4
3-4	LAN Driver Utility	3-6
3-5	Sound Driver Utility	3-7
3-6	Intel Chipset Software Installation Utility	3-8
3-7	USB2.0 Software Installation Utility	3-9

CHAPTER 4 AWARD BIOS SETUP

4-1	Introduction	4-2
4-2	Entering Setup	4-3
4-3	The Standard CMOS Features	4-4
4-4	The Advanced BIOS Features	4-8
4-5	Advanced Chipset Features	4-11
4-6	Integrated Peripherals	4-14
4-7	Power Management Setup	4-19
4-8	PNP/PCI Configuration	4-22
4-9	PC Health Status	4-24
4-10	Frequency Control	4-25
4-11	Load Fail-Safe Defaults	4-26
4-12	Load Optimized Defaults	4-26
4-13	Password Setting	4-27
4-14	Save & Exit Setup	4-28
4-15	Exit Without Saving	4-29

APPENDIX A EXPANSION BUS

PCI Bus Pin Assignment	A-2
EPCI Connector	A-3
Compact Flash Card Connector Pin Assignment	A-4

APPENDIX B TECHNICAL SUMMARY

Block Diagram	B-2
Interrupt Map	B-3
RTC & CMOS RAM Map	B-4
Timer & DMA Channels Map	B-5
I/O & Memory Map	B-6

INTRODUCTION

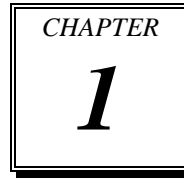

This chapter gives you the information for EBC-I855C. It also outlines the System specification.

Section includes:

- About This Manual
- System Specifications
- Safety precautions

Experienced users can skip to chapter 2 on page 2-1 for Quick Start.

1-1. ABOUT THIS MANUAL

Thank you for purchasing our EBC-I855C Socket 478 Pentium M 5.25" Embedded Card enhanced with VGA /Sound/ 2LAN, which is fully PC / AT compatible. EBC-I855C provides faster processing speed, greater expandability and can handle more task than before. This manual is designed to assist you how to install and set up the system. It contains four chapters. The user can apply this manual for configuration according to the following chapters :

Chapter 1 Introduction

This chapter introduces you to the background of this manual, and the specification for this system. Final part of this chapter will indicate you how to avoid damaging this Embedded Card.

Chapter 2 Hardware Configuration

This chapter outlines the component location and their functions. In the end of this chapter, you will learn how to set jumper and how to configure this card to meet your own needs.

Chapter 3 Software Utilities

This chapter contains helpful information for proper installations of the VGA utility, LAN utility, sound utility, and BIOS update. It also describes the Watchdog timer configuration.

Chapter 4 Award BIOS Setup

This chapter indicates you how to set up the BIOS configurations.

Appendix A Expansion Bus

This Appendix introduces you the expansion bus for PCI Bus and EPCI Bus.

Appendix B Technical Summary

This section gives you the information about the Technical maps.

Appendix C Trouble Shooting

This section outlines the error messages and offers you the methods to solve the problems.

1-2. SYSTEM SPECIFICATION

- **CPU (mPGA 478) :**
 - Intel® Pentium® M processor in mPGA478 socket
 - Available at 1.3~ 1.8GHz
 - System bus frequency at 400MHz
 - Auto detect voltage regulator

- **SYSTEM CHIPSET :**
 - Intel® 855GME chipset

- **MEMORY :**
 - Supports up to 2 GB DDR SDRAM.
 - Two 184-pin DDR SO-DIMM sockets on board

- **CACHE :**
 - Built-in CPU

- **REAL-TIME CLOCK / CALENDAR :**
 - 256-byte battery backed CMOS RAM.
 - Hardware implementation to indicate century rollover

- **BIOS :**
 - Phoenix-AwardBIOS™ for plug & play function
 - Memory size with 4 MB, with VGA BIOS

- **KEYBOARD/MOUSE CONNECTOR :**
 - Keyboard with 1 x 4 pin wafer connector.
 - PS/2 mouse connector with 1 x 4 pin wafer connector.

- **UNIVERSAL SERIAL BUS :**
 - Universal Serial Bus Connector on board
 - Supports up to six USB 2.0 ports.

- **BUS SUPPORT :**
 - PCI Bus
 - External EPCI Bus
 - Compact Flash Bus (for secondary IDE-based)

- **DISPLAY :**
Built in Intel 855GME, support CRT, LCD.
- **IDE INTERFACE :**
Two IDE ports support up to four IDE devices.
Supports UDMA 33/66/100.
- **FLOPPY DISK DRIVER INTERFACE :**
Supports up to two Floppy Disk Drives, 3.5" and 5.25".
- **LAN INTERFACE :**
Dual ports.
LAN 1: Intel® 82562ET 10/100 Mbps Ethernet.
LAN 2: Intel® 82541GI (10/100/1000).
Supports Wake-on-LAN with ATX power.
- **SOUND:**
AC '97 Codec. Reatel ALC202A.
Fully Compliant AC '97 Analog I/O Component
- **SERIAL PORT :**
Two high speed 16550 Compatible UARTs with Send / Receive 16 Byte FIFOs. COM1 for RS232; COM2 for RS232/422/485.
- **PARALLEL PORT :**
One port supports SPP / ECP / EPP Function.
- **HARDWARE MONITORING FUNCTION :**
Monitor Voltage, CPU Temperature and Cooling Fan.
- **IRDA PORT :**
One 5-pin Infrared connector
Supports IrDA v1.0 SIR protocol.
- **LED INDICATOR :**
HDD LED, Power LED.
- **DMA CONTROLLER :**
82C37 x 2

● **DMA CHANNELS :**

7

● **INTERRUPT CONTROLLERS :**

82C59 x 2

● **INTERRUPT LEVELS :**

15

● **OPERATING TEMPERATURE :**

0 to 60°C (32°F to 140°F)

● **INPUT POWER REQUIREMENT :**

ATX power: +5V, +12V.

AT power:

● **BOARD DIMENSION :**

203mm x 146mm (7.99" x 5.75")

● **BOARD NET WEIGHT :**

290 grams (0.64 lb)

1-3. SAFETY PRECAUTIONS

Follow the messages below to avoid your systems from damage:

1. Avoid your system from static electricity on all occasions.
2. Prevent electric shock. Don't touch any components of this card when the card is power-on. Always disconnect power when the system is not in use.
3. Disconnect power when you change any hardware devices. For instance, when you connect a jumper or install any cards, a surge of power may damage the electronic components or the whole system.

HARDWARE CONFIGURATION

CHAPTER

2

**** *QUICK START* ****

Helpful information describes the jumper & connector settings, and component locations.

Section includes:

- Jumper & Connector Quick Reference Table
- Component Locations
- Configuration and Jumper settings
- Connector's Pin Assignments

2-1. JUMPER & CONNECTOR QUICK REFERENCE TABLE

COM Port Connector	COM1, COM2 COM3, COM4
COM3/4 RI/Voltage Selection	JP5
RS232/422/485 (COM2) Selection	JP4
Keyboard Connector	KB1
Mouse Connector	MS1
Reset Connector	J3 (18,20)
Hard Disk Drive LED Connector	J3 (12,14)
ATX Power Button	J3 (13,15)
External Speaker Connector	J3 (2,4,6,8)
Power LED Connector	J3 (1,3,5)
KeyLock Connector	J3 (7,9)
EXTSMI Connector	J3 (17,19)
IrDA Connector	JIRDA1
CPU Fan Connector	FAN1
System Fan Connector	FAN2
VGA Connector	VGA1
Hard Disk Drive Connector	IDE1, IDE2
Floppy Disk Drive Connector	FDD1
Printer Connector	LPT1
Universal Serial Bus Connector	USB1, USB2
LAN Connector	J1, J2
GigaLAN Enable/Disable Selection	JP9
Clear CMOS Data Selection	JP1
AT/ATX Power Selection	JP8
ATX Power Connector	PW1
Reset/NMI/Clear Watchdog Selection	JP6
Inverter Connector	J7
LVDS Connector	J8
LVDS Voltage Selection	JP10
Compact Flash Master/Slave Selection	JP7
DVO Connector	DVO1
Sound Connector	JAUDIO1
CD-IN Connector	CD_IN1

2-2. COMPONENT LOCATIONS

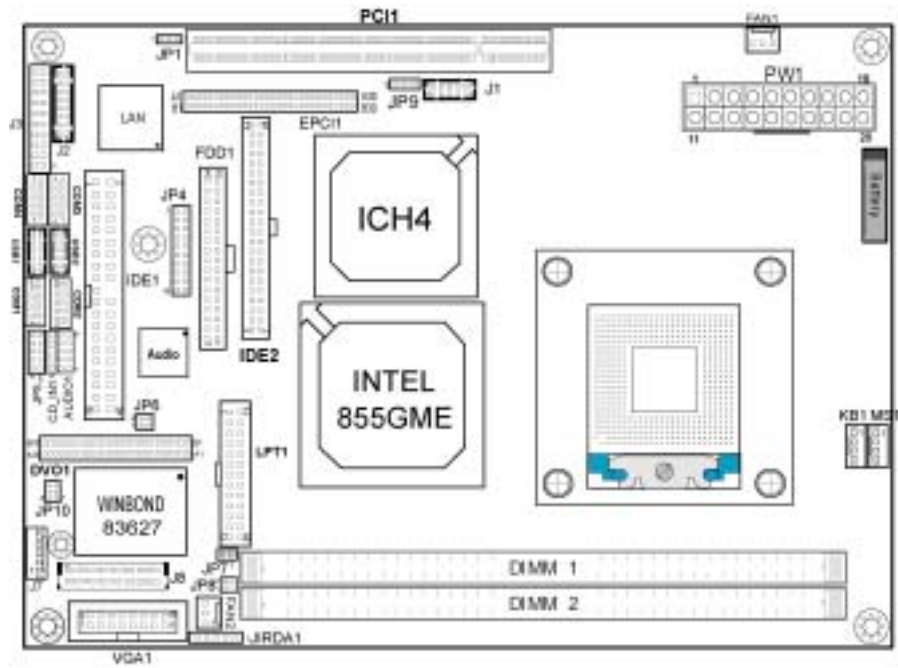

EBC-I855C Connector, Jumper and Component locations

2-3. HOW TO SET THE JUMPERS

You can configure your board by setting jumpers. Jumper is consists of two or three metal pins with a plastic base mounted on the card, and by using a small plastic "cap", Also known as the jumper cap (with a metal contact inside), you are able to connect the pins. So you can set-up your hardware configuration by "open" or "close" pins.

The jumper can be combined into sets that called jumper blocks. When the jumpers are all in the block, you have to put them together to set up the hardware configuration. The figure below shows how this looks like.

JUMPERS AND CAPS

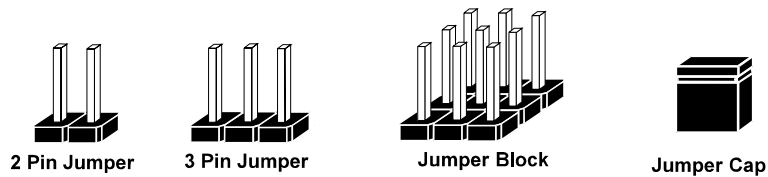

If a jumper has three pins (for examples, labelled PIN1, PIN2, and PIN3), You can connect PIN1 & PIN2 to create one setting and shorting. You can either connect PIN2 & PIN3 to create another setting. The same jumper diagrams are applied all through this manual. The figure below shows what the manual diagrams look and what they represent.

JUMPER DIAGRAMS



Jumper Cap
looks like this



2 pin Jumper
looks like this

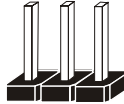

3 pin Jumper
looks like this

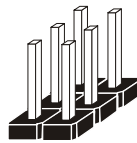

Jumper Block
looks like this

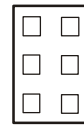

JUMPER SETTINGS



2 pin Jumper close(enabled)
Looks like this



3 pin Jumper
2-3 pin close(enabled)
Looks like this

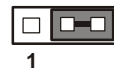

Jumper Block
1-2 pin close(enabled)
Looks like this

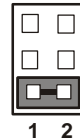

2-4. COM PORT CONNECTOR

COM1 : COM1 Connector

COM1 is fixed as RS-232.

The pin assignment is as follows :

PIN	ASSIGNMENT
1	DCD1
2	RX1
3	TX1
4	DTR1
5	GND
6	DSR1
7	RTS1
8	CTS1
9	RI1
10	NC

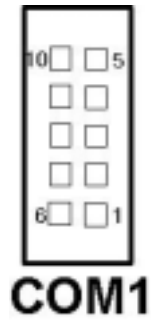

COM2 : COM2 Connector

The COM2 is selectable as RS-232/422/485.

The pin assignment is as follows :

PIN	ASSIGNMENT		
	RS-232	RS-422	RS-485
1	DCD2	TX-	TX-
2	RX2	TX+	TX+
3	TX2	RX+	RX+
4	DTR2	RX-	RX-
5	GND	GND	GND
6	DSR2	RTS-	NC
7	RTS2	RTS+	NC
8	CTS2	CTS+	NC
9	RI2	CTS-	NC
10	NC	NC	NC

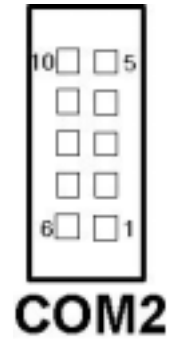

COM3 : COM3 Connector

COM1 is fixed as RS-232.

The pin assignment is as follows :

PIN	ASSIGNMENT
1	DCD3
2	RX3
3	TX3
4	DTR3
5	GND
6	DSR3
7	RTS3
8	CTS3
9	RI-V3
10	NC

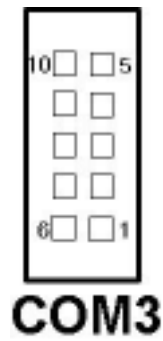

COM4 : COM4 Connector

COM1 is fixed as RS-232.

The pin assignment is as follows :



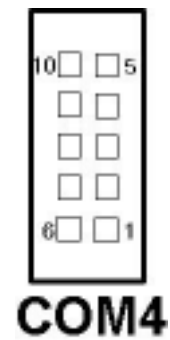

PIN	ASSIGNMENT
1	DCD4
2	RX4
3	TX4
4	DTR4
5	GND
6	DSR4
7	RTS4
8	CTS4
9	RI-V4
10	NC

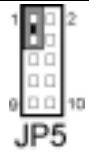
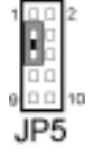

2-5. COM3/4 RI & VOLTAGE SELECTION

JP5 : COM3/4 RI & Voltage Selection

The selections are as follows:

SELECTION		JUMPER SETTINGS	JUMPER ILLUSTRATION
COM3	RI	7-9	
	+12	1-3	
	+5V	3-5	
COM4	RI	8-10	
	+12	2-4	
	+5V	4-6	

***Manufacturing Default – RI.

2-6. RS232/422/485 (COM2) SELECTION

JP4 : RS-232/422/485 (COM2) Selection

This connector is used to set the COM2 function.

The jumper settings are as follows :

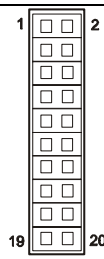
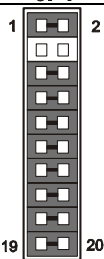
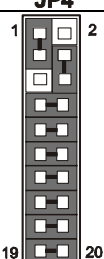
COM 2 Function	Jumper Settings (pin closed)	Jumper Illustrations
RS-232	Open	 <p>Diagram of JP4 jumper connector showing all 20 pins (1-20) open. The pins are arranged in two columns of 10, labeled 1-2 on the top and 19-20 on the bottom. The label JP4 is centered below the connector.</p>
RS-422	1-2, 5-6, 7-8 9-10, 11-12, 13-14 15-16, 17-18, 19-20	 <p>Diagram of JP4 jumper connector showing pairs of pins 1-2, 5-6, 7-8, 9-10, 11-12, 13-14, 15-16, 17-18, and 19-20 closed. The label JP4 is centered below the connector.</p>
RS-485	1-3, 4-6, 7-8, 9-10 11-12, 13-14, 15-16 17-18, 19-20	 <p>Diagram of JP4 jumper connector showing pairs of pins 1-3, 4-6, 7-8, 9-10, 11-12, 13-14, 15-16, 17-18, and 19-20 closed. The label JP4 is centered below the connector.</p>

*** Manufactory default --- RS-232.

2-7. KEYBOARD CONNECTOR

KB1 : Keyboard Connector

The pin assignments are as follows :

PIN	ASSIGNMENT
1	KBCLK
2	KBDAT
3	GND
4	KBMSVCCL



2-8. MOUSE CONNECTOR

MS1 : Mouse Connector

The pin assignments are as follows :

PIN	ASSIGNMENT
1	MSCLK
2	MSDAT
3	GND
4	KBMSVCCL



2-9. RESET CONNECTOR

J3 (18,20) : Reset Connector.

The pin assignment is as follows :

PIN	ASSIGNMENT
18	HWRSTJ
20	GND



2-10. HARD DISK DRIVE LED CONNECTOR

J3 (12, 14) : Hard Disk Drive LED Connector
The pin assignment is as follows :

PIN	ASSIGNMENT
12	P_HLED
14	PULL HIGH VCC

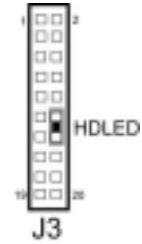

2-11. ATX POWER BUTTON

J3 (13, 15) : ATX Power Button
The pin assignment is as follows :

PIN	ASSIGNMENT
13	PW_BTN1
15	PW_BTN2

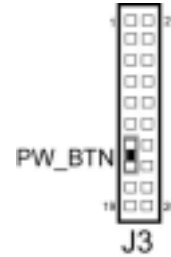

2-12. EXTERNAL SPEAKER CONNECTOR

J3 (2, 4, 6, 8) : External Speaker Connector
The pin assignment is as follows :

PIN	ASSIGNMENT
2	+5V
4	GND
6	NC
8	P_SPK

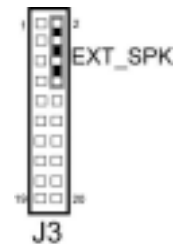

2-13. POWER LED CONNECTOR

J3 (1, 3, 5) : Power LED Connector
 The pin assignment is as follows:

PIN	ASSIGNMENT
1	PW_LED
3	PW_LED
5	GND

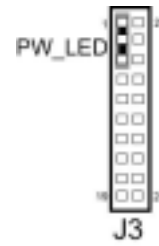

2-14. KEYLOCK CONNECTOR

J3 (7, 9) : Keylock Connector
 The pin assignment is as follows:

PIN	ASSIGNMENT
7	KEYLOCK
9	GND

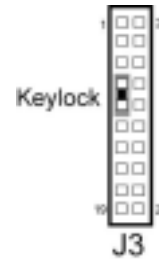

2-15. EXTSMI CONNECTOR

J3 (17, 19) : EXTSMI Connector
 The pin assignment is as follows:

PIN	ASSIGNMENT
17	P_ESMI
19	GND

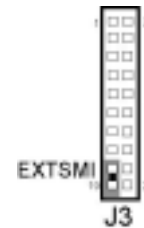

2-16. IRDA CONNECTOR

JIRDA1: IrDA (Infrared) Connector
The pin assignments are as follows:

PIN	ASSIGNMENT
1	+5V
2	NC
3	IRRX
4	GND
5	IRTX



2-17. CPU FAN CONNECTOR

FAN1 : CPU Fan connector
The pin assignment is as follows:

PIN	ASSIGNMENT
1	GND
2	+12V
3	FANIO1



2-18. SYSTEM FAN CONNECTOR

FAN2 : System Fan connector
The pin assignment is as follows:

PIN	ASSIGNMENT
1	GND
2	+12V
3	FANIO2



2-19. VGA CONNECTOR

VGA1 : VGA CRT Connector

The pin assignments are as follows:



PIN	ASSIGNMENT
1	RED
2	GREEN
3	BLUE
4	NC
5	GND
6	GND
7	GND
8	GND
9	VGA_P5V
10	GND
11	NC
12	VGA_5VDDA
13	VGA_HSYNC_5V
14	VGA_VSYNC_5V
15	VGA_5VDDCLK
16	NC

2-20. HARD DISK DRIVE CONNECTOR

IDE1: Hard Disk Drive Connector

The pin assignments are as follows:

PIN	ASSIGNMENT	PIN	ASSIGNMENT
1	IDERSTJ	2	GND
3	PDD7	4	PDD8
5	PDD6	6	PDD9
7	PDD5	8	PDD10
9	PDD4	10	PDD11
11	PDD3	12	PDD12
13	PDD2	14	PDD13
15	PDD1	16	PDD14
17	PDD0	18	PDD15
19	GND	20	NC
21	PDREQ	22	GND
23	PDIOWJ	24	GND
25	PDIORJ	26	GND
27	PIORDY	28	PULL LOW
29	PDDACKJ	30	GND
31	IRQ14S	32	NC
33	PDA1	34	P66 DET
35	PDA0	36	PDA2
37	PDCSJ1	38	PDCSJ3
39	IDEACTPJ	40	GND

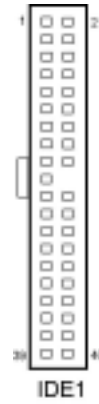

IDE2: Hard Disk Drive Connector

The pin assignments are as follows:

PIN	ASSIGNMENT	PIN	ASSIGNMENT
1	IDERSTJ	2	GND
3	SDD7	4	SDD8
5	SDD6	6	SDD9
7	SDD5	8	SDD10
9	SDD4	10	SDD11
11	SDD3	12	SDD12
13	SDD2	14	SDD13
15	SDD1	16	SDD14
17	SDD0	18	SDD15
19	GND	20	NC
21	SDREQ	22	GND
23	SDIOWJ	24	GND
25	SDIORJ	26	GND
27	SIORDY	28	PULL LOW
29	SDDACKJ	30	GND
31	IRQ15S	32	NC
33	SDA1	34	S66 DET
35	SDA0	36	SDA2
37	SDCSJ1	38	SDCSJ3
39	IDEACTSJ1	40	GND
41	+5V	42	+5V
43	GND	44	GND

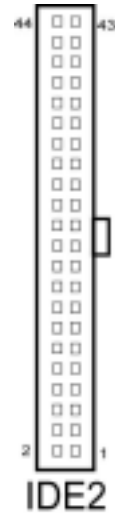

2-21. FLOPPY DISK DRIVE CONNECTOR

FDD1 : Floppy Disk Drive Connector

You can use a 34-pin daisy-chain cable to connect two-FDDs. On one end of this cable is a 34-pin flat cable to attach the FDD on the board, and the other side is attaches two FDDs.

The pin assignments are as follows :

PIN	ASSIGNMENT	PIN	ASSIGNMENT
1	GND	2	RWCJ
3	GND	4	NC
5	NC	6	DS1J
7	GND	8	INDEX
9	GND	10	MOAJ
11	GND	12	DSBJ
13	GND	14	DSAJ
15	GND	16	MOBJ
17	GND	18	DIRJ
19	GND	20	STEPJ
21	GND	22	WDJ
23	GND	24	WEJ
25	GND	26	TRAK0
27	GND	28	WP#
29	NC	30	RDATA
31	GND	32	HEADJ
33	NC	34	DSKCHG



2-22. PRINTER CONNECTOR

PRNT1 : Printer Connector

As to link the Printer to the card, you need a cable to connect both DB25 connector and parallel port.

The pin assignments are as follows :

PIN	ASSIGNMENT	PIN	ASSIGNMENT
1	RSTBJ	14	AFDJ
2	RPD0	15	ERRJ
3	RPD1	16	PAR_INITJ
4	RPD2	17	SLINJ
5	RPD3	18	GND
6	RPD4	19	GND
7	RPD5	20	GND
8	RPD6	21	GND
9	RPD7	22	GND
10	ACKJ	23	GND
11	BUSY	24	GND
12	PE	25	GND
13	SLCT	26	NC

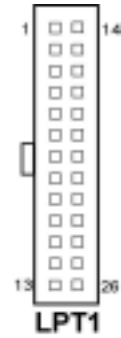

2-23. UNIVERSAL SERIAL BUS CONNECTOR

USB1: Universal Serial Bus Connector
The pin assignments are as follows:

PIN	ASSIGNMENT
1	VCCUSB0
2	VCCUSB1
3	USBP0N
4	USBP1N
5	USBP0P
6	USBP1P
7	GND
8	GND
9	GND
10	GND

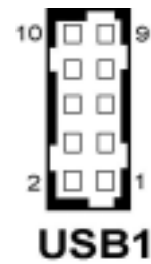

USB2: Universal Serial Bus Connector
The pin assignments are as follows:

PIN	ASSIGNMENT
1	VCCUSB2
2	UCCUSB3
3	USBP2N
4	USBP3N
5	USBP2P
6	USBP3P
7	GND
8	GND
9	GND
10	GND

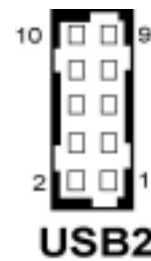

2-24. LAN CONNECTOR

LAN1: LAN Connector

The pin assignments are as follows:

PIN	ASSIGNMENT
1	TDP
2	PULL HIGH VCC3_3 Stand By
3	TDN
4	LILEDJ
5	GND
6	SPLEDJ
7	RDP
8	ACTLEDJ
9	RDN
10	NC

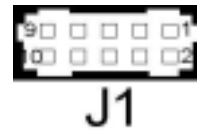

LAN2: LAN Connector

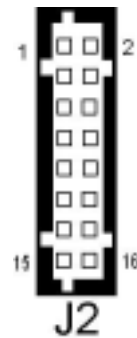

The pin assignments are as follows:

PIN	ASSIGNMENT
1	1MDI_3+
2	1MDI_3-
3	1MDI_2+
4	1MDI_2-
5	1MDI_1+
6	1MDI_1-
7	1MDI_0+
8	1MDI_0-
9	VCC25-CG
10	GND
11	1VCC3.3R
12	GND
13	1LINK-R
14	1ACT
15	1SPEED100
16	1SPEED1000-R



2-25. GIGALAN ENABLE/DISABLE SELECTION



JP9: GigaLAN Enable/Disable Selection.
The selections are as follows:

FUNCTION	JUMPER SETTING (pin closed)	JUMPER ILLUSTRATION
Enable	open	 JP9
Disable	2-3	 JP9

***Manufacturing Default is set as Enable.

2-26. CLEAR CMOS DATA SELECTION

JP1 : Clear CMOS Data Selection
The selections are as follows :



FUNCTION	JUMPER SETTING (pin closed)	JUMPER ILLUSTRATION
Normal	2-3	 JP1
Clear CMOS	1-2	 JP1

*** Manufacturing Default is set as Normal.

Note: To clear CMOS data, user must power-off the computer and set the jumper to "Clear CMOS" as illustrated above. After five to six seconds, set the jumper back to "Normal" and power-on the computer.

2-27. AT/ATX POWER SELECTION

JP8 : AT/ATX Power Selection
The selections are as follows:

Power Selection	JUMPER SETTINGS (pin closed)	JUMPER ILLUSTRATION
AT	1-2, 3-4	 JP8
ATX	Open	 JP8

** Manufacturing default: ATX**

2-28. ATX POWER CONNECTOR

PW1 : ATX Power Connector

The pin assignments are as follows:





PIN	ASSIGNMENT
1	+3.3V
2	+3.3V
3	GND
4	+5V
5	GND
6	+5V
7	GND
8	NC
9	5VSB
10	+12V
11	+3.3V
12	-12V
13	GND
14	PS_ON
15	GND
16	GND
17	GND
18	-5V
19	+5V
20	+5V

2-29. RESET/NMI WATCHDOG SELECTION

JP6 : Reset/NMI Watchdog Selection

The selections are as follows:

FUNCTION	JUMPER SETTING (pin closed)	JUMPER ILLUSTRATION
RESET	1-2	 JP6
NMI	3-4	 JP6

** Manufacturing default: Reset.

 User may select to use the Reset or NMI watchdog. NMI, also known as Non-Maskable Interrupt, is used for serious conditions that demand the processor's immediate attention, it cannot be ignored by the system unless it is shut off specifically.

2-30. INVERTER CONNECTOR

J7 : Inverter Connector
 The pin assignment is as follows:



PIN	ASSIGNMENT
1	+12
2	GND
3	+5V
4	GND
5	LVDS_BKLTEN

2-31. LVDS CONNECTOR

J8 : LVDS Connector.
 The pin assignments are as follows:

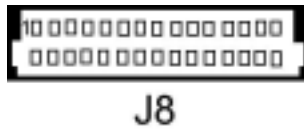



PIN	ASSIGNMENT	PIN	ASSIGNMENT
1	LVDS_VCC	2	GND
3	ZCM	4	ZCP
5	GND	6	Z2M
7	Z2P	8	GND
9	Z1M	10	Z1P
11	Z3P	12	Z3M
13	Z0P	14	Z0M
15	GND	16	YCP
17	YCM	18	GND
19	Y2P	20	Y2M
21	GND	22	Y1P
23	Y1M	24	GND
25	Y0P	26	Y0M
27	Y3P	28	Y3M
29	LVDS_VCC	30	LVDS_VCC

2-32. LVDS PANEL VOLTAGE SELECTION

JP10 : LVDS Panel Voltage Selection.

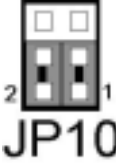

The selections are as follows:

SELECTION	JUMPER SETTING	JUMPER ILLUSTRATION
LVDS_VCC3	1-3, 2-4	
LVDS_VCC5	3-5, 4-6	

2-33. COMPACT FLASH MASTER/SLAVE SELECTION

JP7 : Compact Flash Master/ Slave Selection

The selections are as follows:

Power Selection	JUMPER SETTINGS (pin closed)	JUMPER ILLUSTRATION
Master	1-2	
Slave	Open	

** Manufacturing default: Master**

2-34. DVO CONNECTOR

DVO1 : DVO Connector.

The pin assignments are as follows:



DVO1

PIN	ASSIGNMENT	PIN	ASSIGNMENT
A1	+5V	B1	+12V
A2	+5V	B2	+12V
A3	+5V	B3	GND
A4	+3.3V	B4	GND
A5	+3.3V	B5	DVOB_D0
A6	VDDQ	B6	DVOB_D1
A7	MI2C_DATA	B7	DVOB_D2
A8	MI2C_CLK	B8	DVOB_D3
A9	DVOB_BLANKJ	B9	DVOB_D4
A10	DVOB_FLDSTL	B10	DVOB_D5
A11	GND	B11	DVOB_D6
A12	DVOB_CLK	B12	DVOB_D7
A13	DVOB_CLKJ	B13	DVOB_D8
A14	GND	B14	DVOB_D9
A15	DVOB_VSYNC	B15	DVOB_D10
A16	DVOB_HSYNC	B16	DVOB_D11
A17	MDVI_CLK	B17	DVOBC_INTRJ
A18	MDVI_DATA	B18	ADDDETECT
A19	PCIRSTJ	B19	ADDID4
A20	DVOB_CCLKINTJ	B20	ADDID5
A21	ADDID0	B21	ADDID6
A22	ADDID1	B22	ADDID7
A23	ADDID2	B23	REF14.318M
A24	ADDID3	B24	VCC_DIMM
A25	DVO_VREF	B25	VCC_DIMM

2-35. SOUND CONNECTOR

JAUDIO1 : Sound Connector.

The pin assignments are as follows:

PIN	ASSIGNMENT
1	MIC-IN
2	NC
3	GND
4	GND
5	LINE-L
6	LINE-R
7	GND
8	GND
9	SPK-L
10	SPK-R

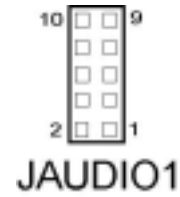

2-36. CD-IN CONNECTOR

CD-IN1 : CD-IN Connector.

The pin assignments are as follows:

PIN	ASSIGNMENT
1	CD-L
2	CD_REF
3	CD_REF
4	CD-R



SOFTWARE UTILITIES

CHAPTER 3

This chapter comprises the detailed information of VGA driver, LAN driver, and Flash BIOS update. It also describes how to install the watchdog timer configuration.

Section includes:

- VGA Driver Utility
- Flash BIOS Update
- LAN Driver Utility
- Sound Driver Utility
- Intel® Chipset Software Installation Utility
- USB2.0 Chipset Software Installation Utility

3-1. INTRODUCTION

Enclosed with our EBC-I855C package is our driver utility, which may come in a form of a CD ROM disc or floppy diskettes. For CD ROM disc user, you will only need some of the files contained in the CD ROM disc, please kindly refer to the following chart:

Filename (Assume that CD ROM drive is D:)	Purpose
D:\VGA	Intel 855GME For VGA driver installation
D:\AWDFLASH	For BIOS update utility
D:\LAN	For LAN Driver installation
D:\SOUND	Realtek ALC202A AC97 For Sound driver installation
D:\UTILITY	Intel® Chipset Software Installation Utility For Win 98SE, ME, 2000, XP
D:\USB 2.0	USB 2.0 Software Installation Utility For Win 98SE, 2000, ME, XP

 User should remember to install the Utility right after the OS fully installed.

3-2. VGA DRIVER UTILITY

The VGA interface embedded with our EBC-I855C can support a wide range of display. You can display CRT, LVDS simultaneously with the same mode.

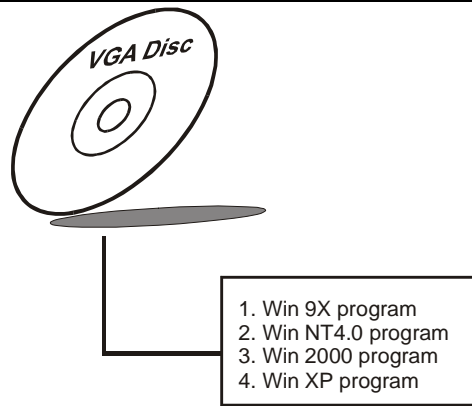

3-2-1. Installation of VGA Driver:

To install the VGA Driver, simply follow the following steps:

1. Place insert the Utility Disk into Floppy Disk Drive A/B or CD ROM drive.
2. Under Windows 9X/NT4.0/2000/XP system, go to the directory where VGA driver is located.
3. Click **Setup.exe** file for VGA driver installation.
4. Follow the instructions on the screen to complete the installation.
5. Once installation is completed, shut down the system and restart in order for the changes to take effect.

⚠ Under the Windows 98 system, after reboot computer, there will have two error messages appear, "Can't find ikch8xx.cat and isb8xx.cat", just skip the messages, they will not cause any effects.

3-3. FLASH BIOS UPDATE

3-3-1. System BIOS Update:

Users of EBC-I855C can use the program "Awdflash.exe" contained in the Utility Disk for system BIOS and VGA BIOS update.

3-3-2. To update VGA BIOS for LCD Flat Panel Display:

As EBC-I855C user, you have to update the VGA BIOS for your specific LCD flat panel you are going to use. For doing this, you need two files. One is the "Awdflash.exe" file and the other is the VGA BIOS for ATI Rage Mobility M6 file for LCD panel display. Both file must be provided by the vendor or manufacturer. When you get these two files ready, follow the following steps for updating your VGA BIOS:

1. Install "Awdflash.exe" from Utility Disk to Drive C.
2. Insert the VGA BIOS file you have obtained from the vendor.
Type the path to Awdflash.exe and execute the VGA BIOS update with file H15bxxxx.bin
3. C:\UTIL\AWDFLASH>AWDFLASH H15bxxxx.bin
4. The screen will display as the table found on the next page:

FLASH MEMORY WRITER v7.XX (C) Award Software 2001 All Rights Reserved
Flash Type – SST 49LF004A /3.3V File Name to Program: H20bxxxx.bin Checksum: XXXXX
Error Message: Do You Want To Save BIOS (Y/N)

If you want to save up the original BIOS, enter "Y" and press < Enter >. If you choose "N", the following table will appear on screen.

FLASH MEMORY WRITER v7.XX (C) Award Software 2001 All Rights Reserved
Flash Type – SST 49LF004A /3.3V File Name to Program: H20bxxxx.bin Checksum: XXXXX
Error Message : Are You Sure To Program (Y/N)

Select "Y", and the BIOS will be renewed. When you are refreshing the BIOS, do not turn off or reset the system, or you will damage the BIOS. After you have completed all the programming, the screen displays the table below:

FLASH MEMORY WRITER v7.XX (C) Award Software 2001 All Rights Reserved
Flash Type – SST 49LF004A /3.3V File Name to Program: H20bxxxx.bin Checksum: XXXXX Reset System or Power off to accomplish update process!
F1: Reset F10: Exit

Please reset or power off the system, and then the Flash BIOS is fully implemented.

3-4. LAN DRIVER UTILITY

3-4-1. Introduction

EBC-I855C is enhanced with LAN function that can support various network adapters. Installation programs for LAN drivers are listed as follows:

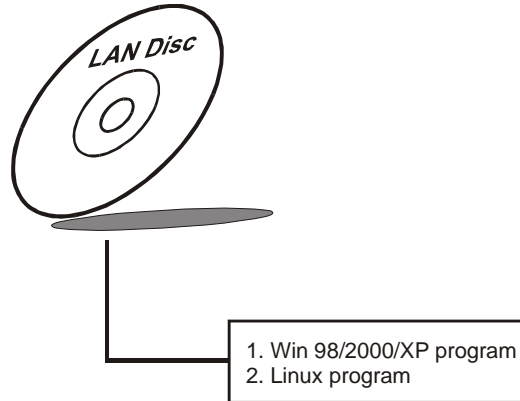

For more details on Installation procedure, please refer to Readme.txt file found on LAN DRIVER UTILITY.

3-5. SOUND DRIVER UTILITY

3-5-1. Introduction

The Realtek ALC202A sound function enhanced in this system is fully compatible with Windows 98, Windows 98SE, Windows NT 4.0, Windows 2000, Windows ME and Windows XP. Below, you will find the content of the Sound driver :

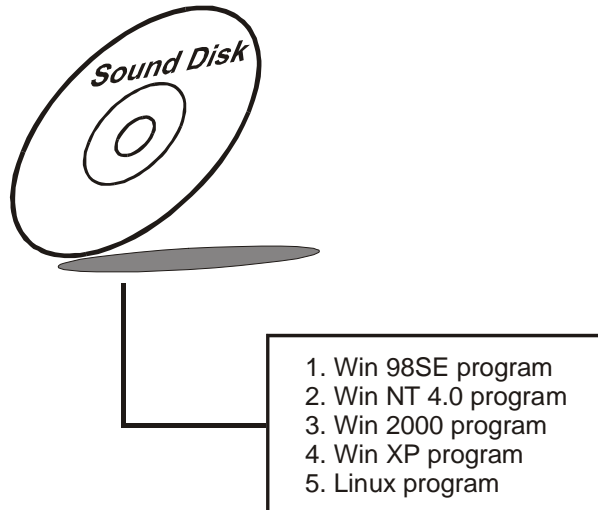

3-5-2. Installation Procedure for Windows 9x/NT/2000/XP

1. From the task bar, click on Start, and then Run.
2. In the Run dialog box, type D:\Sound\path\setup, where "D:\Sound\pathname" refers to the full path to the source files.
3. Click on the OK button or press the ENTER key.
4. Click on the "Next" and OK prompts as they appear.
5. Reboot the system to complete the driver installation.

3-6. INTEL® CHIPSET SOFTWARE INSTALLATION UTILITY

3-6-1. Introduction

The Intel® Chipset Software Installation Utility installs to the target system the Windows* INF files that outline to the operating system how the chipset components will be configured. This is needed for the proper functioning of the following features:

- Core PCI and ISAPNP Services
- AGP Support
- IDE/ATA33/ATA66/ATA100 Storage Support
- USB Support
- Identification of Intel® Chipset Components in Device Manager

3-6-2. Installation of Utility for Windows 98SE/ME/2000/XP

The Utility Pack is to be installed only for Windows 98SE, Windows ME, Windows 2000 and XP program.

It should be installed right after the OS installation, kindly follow the following steps:

1. Place insert the Utility Disk into Floppy Disk Drive A/B or CD ROM drive.
2. Under Windows 98SE/ME/2000/XP system, go to the directory where Utility Disc is located.
3. Click **Setup.exe** file for utility installation.
4. Follow the instructions on the screen to complete the installation.
5. Once installation is completed, shut down the system and restart in order for the changes to take effect.

3-7. USB2.0 SOFTWARE INSTALLATION UTILITY

3-7-1. Installation of Utility for Windows 98SE/ 2000/XP

Intel USB 2.0 Enhanced Host Controller driver can only be used on Windows 98SE, Windows 2000 and Windows XP on Intel Desktop boards. It should be installed right after the OS installation, kindly follow the following steps:

1. Place insert the Utility Disk into Floppy Disk Drive A/B or CD ROM drive.
2. Under Windows 98SE, 2000, and XP system, go to the directory where Utility Disc is located.
3. Start the "System" wizard in control panel. (Click Start/Settings/Control Panel).
4. Select "Hardware" and click "Device Manager" button.
5. Double Click "USB Root Hub".
6. Select "Driver".
7. Click "Install" to install the driver.
8. Follow the instructions on the screen to complete the installation.
9. Click "Finish" after the driver installation is complete.

AWARD BIOS SETUP

CHAPTER 4

This chapter shows how to set up the Award BIOS.

Section includes:

- Introduction
- Entering Setup
- The Standard CMOS Features
- The Advanced BIOS Features
- The Advanced Chipset Features
- Integrated Peripherals
- Power Management Setup
- PNP/PCI Configuration
- PC Health Status
- Frequency Control
- Load Fail-Safe Defaults
- Load Optimized Defaults
- Password Setting
- Save and Exit Setup
- Exit Without Saving

4-1. INTRODUCTION

This chapter will show you the function of the BIOS in managing the features of your system. The EBC-I855C Intel® Pentium® M 5.25" Embedded Card is equipped with the BIOS for system chipset from Award Software Inc. This page briefly explains the function of the BIOS in managing the special features of your system. The following pages describe how to use the BIOS for system chipset Setup menu.

Your application programs (such as word processing, spreadsheets, and games) rely on an operating system such as DOS or OS/2 to manage such things as keyboard, monitor, disk drives, and memory.

The operating system relies on the BIOS (Basic Input and Output system), a program stored on a ROM (Read-only Memory) chip, to initialize and configure your computer's hardware. As the interface between the hardware and the operating system, the BIOS enables you to make basic changes to your system's hardware without having to write a new operating system.

The following diagram illustrates the interlocking relationships between the system hardware, BIOS, operating system, and application program:

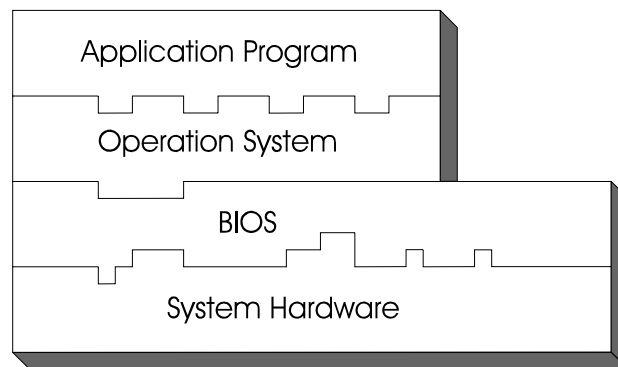

4-2. ENTERING SETUP

When the system is powered on, the BIOS will enter the Power-On Self Test (POST) routines and the following message will appear on the lower screen:

PRESS TO ENTER SETUP, ESC TO SKIP MEMORY TEST

As long as this message is present on the screen you may press the key (the one that shares the decimal point at the bottom of the number keypad) to access the Setup program. In a moment, the main menu of the Award SETUP program will appear on the screen:

Phoenix - AwardBIOS CMOS Setup Utility	
<ul style="list-style-type: none"> ▶ Standard CMOS Features ▶ Advanced BIOS Features ▶ Advanced Chipset Features ▶ Integrated Peripherals ▶ Power Management Setup ▶ PnP/PCI Configurations ▶ PC Health Status 	<ul style="list-style-type: none"> ▶ Frequency Control Load Fail-Safe Defaults Load Optimized Defaults Set Supervisor Password Set User Password Save & Exit Setup Exit Without Saving
Esc : Quit F10 : Save & Exit Setup	↑↓→← : Select Item
Time, Date, Hard Disk Type	

Setup program initial screen

You may use the cursor the up/down keys to highlight the individual menu items. As you highlight each item, a brief description of the highlighted selection will appear at the bottom of the screen.

4-3. THE STANDARD CMOS FEATURES

Highlight the "STANDARD CMOS FEATURES" and press the <ENTER> key and the screen will display the following table:

Phoenix - AwardBIOS CMOS Setup Utility
Standard CMOS Features

Date (mm:dd:yy)	Fri, Aug 6 2004	Item Help
Time (hh:mm:ss)	16 : 10 : 24	
▶ IDE Primary Master	[None]	Menu Level ▶
▶ IDE Primary Slave	[None]	Change the internal clock.
▶ IDE Secondary Master	[None]	
▶ IDE Secondary Slave	[None]	
Drive A	[1.44M, 3.5 in.]	
Drive B	[None]	
Video	[EGA/VGA]	
Halt On	[All, But Keyboard]	
Base Memory	640K	
Extended Memory	1276928K	
Total Memory	1277952K	
↑↓→←: Move Enter: Select +/-/PU/PD:Value F10:Save ESC:Exit F1:General Help F5: Previous Values F6: Fail-Safe Defaults F7:Optimized Defaults		

CMOS Setup screen

In the above Setup Menu, use the arrow keys to highlight the item and then use the <PgUp> or <PgDn> keys to select the value you want in each item.

Date:

< Month >, < Date > and <Year >. Ranges for each value are in the CMOS Setup Screen, and the week-day will skip automatically.

Time:

< Hour >, < Minute >, and < Second >. Use 24 hour clock format, i.e., for PM numbers, add 12 to the hour. For example: 4: 30 P.M. You should enter the time as 16:30:00.

IDE Primary Master / Slave:

IDE Secondary Master / Slave:

The BIOS can automatically detect the specifications and optimal operating mode of almost all IDE hard drives. When you select type AUTO for a hard drive, the BIOS detect its specifications during POST, every time system boots.

If you do not want to select drive type AUTO, other methods of selecting drive type are available:

1. Match the specifications of your installed IDE hard drive(s) with the preprogrammed values for hard drive types 1 through 45.
2. Select USER and enter values into each drive parameter field.
3. Use the IDE HDD AUTO DETECTION function in Setup.

Here is a brief explanation of drive specifications:

Type: The BIOS contains a table of pre-defined drive types. Each defined drive type has a specified number of cylinders, number of heads, write precompensation factor, landing zone, and number of sectors. Drives whose specifications do not accommodate any predefine type are classified as type USER.

- Size: Disk drive capacity (approximate). Note that this size is usually greater than the size of a formatted disk given by a disk-checking program.
- Cyls: number of cylinders.
- Head: number of heads.
- Precomp: write precompensation cylinders.
- Landz: landing zone.
- Sector: number of sectors.
- Mode: Auto, Normal, Large or LBA.

Auto: The BIOS automatically determines the optimal mode.

- Normal: Maximum number of cylinders, heads, sectors supported are 1024, 16 and 63.
- Large: For drives that do not support LBA and have more than 1024 cylinders.

- LBA (Logical Block Addressing): During drive accesses, the IDE controller transforms the data address described by sector, head and cylinder number into a physical block address, significantly improving data transfer rates. For drives greater than 1024 cylinders.

DRIVE A AND DRIVE B:

Select the type of floppy disk drive installed in your system. The available options are 360KB 5.25in, 1.2KB 5.25in, 720KB 3.5in, 1.44MB 3.5in, 2.88MB 3.5in and None.

VIDEO:

This category selects the type of video adapter used for the primary system monitor. Although secondary monitors are supported, you do not have to select the type in Setup. Available Options are as follows:

EGA/VGA	Enhanced Graphics Adapter/Video Graphics Array. For EGA, VGA, SEGA, SVGA or PGA monitor adapters.
CGA 40	Color Graphics Adapter, power up in 40 column mode.
CGA 80	Color Graphics Adapter, power up in 80 column mode.
MONO	Monochrome adapter, includes high resolution monochrome adapters.

HALT ON:

This category allows user to choose whether the computer will stop if an error is detected during power up. Available options are “All errors”, “No errors”, “All, But keyboard”, “All, But Diskette”, and “All But Disk/Key”.

BASE MEMORY:

Displays the amount of conventional memory detected during boot up.

EXTENDED MEMORY:

Displays the amount of extended memory detected during boot up.

TOTAL MEMORY:

Displays the total memory available in the system.

HARD DISK ATTRIBUTES:

Type	Cylinders	Heads	V-P comp	LZone	Sect	Capacity
1	306	4	128	305	17	10
2	615	4	300	615	17	20
3	615	6	300	615	17	30
4	940	8	512	940	17	62
5	940	6	512	940	17	46
6	615	4	65535	615	17	20
7	642	8	256	511	17	30
8	733	5	65535	733	17	30
9	900	15	65535	901	17	112
10	820	3	65535	820	17	20
11	855	5	65535	855	17	35
12	855	7	65535	855	17	49
13	306	8	128	319	17	20
14	733	7	65535	733	17	42
15	000	0	0000	000	00	00
16	612	4	0000	663	17	20
17	977	5	300	977	17	40
18	977	7	65535	977	17	56
19	1024	7	512	1023	17	59
20	733	5	300	732	17	30
21	733	7	300	732	17	42
22	733	5	300	733	17	30
23	306	4	0000	336	17	10
24	977	5	65535	976	17	40
25	1024	9	65535	1023	17	76
26	1224	7	65535	1223	17	71
27	1224	11	65535	1223	17	111
28	1224	15	65535	1223	17	152
29	1024	8	65535	1023	17	68
30	1024	11	65535	1023	17	93
31	918	11	65535	1023	17	83
32	925	9	65535	926	17	69
33	1024	10	65535	1023	17	85
34	1024	12	65535	1023	17	102
35	1024	13	65535	1023	17	110
36	1024	14	65535	1023	17	119
37	1024	2	65535	1023	17	17
38	1024	16	65535	1023	17	136
39	918	15	65535	1023	17	114
40	820	6	65535	820	17	40
41	1024	5	65535	1023	17	42
42	1024	5	65535	1023	26	65
43	809	6	65535	852	17	40
44	809	6	65535	852	26	61
45	776	8	65335	775	33	100
47			AUTO			

Award Hard Disk Type Table

4-4. THE ADVANCED BIOS FEATURES

Choose the "ADVANCED BIOS FEATURES" in the main menu, the screen shown as below.

Phoenix - AwardBIOS CMOS Setup Utility
Advanced BIOS Features

Virus Warning	[Disabled]	Item Help	
CPU L1 & L2 Cache	[Enabled]		
Quick Power On Self Test	[Enabled]	Menu Level ► Allows you to choose the VIRUS warning feature for IDE Hard Disk boot sector protection. If this function is enabled and someone attempt to write data into this area, BIOS will show a warning message on screen and alarm beep	
First Boot Device	[Floppy]		
Second Boot Device	[HDD-0]		
Boot Up Floppy Seek	[Enabled]		
Boot Up NumLock Status	[On]		
Typematic Rate Setting	[Disabled]		
x Typematic Rate (Chars/Sec)	6		
x Typematic Delay (Msec)	250		
Security Option	[Setup]		
OS Select For DRAM > 64MB	[Non-OS2]		
↑↓→←: Move Enter: Select +/-/PU/PD:Value F10:Save ESC:Exit F1:General Help F5: Previous Values F6: Fail-Safe Defaults F7:Optimized Defaults			

BIOS Features Setup Screen

The "BIOS FEATURES SETUP" allow you to configure your system for basic operation. The user can select the system's default speed, boot-up sequence, keyboard operation, shadowing and security.

A brief introduction of each setting is given below.

VIRUS WARNING :

This item allows you to choose the Virus Warning feature for IDE Hard Disk boot sector protection. If this function is enabled and someone attempt to write data into this area, BIOS will show a warning message on screen and alarm beep.

CPU L1 & L2 CACHE :

This item allows you to enable L1 & L2 cache.

QUICK POWER ON SELF-TEST:

This item allows you to speed up Power On Self Test (POST) after power-up the computer. When enabled, the BIOS will shorten or skip some check items during POST.

FIRST/SECOND/ BOOT DEVICE:

The BIOS attempt to load the operating system from the devices in the sequence selected in these items.

BOOT UP FLOPPY SEEK:

You may enable / disable this item to define whether the system will look for a floppy disk drive to boot at power-on, or proceed directly to the hard disk drive.

BOOT UP NUMLOCK STATUS:

Select power on state for NumLock.

TYPOMATIC RATE SETTING:

Enable this item if you wish to be able to configure the characteristics of your keyboard. Typematic refers to the way in which characters are entered repeatedly if a key is held down. For example, if you press and hold down the "A" key, the letter "a" will repeatedly appear on your screen on your screen until you release the key. When enabled, the typematic rate and typematic delay can be selected.

TYPOMATIC RATE (CHARS/SEC):

This item sets the number of times a second to repeat a key stroke when you hold the key down.

TYPOMATIC DELAY (MSEC):

The item sets the delay time after the key is held down before it begins to repeat the keystroke.

SECURITY OPTION:

This category allows you to limit access to the system and Setup, or just to Setup.

System	The system will not boot and access to Setup will be denied if the correct password is not entered at the prompt.
Setup	The system will boot, but access to Setup will be denied if the correct password is not entered at the prompt.

 To disable security, select PASSWORD SETTING at Main Menu and then you will be asked to enter password. Do not type anything and just press <Enter>, it will disable security. Once the security is disabled, the system will boot and you can enter Setup freely.

OS SELECT FOR DRAM >64MB :

Select the operating system that is running with greater than 64MB or RAM on the system. You may choose OS2 or Non-OS2.

4-5. ADVANCED CHIPSET FEATURES

Choose the "ADVANCED CHIPSET FEATURES" from the main menu, the screen shown as below.

Phoenix - AwardBIOS CMOS Setup Utility		
Advanced Chipset Features		
		Item Help
DRAM Timing Selectable	[By SPD]	
X CAS Latency Time	2.5	
X Active to Precharge Delay	7	
X DRAM RAS# to CAS# Delay	3	
X DRAM RAS# Precharge	3	Menu Level ►
DRAM Data Integrity Mode	Non-ECC	
System BIOS Cacheable	[Enabled]	
Video BIOS Cacheable	[Disabled]	
Memory Hole At 15M-16M	[Disabled]	
Delayed Transaction	[Enabled]	
AGP Aperture Size (MB)	[64]	
** On-Chip VGA Setting **		
On-Chip VGA	[Enabled]	
On-Chip Frame Buffer Size	[32MB]	
Boot Display	[CRT]	
Panel Type	[640x480 18-bits]	
PCI SERR# NMI	[Disabled]	
↑↓→←: Move Enter: Select +/-/PU/PD:Value F10:Save ESC:Exit F1:General Help F5: Previous Values F6: Fail-Safe Defaults F7:Optimized Defaults		

Chipset Features Setup Screen

This parameter allows you to configure the system based on the specific features of the installed chipset. The chipset manages bus speed and access to system memory resources, such as DRAM and the external cache.

It also coordinates communications between conventional ISA bus and the PCI bus. It must be stated that these items should never need to be altered. The default settings have been chosen because they provide the best operating conditions for the system. The only time you might consider making any changes would be if you discovered that data was being lost while using your system.

DRAM TIMING BY SELECTABLE:

This allows you to select the DRAM timing.

CAS LATENCY TIME:

When synchronous DRAM is installed, the number of clock cycles of CAS latency depends on the DRAM timing.

ACTIVE TO PRECHARGE DELAY:

This item controls the number of DRAM clocks for TRAS.

DRAM RAS# TO CAS# DELAY:

This field let's you insert a timing delay between the CAS and RAS strobe signals, used when DRAM is written to, read from, or refreshed. Fast gives faster performance; and Slow gives more stable performance. This field applies only when synchronous DRAM is installed in the system.

DRAM RAS# PRECHARGE:

If an insufficient number of cycles is allowed for the RAS to accumulate its charge before DRAM refresh, the refresh may be incomplete and the DRAM may fail to retain data. Fast gives faster performance; and Slow gives more stable performance. This field applies only when synchronous DRAM is installed in the system.

DRAM DATA INTEGRITY MODE:

Select Parity or ECC (error-correcting code), according to the type of installed DRAM.

SYSTEM BIOS CACHEABLE:

Selecting Enabled allows caching of the system BIOS ROM at F0000h-FFFFFh, resulting in better system performance. However, if any program writes to this memory area, a system error may result.

VIDEO BIOS CACHEABLE:

Select Enabled allows caching of the video BIOS, resulting in better system performance. However, if any program writes to this memory area, a system error may result.

MEMORY HOLE AT 15M-16M:

You can reserve this area of system memory for ISA adapter ROM. When this area is reserved, it cannot be cached. The user information of peripherals that need to use this area of system memory usually discusses their memory requirements.

DELAYED TRANSACTION:

The chipset has an embedded 32-bit posted write buffer to support delay transactions cycles. Select Enabled to support compliance with PCI specification version 2.1.

AGP APERTURE SIZE:

This field determines the effective size of the Graphic Aperture used for a particular GMCH configuration. It can be updated by the GMCH-specific BIOS configuration sequence before the PCI standard bus enumeration sequence takes place. If it is not updated then a default value will select an aperture of maximum size.

4-6. INTEGRATED PERIPHERALS

Choose "INTEGRATED PERIPHERALS" from the main setup menu, a display will be shown on screen as below:

Phoenix - AwardBIOS CMOS Setup Utility
Integrated Peripherals

OnChip IDE Device	[Press Enter]	Item Help
Onboard Device	[Press Enter]	
SuperIO Device	[Press Enter]	Menu Level ▶
Watch Dog Timer Select	[Disabled]	
Onboard Serial Port 3	[3E8]	
Serial Port 3 Use IRQ	[IRQ10]	
Onboard Serial Port 4	[2E8]	
Serial Port 4 Use IRQ	[IRQ11]	
↑↓→←: Move Enter: Select +/-/PU/PD:Value F10:Save ESC:Exit F1:General Help F5: Previous Values F6: Fail-Safe Defaults F7:Optimized Defaults		

Integrated Peripherals Setup Screen

By moving the cursor to the desired selection and by pressing the <F1> key, the all options for the desired selection will be displayed for choice.

- ⚠ If bios setup menu item supports USB device boot, it will cause Win9x detects the same storages twice when the system is rebooted, and USB HDD will fail. Note: this cause just happen under Win9x, the phenomenon is a limitation.

ONCHIP IDE DEVICE:

The options for these items are found in its sub menu. By pressing the <ENTER> key, you are prompt to enter the sub menu of the detailed options as shown below:

Phoenix – Award CMOS Setup Utility
OnChip IDE Device

OnChip Primary PCI IDE	[Enabled]	Item Help
IDE Primary Master PIO	[Auto]	Menu Level ►
IDE Primary Slave PIO	[Auto]	
IDE Primary Master UDMA	[Auto]	
IDE Primary Slave UDMA	[Auto]	
OnChip Secondary PCI IDE	[Enabled]	
IDE Secondary Master PIO	[Auto]	
IDE Secondary Slave PIO	[Auto]	
IDE Secondary Master UDMA	[Auto]	
IDE Secondary Slave UDMA	[Auto]	
IDE HDD Block Mode	[Enabled]	
↑↓→←:Move Enter: Select +/-/PU/PD:Value F10:Save ESC:Exit F1:General Help F5: Previous Values F6:Fail-Safe Defaults F7:Optimized Defaults		

Descriptions on each item above are as follows:

1. OnChip Primary PCI IDE

The integrated peripheral controller contains an IDE interface with support for two IDE channels. Select Enabled to activate each channel separately.

**2. Primary Master/Slave PIO
Secondary Master/Slave PIO**

The four IDE PIO fields allow you to set a PIO mode (0-4) for each of the four IDE devices that the onboard IDE interface supports. Modes 0 through 4 provide successively increased performance. In Auto mode, the system automatically determines the best mode for each device.

**3. Primary Master/Slave UDMA
Secondary Master/Slave UDMA**

Ultra DMA/33 implementation is possible only if your IDE hard drive supports it and the operating environment includes a DMA driver (Windows 95 OSR2 or a third-party IDE bus master driver). If you

hard drive and your system software both support Ultra DMA/33, select Auto to enable BIOS support.

4. IDE HDD Block Mode

Block mode is also called block transfer, multiple commands, or multiple sector read/write. If your IDE hard drive supports block mode (most new drives do), select Enabled for automatic detection of the optimal number of block read/writes per sector the drive can support.

ONBOARD DEVICE:

The options for these items are found in its sub menu. By pressing the <ENTER> key, you are prompt to enter the sub menu of the detailed options as shown below:

Phoenix – Award CMOS Setup Utility
Onboard Device

USB Controller	[Enabled]	Item Help
USB 2.0 Support	[Enabled]	
USB Keyboard Support	[Disabled]	Menu Level ►
USB Mouse Support	[Disabled]	
AC97 Audio	[Auto]	
Onboard LAN	[Enabled]	
Init Display First	[Onboard]	
↑↓→←:Move Enter:Select +/-/PU/PD:Value F10:Save ESC:Exit F1:General Help F5: Previous Values F6:Fail-Safe Defaults F7:Optimized Defaults		

Descriptions on each item above are as follows:

1. USB Controller

This should be enabled if your system has a USB installed on the system board and you want to use it. Even when so equipped, if you add a higher performance controller, you will need to disable this feature.

2. USB Keyboard Support

Select Enabled if your system contains a Universal Serial Bus (USB) controller and you have a USB keyboard.

3. USB Mouse Support

Select Enabled if your system contains a Universal Serial Bus (USB) controller and you have a USB Mouse.

4. AC97 Audio

This item allows you to enable/disable to support AC97 Audio.

5. Init Display First

This item allows you to decide to active whether PCI Slot or on-chip VGA first.

SUPER IO DEVICE:

The options for these items are found in its sub menu. By pressing the <ENTER> key, you are prompt to enter the sub menu of the detailed options as shown below:

Phoenix – Award CMOS Setup Utility
SuperIO Device

Onboard FDC Controller	[Enabled]	Item Help
Onboard Serial Port 1	[3F8/IRQ4]	
Onboard Serial Port 2	[2F8/IRQ3]	Menu Level ►
UART Mode Select	[Normal]	
X RxD, TxD Active	Hi, Lo	
X IR Transmission Delay	Enabled	
X UR2 Duplex Mode	Half	
X Use IR Pins	IR-Rx2Tx2	
Onboard Parallel Port	[378/IRQ7]	
Parallel Port Mode	[SPP]	
X EPP Mode Select	EPP1.7	
X ECP Mode Use DMA	3	
PWRON After PWR-Fail	[Off]	
↑↓→←:Move Enter: Select +/-/PU/PD:Value F10:Save ESC:Exit F1:General Help F5: Previous Values F6:Fail-Safe Defaults F7:Optimized Defaults		

Descriptions on each item above are as follows:

1. Onboard FDC Controller

Select Enabled if the system has a floppy disk controller (FDC) installed on the system board and you wish to use it. If you install and-in FDC or the system has no floppy drive, select Disabled.

2. Onboard Serial Port 1/2

Select an address and corresponding interrupt for the first and second serial ports.

3. UART Mode Select

This item allows you to select UART mode.

4. RxD, TxD Active

This item allows you to determine the active of RxD, TxD.

- 5. IR Transmission Delay**
This item allows you to enable/disable IR transmission delay.
- 6. UR2 Duplex Mode**
This item allows you to select the IR half/full duplex function.
- 7. Use IR Pins**
This item allows you to select IR transmission routes, one is RxD2m, TxD2 (COM Port) and the other is IR-Rx2Tx2
- 8. Onboard Parallel Port**
This item allows you to determine access onboard parallel port controller with which I/O address.
- 9. Parallel Port Mode**
Select an operating mode for the onboard parallel (printer) port. Select *Normal*, *Compatible*, or *SPP* unless you are certain your hardware and software both support one of the other available modes.
- 10. EPP Mode Select**
Select EPP port type 1.7 or 1.9.
- 11. ECP Mode Use DMA**
Select a DMA channel for the parallel port for use during ECP mode.
- 12. PWRON After PWR-Fail**
This item allows you to select if you want to power on the system after power failure. The choice: Off, On, Former-Sts.

ONBOARD SERIAL PORT 3/4:

Select a logical COM port name and matching address for the first and second serial ports. Select an address and corresponding interrupt for the first and second serial ports.

4-7. POWER MANAGEMENT SETUP

Choose "POWER MANAGEMENT SETUP" option on the main menu, a display will be shown on screen as below :

Phoenix - AwardBIOS CMOS Setup Utility
Power Management Setup

ACPI Function	[Enabled]	Item Help
Power Management	[User Define]	
Video Off Method	[DPMS]	Menu Level ►
Video Off In Suspend	[Yes]	
MODEM Use IRQ	[3]	
Suspend Mode	[Disabled]	
Power-Supply Type	[ATX]	
Soft-Off by PWR-BTTN	[Instant-Off]	
Wake-Up by PCI card	[Enabled]	
Wake-Up On LAN	[Enabled]	
Resume by Alarm	[Disabled]	
x Date (of Month) Alarm	0	
x Time (hh:mm:ss) Alarm	0 : 0 : 0	
** Reload Global Timer Events **		
Primary IDE 0	[Disabled]	
Primary IDE 1	[Disabled]	
Secondary IDE 0	[Disabled]	
Secondary IDE 1	[Disabled]	
FDD, COM, LPT Port	[Disabled]	
↑↓→←: Move Enter: Select +/-/PU/PD:Value F10:Save ESC:Exit F1:General Help F5: Previous Values F6: Fail-Safe Defaults F7:Optimized Defaults		

Power Management Setup Screen

The "Power Management Setup" allows the user to configure the system to the most effectively save energy while operating in a manner consistent with your own style of computer use.

ACPI SUSPEND TYPE:

This item allows the user to set the ACPI suspend type to be used.

POWER MANAGEMENT:

This item allows you to select the Power Management mode.

VIDEO OFF OPTION:

When enabled, this feature allows the VGA adapter to operate in a power saving mode.

Always On	Monitor will remain on during power saving modes.
Suspend --> Off	Monitor blanked when the systems enters the Suspend mode.
Susp,Stby --> Off	Monitor blanked when the system enters either Suspend or Standby modes.
All Modes --> Off	Monitor blanked when the system enters any power saving mode.

VIDEO OFF METHOD:

This determines the manner in which the monitor is blanked.

V/H SYNC+Blank	This selection will cause the system to turn off the vertical and horizontal synchronization ports and write blanks to the video buffer.
Blank Screen	This option only writes blanks to the video buffer.
DPMS	Select this option if your monitor supports the Display Power Management Signalling (DPMS) standard of the Video Electronics Standards to select video power management values.

MODEM USE IRQ:

This item enable you to name the interrupt request (IRQ) line assigned to the modem (if any) on your system. Activity of the selected IRQ always awakens the system.

SUSPEND MODE:

When enabled and after the set time of system inactivity, all devices except the CPU will be shut off.

SOFT-OFF BY PWR-BTTN:

Pressing the power button for more than 4 seconds forces the system to enter the Soft-Off state when the system has "hung". The choices are Delay 4 Sec and Instant-Off.

WAKE-UP BY PCI CARD:

An input signal from PME on the PCI card awakens the system from a soft off state.

RESUME BY ALARM:

When *Enabled*, you can set the date and time at which the RTC (real-time clock) alarm awakens the system from Suspend mode.

PM EVENTS:

PM events are I/O events whose occurrence can prevent the system from entering a power saving mode or can awaken the system from such a mode. In effect, the system remains alert for anything, which occurs to a device which is configured as *Enabled*, even when the system is in a power down mode. (1) **Primary IDE 0** (2) **Primary IDE 1** (3) **Secondary IDE 0** (4) **Secondary IDE 1** (5) **FDD, COM, LPT Port**

4-8. PNP/PCI CONFIGURATION

Choose "PNP/PCI CONFIGURATION" from the main menu, a display will be shown on screen as below:

Phoenix - AwardBIOS CMOS Setup Utility
PnP/PCI Configurations

Reset Configuration Data	[Disabled]	Item Help
Resources Controlled By x IRQ Resources	[Auto (ESCD)] Press Enter	Menu Level ►
PCI/VGA Palette Snoop	[Disabled]	Select Yes if you are using a Plug and Play capable operating system Select No if you need the BIOS to configure non-boot devices
↑↓→←: Move Enter: Select +/-/PU/PD:Value F10:Save ESC:Exit F1:General Help F5: Previous Values F6: Fail-Safe Defaults F7:Optimized Defaults		

PNP/PCI Configuration Setup Screen

The PNP/PCI Configuration Setup describes how to configure PCI bus system. PCI, also known as Personal Computer Interconnect, is a system, which allows I/O devices to operate at speeds nearing the speed of the CPU itself uses when communicating with its own special components.

This section covers technical items, which is strongly recommended for experienced users only.

RESET CONFIGURATION DATA:

Normally, you leave this field Disabled. Select Enabled to reset Extended System Configuration Data (ESCD) when you exit Setup if you have installed a new add-on and the system configuration has caused such a serious conflict that the operating system cannot boot.

RESOURCE CONTROLLED BY:

The Award Plug and Play Bios can automatically configure all of the booth and Plug and Play-compatible devices. However, this capability means absolutely nothing unless you are using a Plug and Play operating system such as Windows 95. By choosing “manual”, you are allowed to configure the *IRQ Resources and DMA Resources*.

IRQ RESOURCES:

The options for these items are found in its sub menu. By pressing the <ENTER> key, you are prompt to enter the sub menu of the detailed options as shown below:

Phoenix – Award CMOS Setup Utility
IRQ Resources

IRQ-3 assigned to	[PCI Device]	Item Help	
IRQ-4 assigned to	[PCI Device]		
IRQ-5 assigned to	[PCI Device]	Menu Level ► Legacy ISA for devices compliant with the original PC AT bus specification, PCI/ISA PnP for devices compliant with the Plug and Play standard whether designed for PCI or ISA bus architecture	
IRQ-7 assigned to	[PCI Device]		
IRQ-9 assigned to	[PCI Device]		
IRQ-10 assigned to	[PCI Device]		
IRQ-11 assigned to	[PCI Device]		
IRQ-12 assigned to	[PCI Device]		
IRQ-14 assigned to	[PCI Device]		
IRQ-15 assigned to	[PCI Device]		
↑↓→←:Move Enter: Select +/-/PU/PD:Value F10:Save ESC:Exit F1:General Help F5: Previous Values F6:Fail-Safe Defaults F7:Optimized Defaults			

Descriptions on each item above are as follows:

13. IRQ-n Assigned to:

You may assign each system interrupt a type, depending on the type of device using the interrupt.

4-9. PC HEALTH STATUS

Choose "PC HEALTH STATUS" from the main menu, a display will be shown on screen as below:

Phoenix - AwardBIOS CMOS Setup Utility
PC Health Status

Current Warning Temperature	[Disabled]	Item Help
Current CPU Temperature	42 /107	Menu Level ►
Current CPU Fan Speed	5273 RPM	
Current SYSTEM Fan Speed	0 RPM	
Vcore	1.47V	
Vccp	1.48V	
3.3 V	3.26V	
+ 5 V	5.05V	
+12 V	11.97V	
-12 V	-12.52V	
- 5 V	0.00V	
VBAT (V)	3.20V	
5VSB (V)	4.96V	
Shutdown Temperature	[Disabled]	
↑↓→←: Move Enter: Select +/-/PU/PD:Value F10:Save ESC:Exit F1:General Help F5: Previous Values F6: Fail-Safe Defaults F7:Optimized Defaults		

PC Health Status Setup Screen

The PC Health Status Setup allows you to select whether to choose between monitoring or to ignore the hardware monitoring function of your system.

CURRENT WARNING TEMPERATURE:

Select the combination of lower and upper limits for the CPU temperature. If the CPU temperature extends beyond either limit, any warning mechanism programmed into your system will be activated.

CURRENT CPU TEMPERATURE:

This item shows you the current CPU temperature.

CURRENT CPU FAN SPEED:

This item shows you the current CPUFAN speed.

CURRENT SYSTEM FAN SPEED:

This item shows you the current System FAN speed.

VCORE:

This item shows you the current system voltage.

3.3V / +5V / +12V / -12V / -5V:

Show you the voltage of 3.3V/+5V/+12V/-12V/-5V.

SHUTDOWN TEMPERATURE:

This item allows you to set up the CPU shutdown Temperature. This function is only effective under Windows 98 ACPI mode.

4-10. FREQUENCY CONTROL

Choose "FREQUENCY CONTROL" from the main menu, a display will be shown on screen as below:

Phoenix - AwardBIOS CMOS Setup Utility
Frequency Control

Auto Detect PCI Clk	[Enabled]	Item Help
Spread Spectrum	[Enabled]	
		Menu Level ►
↑↓→←: Move Enter: Select +/-/PU/PD: Value F10: Save ESC: Exit F1: General Help F5: Previous Values F6: Fail-Safe Defaults F7: Optimized Defaults		

Frequency Control Setup Screen

This setup menu allows you to specify your settings for frequency control.

AUTO DETECT PCI CLK:

This item allows you to enable or disable auto detect PCI Clock.

SPREAD SPECTRUM:

When the system clock generator pulses, the extreme values of the pulse generate excess EMI. Enabling pulse spectrum spread modulation changes the extreme values from spikes to flat curves, thus reducing EMI. This benefit may in some cases be outweighed by problems with timing-critical devices such as a clock-sensitive SCSI device.

4-11. LOAD FAIL-SAFE DEFAULTS

By pressing the <ENTER> key on this item, you get a confirmation dialog box with a message similar to the following:

Load Fail-Safe Defaults (Y/N) ? N

To use the BIOS default values, change the prompt to "Y" and press the <Enter > key. CMOS is loaded automatically when you power up the system.

4-12. LOAD OPTIMIZED DEFAULTS

When you press <Enter> on this category, you get a confirmation dialog box with a message similar to the following:

Load Optimized Defaults (Y/N) ? N

Pressing "Y" loads the default values that are factory setting for optimal performance system operations.

4-13. PASSWORD SETTING

User is allowed to set either supervisor or user password, or both of them. The difference is that the supervisor password can enter and change the options of the setup menus while the user password can enter only but do not have the authority to change the options of the setup menus.

TO SET A PASSWORD

When you select this function, the following message will appear at the center of the screen to assist you in creating a password.

Enter Password:

Type the password up to eight characters in length, and press < Enter >. The password typed now will clear any previously entered password from CMOS memory. You will be asked to confirm the password. Type the password again and press the < Enter > key. You may also press < Esc > to abort the selection and not enter a password.

 User should bear in mind that when a password is set, you will be asked to enter the password everything you enter CMOS setup Menu.

TO DISABLE THE PASSWORD

To disable the password, select this function (do not enter any key when you are prompt to enter a password), and press the <Enter> key and a message will appear at the center of the screen:

PASSWORD DISABLED!!!
Press any key to continue...

Press the < Enter > key again and the password will be disabled. Once the password is disabled, you can enter Setup freely.

4-14. SAVE & EXIT SETUP

After you have completed adjusting all the settings as required, you must remember to save these setting into the CMOS RAM. To save the settings, select "SAVE & EXIT SETUP" and press <Enter>, a display will be shown as follows:

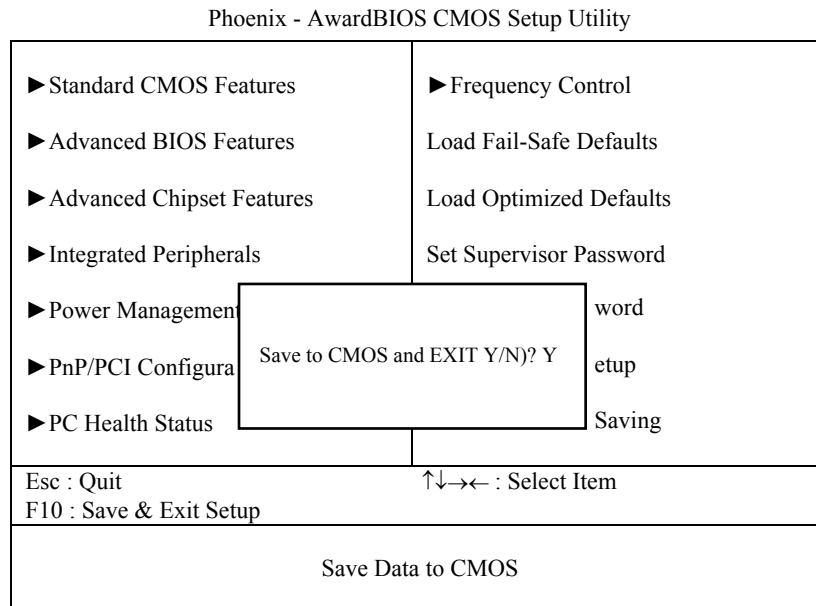

When you confirm that you wish to save the settings, your system will be automatically restarted and the changes you have made will be implemented. You may always call up the setup program at any time to adjust any of the individual items by pressing the key during boot up.

EXPANSION BUS

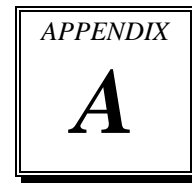

This appendix indicates the pin assignments.

Section includes:

- PCI BUS Pin Assignment
- EPCI BUS Pin Assignment
- Compact Flash Card Connector Pin Assignment

PCI BUS PIN ASSIGNMENT

Like ISA-BUS connector, the PCI-BUS edge connector is also divided into two sets: one consists of 98-pin; the other consists of 22-pin. The pin assignments are as follows :

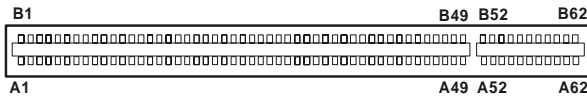

B		A		B		A	
PIN	ASSIGNMENT	PIN	ASSIGNMENT	PIN	ASSIGNMENT	PIN	ASSIGNMENT
B1	-12V	A1	TRST#	B31	+3.3V	A31	AD18
B2	TCK	A2	+12V	B32	AD17	A32	AD16
B3	GND	A3	TMS	B33	C/BE2#	A33	+3.3V
B4	TDO	A4	TDI	B34	GND	A34	FRAME#
B5	+5V	A5	+5V	B35	IRDY#	A35	GND
B6	+5V	A6	INTA#	B36	+3.3V	A36	TRDY#
B7	INTB#	A7	INTC#	B37	DEVSEL#	A37	GND
B8	INTD#	A8	+5V	B38	GND	A38	STOP#
B9	REQ3#	A9	CLKC	B39	LOCK#	A39	+3.3V
B10	REQ1#	A10	+5V(I/O)	B40	PERR#	A40	SDONE
B11	GNT3#	A11	CLKD	B41	+3.3V	A41	SB0#
B12	GND	A12	GND	B42	SERR#	A42	GND
B13	GND	A13	GND	B43	+3.3V	A43	PAR
B14	CLKA	A14	GNT1#	B44	C/BE1#	A44	AD15
B15	GND	A15	RST#	B45	AD14	A45	+3.3V
B16	CLKB	A16	+5V(I/O)	B46	GND	A46	AD13
B17	GND	A17	GNT0#	B47	AD12	A47	AD11
B18	REQ0#	A18	GND	B48	AD10	A48	GND
B19	+5V(I/O)	A19	REQ2#	B49	GND	A49	AD09
B20	AD31	A20	AD30	B52	AD08	A52	C/BE0#
B21	AD29	A21	+3.3V	B53	AD07	A53	+3.3V
B22	GND	A22	AD28	B54	+3.3V	A54	AD06
B23	AD27	A23	AD26	B55	AD05	A55	AD04
B24	AD25	A24	GND	B56	AD03	A56	GND
B25	+3.3V	A25	AD24	B57	GND	A57	AD02
B26	C/BE3#	A26	GNT2#	B58	AD01	A58	AD00
B27	AD23	A27	+3.3V	B59	+5V(I/O)	A59	+5V(I/O)
B28	GND	A28	AD22	B60	ACK64#	A60	REQ64#
B29	AD21	A29	AD20	B61	+5V	A61	+5V
B30	AD19	A30	GND	B62	+5V	A62	+5V

EPCI CONNECTOR

You will find a EPCI connector in our EBC-I855C.
The pin assignments are as follows:



EPCI1

PIN	ASSIGNMENT	PIN	ASSIGNMENT
A1	GND	B1	GND
A2	AD0	B2	AD1
A3	AD2	B3	AD3
A4	AD4	B4	AD5
A5	AD6	B5	AD7
A6	AD8	B6	AD9
A7	AD10	B7	AD11
A8	VCC	B8	VCC
A9	AD12	B9	AD13
A10	AD14	B10	AD15
A11	AD16	B11	AD17
A12	AD18	B12	AD19
A13	AD20	B13	AD21
A14	AD22	B14	AD23
A15	VCC	B15	VCC
A16	AD24	B16	AD25
A17	AD26	B17	AD27
A18	AD28	B18	AD29
A19	AD30	B19	AD31
A20	PIRQ#B	B20	PAR
A21	PP CLK	B21	IRDY#
A22	ID SEL	B22	TRDY#
A23	CBE#0	B23	CBE#1
A24	CBE#2	B24	CBE#3
A25	PGNT#4	B25	PREQ#4
A26	SERR#	B26	PERR#
A27	PIRQ#A	B27	PCI_RST#
A28	STOP#	B28	PLOCK#
A29	DEVSEL#	B29	FRAME#
A30	GND	B30	GND

• The EPCI expansion connector of this Card is designed based on PCI Bus Master.

COMPACT FLASH CARD CONNECTOR PIN ASSIGNMENT

The pin assignments of Compact Flash Card connector are stated below.

PIN	ASSIGNMENT	PIN	Assignment
1	GND	26	-CD1
2	D03	27	D111
3	D04	28	D121
4	D05	29	D131
5	D06	30	D141
6	D07	31	D151
7	-CS0	32	-CS11
8	A102	33	-VS1
9	-ATASEL	34	-IORD
10	A092	35	-IOWR
11	A082	36	-WE3
12	+3.3V	37	INTRQ
13	VCC	38	VCC
14	A062	39	-CSEL
15	A052	40	-VS2
16	A042	41	-RESET
17	A032	42	IORDY
18	A02	43	-INPACK
19	A01	44	-REG3
20	A00	45	-DASP
21	D00	46	-PDIAG
22	D01	47	D081
23	D02	48	D091
24	-IOCS16	49	D101
25	-CD2	50	GND

TECHNICAL SUMMARY

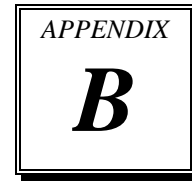

This section introduce you the maps concisely.

Section includes:

- Block Diagram
- Interrupt Map
- RTC & CMOS RAM Map
- Timer & DMA Channels Map
- I / O & Memory Map

BLOCK DIAGRAM

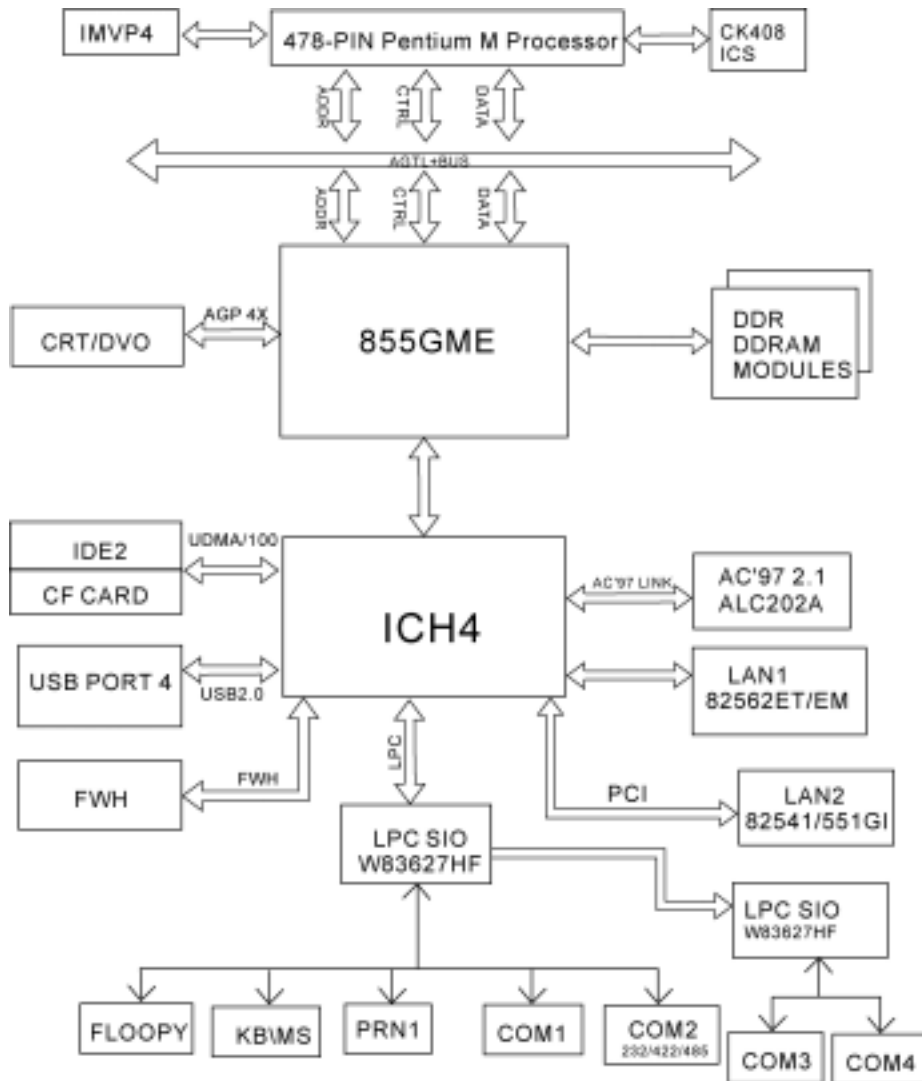

INTERRUPT MAP

IRQ	ASSIGNMENT
0	System TIMER
1	Keyboard
2	Cascade
3	Serial port 2
4	Serial port 1
5	Available
6	Floppy
7	Parallel port 1
8	RTC clock
9	Available
10	Available
11	Available
12	PS/2 Mouse
13	Math coprocessor
14	IDE1
15	IDE2

RTC & CMOS RAM MAP

CODE	ASSIGNMENT
00	Seconds
01	Second alarm
02	Minutes
03	Minutes alarm
04	Hours
05	Hours alarm
06	Day of week
07	Day of month
08	Month
09	Year
0A	Status register A
0B	Status register B
0C	Status register C
0D	Status register D
0E	Diagnostic status byte
0F	Shutdown byte
10	Floppy Disk drive type byte
11	Reserve
12	Hard Disk type byte
13	Reserve
14	Equipment byte
15	Base memory low byte
16	Base memory high byte
17	Extension memory low byte
18	Extension memory high byte
30	Reserved for extension memory low byte
31	Reserved for extension memory high byte
32	Date Century byte
33	Information Flag
34-3F	Reserve
40-7f	Reserved for Chipset Setting Data

TIMER & DMA CHANNELS MAP

Timer Channel Map :

Timer Channel	Assignment
0	System timer interrupt
1	DRAM Refresh request
2	Speaker tone generator

DMA Channel Map :

DMA Channel	Assignment
0	Available
1	Available
2	Floppy
3	Available
4	Cascade
5	Available
6	Available
7	Available

I/O & MEMORY MAP

Memory Map :

MEMORY MAP	ASSIGNMENT
0000000-009FFFF	System memory used by DOS and application
00A0000-00BFFFF	Display buffer memory for VGA/ EGA / CGA / MONOCHROME adapter
00C0000-00DFFFF	Reserved for I/O device BIOS ROM or RAM buffer.
00E0000-00EFFFF	Reserved for PCI device ROM
00F0000-00FFFFFF	System BIOS ROM
0100000-FFFFFFF	System extension memory

I/O Map :

I/O MAP	ASSIGNMENT
000-01F	DMA controller (Master)
020-021	Interrupt controller (Master)
022-023	Chipset controller registers I/O ports.
040-05F	Timer control registers.
060-06F	Keyboard interface controller (8042)
070-07F	RTC ports & CMOS I/O ports
080-09F	DMA register
0A0-0BF	Interrupt controller (Slave)
0C0-0DF	DMA controller (Slave)
0F0-0FF	Math coprocessor
1F0-1F8	Hard Disk controller
278-27F	Parallel port-2
2B0-2DF	Graphics adapter controller
2F8-2FF	Serial port-2
360-36F	Net work ports
378-37F	Parallel port-1
3B0-3BF	Monochrome & Printer adapter
3C0-3CF	EGA adapter
3D0-3DF	CGA adapter
3F0-3F7	Floppy disk controller
3F8-3FF	Serial port-1