USER MANUAL

RIO-47xxx

Manual Rev. 1.0k

By Galil Motion Control, Inc.

*Galil Motion Control, Inc.
270 Technology Way
Rocklin, California 95765
Phone: (916) 626-0101
Fax: (916) 626-0102
Email: support@galilmc.com
URL: www.galilmc.com*

Rev Date 01/2011

Contents

CONTENTS	I
CHAPTER 1 OVERVIEW	1
INTRODUCTION	1
PART NUMBERING OVERVIEW	2
RIO-47xx0 vs. RIO-47xx2	3
RIO Functional Elements	3
CHAPTER 2 GETTING STARTED.....	4
RIO-471XX.....	4
RIO-472XX.....	5
INSTALLING THE RIO BOARD	5
Step 1. Configure Jumpers	5
Step 2. Connecting Power to the RIO.....	6
Step 3. Install the Communications Software.....	7
Step 4. Establish Communications between RIO and the Host PC	7
Communicating to the RIO using Galil Software.....	7
Using Non-Galil Communication Software	7
CHAPTER 3 COMMUNICATION	10
INTRODUCTION	10
RS232 PORT	10
RS-232 Configuration	10
ETHERNET CONFIGURATION	10
Communication Protocols	10
Jumper Configuration for 10BaseT.....	11
Addressing.....	11
Email from the RIO.....	12
Communicating with Multiple Devices.....	12
Handling Communication Errors	13
Multicasting.....	13
Unsolicited Message Handling.....	13
Other Protocols Supported	14
MODBUS WITH THE RIO	14
Raw Modbus Send/Receive.....	15
Modbus Read/Write to Array Table	15
Sending Modbus Packets.....	15
Modbus Exceptions	15
Function Code 1 (\$01) - Read Coils.....	17
Function Code 2 (\$02) - Read Discrete Inputs	19

Function Code 3 (\$03) - Read Holding Registers	21
Function Code 4 (\$04) - Read Input Registers	24
Function Code 5 (\$05) - Write Single Coil	27
Function Code 6 (\$06) - Preset Single Register	29
Function Code 7 (\$07) – Read Exception Status	31
Function Code 15 (\$0F) – Write Multiple Coils	33
Function Code 16 (\$10) – Write Multiple Registers	35
Analog IO Ranges	38
DATA RECORD	39
QR and DR Commands	39
RIO Data Record	39
Explanation of Status Information	40
CHAPTER 4 I/O	41
INTRODUCTION	41
SPECIFICATIONS	41
Digital Outputs	41
Digital Inputs	43
Analog Outputs	44
Analog Inputs	45
Analog Process Control Loop	46
CHAPTER 5 PROGRAMMING.....	49
OVERVIEW	49
EDITING PROGRAMS	49
PROGRAM FORMAT	49
Using Labels in Programs	50
Special Labels	50
Commenting Programs	50
Program Lines Greater than 40 Characters.....	51
Lock Program Access using Password.....	51
EXECUTING PROGRAMS - MULTITASKING.....	52
DEBUGGING PROGRAMS	52
Trace Commands.....	53
Error Code Command	53
RAM Memory Interrogation Commands	53
Operands	53
Debugging Example:	53
PROGRAM FLOW COMMANDS	54
Interrupts	54
Examples:	55
Conditional Jumps	56
Using If, Else, and Endif Commands	58
Stack Manipulation.....	59
Auto-Start Routine	59
Automatic Subroutines for Monitoring Conditions	59
MATHEMATICAL AND FUNCTIONAL EXPRESSIONS.....	61
Mathematical Operators	61
Bit-Wise Operators.....	63
Functions	64
VARIABLES	64
Programmable Variables	64
OPERANDS	65
Examples of Internal Variables:	65
Special Operands (Keywords).....	66
ARRAYS	66

Defining Arrays.....	66
Assignment of Array Entries	66
Using a Variable to Address Array Elements.....	67
Uploading and Downloading Arrays to On Board Memory.....	67
Automatic Data Capture into Arrays	67
Deallocating Array Space.....	68
INPUT OF DATA (NUMERIC AND STRING).....	69
Input of Data.....	69
OUTPUT OF DATA (NUMERIC AND STRING)	69
Sending Messages	69
Displaying Variables and Arrays.....	71
Formatting Variables and Array Elements	71
PROGRAMMABLE I/O	72
Digital Outputs	72
Digital Inputs.....	73
Analog Inputs	73
Analog Outputs	74
REAL TIME CLOCK.....	74
APPENDIX.....	75
ELECTRICAL SPECIFICATIONS	75
Input/Output	75
Power Requirements.....	75
PERFORMANCE SPECIFICATIONS	76
RIO-47xx0.....	76
RIO-47xx2.....	76
CERTIFICATIONS	76
ETL	76
CE.....	76
ROHS	76
STANDARD OPTIONS	77
-DIN	77
-NO DIN.....	77
-422	77
-RTC.....	77
-08-15 SOURCE (2LSRC) option.....	78
-0-7 or -8-15 SINK/SOURCE	78
-QUAD and -SSI	78
-PWM.....	79
-HS	80
-16Bit.....	80
AI_10v12Bit.....	81
AI_10v16Bit.....	81
-(4-20mA).....	81
AO Option (SCB-48608).....	81
CONNECTORS FOR RIO-47XXX	83
44 pin D-Sub Connector – RIO-471xx.....	83
26 pin D-Sub Connector – RIO-471xx.....	83
Screw Terminals – RIO-472xx.....	84
J2 RS-232 Port: DB-9 Pin Male	84
J1 Ethernet Port: 10/100 Base-T (RJ-45)	85
J5 Power: 2 pin Molex.....	85
JUMPER DESCRIPTION FOR RIO	86
RIO DIMENSIONS.....	87
RIO-471xx.....	87
RIO-472xx.....	88

ACCESSORIES AND OPTIONS	89
LIST OF OTHER PUBLICATIONS	90
CONTACTING US.....	90
TRAINING SEMINARS	91
WARRANTY.....	92
A1 – SCB-48206	93
DESCRIPTION	93
SPECIFICATIONS.....	94
WIRING.....	94
OPERATION.....	94
Method 1	95
Method 2	96
A2 – SCB-48306/48316	97
DESCRIPTION	97
SPECIFICATIONS.....	98
WIRING.....	98
OPERATION.....	99
INDEX	ERROR! BOOKMARK NOT DEFINED.

Chapter 1 Overview

Introduction

Derived from the same fundamentals used in building the Galil motion controllers, the RIO-47xxx is a programmable remote I/O controller that conveniently interfaces with other Galil boards through its Ethernet port. The RIO is programmed exactly the same way as a DMC (Digital Motion Controller) with the exception of a few revised commands and the removal of all motion-related commands. Communication with the RIO even works the same way as with other Galil controllers, and it utilizes the same software programs. Interrogation commands have been included to allow a user to instantly view the entire I/O status, I/O hardware, or Ethernet handle availability (see the TZ, ID and TH commands).

The purpose of an RIO board is to offer remote I/O in a system and the ability to synchronize complex events. To do this, the RIO consists of two boards – a high speed processor with integrated Ethernet and an I/O board consisting of digital inputs, digital outputs, analog inputs, and analog outputs. If different I/O requirements are required – a custom I/O board can be made to mate up directly with the RIO processor.

Part Numbering Overview

	Highlights	Options
RIO-47100	Metal case 0-5V Analog IO 8 high power optoisolated digital outputs 8 low power optoisolated digital outputs 16 optoisolated digital inputs	-DIN -08-15 SOURCE -HS -422 -4-20mA -PWM
RIO-47102	Same as RIO-47100 but with expanded memory	-DIN -08-15 SOURCE -HS -422 -4-20mA -RTC -PWM
RIO-47120	Same as RIO-47100 but with +-10V analog IO	-DIN -08-15 SOURCE -16 Bit -422 -HS -4-20mA -PWM
RIO-47122	Same as RIO-47120 but with expanded memory	-DIN -08-15 SOURCE -16 Bit -422 -HS -4-20mA -RTC -PWM -QUAD -SSI
RIO-47200	Same as RIO-47100 except -Screw terminals instead of D-Subs -Din rail mount with metal cover -All 16 outputs are high power -No analog outputs (use AO option to add analog)	-422 -0-7 SINK or -0-7 SOURCE -8-15 SINK or -8-15SOURCE -HS -10V12-Bit -10V16-Bit -NO DIN -4-20mA -PWM (8AO_5v_12bit), (8AO_10v12bit),(8AO_10v16bit)

For details on all the options please see [Standard Options](#) in the Appendix.

RIO-47xx0 vs. RIO-47xx2

Controller	# of array elements	# of program lines	# of variables	# of labels	# of control loops	# of Ethernet handles
RIO-47xx0	400	200	126	62	2	3
RIO-47xx2	1000	400	256	126	6	5

RIO Functional Elements

Microcomputer Section

The main processing unit of the RIO is a specialized 32-bit Freescale Microcomputer with 32KB SRAM and 256KB of Embedded Flash memory. The SRAM provides memory for variables, array elements and application programs. The flash memory provides non-volatile storage of variables, programs, and arrays; it also contains the RIO firmware. The RIO can process individual Galil Commands in approximately 40 microseconds.

The RIO product line has a maximum of 10,000 write cycles for burning (BN, BP, BV combined).

Communication

The communication interface with the RIO consists of one RS-232 port (default is 115 kBaud/s) and one 10/100Base-T Ethernet port (jumper configurable).

There are four status LEDs on the RIO that indicate operating and error conditions on the controller. Figure 1-1 shows a diagram of the LED bank followed by the description of the four lights.

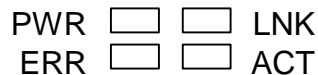

Figure 1-1 - Diagram of LED bank on the RIO

Green Power LED (PWR) - The green status LED indicates that the power has been applied properly to the RIO.

Red Status/Error LED (ERR) - The red error LED will flash on briefly at power up. After the initial power up condition, the LED will illuminate for the following reasons:

1. The reset line on the controller is held low or is being affected by noise.
2. There is a failure on the controller and the processor is resetting itself.
3. There is a failure with the output IC that drives the error signal.

Green Link LED (LNK) – The green LED indicates there is a valid Ethernet connection. This LED will show that the physical Ethernet layer (the cable) is connected.

Activity (ACT) – The amber LED indicates traffic across the Ethernet connection. This LED will show both transmit and receive activity across the connection.

Chapter 2 Getting Started

RIO-471xx

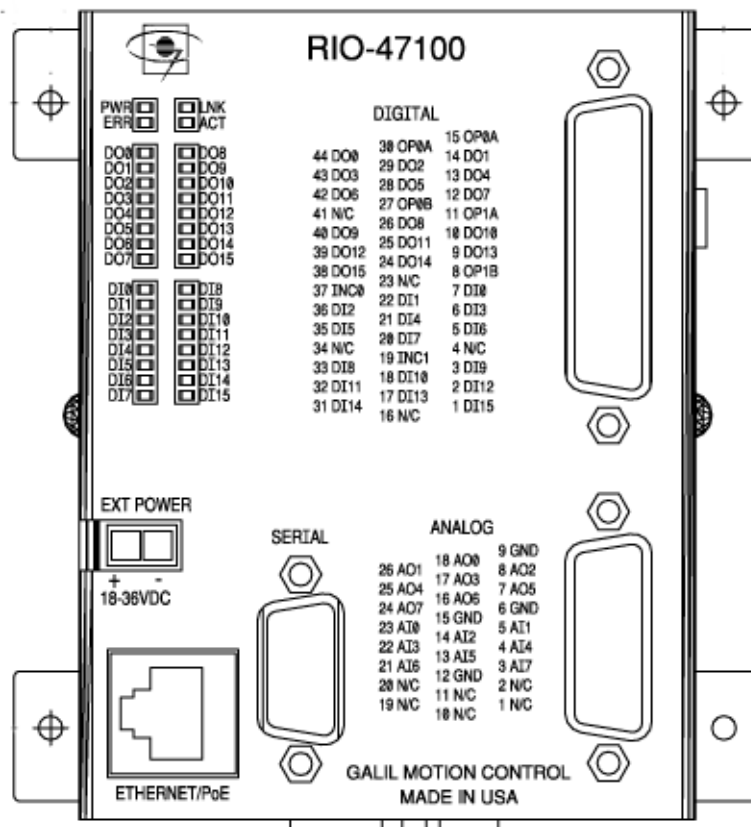

Figure 1: Outline of RIO-471xx (Dimensions listed in the Appendix)

RIO-472xx

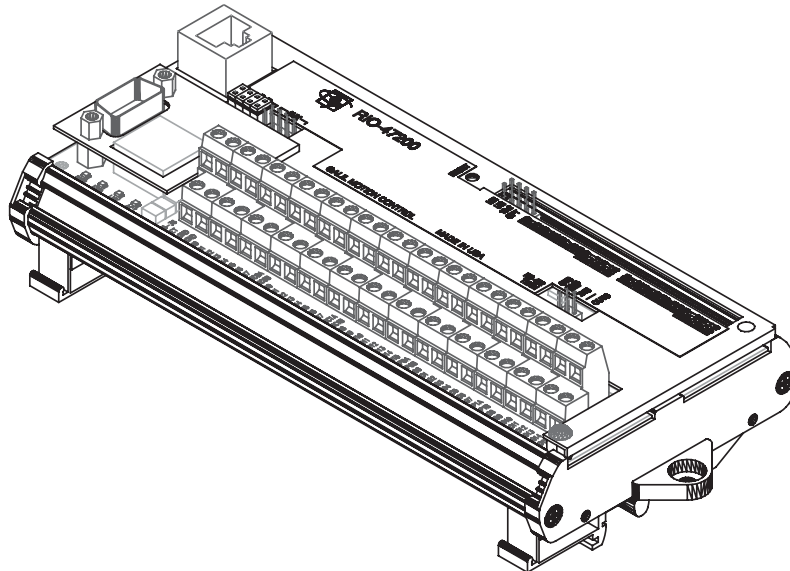

Figure 2: Outline of RIO-472xx (Dimensions listed in the Appendix)

Installing the RIO Board

Installation of a complete, operational RIO system consists of 4 steps:

- Step 1. Configure jumpers
- Step 2. Connect power to the RIO
- Step 3. Install the communications software
- Step 4. Establish communications between the RIO and the host PC

Step 1. Configure Jumpers

Power Input Jumpers (AUX vs PoE)

The RIO can be powered using either a 18-36V DC power input or a PoE (Power over Ethernet) switch to deliver power over the Ethernet cable. The default configuration is the 18-36VDC power input. If PoE is used, the **four** jumpers on JP6 for the RIO-471xx and JP1 for the RIO-472xx must be moved from AUX to PoE.

Master Reset and Upgrade Jumper

Jumpers labeled as MRST and UPGD are located at JP5 for the RIO-471xx and JP2 for the RIO-472xx, next to the reset button. The MRST jumper is for a master reset. When MRST is jumpered, the RIO will perform a master reset upon a power cycle to the board or when the board reset button is pushed. Whenever the I/O board has a master reset, all programs, arrays, and variables stored in non-volatile memory will be erased – **this will set the RIO board back to factory defaults.**

The UPGD jumper enables the user to unconditionally update the board firmware. This jumper is not necessary for firmware updates when the RIO board is operating normally, but may be necessary in cases of a corrupted non-volatile memory. non-volatile memory corruption should never occur under normal operating circumstances; however, corruption is possible if there is a power fault during a firmware update. If non-volatile memory corruption occurs, your board may not operate properly. In this case, install the UPGD jumper and use the update firmware function in the Galil software to re-load the system firmware.

Setting the Baud Rate on the RIO

The default baud rate for the RIO is 115K (jumper OFF).

The jumper labeled “19.2,” also located at JP5 for the RIO-471xx and JP2 for the RIO-472xx, allows the user to select the serial communication baud rate. The baud rate can be set using the following table:

19.2	BAUD RATE
OFF	115k
ON	19.2k

Step 2. Connecting Power to the RIO

Since the RIO can be powered using either a 18-36V DC power input or a PoE (Power over Ethernet) switch, there are two possible connection options shown here:

1) EXT: 18-36VDC power input is the default configuration. The four jumpers on JP6 for the RIO-471xx and JP1 for the RIO-472xx . Apply a DC power supply in the range of 18-36V to the 2-pin molex connector. The RIO-472xx has screw terminal power connectors marked 18-36 and RET in lieu of the molex connector. The power supply should be capable of delivering up to 4 Watts. The RIO uses Molex Pitch Mini-Fit, Jr.™ Receptacle Housing connectors for connecting DC Power. For more information on the connectors, go to <http://www.molex.com/>.

Note: The part number listed below is the connector that is found on the controller. For more information see the Molex website. <http://www.molex.com/>

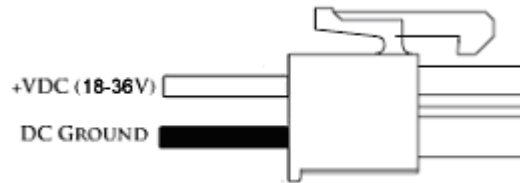

Molex Part Number	Pin Part Number (x2)	Type
39-31-0020	44476-3112	2 Position

Warning: Damage can occur if a supply larger than 36VDC is connected to the board.

2) PoE: Power over Ethernet. This configuration needs the four jumpers on JP6 for the RIO-471xx and JP1 for the RIO-472xx to be placed on the side labeled PoE. Once this is done, the controller will derive its power directly from the Ethernet cable. A PoE style switch can be used such as the FS108P from Netgear.

Applying power will turn on the green LED power indicator.

Step 3. Install the Communications Software

After applying power to the computer, install the Galil software that enables communication between the I/O board and your PC. It is strongly recommended to use the Galil software “GalilTools” when communicating to the RIO unit. Please see the GalilTools Manual for a complete description of how to install and connect to Serial or Ethernet controllers.

<http://www.galilmc.com/products/software/galiltools.html>

Step 4. Establish Communications between RIO and the Host PC

Communicating to the RIO using Galil Software

RS-232:

To use serial communication, connect a 9pin **straight-through RS-232 cable** (CABLE-9-PIND) between the serial port of the RIO and the computer or terminal communications port. The RIO serial port is configured as DATASET.

Ethernet:

Connect the RIO Ethernet port to your computer via a crossover Ethernet cable, or to a network hub with a straight through Ethernet cable.

Using Non-Galil Communication Software

RS-232:

The RIO serial port is configured as DATASET. The computer or terminal must be configured as a for full duplex, no parity, 8 data bits, one start bit and one stop bit. A standard Windows HyperTerminal session can connect to the controller using a straight-through serial cable.

Check to insure that the baud rate jumpers have been set to the desired baud rate as described above. Also, the hardware handshake lines (RTS/CTS) need to be connected. See Chapter 3 for more information on ‘Handshake Modes.’

Ethernet:

Connect the RIO Ethernet port to your computer via an Ethernet crossover cable, or to a network hub by a straight through Ethernet cable. An IP address needs to be assigned via a DHCP server, through Galil software, or via a serial cable using the IA command. See Chapter 3 for more information on how to establish an IP address. Once an IP address is established, a standard Windows Telnet session can connect to the controller.

* Note that the RIO-471x2 supports auto-crossover detection (auto MDIX)

Sending Test Commands to the Terminal after a successful Connection

After connecting to the computer or terminal, press <carriage return> or the <enter> key on the keyboard. In response to carriage return {CR}, the controller responds with a colon, :

Now type

TZ {CR}

This command directs the RIO to return the current I/O status. The controller should respond with something similar to the following:

```
:TZ
Block 0 (7-0) Inputs - value 255 (1111_1111)
Block 1 (15-8) Inputs - value 255 (1111_1111)
Block 0 (7-0) Outputs - value 0 (0000_0000)
Block 1 (15-8) Outputs - value 0 (0000_0000)
Analog Inputs(7-0)
0.0000,0.0000,0.0000,0.0000,0.0037,0.0012,0.0000,0.0000
Analog Outputs(7-0)
0.0000,0.0000,0.0000,0.0000,0.0000,0.0000,0.0000,0.0000
```

RIO Web Server

The RIO has a built-in web server that can be accessed by typing the IP address of the controller into a standard web browser. The controller comes from the factory without any IP address assigned so a user must go through the steps outlined above to establish an IP address before the web-server is accessible. Figure 3 shows an output of the RIO Web Server:

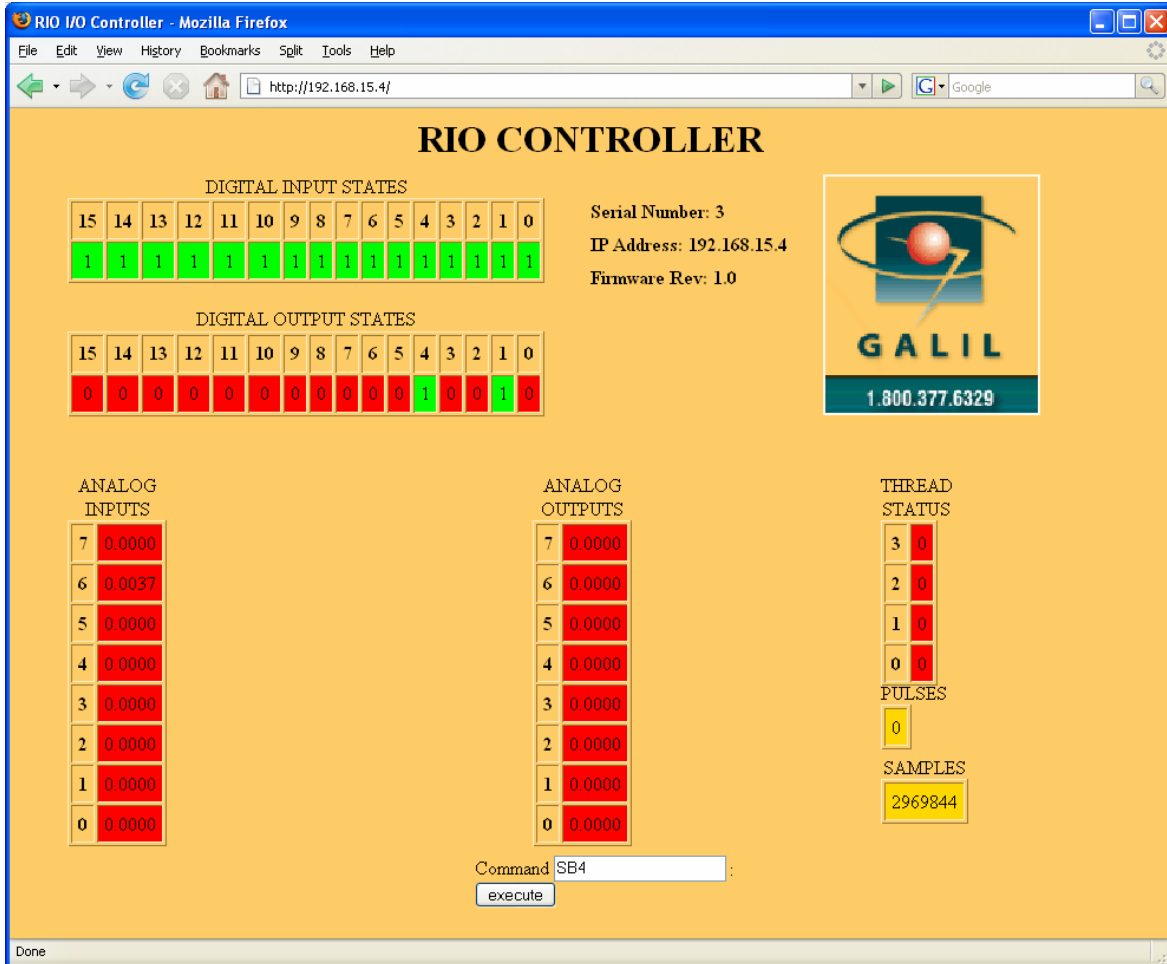

Figure 3: RIO Web Server Output

Chapter 3 Communication

Introduction

The RIO has one RS-232 port and one Ethernet port. The RS-232 port is the data set, and it is a standard serial link with a communication baud rate up to 115kbaud. The Ethernet port is jumper configurable for 10 or 100Base-T (default).

RS232 Port

The RIO board has a single RS232 connection for sending and receiving commands from a PC or other terminal. The pin-outs for the RS232 connection can be found in the Appendix - [J5 Power: 2 pin Molex](#).

RS-232 Configuration

Configure the PC for 8 data bits, no parity, one stop bit, and hardware handshaking. The baud rate for the RS232 communication defaults to 115k baud but can be set to 19.2k baud by placing a jumper on J5. The serial port has a 4 bytes FIFO.

Handshaking Modes

The RS232 port is configured for hardware handshaking. In this mode, the RTS and CTS lines are used. The CTS line will go high whenever the RIO is not ready to receive additional characters. The RTS line will inhibit the RIO board from sending additional characters. **Note:** The RTS line goes high for inhibit. This handshake procedure is required and ensures proper communication especially at higher baud rates.

Ethernet Configuration

Communication Protocols

The Ethernet is a local area network through which information is transferred in units known as packets. Communication protocols are necessary to dictate how these packets are sent and received. The RIO supports two industry standard protocols, TCP/IP and UDP/IP. The board will automatically respond in the format in which it is contacted.

TCP/IP is a "connection" protocol. The master must be connected to the slave in order to begin communicating. Each packet sent is acknowledged when received. If no acknowledgement is received, the information is assumed lost and is resent.

Unlike TCP/IP, UDP/IP does not require a "connection". This protocol is similar to communicating via RS232. If a cable is unplugged, the device sending the packet does not know that the information was not received on the other side. Because the protocol does not provide for lost information, the sender must re-send the packet.

Galil recommends using TCP/IP for standard communication to insure that if a packet is lost or destroyed while in transit, it will be resent. However UDP is recommended in certain situations such as launching Data Record information to a host for graphing or data collection.

Each packet must be limited to 470 data bytes or less. This is not an issue when using Galil software as the Galil Ethernet driver will take care of the low level communication requirements.

The IK command blocks the controller from receiving packets on Ethernet ports lower than 1000 except for ports 0, 23, 25, 68, 80 and 502. To receive packets on all ports, set IK to 0.

NOTE: In order not to lose information in transit, Galil recommends that the user wait for an acknowledgement of receipt of a packet before sending the next packet.

Jumper Configuration for 10BaseT

If 10BaseT communication is required, a jumper must be placed on the pins labeled OPT. The default is no jumper which is 100BaseT Ethernet communication.

Addressing

There are three levels of addresses that define Ethernet devices. The first is the MAC or hardware address. This is a unique and permanent 6 byte number. No other device will have the same MAC address. The RIO MAC address is set by the factory and the last two bytes of the address are the serial number of the board. To find the Ethernet MAC address for a RIO unit, use the TH command. A sample is shown here with a unit that has a serial number of 3:

Sample MAC Ethernet Address: 00-50-4C-28-00-03

The second level of addressing is the IP address. This is a 32-bit (or 4 byte) number that usually looks like this: 192.168.15.1. The IP address is constrained by each local network and must be assigned locally. Assigning an IP address to the RIO board can be done in a number of ways.

The first method for setting the IP address is using a DHCP server. The DH command controls whether the RIO board will get an IP address from the DHCP server. If the unit is set to DH1 (default) and there is a DHCP server on the network, the controller will be dynamically assigned an IP address from the server. Setting the board to DH0 will prevent the controller from being assigned an IP address from the server.

The second method to assign an IP address is to use the BOOT-P utility via the Ethernet connection. The BOOT-P functionality is only enabled when DH is set to 0. Either a BOOT-P server on the internal network or the Galil software may be used. When opening the Galil Software, it will respond with a list of all RIO boards and controllers on the network that do not currently have IP addresses. The user must select the board and the software will assign the specified IP address to it. This address will be burned into the controller (BN) internally to save the IP address to the non-volatile memory. Note: if multiple boards are on the network – use the serial numbers to differentiate them.

CAUTION: Be sure that there is only one BOOT-P or DHCP server running. If your network has DHCP or BOOT-P running, it may automatically assign an IP address to the RIO board upon linking it to the network. In order to ensure that the IP address is correct, please contact your system administrator before connecting the I/O board to the Ethernet network.

The third method for setting an IP address is to send the IA command through the RS-232 port. (Note: The IA command is only valid if DH0 is set). The IP address may be entered as a 4 byte number delimited by commas (industry standard uses periods) or a signed 32 bit number (e.g. IA 124,51,29,31 or IA 2083724575). Type in BN to save the IP address to the RIO non-volatile memory.

NOTE: Galil strongly recommends that the IP address selected is not one that can be accessed across the Gateway. The Gateway is an application that controls communication between an internal network and the outside world.

The third level of Ethernet addressing is the UDP or TCP port number. The Galil board does not require a specific port number. The port number is established by the client or master each time it connects to the RIO board. Typical port numbers for applications are:

Port 23: Telnet
Port 502: Modbus
Port 80: HTTP

Email from the RIO

If the RIO is on a network with a SMTP Mail Server, the RIO is capable of sending an email message using the MG command. There are three configuration commands necessary to send an email from the RIO unit – MA, MS and MD. MA sets the smtp email server IP address. MS sets the email source or “from” address and MD sets the destination or “to” address. There is a maximum character limit for the MS and MD commands of 30 characters. An example of this is shown here:

MA 10,0,0,1;	‘example SMTP Email Server IP address
MD someone@example.com ;	‘sample destination email address
MS me@example.com ;	‘sample source address
MG "Testing Email" {M};	‘Message to send via Email

Please contact your system administrator for information regarding email settings.

Note: it is strongly recommended that the email messaging frequency is limited so as not to overload the email server.

Communicating with Multiple Devices

The RIO is capable of supporting multiple masters or slaves. A typical scenario would be connecting a PC (a master) and a motion controller (a 2nd master) that can both send commands to the RIO board over Ethernet on different handles.

Note: The term “master” is equivalent to the Internet “client” and the term “slave” is equivalent to the Internet “server”.

An Ethernet handle is a communication resource within a device. The RIO-47xx0 can have a maximum of 3 Ethernet handles open at any time. This number is increased to 5 Ethernet handles on the RIO-47xx2. If all handles are in use and another device tries to connect, it will be sent a "reset packet" showing that the RIO cannot establish any new connections.

NOTE: A reset will cause the Ethernet connection to be lost. There are a number of ways to reset the board. Hardware resets (push reset button or power down RIO board) and software resets (through Ethernet or RS232 by entering the RS command).

When the RIO acts as the master, the IH command is used to assign handles and connect to its slaves. The IP address may be entered as a 4 byte number separated with commas (industry standard uses periods) or as a signed 32 bit number. A port number may also be specified, but if it is not, it will default to 1000. The protocol (TCP/IP or UDP/IP) to use must also be designated at this time. Otherwise, the board will not

connect to the slave. (Ex: IHB=151,25,255,9<179>2. This will open handle #2 and connect to the IP address 151.25.255.9, port 179, using TCP/IP)

Once the IH command is used to connect to slaves, the user can communicate to these slaves by sending commands to the master. The SA command is used for this purpose, and it has the following syntax.

SAh= "command string"

Here "command string" will be sent to handle h. For example, SAA="XQ" command will send an XQ command to the slave/server on handle A. A more flexible form of the command is

SAh= field1,field2,field3,field4 ... field8

where each field can be a string in quotes or a variable.

When the Master/client sends an SA command to a Slave/server, it is possible for the master to determine the status of the command. The response _IHh4 will return the number 1 to 4. 1 indicates waiting for the acknowledgement from the slave. 2 indicates a colon (command accepted) has been received. 3 indicates a question mark (command rejected) has been received. 4 indicates the command timed out.

If a command generates multiple responses (such as the TE command), the values will be stored in _SAh0 thru _SAhn where n is the last field. If a field is unused, its _SA value will be -2^31.

See the Command Reference for more information on the SA command.

Which devices receive what information from the RIO depends on various things. If a device queries the RIO, it will receive the response unless it explicitly tells the RIO to send it to another device. If the command that generates a response is part of a downloaded program, the response will route to whichever port is specified by the CF command (either a specific Ethernet handle or the RS232 port). If the user wants to send the message to a port other than what is specified by the CF command, add an {Eh} or {P1} to the end of the command (Ex. MG{EB}"Hello" will send the message "Hello" to handle #2 and MG{P1}"Hello" will send it to the serial port).

Handling Communication Errors

A reserved automatic subroutine which is identified by the label #TCPERR can be used to catch communication errors. If an RIO has an application program running and the TCP communication is lost, the #TCPERR routine will automatically execute. The #TCPERR routine should be ended with the RE command.

Multicasting

A multicast may only be used in UDP/IP and is similar to a broadcast (where everyone on the network gets the information) but specific to a group. In other words, all devices within a specified group will receive the information that is sent in a multicast. There can be many multicast groups on a network and are differentiated by their multicast IP address. To communicate with all the devices in a specific multicast group, the information can be sent to the multicast IP address rather than to each individual device IP address. All Galil devices belong to a default multicast address of 239.255.19.56. This multicast IP address can be changed by using the IA>u command.

Unsolicited Message Handling

Unsolicited messages are any messages that are sent from the controller that are not directly requested by the host PC. An example of this is a MG or TP command inside of a program running on the controller. Error messages are also "unsolicited" because they can come out at any time. There are two software commands that will configure how the controller handles these unsolicited messages: CW and CF.

The RIO has 3 Ethernet handles as well as 1 serial port where unsolicited messages may be sent. The CF command is used to configure the controller to send these messages to specific ports. In addition, the Galil

software has various options for sending messages using the CF command. For more information, see the CF command description in the Command Reference.

The CW command has two data fields that affect unsolicited messages. The first field configures the most significant bit (MSB) of the message. A value of 1 will set the MSB of unsolicited messages, while a value of 2 suppresses the MSB. Programs like HyperTerminal or Telnet need to use a setting of CW2 for the unsolicited messages to be readable in standard ASCII format. However, the Galil software needs a value of CW1 to be set so that it can differentiate between solicited and unsolicited messages. If you have difficulty receiving characters from the controller, or receive garbage characters instead of messages, check the status of the CW command.

The second field of the CW command controls whether the product should pause while waiting for the hardware handshake to enable the transmission of characters over RS-232 (CW,0), or continue processing commands and lose characters until the hardware handshake allows characters to be sent (CW,1).\

Other Protocols Supported

Galil supports DHCP, ARP, BOOT-P, and Ping, which are utilities for establishing Ethernet connections. ARP is an application that determines the Ethernet (hardware) address of a device at a specific IP address. BOOT-P is an application that determines which devices on the network do not have an IP address and assigns the IP address you have chosen to it. Ping is used to check the communication between the device at a specific IP address and the host computer.

The RIO can communicate with a host computer through any application that can send TCP/IP or UDP/IP packets. A good example of this is Telnet, a utility that comes standard with the Windows operating system.

When using DHCP and a DNS (Domain Name Server), the DNS will assign the name “RIO47100-n” to the controller where n is the serial number of the unit.

Modbus with the RIO

The RIO-47xxx supports Modbus/TCP, and requires an Ethernet connection between its master or slave devices.

As a Modbus class 1 device, the RIO supports the following Modbus function codes:

Function Code	Modbus Description	Galil Description
1	Read Coil Status	Read Digital Outputs
2	Read Input Status	Read Digital Inputs
3	Read Holding Registers	Read Analog Inputs
4	Read Input Registers	Read Analog Outputs
5	Force Single Coil	Write Digital Output
6	Preset Single Register	Write Digital Outputs
7	Read Exception Status	Read Digital Outputs
15	Force Multiple Coils	Write Digital Outputs
16	Preset Multiple Registers	Write Analog Outputs

Of the Modbus function codes the RIO supports, all are supported by the RIO when it operates as a master (also known as a client) or when it operates as a slave (server).

Note 1: By default the RIO uses function code 3 for analog inputs and function code 4 for analog outputs. For a majority of Modbus devices this functionality is inverted. Use the MV command to switch the functionality. Please see the command reference for details.

Note 2: The remainder of this document uses the '\$' symbol to signify that numbers are in hexadecimal notation.

Setup

Modbus/TCP requires an Ethernet connection between master and slave. Modbus/TCP also requires that all slaves communicate with their masters over port 502. See the IH command to setup port communication for the RIO.

Raw Modbus Send/Receive

Firmware revisions Rev D and newer support raw Modbus read/write functionality. This provides the user with the most flexibility for interfacing to modbus devices. Specifying a -1 for the Modbus function code enables the raw read/write of Modbus functions.

See the MB command in the RIO Command Reference for further details.

Modbus Read/Write to Array Table

Firmware revisions Rev D and newer support the ability to read from and write to array data on the RIO. Up to 1000 elements are available in the RIO-471x2 and 400 in the RIO-47xx0. Each element is accessible as a 16 bit unsigned integer (Modbus register 1xxx) -OR- as a 32 bit floating point number (Modbus registers 2xxx).

See the ME command in the RIO Command Reference for further details.

Sending Modbus Packets

The RIO programming language provides 3 ways of issuing Modbus packets as a master.

- 1) Issue the MB command of type Mbh = -1,len,array[]

This Galil command allows the user complete control over the creation of their Modbus packet. len is the number of bytes to be included in the packet, and array[] is the name of the array containing the Modbus packet. Each element of array[] may contain only one byte, and array[] must contain the entire Modbus packet, including transaction identifiers, protocol identifiers, length field, Modbus function code, and data specific to that function code.

- 2) Issue the MB command of type Mbh = addr, x, m, n, array[]

This Galil command allows the user to send a Modbus command easily by allowing the user to select a few key parameters, and allowing the controller to do the rest. addr is the Unit ID field, which if not set, Galil will automatically set to the value of the handle the communication is over (Handle A=\$01, B=\$02, etc). Also, as a slave the RIO ignores the Unit ID field. x is the function code of the Modbus command. m is the address at which to begin reading or writing. n is either the number of coils or the number of registers to read/write. array[] is the array in which data from a read gets stored or where data to write is stored. See individual function code descriptions in the command reference for specifics of this command.

- 3) Issue another Galil command that supports Modbus

The following Galil commands support Modbus, and are an easy way to use the Modbus protocol: SB,CB,AO,OB,@IN[],@OUT[],@AN[],@AO[]. The I/O number (variable) to use with these commands when using Modbus can be calculated as follows:

$$\text{I/O Number} = (\text{HandleNum} * 1000) + (\text{bitNum})$$

Modbus Exceptions

An RIO configured as a slave will return an exception response if it receives an invalid request (e.g. An invalid function code, or a communication error). As a class 1 Modbus device the RIO-47xxx can respond with exception codes \$01 or \$02. Exception code \$01 is returned when a request referencing an Illegal

Function is received. Exception code \$02 is returned when a request referencing an Illegal Data Address is received.

When an Exception Response occurs, the function code of the response is \$80 added to the original function code (e.g. Improper use of function code \$01 will result in the exception response \$81)

An RIO-47xxx configured as a master can query the function code of the last response it received using the `_MW` command (see command reference). The `_MW` command can be used to determine if an exception has occurred. The `_MW1` command (see the command reference) can be used to query the exception code.

Function Code 1 (\$01) - Read Coils

Description

Modbus function code \$01 is a request to read coils. This will read digital outputs from an RIO configured as a slave.

Operating as a master

The function code of the response can be queried with the `_MW` command. If an exception occurred, the exception code of the response can be queried with `_MW1`.

Example:

Normal Response
`_MW` results in \$01

Exception Response
`_MW` results in \$81
`_MW1` contains \$01 or \$02

When using the MB command with Modbus function code 1, response data will be stored in the array referenced in the command line. When using `@OUT[]`, `@OUT[]` contains the response data, which can either be stored to a variable or transmitted via serial port or ethernet.

Ways to use function code \$01 with Galil commands:

1. MB command in raw packet mode
2. MB command with Modbus function code 1
3. `@OUT[]` (see `@OUT[]` in the command reference)

Operating as a slave

The RIO will accept a read coils request with a starting address ranging from \$0000-\$000F, referencing digital outputs 0-15. The RIO will accept a request for up to all 16 of its digital outputs, with the quantity of coils ranging from \$0001-\$0010. The RIO will respond with function code \$01 followed by a byte count of either \$01 or \$02, which describes the number of bytes of digital outputs being returned (byte count = quantity of outputs/8; if the remainder is not 0, byte count = quantity of outputs/8 + 1). The RIO will respond with a coil status of 1 or 2 bytes (equal to the byte count) ranging from \$0001-\$FFFF, with each bit representing the state of a digital output (1 or 0). The LSB of the first coil status byte refers to the output addressed by the request packet.

Coil Mapping

Coil	Addresses	Coil	Addresses
0	Digital Output 0	8	Digital Output 8
1	Digital Output 1	9	Digital Output 9
2	Digital Output 2	10	Digital Output 10
3	Digital Output 3	11	Digital Output 11
4	Digital Output 4	12	Digital Output 12
5	Digital Output 5	13	Digital Output 13
6	Digital Output 6	14	Digital Output 14
7	Digital Output 7	15	Digital Output 15

Examples:

MBA= ,1,2,12,array[]

Request the status of coils 2-13 (result is stored in array[])

MG@OUT[1002]

Requests the status of coil 2 (result is transmitted via serial port or ethernet)

Packets

The command MBA=,1,2,10,array[] results in the following packets being sent, when one RIO is the master, and another RIO is the slave, communicating over handle A, port 502(Modbus). Assume digital outputs, in descending order from 15-0 are: 0,1,1,1,0,0,1,1,0,0,1,1,0,1,1,1

Request		Response	
Field Name	(hex)	Field Name	(hex)
Function	01	Function	01
Starting Address High	00	Byte Count	02
Starting Address Low	02	Outputs Status 9-2	CD
Quantity of Outputs High	00	Outputs Status 13-10	0C
Quantity of Outputs Low	0C		

1st Byte of Response Word

bit	7	6	5	4	3	2	1	0
Coil #	9	8	7	6	5	4	3	2
Value	1	1	0	0	1	1	0	1

2nd Byte of Response Word

bit	15	14	13	12	11	10	9	8
Coil #	X	X	X	X	13	12	11	10
Value	0	0	0	0	1	1	0	0

Note: bits in the response marked 'X' are not valid coil response data, but are instead 0's that fill the remainder of the byte

On the master RIO, array[0]=205 and array[1]=12 after the MBA= ,2,2,12,array[]command is issued

Function Code 2 (\$02) - Read Discrete Inputs

Description

Modbus function code \$02 is a request to read discrete inputs. This will read digital inputs from an RIO configured as a slave.

Operating as a master

The function code of the response can be queried with the `_MW` command. If an exception occurred, the exception code of the response can be queried with `_MW1`.

Example:

<u>Normal Response</u>	<u>Exception Response</u>
<code>_MW</code> results in \$02	<code>_MW</code> results in \$82
	<code>_MW1</code> contains \$01 or \$02

When using the MB command with Modbus function code \$02, response data will be stored in the array referenced in the command line. When using `@IN[]`, `@IN[]` contains the response data, which can either be stored to a variable or transmitted via serial port or ethernet.

Ways to use function code 2 with Galil commands:

1. MB command in raw packet mode
2. MB command with Modbus function code 2
3. `@IN[]` (see `@IN[]` in the command reference)

Operating as a slave

The RIO will accept a read discrete inputs request with a starting address ranging from \$0000-\$000F, referencing digital inputs 0-15. The RIO will accept a request for up to all 16 of its digital inputs, with a quantity of inputs range of \$0001-\$0010.

The RIO will respond with a byte count of either \$01 or \$02, which describes the number of bytes of digital inputs being returned (byte count = quantity of inputs/8; if the remainder is not 0, byte count = quantity of inputs/8 +1). The RIO will respond with an input status of 1 or 2 bytes (equal to the byte count) ranging from \$0001-\$FFFF, with each bit representing the state of a digital input (1 or 0). The LSB of the first input status byte refers to the input addressed by the request packet.

Coil Mapping

Coil	Addresses	Coil	Addresses
0	Digital Input 0	8	Digital Input 8
1	Digital Input 1	9	Digital Input 9
2	Digital Input 2	10	Digital Input 10
3	Digital Input 3	11	Digital Input 11
4	Digital Input 4	12	Digital Input 12
5	Digital Input 5	13	Digital Input 13
6	Digital Input 6	14	Digital Input 14
7	Digital Input 7	15	Digital Input 15

Examples:

MBA= ,2,2,12,array[] Request the status of discrete inputs 2-13 (result is stored in array[])

MG@IN[1002] Requests the status of input 2 (result is transmitted via serial port or ethernet)

Packets:

The command MBA=,2,2,12,array[] results in the following packets being sent, when one RIO is the master, and another RIO is the slave, communicating over handle A, port 502(Modbus). Assume digital inputs, in descending order from 15-0 are: 0,1,1,1,0,0,1,1,0,0,1,1,0,1,1,1.

Request		Response	
Field Name	(hex)	Field Name	(hex)
Function	02	Function	02
Starting Address High	00	Byte Count	02
Starting Address Low	02	Inputs Status 9-2	CD
Quantity of Inputs High	00	Inputs Status 13-10	0C
Quantity of Inputs Low	0C		

1st Byte of Response Word

bit	7	6	5	4	3	2	1	0
Input #	9	8	7	6	5	4	3	2
Value	1	1	0	0	1	1	0	1

2nd Byte of Response Word

bit	15	14	13	12	11	10	9	8
Input #	X	X	X	X	13	12	11	10
Value	0	0	0	0	1	1	0	1

Note: bits in the response marked 'X' are not valid input response data, but are instead 0's that fill the remainder of the byte. Inputs report back a 0 when active and a 1 when inactive

On the master RIO, array[0]=205 and array[1]=12 after the MBA= ,2,2,12,array[] command is issued

Function Code 3 (\$03) - Read Holding Registers

Description

Modbus function code \$03 is a request to read holding registers. In its default configuration the RIO-471x0 responds to this command with analog input register information. To configure the RIO to respond to a function code 3 request with analog output information see the MV command in the command reference.

Operating as a master

The function code of the response can be queried with the `_MW` command. If an exception occurred, the exception code of the response can be queried with `_MW1`.

Example:

<u>Normal Response</u>	<u>Exception Response</u>
<code>_MW</code> results in \$03	<code>_MW</code> results in \$83
	<code>_MW1</code> contains \$01 or \$02

When using the MB command with Modbus function code \$03, response data will be stored in the array referenced in the command line. When using `@AN[]`, `@AN[]` contains the response data, which can either be stored to a variable or transmitted via serial port or ethernet.

Ways to use function code 3 with Galil commands:

1. MB command in raw packet mode
2. MB command with Modbus function code 3
3. `@AN[]` (see `@AN[]` in the command reference)

Operating as a slave

The RIO will accept different starting address ranges for a read holding registers request depending on the state of the MI command. If MI is set to 0 (register data is volts in 32-bit floating point), the RIO will accept a read holding registers request with an address range of \$0000-\$000E. If MI is set to 1 (register data is counts in 16-bit decimal), The RIO will accept a read holding registers request with an address range of \$0000-\$0007. The RIO will accept a request with a quantity of registers field up to \$0008 if MI is set to 0, and \$00010 if MI is set to 1.

The RIO will respond with a byte count ranging from \$0000 to \$0020 if MI is 0, and from \$0000 to \$0010 if MI is 1 (Byte Count = 2*NumberOfRegisters, where NumberOfRegisters is equal to the number of analog inputs you are trying to read multiplied by 2 if MI is 0, or 1 if MI is 1). The RIO will respond with a byte count field equal to the byte count field in the request packet. The RIO will respond with a register value field consisting of either 2 bytes (counts) or 4 bytes (32-bit floating point) per analog input in ascending order from the analog input referenced in the address.

Galil Register Map

Register Address	32-Bit Floating Point	Counts
0	Analog Input 0	Analog Input 0
1		Analog Input 1
2	Analog Input 1	Analog Input 2
3		Analog Input 3
4	Analog Input 2	Analog Input 4
5		Analog Input 5
6	Analog Input 3	Analog Input 6
7		Analog Input 7
8	Analog Input 4	
9		
10	Analog Input 5	
11		
12	Analog Input 6	
13		
14	Analog Input 7	
15		

Examples:

MBA= ,3,2,4,array[]	Request the status of holding registers 2-5 (AN1 and AN2 if MI0, or AN2, AN3, AN4, AN5 if MI1). The response is stored in array[]
MG@AN[1002]	Requests the status of analog input 2 (result is transmitted via serial port or ethernet).

Packets:

The command `MBA=,3,2,4,array[]` results in the following packets being sent, when one RIO is the master, and another RIO-47100 is the slave, communicating over handle A, port 502(Modbus). When MI is set to 0 the response is given as volts in 32-bit Floating Point. When MI is set to 1 the response is given as counts in 16-bit decimal notation. Assume analog inputs in ascending order from 0-7 are: .4822, .9753, 1.4673, 1.9629, 2.4622, 2.9675, 3.4583, 3.9600

		<i>Slave MIO</i>			<i>Slave MI1</i>		
Request		Response			Response		
Field Name	(hex)	32-bit Floating Point Field Name	(hex)	Real Value (volts)	16-bit Integer Field Name	(hex)	Real Value (counts)
Function	03	Function	03		Function	03	
Starting Address High	00	Byte Count	08		Byte Count	08	
Starting Address Low	02	RegVal2 High	3F	0.9753	RegVal2 High	25	9600
Quantity of Registers High	00		79		RegVal2 Low	80	
Quantity of Registers Low	04		B0		RegVal3 High	32	12904
		RegVal2 Low	00		RegVal3 Low	68	
		RegVal3 High	3F	1.4673	RegVal4 High	3F	16160
			BB		RegVal4 Low	20	
			D0		RegVal5 High	4C	19480
		RegVal3 Low	00		RegVal5 Low	18	

With the slave MI set to 0, the master RIO's arrays will look like this:

```
array[0]=16249
array[1]=45056
array[2]=16315
array[3]=53248
```

With the slave MI set to 1, the master RIO's arrays will look like this:

```
array[0]=9600
array[1]=12904
array[2]=16160
array[3]=19480
```

Function Code 4 (\$04) - Read Input Registers

Description

Modbus function code \$04 is a request to read input registers. In its default configuration the RIO-471x0 responds to this command with analog output register information. To configure the RIO to respond to a function code 4 request with analog input information see the MV command in the command reference.

Operating as a master

The function code of the response can be queried with the `_MW` command. If an exception occurred, the exception code of the response can be queried with `_MW1`.

Example:

<u>Normal Response</u>	<u>Exception Response</u>
<code>_MW</code> results in \$04	<code>_MW</code> results in \$84
	<code>_MW1</code> contains \$01 or \$02

When using the MB command with Modbus function code \$04, response data will be stored in the array referenced in the command line. When using `@AO[]`, `@AO[]` contains the response data, which can either be stored to a variable or transmitted via serial port or ethernet.

Ways to use function code1 with Galil commands:

1. MB command in raw packet mode
2. MB command with Modbus function code 4
3. `@AO[]` (see `@AO[]` in the command reference)

Operating as a slave

The RIO will accept different address ranges for a read input registers request depending on the state of the MI command. If MI is set to 0 (register data is volts in 32-bit floating point), the RIO will accept a read input registers request with an address range of \$0000-\$000E. If MI is set to 1 (register data is counts in 16-bit decimal), The RIO will accept a read input registers request with an address range of \$0000-\$0007. The RIO will accept a request with a quantity of registers field up to \$0008 if MI is set to 0, and \$00010 if MI is set to 1. The RIO will respond with a byte count ranging from \$0000 to \$0010 if MI is 1, and from \$0000 to \$0020 if MI is 0 ((byte count = 2*NumberOfRegisters, where NumberOfRegisters is equal to the number of analog outputs you are trying to read multiplied by 2 if MI is 0, or 1 if MI is 1). The RIO will respond with an input registers field consisting of either 2 bytes (counts) or 4 bytes (32-bit floating point) per analog output register in ascending order from the analog output referenced in the address.

Galil Register Map

Register Address	32-Bit Floating Point	Counts
0	Analog Output 0	Analog Output 0
1		Analog Output 1
2	Analog Output 1	Analog Output 2
3		Analog Output 3
4	Analog Output 2	Analog Output 4
5		Analog Output 5
6	Analog Output 3	Analog Output 6
7		Analog Output 7
8	Analog Output 4	
9		
10	AnalogOutput 5	
11		
12	Analog Output 6	
13		
14	Analog Output 7	
15		

Examples:

MBA= ,4,2,4,array[] Request the status of Registers 2-5 (AO1 and AO2 if MI0, and AO2, AO3, AO4, AO5 if MI1). The response is stored in array[]

MG@AO[1002] Requests the status of analog output 2 (result is transmitted via ethernet or serial)

Packets:

The command `MBA=,4,2,4,array[]` results in the following packets being sent, when one RIO is the master, and another RIO-47100 is the slave, communicating over handle A, port 502(Modbus). When MI is set to 0 the response is given as volts in 32-bit Floating Point. When MI is set to 1 the response is given as counts in 16-bit decimal notation. Assume analog outputs in ascending order from 0-7 are: .5, 1, 1.5, 2, 2.5, 3, 3.5, 4

Request	<i>Slave MIO</i>			<i>Slave MII</i>			
	Field Name	(hex)	Response 32-bit Floating Point Field Name (hex)	Real Value (volts)	Response 16-bit decimal Field Name (hex)	Real Value (counts)	
Function	04	Function	04		Function	04	
Starting Address High	00	Byte Count	08		Byte Count	08	
Starting Address Low	02	RegVal2 High	3F	1.0000	RegVal2 High	4C	19661
Quantity of Registers High	00		80		RegVal2 Low	CD	
Quantity of Registers Low	04		00		RegVal3 High	66	26214
		RegVal2 Low	00		RegVal3 Low	66	
		RegVal3 High	3F	1.5000	RegVal4 High	80	32768
			C0		RegVal4 Low	00	
			00		RegVal5 High	99	39321
		RegVal3 Low	00		RegVal5 Low	99	

With the slave MI set to 0, the master RIO's arrays will look like this:

```
array[0]=16256
array[1]=0
array[2]=16320
array[3]=0
```

With the slave MI set to 1, the master RIO's arrays will look like this:

```
array[0]=19661
array[1]=26214
array[2]=32768
array[3]=39321
```

Function Code 5 (\$05) - Write Single Coil

Description

Modbus function code \$05 is a request to write a single coil. This will write a digital output of an RIO configured as a slave.

Operating as a master

The function code of the response can be queried with the `_MW` command. If an exception occurred, the exception code of the response can be queried with `_MW1`.

Example:

<u>Normal Response</u>	<u>Exception Response</u>
<code>_MW</code> results in \$05	<code>_MW</code> results in \$85
	<code>_MW1</code> contains \$01 or \$02

Ways to use Function Code 5 with Galil commands:

1. MB command in raw packet mode
2. MB command with Modbus function code 5
3. SB
4. CB
5. OB

Operating as a slave

The RIO will accept a write single coil request with a starting address ranging from \$0000-\$000F, referencing digital outputs 0-15.

The RIO will respond with a Modbus packet that is identical to the packet it received.

Coil Mapping

Coil	Addresses	Coil	Addresses
0	Digital Output 0	8	Digital Output 8
1	Digital Output 1	9	Digital Output 9
2	Digital Output 2	10	Digital Output 10
3	Digital Output 3	11	Digital Output 11
4	Digital Output 4	12	Digital Output 12
5	Digital Output 5	13	Digital Output 13
6	Digital Output 6	14	Digital Output 14
7	Digital Output 7	15	Digital Output 15

Examples:

For the following example, array[] contains [0,0,0,0,0,6,1,5,0,7,\$FF,\$00]

MBA= -1,12,array[] Request to set digital output 7 high

MBA=,5,7,1 Request to set digital output 7 high

SB1007 Request to set digital output 7 high

OB1007,@IN[1000] Request to set digital output 7 high if digital output 0 is high

Packets:

The command MBA=,5,7,1 results in the following packets being sent, when one RIO is the master, and another RIO is the slave, communicating over handle A, port 502(Modbus).

Request		Response	
Field Name	(hex)	Field Name	(hex)
Function	05	Function	05
Starting Address High	00	Starting Address High	00
Starting Address Low	07	Starting Address Low	07
Output Value High	FF	Output Value High	FF
Output Value Low	00	Output Value Low	00

As a result of the MB command above, the slave RIO will have output 7 turned on.

Function Code 6 (\$06) - Preset Single Register

Description

Modbus function code \$06 is a request to write to a single register. This will write all 16 digital outputs of an RIO configured as a slave.

Operating as a master

The function code of the response can be queried with the `_MW` command. If an exception occurred, the exception code of the response can be queried with `_MW1`.

Example:

Normal Response
`_MW` results in \$06

Exception Response
`_MW` results in \$86
`_MW1` contains \$01 or \$02

Ways to use function code 6 with Galil commands:

1. `MB` command in raw packet mode
2. `MB` command with Modbus function code 6

Operating as a slave

The RIO will accept a preset single register request with a starting address of \$0000. The register values can range from 0x0000 to 0xFFFF and correspond to a binary representation of the 16 digital outputs. The RIO will respond with a Modbus packet that is identical to the packet it received.

Coil Mapping

Coil	Addresses	Coil	Addresses
0	Digital Output 0	8	Digital Output 8
1	Digital Output 1	9	Digital Output 9
2	Digital Output 2	10	Digital Output 10
3	Digital Output 3	11	Digital Output 11
4	Digital Output 4	12	Digital Output 12
5	Digital Output 5	13	Digital Output 13
6	Digital Output 6	14	Digital Output 14
7	Digital Output 7	15	Digital Output 15

Examples:

For the following example, array[] contains [0,0,0,0,0,6,1,6,0,0,\$55,\$AA]

MBA= -1,12,array[] Request to write digital outputs 15-0 to \$55AA

MBA= ,6,0,\$55AA Request to write digital outputs 15-0 to \$55AA

Note: writing digital outputs 15-0 to \$55AA results in digital outputs 15-0 in descending order, being 0,1,0,1,0,1,0,1,0,1,0,1,0,1,0,1,0.

Packets:

The command MBA= ,6,0,\$55AA results in the following packets being sent, when one RIO is the master, and another RIO is the slave, communicating over handle A, port 502(Modbus).

Request		Response	
Field Name	(hex)	Field Name	(hex)
Function	06	Function	06
Starting Address High	00	Starting Address High	00
Starting Address Low	00	Starting Address Low	00
Register Value High	55	Register Value High	55
Register Value Low	AA	Register Value Low	AA

Function Code 7 (\$07) – Read Exception Status

Description

Modbus function code \$07 is a request to read the 8 exception status outputs. This will read digital outputs 0-7 of an RIO configured as a slave.

Operating as a master

The function code of the response can be queried with the `_MW` command. If an exception occurred, the exception code of the response can be queried with `_MW1`.

Example:

<u>Normal Response</u>	<u>Exception Response</u>
<code>_MW</code> results in \$07	<code>_MW</code> results in \$87
	<code>_MW1</code> contains \$01 or \$02

When using the MB command with Modbus function code \$07, response data will be stored in the array referenced in the command line.

Ways to use function code 7 with Galil commands:

1. MB command in raw packet mode
2. MB command with Modbus function code 7.

Operating as a slave

The RIO will accept a read exception status request. The RIO will respond with function code \$07, and will return 1 byte of output data ranging from \$00 to \$FF, with each bit representing the state of a digital output (1 or 0). The LSB of the output data byte is digital output 0, and the MSB of the output data byte is digital output 7.

Coil Mapping

Coil	Addresses
0	Digital Output 0
1	Digital Output 1
2	Digital Output 2
3	Digital Output 3
4	Digital Output 4
5	Digital Output 5
6	Digital Output 6
7	Digital Output 7

Examples:

MBA= ,7,array[] Request to read exception status

Packets:

The command MBA= ,7,array[] results in the following packets being sent, when one RIO is the master, and another RIO is the slave, communicating over handle A, port 502(Modbus). Assume digital outputs, in descending order from 15-0 are:0,1,0,1,0,1,0,1,1,0,1,0,1,0,1,0. (\$55AA)

Request		Response	
Field Name	(hex)	Field Name	(hex)
Function	07	Function	07
		Output Data	AA

array[0] on the master RIO will equal 170 in this example.

Function Code 15 (\$0F) – Write Multiple Coils

Description

Modbus function code (\$0F) is a request to write multiple coils. This will write multiple digital outputs to an RIO configured as a slave.

Operating as a master

The function code of the response can be queried with the `_MW` command. If an exception occurred, the exception code of the response can be queried with `_MW1`.

Example:

Normal Response
`_MW` results in \$0F

Exception Response
`_MW` results in \$8F
`_MW1` contains \$01 or \$02

Ways to use function code 15 with Galil commands:

1. `MB` command in raw packet mode
2. `MB` command with Modbus function code 15

Operating as a slave

The RIO will accept a write multiple coils request with a starting address ranging from \$0000-\$000F, referencing digital outputs 0-15. The RIO will accept a request for up to all 16 of its digital outputs, or \$0001-\$0010.

The RIO will respond with function code \$0F, a starting address field which matches the starting address field of the request packet, and a quantity of outputs which matches the quantity of outputs field of the request packet.

Coil Mapping

Coil	Addresses	Coil	Addresses
0	Digital Output 0	8	Digital Output 8
1	Digital Output 1	9	Digital Output 9
2	Digital Output 2	10	Digital Output 10
3	Digital Output 3	11	Digital Output 11
4	Digital Output 4	12	Digital Output 12
5	Digital Output 5	13	Digital Output 13
6	Digital Output 6	14	Digital Output 14
7	Digital Output 7	15	Digital Output 15

Examples:

For the following example, array[] contains [0,0,0,0,0,9,1,15,0,0,0,16,2,\$AA,\$55]

MBA= -1,15,array[] Request to write \$AA55 to digital outputs 15-0

For the following example, array[] contains [\$AA55]

MBA= ,15,0,16,array[] Request to write \$AA55 to digital outputs 15-0

Packets:

The command MBA= ,15,0,16,array[] (when array contains [\$AA55]) results in the following packets being sent, when one RIO is the master, and another RIO is the slave, communicating over handle A, port 502(Modbus). The slave RIO's outputs 15-0 will be set to the following (1 is on 0 is off):

Output	15	14	13	12	11	10	9	8	7	6	5	4	3	2	1	0
Value	0	1	0	1	0	1	0	1	1	0	1	0	1	0	1	0

Request		Response	
Field Name	(hex)	Field Name	(hex)
Function	15	Function	15
Starting Address High	00	Starting Address High	00
Starting Address Low	00	Starting Address Low	00
Quantity of Outputs High	00	Quantity of Outputs High	00
Quantity of Outputs Low	10	Quantity of Outputs Low	10
Byte Count	02		
Outputs Value High	AA		
Outputs Value Low	55		

Function Code 16 (\$10) – Write Multiple Registers

Description

Modbus function code (\$10) is a request to write multiple registers, also known as analog outputs

Operating as a master

The function code of the response can be queried with the `_MW` command. If an exception occurred, the exception code of the response can be queried with `_MW1`.

Example:

<u>Normal Response</u>	<u>Exception Response</u>
<code>_MW</code> results in \$10	<code>_MW</code> results in \$90
	<code>_MW1</code> contains \$01 or \$02

Ways to use function code 16 with Galil commands:

1. MB command in raw packet mode
2. MB command with Modbus function code 16
3. AO[x] See command reference for details

Note: The RIO acting as a master can write up to 123 registers at a time with function code 16 per the Modbus specification.

The Modbus transaction results are available with the `_MW` and `_MW1` commands.

Operating as a slave

The RIO will accept different starting address ranges for a write multiple registers request depending on the state of the MI command. If MI is set to 0 (register data is volts in 32-bit floating point), the RIO will accept an address range of \$0001-\$000E. If MI is set to 1 (register data is count in 16-bit decimal), the RIO will accept a write multiple registers request with an address range of \$0000-\$0007. The RIO will respond with function code 16, a 2 byte starting address field identical to the starting address field of the request packet, and a 2 byte quantity of registers field identical to the quantity of registers field of the request packet.

Galil Register Map

Register Address	32-Bit Floating Point	Counts
0	Analog Output 0	Analog Output 0
1		Analog Output 1
2	Analog Output 1	Analog Output 2
3		Analog Output 3
4	Analog Output 2	Analog Output 4
5		Analog Output 5
6	Analog Output 3	Analog Output 6
7		Analog Output 7
8	Analog Output 4	
9		
10	Analog Output 5	
11		
12	Analog Output 6	
13		
14	Analog Output 7	
15		

Examples:

For the following example, array[] contains [0,0,0,0,0,15,1,16,0,2,0,4,8,64,160,0,0,64,64,0,0]

MBA= -1,21,array[] Request to write 5V to analog output 1 and 3V to analog output 2

For the following example, array[] contains [\$40A0, \$0000, \$4040, \$0000] (\$40A00000 is 32-bit Floating Point for 5.0000 decimal and \$40400000 is 32-bit Floating Point for 3V decimal)

MBA= ,16,2,4,array[] Request to write 5V to analog output 1 and 3V to analog output 2

AO1001,5 Request to write 5V to analog output 1

Packets:

The command MBA= ,16,2,4,array[] results in the following packets being sent, when one RIO is the master, and another RIO is the slave, and array[] contains [\$40A0,\$0000,\$4040,\$0000], communicating over handle A, port 502(Modbus). MI is set to 0 on the slave.

Request			Response	
32-Bit Floating Point				
Field Name		(hex)	Field Name (hex)	
Function		10	Function	10
Starting Address Hi		0	Starting Address Hi 0	
Starting Address Lo		2	Starting Address Lo 2	
Quantity Outputs Hi		0	Quantity of Registers Hi 0	
Quantity Outputs Lo		4	Quantity of Registers Lo 4	
Byte Count		8		
RegVal0 High		40		
		A0		
		0		
RegVal0 Low		0		
RegVal1 High		40		
		40		
		0		
RegVal1 Low		0		

The slave RIO will have analog output 1 set to 5V and analog output 2 set to 3V

Example 2

The command MBA= ,16,2,2,array[] results in the following packets being sent, when one RIO is the master, and another RIO-47100 is the slave, and array[] contains [\$FFFF,\$9999,\$6666,\$3333], communicating over handle A, port 502(Modbus). MI is set to 1 on the slave.

Request			Response	
Counts				
Field Name		(hex)	Field Name (hex)	
Function		10	Function	10
Starting Address Hi		0	Starting Address Hi 0	
Starting Address Lo		2	Starting Address Lo 2	
Quantity Outputs Hi		0	Quantity of Registers Hi 0	
Quantity Outputs Lo		2	Quantity of Registers Lo 2	
Byte Count		4		
RegVal0 High		FF		
RegVal0 Low		FF		
RegVal1 High		99		
RegVal1 Low		99		

The slave RIO will have analog output 2 set to 5V and analog output 3 set to 3V

Analog IO Ranges

The analog inputs and outputs range from different values depending on the configuration of the RIO-471x0. This information is specifically important when using the RIO to communicate as a modbus slave and MI is set to 1.

RIO-47100

Analog Inputs

AQx,m(see command reference for details)

m	Analog Range	Counts Range(decimal)	Counts Range(hex)
0	0-5V	0-32572	0x0000 - 0x7FF0
1	+/-5V	0-32572	0x0000 - 0x7FF0

Analog Outputs

Analog Range	Counts Range(decimal)	Counts Range(hex)
0-5V	0-65520	0x0000 - 0xFFFF

RIO-47120 (12 or 16 bit version)

Analog Inputs

AQx,m(see command reference for details)

m	Analog Range	Counts Range(decimal)	Counts Range(hex)
1	+5V	-32768 to 32767	0x8000 - 0x7FFF
2	+/-10V	-32768 to 32767	0x8000 - 0x7FFF
3	0-5V	0-65535	0x0000 - 0xFFFF
4	0-10V	0-65535	0x0000 - 0xFFFF

Analog Outputs

DQx,m(see command reference for details)

m	Analog Range	Counts Range(decimal)	Counts Range(hex)
1	0-5V	0-65535	0x0000 - 0xFFFF
2	0-10V	0-65535	0x0000 - 0xFFFF
3	+/-5V	0-65535	0x0000 - 0xFFFF
4	+/-10V	0-65535	0x0000 - 0xFFFF

Data Record

QR and DR Commands

The RIO can provide a block of status information back to the host computer in a single Ethernet packet using either the QR or DR commands. The QR command returns the Data Record as a single response. The DR command causes the controller to send a periodic update of the Data Record out a dedicated UDP Ethernet handle. The Data Record response packet contains binary data that is a snapshot of the controller's I/O status.

Since the Data Record response contains all information in binary format; the result of this command cannot be displayed in a Galil terminal.

The QR and DR commands will return 4 bytes of header information, followed by an entire data record. A data record map is provided below.

RIO Data Record

DATA TYPE	ITEM
UB	1 st byte of header
UB	2 nd byte of header
UB	3 rd byte of header
UB	4 th byte of header
UW	Sample number
UB	Error Code
UB	General Status
UW	Analog Out Channel 0 (counts)
UW	Analog Out Channel 1 (counts)
UW	Analog Out Channel 2 (counts)
UW	Analog Out Channel 3 (counts)
UW	Analog Out Channel 4 (counts)
UW	Analog Out Channel 5 (counts)
UW	Analog Out Channel 6 (counts)
UW	Analog Out Channel 7 (counts)
UW*	Analog In Channel 0 (counts)
UW*	Analog In Channel 1 (counts)
UW*	Analog In Channel 2 (counts)
UW*	Analog In Channel 3 (counts)
UW*	Analog In Channel 4 (counts)
UW*	Analog In Channel 5 (counts)
UW*	Analog In Channel 6 (counts)
UW*	Analog In Channel 7 (counts)
UW	Output State
UW	Input State
UL	Pulse Count
SL	ZC data – user configurable variable
SL	ZD data – user configurable variable

Note: UB=Unsigned Byte, UW=Unsigned Word (2 bytes of “Little Endian”), SL=Signed Long Word

*These may be signed or unsigned words depending on the AQ setting on the RIO-4712x. For example, if the bytes received from the data record packet for analog input 0 were 00 80, it could have the following meaning, depending on AQ

Little Endian	AQ0,1	AQ0,2	AQ0,3	AQ0,4
80 00	-5 Volts	-10 Volts	2.5 Volts	5 Volts

This data can be broken up into sections. The **Data Record Map** includes the 4 bytes of header. The **General Data Block** consists of the sample number, the error code, and the general status. The **I/O Data Block** includes all the other items in the above table.

Explanation of Status Information

Header Information –

Bytes 0, 1 of Header:

The first two bytes of the data record provide the header information.

BIT 15	BIT 14	BIT 13	BIT 12	BIT 11	BIT 10	BIT 9	BIT 8
1	N/A	N/A	N/A	N/A	N/A	N/A	N/A
BIT 7	BIT 6	BIT 5	BIT 4	BIT 3	BIT 2	BIT 1	BIT 0
N/A	N/A	N/A	N/A	N/A	N/A	N/A	N/A

Bytes 2, 3 of Header:

Bytes 2 and 3 make up a word, which represents the Number of bytes in the data record, including the header. Byte 2 is the low byte, and byte 3 is the high byte.

Note: The header information of the data records is formatted in little endian.

General Status Information (1 Byte)

BIT 7	BIT 6	BIT 5	BIT 4	BIT 3	BIT 2	BIT 1	BIT 0
Program Running	N/A	N/A	N/A	N/A	Waiting for input from IN command	Trace On	Echo On

ZC and ZD Commands

Another important feature of the data record is that it contains two variables that can be set by the user. The ZC and ZD commands are responsible for these variables. Each variable can be a number, a mathematical equation, or a string. See the Command Reference for more information on the ZC and ZD commands.

Chapter 4 I/O

Introduction

The standard RIO controller has 16 digital inputs, 16 digital outputs, 8 analog inputs and 8 analog outputs. The interrogation command, **TZ**, allows the user to get a quick view of the I/O configuration and bit status.

Specifications

Access to I/O points is made through the 44pin and 26pin High Density D-Sub connectors on the top of the unit. Pinouts for the [Connectors for RIO-47xxx](#) are listed in the Appendix.

Digital Outputs

High Power Digital Outputs

On the RIO-471xx digital outputs 0-7 are opto-isolated sourcing power outputs. On the RIO-472xx all 16 of the digital outputs are configured this way by default. 12-24VDC with 500mA of current capability per output. The internal circuit diagram is shown in Figure 4:

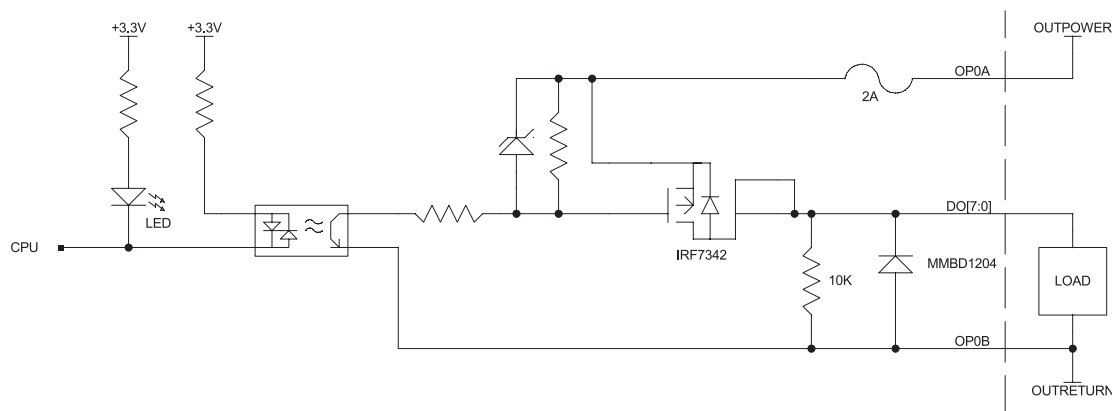

Figure 4: High Power Sourcing Outputs

OP0A should be connected to the positive side of a 12-24VDC external power supply.

OP0B should be connected to Ground on the external power supply

OP0A and OP0B are the Output Power for Bank 0. The device that needs to be turned on/off (solenoid, relay, etc...) should be connected with the positive side of the device connected to the digital output DO [7:0] and the negative side connected to the Ground of the power supply. When the SBn (Set Bit n) command is

given, this will provide a positive voltage to the device on the output pin to turn it on (with up to 500mA of current available). A CBn (Clear Bit n) will remove the voltage to turn it off. The **bold** connections in Figure 4 are external connections.

RIO-471xxx

There are two internal 2 Amp fuses for the high power outputs, one fuse for outputs 0-3 and another fuse for outputs 4-7. These fuses are not field-replaceable.

RIO-472xx

OP1A and OP1B are the Output Power for Bank 1 – digital outputs 8-15.

There are two internal 4 Amp fuses for the high power outputs, one fuse for outputs 0-7 (OP0A/OP0B), and another fuse for outputs 8-15 (OP1A/OP1B). These fuses are not field-replaceable.

Low Power Sinking Outputs

Digital Outputs 8-15 are opto-isolated sinking outputs on the RIO-471xx (by default none of the digital outputs on the RIO-472xx are configured this way). If ordered with -08-15 SOURCE option, please see the section below. 5-24VDC with 25mA of current capability in a sinking configuration.

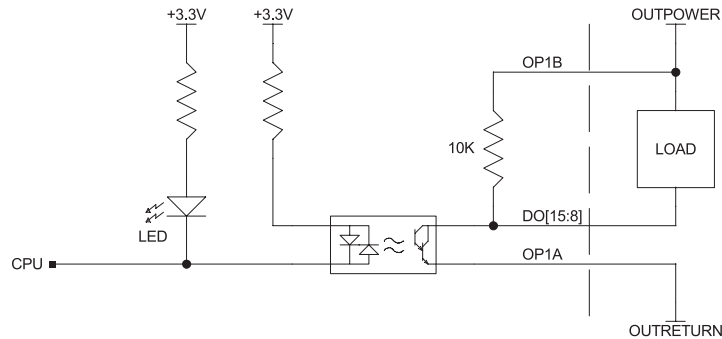

Figure 5: Low Power Sinking Outputs

OP1B should be connected to the positive side of a 5-24VDC external power supply.

OP1A should be connected to Ground on the external power supply.

OP1A and OP1B are the Output Power for Bank 1. The output can sink up to 25mA of current. The device should be connected between the digital output DO[15:8] and the positive side of the power supply. When current is **not** flowing through the opto-coupler (CB), the 10k resistor pulls-up the output pin to the voltage supplied to OP1B. When current **is** flowing through the opto-coupler (SB), the digital output drops to Ground (supplied by OP1A) and is able to sink up to 25mA of current. The **bold** connections in Figure 5 are external connections.

OUTC jumpers

The OUTC jumpers can be used when an external power supply is not desired for digital outputs 8-15. These low power outputs can use the internal +5V from the RIO instead. To do this, place a jumper on the pins labeled OUTC as shown here:

Note: These jumpers DO NOT supply power to high power digital outputs; an external supply is required for these outputs

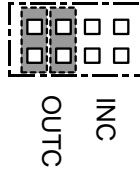

PWM Outputs

With firmware revisions Rev D and newer, Digital Outputs 14 and 15 can be setup independently as PWM outputs using the DY, FQ and PM commands. The standard opto-isolated outputs found on the RIO-47xxx will have a limited bandwidth (50Hz) that will not allow the full range of frequency and duty cycle available from the DY, FQ and PM commands. The RIO can be ordered with a -PWM option that will bypass the opto-isolated outputs and provide buffered outputs for DO14:15. See the -PWM section in the Appendix for more information.

Digital Inputs

Digital inputs 0-15 are opto-isolated inputs with a range of 5-24VDC. There is a 2.2k internal series resistor to INC0 (Input Common Bank 0) for inputs 0-7 and INC1 (Input Common Bank 1) for inputs 8-15. The series resistor limits the current through the PS2805 opto-coupler. The INC0 and INC1 can either be connected to the positive side of a DC power supply or to the Ground side of a DC power supply. When a device is connected to the digital input, current flowing through the opto-coupler will cause the input to turn on. The logic of the input can be configured using the IQ command.

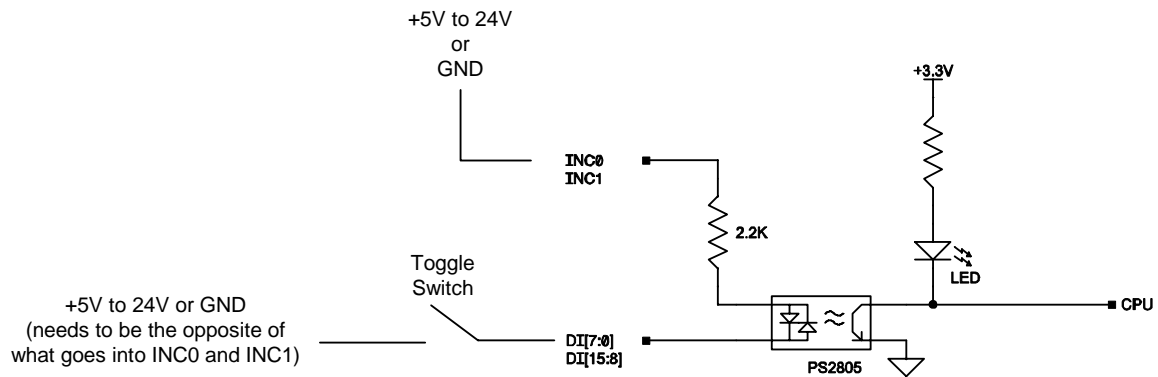
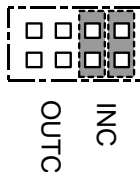

Figure 6: Digital Inputs

INC jumpers

The INC jumpers can be used when an external power supply is not desired for digital inputs 0-15. These inputs can use the internal +5V from the RIO instead. To do this, place a jumper on the pins labeled INC as shown here:



When using the INC jumpers, the digital inputs must have a reference. This reference comes from the RIO from pin 34 (INC0B) for inputs 0-7 and from pin 16 (INC1B) for inputs 8-15.

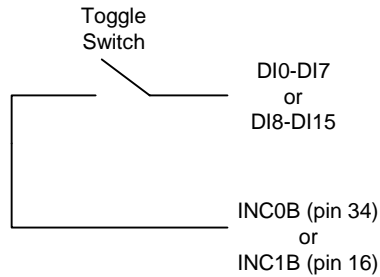

Pulse Counter Input

Digital input 3 (DI3) is a special purpose input that (when enabled) is used to count pulses coming in. To enable the pulse counter, the PC command must be issued with the following syntax:

PCn where

n=0 (default) input DI3 is a general purpose input

n=1 sets input DI3 to be a rising edge pulse counter (also clears the pulse counter)

n=-1 sets input DI3 to be a falling edge pulse counter (also clears the pulse counter)

n=? returns the status of the pulse counter (0 if disabled, 1 if enabled)

When the PC command is enabled, input DI3 will count high or low going edges. The operand `_PC` is used to report back the number of pulses counted. The maximum frequency of the input is limited by the optocouplers to 300 Hz. If a higher frequency is needed order the `-HS` option in the Appendix.

Expanded Memory RIO

When using the expanded memory RIO (RIO-47102, RIO-47122, RIO-47202) the Input 3 cannot be used as the Pulse Counter Input unless the `-HS` option is ordered.

Analog Outputs

RIO-4710x:

Analog Outputs 0-7 on the RIO-4710x are 12 bit analog outputs and have a voltage range of 0-5VDC. The outputs can sink or source up to 4mA of current.

RIO-4712x:

Analog Outputs 0-7 on the RIO-4712x have a configurable voltage range that is set using the DQ command. The default outputs have a 12bit DAC resolution (order RIO-4712x-16 for 16 bit resolution). The analog outputs can sink or source up to 4mA of current. **See the DQ command in the Command Reference for a full explanation.**

DQ	Analog Output Range
DQ 0,1	Sets AO0 to 0-5VDC
DQ 1,2	Sets AO1 to 0-10VDC
DQ 2,3	Sets AO2 to +/-5VDC
DQ 3,4	Sets AO3 to +/-10VDC

Analog Inputs

Each analog input goes through its own internal ADC (Analog to Digital Converter) but when differential mode is chosen – the inputs are treated as “pairs”. The difference of two analog inputs is the value reported by the controller. The same analog value is reported on both “pairs” of inputs. The table below shows how the differential channels are grouped. For instance, if AN0 is at 1.5VDC and AN1 is at 0VDC, a value of 1.5V is reported on @AN[0] and @AN[1].

Here’s the equation used to get the analog value for a sample pair of inputs (0 and 1).

$$AI_value = Input0 - Input1$$

RIO-4710x:

Analog Inputs 0-7 have a voltage range of 0-5VDC. They have 12bit ADC (a resolution of approximately 1.22mV) with a 100k input impedance.

Depending on the hardware configuration, the AQ command behaves differently. (Check the ID command to see what style of RIO hardware is installed.)

AQ	Differential Pairs
AQ 0,1	Input 0 & Input 1
AQ 2,1	Input 2 & Input 3
AQ 4,1	Input 4 & Input 5
AQ 6,1	Input 6 & Input 7

Table 1: Differential Analog Input Channels on RIO-4710x

RIO-4712x:

The default resolution for the RIO-4712x is 12bit with a 16bit option. The part number is RIO-4712x-16 for the 16 bit version.

Input Impedance:

Single Ended: 42k Ω
Differential: 31k Ω

Use the AQ command to specify the analog input range on the RIO-4712x.

AQ	Input Range
AQ 0,1	Set input 0 to have +/-5V input range
AQ 1,2	Set input 1 to have +/-10V input range
AQ 2,3	Set input 2 to have 0-5V input range
AQ 3,4	Set input 3 to have 0-10V input range

Table 2: Setting Input Ranges on RIO-4712x

On the RIO-4712x, the AQ command also allows the RIO to change the configuration from the default 8 single ended analog inputs to 4 differential analog inputs.

AQ	Differential Pairs
AQ 0,-1	Input 0 & Input 1 and +/-5V input range
AQ 2,-2	Input 2 & Input 3 and +/-10V input range
AQ 4,-3	Input 4 & Input 5 and 0-5V input range
AQ 6,-4	Input 6 & Input 7 and 0-10V input range

Table 3: Differential Analog Input Channels on RIO-4712x

RIO-472xx

The default resolution for the RIO-472xx is 12 bit with a 16 bit option. The part number is RIO-472xx-16 for the 16 bit version.

Input Impedance (default 12 bit):

Single Ended: 100k Ω

Input Impedance (With +-10V option)

Single Ended: 42k Ω

Differential: 31k Ω

See the AQ command in the command reference for a full explanation.

Analog Process Control Loop

A Process Control Loop allows closed loop control of a process or device. The RIO-471x0 has two independent PID filters to provide process control of two devices simultaneously. The RIO-471x2 has a total of 6 PID loops available. The default configuration for the RIO-472xx has no analog outputs and therefore 0 PID loops. If the RIO-472xx is ordered with analog outputs, then it will have 2 PID loops available. The set of commands shown in the table below are used to set the structure of the Process Control Loop.

Command	Description
AF	Analog Input for feedback
AZ	Analog Output for control
KP	Proportional Gain
KD	Derivative Gain
KI	Integral Gain
IL	Integrator Limit
DB	Deadband
CL	Control Loop Update Rate
PS	Commanded Setpoint
TE	Tell Error
AQ	Analog Input Range
DQ	Analog Output Range

*Note – All PID parameters are burnable except PS, DB, AQ, and DQ. If you issue a BN with the PID's enabled the default values for PS,DB,AQ, and DQ will be in effect upon power up.

To understand how a Process Control Loop works on the RIO, consider an example where it is desirable to control the temperature of an oven. The key items needed to do this are a heater, a temperature sensor, the oven itself, and a RIO unit to control the process. As shown in the diagram below, the heating element is coupled to the "System" which in this case is the oven. The temperature sensor provides feedback to the RIO in the form of an analog input. The RIO unit then compares the desired set-point (entered by the PS command) with the temperature sensor. The difference between the two is called the error "E". The error goes through a PID digital filter and then through a Digital to Analog Converter (DAC) which outputs a control voltage to the heater to close the loop.

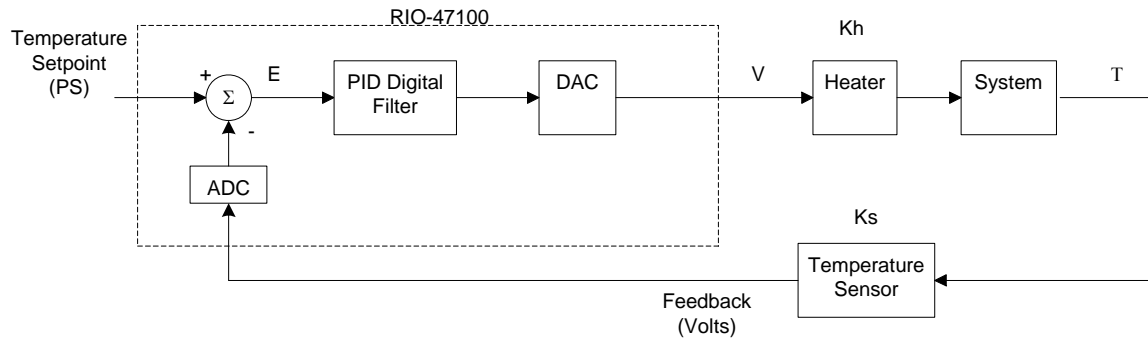

Figure 7: Process Control Loop

The example program below uses analog input 0 as the feedback from the temperature sensor and analog output 0 as the control voltage to the heater. An update rate of 25msec was set using the CL command, but a slower update rate could have been chosen due to the slow nature of temperature response. The PID values entered were experimentally found to provide optimum results based on the system. The desired set-point was chosen as 1V. A dead-band of 0.1V was added in order to prevent the system from responding to minor disturbances of the sensor.

```
#PCL
CL 25; '25msec update rate
AF 0; 'analog input 0 as feedback
AZ 0; 'analog output 0 as control
KP 1; 'proportional gain to 1
KD 10; 'derivative gain to 10
KI 0.5; 'integral gain to 0.5
DB 0.1; 'deadband of 0.1V
PS 1.8; 'set-point at 1.8V
```

Note: When the Process Control Loop is enabled, the Analog output voltage is normalized to half of the total voltage input. For instance, with a 0-5V analog input range such as the RIO-47100 – the voltage is normalized to 2.5V. This allows the output to go below 2.5 to compensate for a negative error and above 2.5V to compensate for positive error.

The AQ and DQ must be set on the RIO-47120 to configure the Analog input and output ranges before the process control loops are run and prior to setting AZ & AF. The range of the PS command is dependant on the AQ command.

Current vs Flow Control Mode

The PID loop on the RIO-47xxx by default works as a “current” mode loop. This means that when position error is 0 the analog output will also be set to zero.

Firmware revisions Rev D and newer allow the user to set a negative value for the DB command that will set the Process control loop into a flow control or velocity mode. When DB is set to a negative value, the analog output will be held at its current value and the PID’s will be held constant when the feedback is within the range set by the DB command. This mode is preferable for many fluid and temperature control applications.

Chapter 5 Programming

Overview

The RIO provides a versatile programming language that allows users to customize the RIO board for their particular application. Programs can be downloaded into the RIO memory, freeing up the host computer for other tasks. However, the host computer can send commands to the RIO at any time, even while a program is being executed.

In addition to commands that handle I/O, the RIO provides commands that allow it to make decisions. These commands include conditional jumps, event triggers, and subroutines. For example, the command `JP#LOOP, n<10` causes a jump to the label `#LOOP` if the variable `n` is less than 10.

For greater programming flexibility, the RIO provides user-defined variables, arrays, and arithmetic functions. The following sections in this chapter discuss all aspects of creating applications programs. The RIO-47xx0 program memory size is 200 lines x 40 characters. The RIO 47xx2 increases the memory size to a total of 400 lines x 40 characters.

Editing Programs

Use Galil software to enter programs in the Editor window. After downloading a program, use the `XQ` command to execute the program. The RIO also has an internal editor that may be used to create and edit programs in the RIOs memory. The internal editor is a rudimentary editor and is only recommended when operating with Galil's DOS utilities or through a simple RS-232 communication interface such as Windows Hyperterminal. See the `ED` command in the Command Reference for more info.

Program Format

A RIO program consists of instructions combined to solve a programmable logic application. Action instructions, such as setting and clearing I/O bits, are combined with Program Flow instructions to form the complete program. Program Flow instructions evaluate real-time conditions, such as elapsed time or input interrupts, and alter program flow accordingly.

A delimiter must separate each RIO instruction. Valid delimiters are the semicolon (`;`) or carriage return. The semicolon is used to separate multiple instructions on a single program line where the maximum number of characters on a line is 40 (including semicolons and spaces). A line continuation character (```) (below the `~` on a standard keyboard) allows a command to be continued on the next line in the case that 40 characters is not enough for a single command (see example at the end of this section).

Using Labels in Programs

All RIO programs must begin with a label and end with an End (EN) statement. Labels start with the number (#) sign followed by a maximum of seven characters. The first character must be a letter; after that, numbers are permitted. Spaces are not allowed.

The maximum number of labels that can be defined in the RIO-47xx0 is 62. The RIO-47xx2 increases this to a total of 126 labels.

Valid labels:

```
#BASICIO
#SQUARE
#X1
#input1
```

Invalid labels:

```
#1Square
#123
#PROGRAMMING          (longer than 7 characters)
```

Special Labels

The RIO also has some special labels, which are used to define input interrupt subroutines and command error subroutines. The following is a list of the automatic subroutines supported by the RIO. Sample programs for these subroutines can be found in the section *Automatic Subroutines for Monitoring Conditions*.

#AUTO	Automatic Program Execution on power up
#ININTn	Label for Input Interrupt subroutine
#CMDERR	Label for incorrect command subroutine
#TCPERR	Ethernet communication error

#AUTO is a special label for automatic program execution. A program which has been saved into the controller non-volatile memory using the BP (Burn Program) command can be automatically executed upon power up or reset by beginning the program with the label #AUTO.

Commenting Programs

Using an Apostrophe to Comment

The RIO provides an apostrophe (') for commenting programs. This character allows the user to include up to 39 characters on a single line after the apostrophe and can be used to include comments from the programmer as in the following example:

```
#OUTPUT
' PROGRAM LABEL
SB1; CB2
'Set Bit 1 and Clear Bit 2
EN; 'END OF PROGRAM
```

Note: The NO command also works to comment programs. The inclusion of the apostrophe or NO commands will require process time by the RIO board.

Using REM Statements with the Galil Terminal Software

When using Galil software to communicate with the RIO, REM, as in remark, statements may also be included. 'REM' statements begin with the word 'REM' and may be followed by any comments that are on

the same line. The Galil terminal software will remove these statements when the program is downloaded to the RIO board. For example:

```
#OUTPUT
REM PROGRAM LABEL
SB1;CB2;
REM Set Bit 1 and Clear bit 2
EN
REM END OF PROGRAM
```

Since the REM statements will be removed when the program is downloaded to RIO, be sure to keep a copy of the program with comments stored on the PC.

Program Lines Greater than 40 Characters

Line Continuation Character

A new character (`) {ascii character 96} has been included to allow a command in an application program to extend beyond the confines of the 40 character maximum line length.

```
#TEST
IF((var100=100)& (var101=50));MG"Condi`
tion satisfied";ELSE;MG"Stop";ENDIF
EN
```

This allows for

- a) more efficient command compressing
- b) the continuation of message commands (MG) on multiple lines.
- c) Longer IF, JP, & JS conditional statements

(Note: the total length of a multi-line command can not exceed 80 characters)

Lock Program Access using Password

The RIO can lock out user access to the internal program using the PW and {cntrl}L{cntrl}K commands. The PW sets the Password for the unit and the {cntrl}L{cntrl}K will lock the application program from being viewed or edited . The commands ED, UL, LS and TR will give privilege error #106 when the RIO is in a locked state. The program will still run when locked. The locked or unlocked state can be burned with the BN command. Once the program is unlocked, it remains accessible until a lock command or a reset (with the locked condition burned in) occurs. An example of how to lock the program is shown here:

```
:PW test, test
:^L^K test,1          1 locks, 0 unlocks
:LS
?
TC1
106 Privilege violation
```

Executing Programs - Multitasking

The RIO can run up to 4 independent programs or threads simultaneously. They are numbered 0 thru 3, where 0 is the main thread.

The main thread differs from the others in the following ways:

1. Only the main thread, thread 0, may use the input command, IN.
2. When interrupts are implemented for command errors, the subroutines are executed in thread 0. However for the #ININTn subroutines, the RIO has the ability to execute multiple input interrupts (#ININTn) on designated threads, not limited to the main thread. For more information, refer to the II command in the Command Reference.

To begin execution of the various programs, use the following instruction:

XQ #A,n

Where A represents the label and n indicates the thread number. To halt the execution of any thread, use the instruction

HX n

where n is the thread number.

Note that both the XQ and HX commands can be performed from within an executing program.

For example:

<u>Instruction</u>	<u>Interpretation</u>
#TASK1	Task1 label
AT0	Initialize reference time
CB1	Clear Output 1
#LOOP1	Loop1 label
AT 10	Wait 10 msec from reference time
SB1	Set Output 1
AT -40	Wait 40 msec from reference time, then initialize reference
CB1	Clear Output 1
JP #LOOP1	Repeat Loop1
#TASK2	Task2 label
XQ #TASK1,1	Execute Task1
#LOOP2	Loop2 label
WT20000	Wait for 20 seconds
HX1	Stop thread 1
MG"DONE"	Print Message
EN	End of Program

The program above is executed with the instruction XQ #TASK2,0 which designates TASK2 as the main thread (i.e. Thread 0). #TASK1 is executed within TASK2.

Debugging Programs

The RIO provides commands and operands that are useful in debugging application programs. These commands include interrogation commands to monitor program execution, determine the state of the RIO

board and the contents of the program, array, and variable space. Operands also contain important status information, which can help to debug a program.

Trace Commands

The trace command causes the RIO to send each line in a program to the host computer immediately prior to execution. Tracing is enabled with the command, TR1. TR0 turns the trace function off. Note: When the trace function is enabled, the line numbers as well as the command line will be displayed as each command line is executed. The program lines come back as unsolicited messages.

Error Code Command

When a program error occurs, the RIO halts the program execution at the point of the error. To display the last line number of program execution, issue the command, MG _ED.

The user can obtain information about the type of error condition that occurred by using the command TC1. This command returns a number and text message, which describe the error condition. The command TC0 (or TC) will return the error code without the text message. For more information about the command TC, see the Command Reference.

RAM Memory Interrogation Commands

For debugging the status of the program memory, array memory, or variable memory, the RIO has several useful commands. The command DM ? will return the number of array elements currently available. The command DA? will return the number of arrays that can be currently defined. For example, the RIO has a maximum of 400 array elements in up to 6 arrays. If a single array of 100 elements is defined, the command DM ? will return the value 250, and the command DA ? will return 5.

To list the contents of the variable space, use the interrogation command LV (List Variables). To list the contents of array space, use the interrogation command LA (List Arrays). To list the contents of the program space, use the interrogation command LS (List Program). To list the application program labels only, use the interrogation command LL (List Labels).

Operands

In general, all operands provide information that may be useful in debugging an application program. Below is a list of operands that are particularly valuable for program debugging. To display the value of an operand, the message command may be used. For example, since the operand, _ED, contains the last line of program execution, the command MG _ED will display this line number.

_ED contains the last line of program execution (useful to determine where program stopped)

_DL contains the number of available labels (62 max.)

_UL contains the number of available variables (126 max.)

_DA contains the number of available arrays (6 max.)

_DM contains the number of available array elements (400 max.)

Debugging Example:

The following program has an error. It attempts to set bit 14 high, but “SD” is used as the command instead of “SB”. When the program is executed, the RIO stops at line 001. The user can then query the RIO board using the command, TC1. The RIO responds with the corresponding explanation:

<u>Instruction</u>	<u>Interpretation</u>
:LS	List Program
000 #A	Program Label

001 SD14	Set bit 14 high
002 SB15	Set bit 15 high
003 MG"DONE"	Print message
004 EN	End
:XQ #A	Execute #A
?001 SD14	Error on Line 1
:TC1	Tell Error Code
130 Unrecognized Command	This command doesn't
:MG_ED	Print line number where problem occurred
1.00	The error occurred on line 1 of the program

Program Flow Commands

The RIO provides instructions to control program flow. The RIO program sequencer normally executes program instructions sequentially. The program flow can be altered with the use of interrupts and conditional jump statements.

Interrupts

To function independently from the host computer, the RIO can be programmed to make decisions based on the occurrence of an input interrupt, causing the RIO board to wait for multiple inputs to change their logic levels before jumping into a corresponding subroutine. Normally, in the case of a Galil controller, when an interrupt occurs, the main thread will be halted. However, in the RIO, the user can indicate in which thread (the thread must be already running when the interrupt occurs) the interrupt subroutine is to be run. When the interrupt occurs, the specified thread's main program will be paused to allow the interrupt subroutine to be executed. Therefore, the user has the choice of interrupting a particular thread execution upon an input interrupt (see II command). The input interrupt routines are specified using #ININTn where n can be 0-3. In this way, the RIO can make decisions based on its own I/O status without intervention from a host computer. The Return from Interrupt (RI) command is used to return from this subroutine to the place in the program where the interrupt had occurred. If it is desired to return to somewhere else in the program after the execution of the #ININTn subroutine, the Zero Stack (ZS) command is used, followed by unconditional jump statements.

Note: When using multiple II commands in a program, each II command must point to a unique label and must activate on an unused thread. Two or more II commands cannot be set to execute on the same thread, nor can multiple II commands be pointed to the same #ININTn label. Please see the II command in the RIO-47xxx command reference for more details.

Examples:

Interrupt

<u>Instruction</u>	<u>Interpretation</u>
#A	Program Label
XQ#B,1	Execute #B in thread 1
II1,0,-1&3	#ININT1 in thread 0 when input 1 low and input 3 high
II2,1,-5&10	#ININT2 in thread 1 when input 5 low and input 10 high
AI 13&14	Trippoint on inputs 13 and 14
#LOOP;JP#LOOP	Pseudo program – Loop indefinitely
EN	End program
#B	Program Label
AI 7&-8	Trippoint on inputs 7 and 8
#LOOP2	
SB10	Set bit 10 high
WT500	Wait for half a second
CB10	Set bit 10 low
WT500	Wait for 500msec
JP#LOOP2	Create a ‘light-blinker’ effect
EN	End program
#ININT1	Input interrupt program label
MG”Loop stops”	Print message, saying loop program in main thread halted
RI0	Return to main program without restoring trippoint, but keeping the interrupt enabled
#ININT2	
MG”Blinker stops”	Print message, saying blinker effect in thread 1 halted, since #ININT2 runs in thread 1
WT10000	Wait 10 seconds for user to reset inputs 5 and 10
RI1,1	Return to thread 1’s main program (blinker continues) while restoring trippoint on inputs 5 and 10; interrupt disabled

Note: This multitasking program can be executed with the instruction XQ #A,0 designating A as the main thread (i.e. Thread 0). #B is executed within A.

Event Trigger

This example waits for input 1 to go low and input 3 to go high, and then execute the TZ interrogation command. **Note:** The AI command actually halts execution of the program until the input occurs. If you do not want to halt the program sequences, use the Input Interrupt function (II) or a conditional jump on an input, such as:

JP #GO,(@IN[1] = 0) | (@IN[3] = 1).

<u>Instruction</u>	<u>Interpretation</u>
#INPUT	Program Label
AI-1&3	Wait for input 1 low and input 3 high
TZ	List the entire I/O status
EN	End program

Conditional Jumps

The RIO provides Conditional Jump (JP) and Conditional Jump to Subroutine (JS) instructions for branching to a new program location based on a specified condition. The conditional jump determines if a condition is satisfied and then branches to a new location or subroutine. Unlike event triggers such as the AI command, the conditional jump instruction does not halt the program sequence. Conditional jumps are useful for testing events in real-time. They allow the RIO to make decisions without a host computer.

Command Format - JP and JS

Format	Description
JS destination, logical condition	Jump to subroutine if logical condition is satisfied
JP destination, logical condition	Jump to location if logical condition is satisfied

The destination is a program line number or label where the program sequencer will jump if the specified condition is satisfied. Note that the line number of the first line of program memory is 0. The comma designates "IF". The logical condition tests two operands with logical operators.

Logical operators:

Operator	Description
<	less than
>	greater than
=	equal to
<=	less than or equal to
>=	greater than or equal to
<>	not equal

Conditional Statements

The conditional statement is satisfied if it evaluates to any value other than zero. The conditional statement can be any valid RIO numeric operand, including variables, array elements, numeric values, functions, keywords, and arithmetic expressions. If no conditional statement is given, the jump will always occur.

Examples:

Number	V1=6
Numeric Expression	V1=V7*6 @ABS[V1]>10
Array Element	V1<Count[2]
Variable	V1<V2
Internal Variable	_TI1=255 _DM<100
I/O	V1>@IN[2] @IN[1]=0

Multiple Conditional Statements

The RIO will accept multiple conditions in a single jump statement. The conditional statements are combined in pairs using the operands “&” and “|”. The “&” operand between any two conditions, requires that both statements be true for the combined statement to be true. The “|” operand between any two conditions requires that only one statement be true for the combined statement to be true.

Note: Each condition must be placed in parentheses for proper evaluation by the RIO. In addition, the RIO executes operations from left to right.

For example, using variables named V1, V2, V3 and V4:

JP #TEST, (V1<V2) & (V3<V4)

In this example, this statement will cause the program to jump to the label #TEST if V1 is less than V2 and V3 is less than V4. To illustrate this further, consider this same example with an additional condition:

JP #TEST, ((V1<V2) & (V3<V4)) | (V5<V6)

This statement will cause the program to jump to the label #TEST under two conditions: 1) If V1 is less than V2 AND V3 is less than V4. OR 2) If V5 is less than V6.

Using the JP Command:

If the condition for the JP command is satisfied, the RIO branches to the specified label or line number and continues executing commands from this point. If the condition is not satisfied, the RIO board continues to execute the next commands in sequence.

Instruction

Interpretation

JP #Loop,COUNT<10	Jump to #Loop if the variable, COUNT, is less than 10
JS #MOVE2,@IN[1]=1	Jump to subroutine #MOVE2 if input 1 is logic level high. After the subroutine MOVE2 is executed, the program sequencer returns to the main program location where the subroutine was called.
JP #BLUE,@ABS[V2]>2	Jump to #BLUE if the absolute value of variable, V2, is greater than 2
JP #C,V1*V7<=V8*V2	Jump to #C if the value of V1 times V7 is less than or equal to the value of V8*V2
JP#A	Jump to #A

Using If, Else, and Endif Commands

The RIO provides a structured approach to conditional statements using IF, ELSE and ENDIF commands.

Using the IF and ENDIF Commands

An IF conditional statement is formed by the combination of an IF and ENDIF command. The IF command has arguments of one or more conditional statements. If the conditional statement(s) evaluates true, the command interpreter will continue executing commands which follow the IF command. If the conditional statement evaluates false, the RIO will ignore commands until the associated ENDIF command is executed OR an ELSE command occurs in the program (see discussion of ELSE command below).

Note: An ENDIF command must always be executed for every IF command that has been executed.

Using the ELSE Command

The ELSE command is an optional part of an IF conditional statement and allows for the execution of commands only when the argument of the IF command evaluates False. The ELSE command must occur after an IF command and has no arguments. If the argument of the IF command evaluates false, the RIO will skip commands until the ELSE command. If the argument for the IF command evaluates true, the RIO board will execute the commands between the IF and ELSE commands.

Nesting IF Conditional Statements

The RIO allows for IF conditional statements to be included within other IF conditional statements. This technique is known as 'nesting' and the RIO allows up to 255 IF conditional statements to be nested. This is a very powerful technique allowing the user to specify a variety of different cases for branching.

Command Format - IF, ELSE and ENDIF

Function	Condition
IF conditional statement(s)	Execute commands proceeding IF command (up to ELSE command) if conditional statement(s) is true, otherwise continue executing at ENDIF command or optional ELSE command.
ELSE	Optional command. Allows for commands to be executed when argument of IF command evaluates not true. Can only be used with IF command.
ENDIF	Command to end IF conditional statement. Program must have an ENDIF command for every IF command.

Example using IF, ELSE and ENDIF:

<u>Instruction</u>	<u>Interpretation</u>
#TEST	Begin Main Program "TEST"
#LOOP	Begin loop inside main program

<pre> TEMP=@IN[1]@IN[2] JS#COND, TEMP=1 JP#LOOP EN #COND IF (@IN[1]=0) IF (@IN[2]=0) MG "INPUT 1 AND INPUT 2 ARE INACTIVE" ELSE MG "ONLY INPUT 1 IS ACTIVE" ENDIF ELSE MG"ONLY INPUT 2 IS ACTIVE" ENDIF #WAIT JP#WAIT,(@IN[1]=0) & (@IN[2]=0) EN </pre>	<pre> TEMP is equal to 1 if either Input 1 or Input 2 is high Jump to subroutine if TEMP equals 1 Loop back if TEMP doesn't equal 1 End of main program Begin subroutine "COND" IF conditional statement based on input 1 2nd IF conditional statement executed if 1st IF conditional true Message to be executed if 2nd IF conditional is true ELSE command for 2nd IF conditional statement Message to be executed if 2nd IF conditional is false End of 2nd conditional statement ELSE command for 1st IF conditional statement Message to be executed if 1st IF conditional statement End of 1st conditional statement Label to be used for a loop Loop until both input 1 and input 2 are not active End of subroutine </pre>
--	--

Stack Manipulation

It is possible to manipulate the subroutine stack by using the ZS command. Every time a JS instruction, interrupt or automatic routine (such as #ININTn or #CMDERR) is executed, the subroutine stack is incremented by 1 (up to a maximum of 16). Normally the stack is restored with an EN instruction. Occasionally it is desirable not to return back to the program line where the subroutine or interrupt was called. The ZS1 command clears 1 level of the stack. This allows the program sequencer to continue to the next line. The ZS0 command resets the stack to its initial value. For example, if an interrupt occurs and the #ININT1 routine is executed, it may be desirable to restart the program sequence instead of returning to the location where the interrupt occurred. To do this, give a ZS (ZS0) command at the end of the #ININT1 routine.

Auto-Start Routine

The RIO has a special label for automatic program execution. A program that has been saved into the RIO non-volatile memory can be automatically executed upon power up or reset, simply by beginning the program with the label #AUTO.

Note: The program must be saved into non-volatile memory using the command, BP.

Automatic Subroutines for Monitoring Conditions

Often it is desirable to monitor certain conditions continuously without tying up the host or RIO program sequences. The RIO can monitor several important conditions in the background. These conditions include checking for the occurrence of a defined input, position error, a command error, or an Ethernet communication error. Automatic monitoring is enabled by inserting a special, predefined label in the applications program. The pre-defined labels are:

SUBROUTINE	DESCRIPTION
#AUTO	Automatic Program Execution on power up
#AUTOERR	Automatic Program Execution on power up if error condition occurs
#ININTn	Input specified by II goes low (n from 0 to 3)
#CMDERR	Bad command given

#TCPERR	Ethernet communication error
#COMINT	Communication Interrupt Routine

For example, the #ININT label could be used to designate an input interrupt subroutine. When the specified input occurs, the program will be executed automatically.

NOTE: An application program must be running for automatic monitoring to function.

Example - Input Interrupt

Instruction	Interpretation
#A	Label
II0,0,1	Input Interrupt on 1
#LOOP;JP#LOOP;EN	Loop
#ININT0	Input Interrupt
MG "INPUT 1 IS HIGH"	Send Message to screen
RI0	Return from interrupt routine to Main Program and do not re-enable trippoints

Example - Command Error

Instruction	Interpretation
#BEGIN	Begin main program
IN "ENTER THE OUTPUT (0-15)", OUT	Prompt for output number
SB OUT	Set the specified bit
JP #BEGIN	Repeat
EN	End main program
#CMDERR	Command error utility
JP#DONE,_ED<>3	Check if error on line 3
JP#DONE,_TC<>6	Check if out of range
MG "VALUE OUT OF RANGE"	Send message
MG "TRY AGAIN"	Send message
ZS1	Adjust stack
JP #BEGIN	Return to main program
#DONE	End program if other error
ZS0	Zero stack
EN	End program

The above program prompts the operator to enter the output port to set. If the operator enters a number out of range (greater than 15), the #CMDERR routine will be executed prompting the operator to enter a new number.

In multitasking applications, there is an alternate method for handling command errors from different threads. Using the XQ command along with the special operands described below allows the controller to either skip or retry invalid commands.

OPERAND	FUNCTION
_ED1	Returns the number of the thread that generated an error
_ED2	Retry failed command (operand contains the location of the failed command)
_ED3	Skip failed command (operand contains the location of the command after the failed command)

The operands are used with the XQ command in the following format:

XQ_ED2 (or _ED3),_ED1,1

Where the “,1” at the end of the command line indicates a restart; therefore, the existing program stack will not be removed when the above format executes.

The following example shows an error correction routine that uses the operands.

Example - Command Error w/Multitasking

Instruction	Interpretation
#A	Begin thread 0 (continuous loop)
JP#A	
EN	End of thread 0
#B	Begin thread 1
N=17	Create new variable
SB N	Set the 17th bit, an invalid value
TY	Issue invalid command
EN	End of thread 1
#CMDERR	Begin command error subroutine
IF _TC=6	If error is out of range (SB 8)
N=1	Set N to a valid number
XQ_ED2,_ED1,1	Retry SB N command
ENDIF	
IF _TC=1	If error is invalid command (TY)
XQ_ED3,_ED1,1	Skip invalid command
ENDIF	
EN	End of command error routine

Example – Ethernet Communication Error

This simple program executes in the RIO and indicates (via the serial port) when a communication handle fails. By monitoring the serial port, the user can re-establish communication if needed.

<u>Instruction</u>	<u>Interpretation</u>
#LOOP	Simple program loop
JP#LOOP	
EN	
#TCPERR	Ethernet communication error auto routine
MG {P1}_IA4	Send message to serial port indicating which handle did not receive proper acknowledgment.
RE	Return to main program

Note: The #TCPERR routine only detects the loss of TCP/IP Ethernet handles, not UDP.

Mathematical and Functional Expressions

Mathematical Operators

For manipulation of data, the RIO provides the use of the following mathematical operators:

Operator	Function
+	Addition
-	Subtraction
*	Multiplication
/	Division
&	Logical And (Bit-wise)
	Logical Or (On some computers, a solid vertical line appears as a broken line)
()	Parenthesis
%	Modulus

The numeric range for addition, subtraction and multiplication operations is +/-2,147,483,647.9999. The precision for division is 1/65,000.

Mathematical operations are executed from left to right. Calculations within parentheses have precedence.

Examples:

SPEED=7.5*V1/2	The variable, SPEED, is equal to 7.5 multiplied by V1 and divided by 2
COUNT=COUNT+2	The variable, COUNT, is equal to the current value plus 2.
RESULT=Val1 - (@COS[45]*40)	Puts the value of Val1 - 28.28 in RESULT. 40 * cosine of 45° is 28.28
K=@IN[1]&@IN[2]	K is equal to 1 only if Input 1 and Input 2 are high

Note: Mathematical operations can be done in hexadecimal as well as decimal. Just precede hexadecimal numbers with a \$ sign so that the RIO recognizes them as such.

Bit-Wise Operators

The mathematical operators & and | are bit-wise operators. The operator, &, is a Logical And. The operator, |, is a Logical Or. These operators allow for bit-wise operations on any valid RIO numeric operand, including variables, array elements, numeric values, functions, keywords, and arithmetic expressions. The bit-wise operators may also be used with strings. This is useful for separating characters from an input string. When using the input command for string input, the input variable will hold up to 6 characters. These characters are combined into a single value, which is represented as 32 bits of integer and 16 bits of fraction. Each ASCII character is represented as one byte (8 bits), therefore the input variable can hold up to six characters. The first character of the string will be placed in the top byte of the variable and the last character will be placed in the lowest significant byte of the fraction. The characters can be individually separated, by using bit-wise operations as illustrated in the following example:

<u>Instruction</u>	<u>Interpretation</u>
#TEST	Begin main program
IN "ENTER",LEN{S6}	Input character string of up to 6 characters into variable 'LEN'
FLEN=@FRAC[LEN]	Define variable 'FLEN' as fractional part of variable 'LEN'
FLEN=\$10000*FLEN	Shift FLEN by 32 bits (IE - convert fraction, FLEN, to integer)
LEN1=(FLEN&\$00FF)	Mask top byte of FLEN and set this value to variable 'LEN1'
LEN2=(FLEN&\$FF00)/\$100	Let variable, 'LEN2' = top byte of FLEN
LEN3=LEN&\$000000FF	Let variable, 'LEN3' = bottom byte of LEN
LEN4=(LEN&\$0000FF00)/\$100	Let variable, 'LEN4' = second byte of LEN
LEN5=(LEN&\$00FF0000)/\$1000	Let variable, 'LEN5' = third byte of LEN
0	
LEN6=(LEN&\$FF000000)/\$1000000	Let variable, 'LEN6' = fourth byte of LEN
MG LEN6 {S4}	Display 'LEN6' as string message of up to 4 chars
MG LEN5 {S4}	Display 'LEN5' as string message of up to 4 chars
MG LEN4 {S4}	Display 'LEN4' as string message of up to 4 chars
MG LEN3 {S4}	Display 'LEN3' as string message of up to 4 chars
MG LEN2 {S4}	Display 'LEN2' as string message of up to 4 chars
MG LEN1 {S4}	Display 'LEN1' as string message of up to 4 chars
EN	

This program will accept a string input of up to 6 characters, parse each character, and then display each character. Notice also that the values used for masking are represented in hexadecimal (as denoted by the preceding '\$'). For more information, see the section on *Sending Messages* (page 69).

To illustrate further, if the user types in the string "TESTME" at the input prompt, the RIO will respond with the following:

T	Response from command MG LEN6 {S4}
E	Response from command MG LEN5 {S4}
S	Response from command MG LEN4 {S4}
T	Response from command MG LEN3 {S4}
M	Response from command MG LEN2 {S4}
E	Response from command MG LEN1 {S4}

Functions

Function	Description
@SIN[n]	Sine of n (n in degrees, with range of -32768 to 32767 and 16-bit fractional resolution)
@COS[n]	Cosine of n (n in degrees, with range of -32768 to 32767 and 16-bit fractional resolution)
@TAN[n]	Tangent of n (n in degrees, with range of -32768 to 32767 and 16-bit fractional resolution)
@ASIN[n]*	Arc Sine of n, between -90° and +90°. Angle resolution in 1/64000 degrees.
@ACOS[n]*	Arc Cosine of n, between 0 and 180°. Angle resolution in 1/64000 degrees.
@ATAN[n]*	Arc Tangent of n, between -90° and +90°. Angle resolution in 1/64000 degrees
@COM[n]	1's Complement of n
@ABS[n]	Absolute value of n
@FRAC[n]	Fraction portion of n
@INT[n]	Integer portion of n
@RND[n]	Round of n (Rounds up if the fractional part of n is .5 or greater)
@SQR[n]	Square root of n (Accuracy is +/- .004)
@IN[n]	Return digital input at general input n (where n starts at 0)
@OUT[n]	Return digital output at general output n (where n starts at 0)
@AN[n]	Return analog input at general input n (where n starts at 0)
@AO[n]	Return analog output at general output n (where n starts at 0)

*: These functions are multi-valued. An application program may be used to find the correct band.

Functions may be combined with mathematical expressions. The order of execution of mathematical expressions is from left to right and can be over-ridden by using parentheses.

Examples:

V1=@ABS[V7]	The variable, V1, is equal to the absolute value of variable V7.
V2=5*@SIN[POS]	The variable, V2, is equal to five times the sine of the variable, POS.
V3=@IN[1]	The variable, V3, is equal to the digital value of input 1.

Variables

For applications that require a parameter that is variable, the RIO-47xx0 board provides 126 variables. The RIO-47xx2 increases this to 254 total available variables. These variables can be numbers or strings. A program can be written in which certain parameters, such as I/O status or particular I/O bit, are defined as variables. The variables can later be assigned by the operator or determined by program calculations.

Example:

SB Red	Uses variable "Red" in SB command
input1=_@IN[1]	Assigns value of digital input 1 status to variable "input1"

Programmable Variables

The RIO allows the user to create up to 126 variables. Each variable is defined by a name, which can be up to eight characters. The name must start with an alphabetic character, however, and numbers are permitted in the rest of the name. *Spaces are not permitted.* Variable names should not be the same as RIO instructions. For example, RS is not a good choice for a variable name.

Examples of valid and invalid variable names are:

Valid Variable Names

STATUS1

TEMP1

POINT

Invalid Variable Names

REALLONGNAME ; Cannot have more than 8 characters

123 ; Cannot begin variable name with a number

STAT Z ; Cannot have spaces in the name

Assigning Values to Variables:

Assigned values can be numbers, internal variables and keywords, functions, RIO board parameters and strings; the range for numeric variable values is 4 bytes of integer (2^{31}) followed by two bytes of fraction (+/- 2,147,483,647.9999).

Numeric values can be assigned to programmable variables using the equal sign.

Any valid RIO functions can be used to assign a value to a variable. For example, `s1=@ABS[V2]` or `s2=@IN[1]`. Arithmetic operations are also permitted.

To assign a string value, the string must be in quotations. String variables can contain up to six characters that must be in quotation.

Examples:

<code>INTWO=_TI2</code>	Assigns returned value from TI2 command to variable INTWO.
<code>INPUT=@IN[1]</code>	Assigns logical value of input 1 to variable INPUT
<code>V2=V1+V3*V4</code>	Assigns the value of V1 plus V3 times V4 to the variable V2.
<code>Var="CAT"</code>	Assign the string CAT to variable Var

Displaying the value of variables at the terminal

Variables may be sent to the screen using the format, `variable=`. For example, `V1=` , returns the value of the variable V1. `V1=?` or `MG V1` are also valid ways of displaying a variable.

Operands

Operands allow status parameters of the RIO to be incorporated into programmable variables and expressions. Most RIO commands have an equivalent operand - which are designated by adding an underscore (`_`) prior to the command (see command reference).

Examples of Internal Variables:

<code>IN1=@IN[1]</code>	Assigns value of input 1 to the variable IN1.
<code>JP #LOOP,@AN[0]<2</code>	Jump to #LOOP if analog input 0 is less than 2
<code>JP #ERROR,_TC=1</code>	Jump to #ERROR if the error code equals 1.

Operands can be used in an expression and assigned to a programmable variable, but they cannot be assigned a value. For example: `_TI0=1` is invalid.

Special Operands (Keywords)

The RIO provides a few additional operands that give access to internal variables that are not accessible by standard RIO commands.

Operand	Function
<code>_BN</code>	*Returns serial # of the board.
<code>_DA</code>	*Returns the number of arrays available
<code>_DL</code>	*Returns the number of available labels for programming
<code>_DM</code>	*Returns the available array memory
<code>_UL</code>	*Returns the number of available variables
<code>TIME</code>	Free-Running Real Time Clock (Resets with power-on). Note: <code>TIME</code> does not use an underscore character (<code>_</code>) as other keywords.

*: All these keywords have corresponding commands except for `TIME`.

Examples of Keywords:

```
V1=_DA           Assign V1 the number of available array names
V3=TIME         Assign V3 the current value of the time clock
```

Arrays

For storing and collecting numerical data, the RIO-47xx0 provides array space for 400 elements. This number is increased to 1000 array elements on the RIO-47xx2. The arrays are one-dimensional, and up to 6 different arrays may be defined. Each array element has a numeric range of 4 bytes of integer (2^{31}) followed by two bytes of fraction (+/-2,147,483,647.9999). Arrays can be used to capture real-time data, such as the bit status of a particular I/O bank.

Defining Arrays

An array is defined with the command `DM`. The user must specify a name and the number of entries to be held in the array. An array name can contain up to eight characters, starting with an uppercase alphabetic character. The number of entries in the defined array is enclosed in [].

Example:

```
DM IOSTAT[100]   Defines an array names IOSTAT with 100 entries
DA *[]          Frees array space using Deallocate command
```

Assignment of Array Entries

Like variables, each array element can be assigned a value. Assigned values can be numbers or returned values from instructions, functions and keywords.

Array elements are addressed starting at count 0. For example, the first element in the `OUTPUT` array (defined with the `DM` command, `DM OUTPUT[7]`) would be specified as `OUTPUT[0]`.

Values are assigned to array entries using the equal sign. Assignments are made one element at a time by specifying the element number with the associated array name.

NOTE: Arrays must be defined using the command, `DM`, before assigning entry values.

Examples:

DM OUTPUT[10]	Dimension Output Array
OUTPUT[1]=3	Assigns the second element of the array, OUTPUT, the value of 3.
OUTPUT[1]=	Returns array element value
OUTPUT[9]=_TI0	Assigns the 10th element of the array, OUTPUT, the value for bank 0 digital inputs
data [2]=@COS[POS]*2	Assigns the third element of the array "data" the cosine of the variable POS multiplied by 2.
TIMER[1]=TIME	Assigns the second element of the array timer the returned value of the TIME keyword.

Using a Variable to Address Array Elements

An array element number can also be a variable. This allows array entries to be assigned sequentially using a counter.

For example:

<u>Instruction</u>	<u>Interpretation</u>
#A	Begin Program
COUNT=0;DM POS[10]	Initialize counter and define array
#LOOP	Begin loop
WT 10	Wait 10 msec
INPUT[COUNT]=_TI0	Record bank 0's input bit value into array element
INPUT[COUNT]=	Report input bit value
COUNT=COUNT+1	Increment counter
JP #LOOP,COUNT<10	Loop until 10 elements have been stored
EN	End Program

The above example records 10 input bit values for bank 0 at a rate of one value per 10 msec. The values are stored in an array named INPUT. The variable, COUNT, is used to increment the array element counter. The above example can also be executed with the automatic data capture feature described below.

Uploading and Downloading Arrays to On Board Memory

Arrays may be uploaded and downloaded using the QU and QD commands.

```
QU array[,start,end,delim
```

```
QD array[,start,end
```

where array is an array name such as A[].

Start is the first element of array (default=0)

End is the last element of array (default=last element)

Delim specifies whether the array data is separated by a comma (delim=1) or a carriage return (delim=0).

The file is terminated using <control>Z, <control>Q, <control>D or \.

Automatic Data Capture into Arrays

The RIO provides a special feature for automatic capture of data such as inputs or outputs. Up to four types of data can be captured and stored in four arrays. The capture rate or time interval may be specified. Recording can be done as a one-time event or as a circular continuous recording.

Command Summary - Automatic Data Capture

Command	Description
RA n[],m[],o[],p[]	Selects up to four arrays for data capture. The arrays must be defined with the DM command.
RD type1,type2,type3,type4	Selects the type of data to be recorded, where type1, type2, type3, and type 4 represent the various types of data (see table below). The order of data type is important and corresponds with the order of n,m,o,p arrays in the RA command.
RC n,m	The RC command begins data collection. Sets data capture time interval where n is an integer between 1 and 8 and designates 2 ⁿ msec between data. m is optional and specifies the number of elements to be captured. If m is not defined, the number of elements defaults to the smallest array defined by DM. When m is a negative number, the recording is done continuously in a circular manner. _RD is the recording pointer and indicates the address of the next array element. n=0 stops recording.
RC?	Returns a 0 or 1 where, 0 denotes not recording, 1 specifies recording in progress

Data Types for Recording:

Data type	Description
_TIn	Inputs at bank n (0 or 1)
_OPn	Output bank n status (0 or 1)
_AFn	Analog input status (0-7)
_AOn	Analog output status (0-7)

Operand Summary - Automatic Data Capture

_RC	Returns a 0 or 1 where, 0 denotes not recording, 1 specifies recording in progress
_RD	Returns address of next array element.

Deallocating Array Space

Array space may be deallocated using the DA command followed by the array name. DA*[0] deallocates all the arrays.

Input of Data (Numeric and String)

Input of Data

The command, IN, is used to prompt the user to input numeric or string data. Using the IN command, the user may specify a message prompt by placing a message in quotations. When the RIO executes an IN command, it will wait for the input of data. The input data is assigned to the specified variable or array element.

Note: The IN command is only valid when communicating through RS232. This command will not work through the Ethernet.

An Example for Inputting Numeric Data

```
#A
IN "Enter output number", OUT
EN
```

In this example, the message "Enter output number" is displayed on the computer screen. The RIO board waits for the operator to enter a value. The operator enters the numeric value that is then assigned to the variable, OUT.

Inputting String Variables

String variables with up to six characters may input using the specifier, {Sn} where n represents the number of string characters to be input. If n is not specified, six characters will be accepted. For example, IN "Enter X,Y or Z", V{S} specifies a string variable of up to six characters to be input.

Output of Data (Numeric and String)

Numerical and string data can be output from the RIO board using several methods. The message command, MG, can output string and numerical data. Also, the RIO can be commanded to return the values of variables and arrays, as well as other information using the interrogation commands, such as V1=? and TZ.

Sending Messages

Messages may be sent using the message command, MG. This command sends specified text and numerical or string data from variables or arrays to the screen.

Text strings are specified in quotes and variable or array data is designated by the name of the variable or array. For example:

```
MG "The Final Value is", RESULT
```

In addition to variables, functions and commands, responses can be used in the message command. For example:

```
MG "The input is", @IN[1]
```

Formatting Messages

String variables can be formatted using the specifier, {Sn} where n is the number of characters, 1 thru 6. For example:

```
MG STR {S3}
```

This statement returns 3 characters of the string variable named STR.

Numeric data may be formatted using the {Fn.m} expression following the completed MG statement. {Fn.m} formats data in HEX instead of decimal. The actual numerical value will be formatted with n characters to the left of the decimal and m characters to the right of the decimal. Leading zeros will be used to display specified format.

For example:

```
MG "The Final Value is", RESULT {F5.2}
```

If the value of the variable RESULT is equal to 4.1, this statement returns the following:

```
The Final Value is 00004.10
```

If the value of the variable RESULT is equal to 999999.999, the above message statement returns the following:

```
The Final Value is 99999.99
```

The message command normally sends a carriage return and line feed following the statement. The carriage return and the line feed may be suppressed by sending {N} at the end of the statement. This is useful when a text string needs to surround a numeric value.

Example:

```
#A
FNAME="John"
LNAME="Smith"
MG "The name is ", FNAME{S3} {N}
MG " ", LNAME{S6}
EN
```

When #A is executed, the above example will appear on the screen as:

```
The name is John Smith
```

Using the MG Command to Configure Terminals

The MG command can be used to configure a terminal. Any ASCII character can be sent by using the format {^n} where n is any integer between 1 and 255.

Example:

```
MG {^07} {^255}
```

sends the ASCII characters represented by 7 and 255 to the bus.

Summary of Message Functions:

Function	Description
" "	Surrounds text string
{Fn.m}	Formats numeric values in decimal n digits to the right of the decimal point and m digits to the left
{\$n.m}	Formats numeric values in hexadecimal
{^n}	Sends ASCII character specified by integer n
{N}	Suppresses carriage return/line feed
{Sn}	Sends the first n characters of a string variable, where n is 1 thru 6.

{Zn.m}	Formats values like {Fn.m} except leading zeroes are removed
{En}	Outputs message to Ethernet handle n where n is A,B or C
{P1}	Outputs message to Serial port
{M}	Sends Email message (see MA, MD, MS commands)

Displaying Variables and Arrays

Variables and arrays may be sent to the screen using the format, variable= or array[x]=. For example, V1=, returns the value of V1.

Removing Leading Zeros from Response

The leading zeros on data returned as a response to interrogation commands or variables and arrays can be removed by the use of the command, LZ. The default value for LZ is 1, meaning that the leading zeroes do not get printed out unless LZ0 command is entered.

Example - Using the LZ command

LZ0	Disables the LZ function
MG@IN[0]	Print input status of bank 1
000000001.0000	Response from Interrogation Command (With Leading Zeros)
LZ1	Enables the LZ function
MG@IN[0]	Print input status of bank 1
1.0000	Response from Interrogation Command (Without Leading Zeros)

Formatting Variables and Array Elements

The Variable Format (VF) command is used to format variables and array elements. The VF command is specified by:

VF m.n

where m is the number of digits to the left of the decimal point (0 thru 10), and n is the number of digits to the right of the decimal point (0 thru 4).

A negative sign for m specifies hexadecimal format. The default format for VF is VF 10.4

Hex values are returned preceded by a \$ and in 2's complement.

:V1=10	Assign V1
:V1=	Return V1
0000000010.0000	Default format
:VF2.2	Change format
:V1=	Return V1
10.00	New format
:VF-2.2	Specify hex format
:V1=	Return V1
\$0A.00	Hex value
:VF1	Change format
:V1=	Return V1
9	Overflow

Local Formatting of Variables

VF command is a global format command that affects the format of all relevant returned values and variables. Variables may also be formatted locally. To format locally, use the command, {Fn.m} or {\$n.m} following the variable name and the '=' symbol. F specifies decimal and \$ specifies hexadecimal. n is the number of digits to the left of the decimal, and m is the number of digits to the right of the decimal. For example:

Examples:

:V1=10	Assign V1
:V1=	Return V1
0000000010.0000	Default Format
:V1={F4.2}	Specify local format
0010.00	New format
:V1={\$4.2}	Specify hex format
\$000A.00	Hex value
:V1="ALPHA"	Assign string "ALPHA" to V1
:V1={S4}	Specify string format first 4 characters
ALPH	

The local format is also used with the MG command (see page 70).

Programmable I/O

As described earlier, the RIO has 16 digital inputs, 16 digital outputs, 8 analog inputs and 8 analog outputs. The paragraphs below describe the commands that are used for I/O manipulation and interrogation.

Digital Outputs

The most common method of changing the state of digital outputs is by using the set bit 'SB' and clear bit 'CB' commands. The following table shows an example of the SB and CB commands.

<u>Instruction</u>	<u>Interpretation</u>
SB2	Sets bit 2
CB1	Clears bit 1

The Output Bit (OB) instruction is useful for setting or clearing outputs depending on the value of a variable, array, input or expression. Any non-zero value results in a set bit.

<u>Instruction</u>	<u>Interpretation</u>
OB1,POS	Set Output 1 if the variable POS is non-zero. Clear Output 1 if POS equals 0.
OB2,@IN [1]	Set Output 2 if Input 1 is high. If Input 1 is low, clear Output 2.
OB3,@IN [1]&@IN [2]	Set Output 3 only if Input 1 and Input 2 are high.
OB2,COUNT [1]	Set Output 2 if element 1 in array COUNT is non-zero.

The output port can be set by specifying the OP (Output Port) command. This instruction allows a single command to define the state of the entire output bank, where 2^0 is bit 0, 2^1 is bit 1 and so on. A 1 designates that the output is on.

For example:

<u>Instruction</u>	<u>Interpretation</u>
OP6	Sets bits 1 and 2 of bank 0 high. All other bits on bank 0 are 0. ($2^1 + 2^2 = 6$)
OP0,0	Clears all bits of bank 0 and 1
OP0,7	Sets output bits 0, 1 and 2 to one ($2^0 + 2^1 + 2^2$) on bank 1. Clears all bits on bank 0.

The state of the digital outputs can be accessed with the @OUT[n] where n is the output number (Ex: MG@OUT[1] displays the state of output number 1).

Digital Inputs

The digital inputs are accessed by using the @IN[n] function or the TI n command. The @IN[n] function returns the logic level of a specified input, n, where 'n' is the input bit number. The IQ command determines the active level of each input. The TI n command gives the input status of an entire bank, where 'n' is the bank number, 0 or 1. The AI command is a trip-point that pauses program execution until the specified combination of inputs is high or low.

Example – Using Inputs to control program flow

<u>Instruction</u>	<u>Instruction</u>
JP #A,@IN[1]=0	Jump to A if input 1 is low
MG@IN[2]	Display the state of input 2
AI 7&-6	Wait until input 7 is high and input 6 is low

Analog Inputs

Analog inputs are accessed with the @AN[n] function where n is the number assigned to the analog input channel. The returned value will be a voltage reading with 12 bit resolution (16bit optional on RIO-47120). The standard voltage range is 0 to +5VDC on the RIO-47100. The voltage input range is configurable on the RIO-47120 using the AQ command.

Note: When analog input values are accessed from the Data Record or from the Record Array function, the returned value will be an integer number that represents the analog voltage. For a RIO-47100, the equation used to determine the decimal equivalent of the analog voltage is as follows:

$$N = (((V - V_{lo}) * 4095) / (V_{hi} - V_{lo})) * 8$$

Where N is the integer equivalent of the analog voltage, V is the expected analog voltage, V_{lo} is the lowest voltage in the total range (0V for the standard analog input module) and V_{hi} is the highest voltage in the total range (5V for the standard module). The data range for N is 0-32760.

These integer values will also be returned when accessing the analog inputs by the API calls in C/C++ or Visual Basic.

The AQ command also configures the analog inputs to be either 8 single ended (default) or 4 differential inputs.

The AA command is a trippoint that halts program execution until the specified voltage on an analog input is reached. The third field of the AA command controls whether the trippoint will be satisfied when going higher or lower than the voltage. With a command such as AA 1,4.5,0 - if the specified voltage is exceeded prior to arrival at the AA command, the program will continue to execute without a pause. Analog inputs are useful for reading special sensors such as temperature, tension or pressure. The range of AA is dependant on the AQ setting. Here are some examples of using the Analog inputs:

Instruction

JP #C,@AN[1]>2
 MG@AN[2]
 AA 1,4,5,0
 AA 1,3,2,1

Instruction

Jump to A if analog input number 1 is greater than 2 volts
 Display the analog voltage reading on input 2
 Wait until the voltage on input 1 goes above 4.5V
 Wait until the voltage on input 1 goes below 3.2V

Analog Outputs

Analog output voltage is set with the AO command. The AO command has the format AO m,n where m is the output pin and n is the voltage assigned to it. The analog output voltage is accessed with the @AO[n] function where n is the analog output channel. Analog output modules come with a resolution of 12 bits (16bit optional). The standard voltage range is 0 to +5VDC for the RIO-47100. The Analog Output voltage range is configurable using the DQ command when using the RIO-47120. Use the ID command to see the model number of the RIO.

Note: When analog output values are accessed from the Data Record or from the Record Array function, the returned value will be an integer number that represents the analog voltage. For a RIO-47100, the equation used to determine the decimal equivalent of the analog voltage is as follows:

$$N = ((V - V_{lo}) * 4095) / (V_{hi} - V_{lo})$$

Where N is the integer equivalent of the analog voltage, V is the expected analog voltage, V_{lo} is the lowest voltage in the total range (0V for the standard analog input module) and V_{hi} is the highest voltage in the total range (5V for the standard module).

These integer values will also be returned when accessing the analog inputs by the API calls in C/C++ or Visual Basic.

The AO command can also be used to set the analog voltage on ModBus devices over Ethernet

Instruction

AO 7,1.5
 MG@AO[2]

Instruction

Set the output voltage on output 7 to 1.5V
 Display the analog voltage reading on output 2

Real Time Clock

The RIO-471x2 firmware revision D and above is equipped with a real time clock feature. The real time clock provides true time in seconds, minutes and hours. The RT command provides a method to set the time and operands to return the current time. The default real time clock does not persist through a power cycle and must be set whenever power is restored.

The RIO-471x2 can be ordered with a clock upgrade (-RTC) including a higher precision clock than the default, and a battery backup for the time hardware. All hardware is within the standard sheet metal footprint. The -RTC clock will continue to run when power is removed from the RIO. The -RTC option also provides a calendar function including year, month of year, day of month, and day of week. This feature can be set and queried through the RY command.

Both versions of the RIO-471x2 real time clock can be set to a TIME protocol (RFC 868) server. Using IH, the RIO can connect to a TIME server over TCP on port 37 and receive the 32bit response. The firmware will then set the time and calendar (if applicable) to the TIME server value. The command RO is used to set the GMT time zone offset for localization of the current time. The TIME protocol synchronization is designed to connect to a server on the local network. Contact Galil if a local server is not available (e.g. an Internet Gateway is required to contact NIST).

See the -RTC section in the Appendix for further details and specifications for the real time clock.

Appendix

Electrical Specifications

Input/Output

Digital I/O	See Chapter 4.
DAC Output Current	4mA max output per channel
47120: +/-12V out	10mA max output

Power Requirements

18-36 VDC	Typical: RIO-4710x – 1.4W
	RIO-4712x – 2.6W
	RIO-47200 – 2.1W
	Max: 4 Watts

Performance Specifications

RIO-47xx0

Variable Range:	+/-2 billion
Variable Resolution:	$1 \cdot 10^{-4}$
Variable Size	126 variables
Array Size:	400 elements, 6 array names
Max Program Labels:	62
Program Size:	200 lines x 40 characters
Maximum Number of Burn Cycles:	10,000 (BP, BN, BV combined)

RIO-47xx2

Variable Range:	+/-2 billion
Variable Resolution:	$1 \cdot 10^{-4}$
Variable Size	256 variables
Array Size:	1000 elements, 6 array names
Max Program Labels:	126
Program Size:	400 lines x 40 characters
Maximum Number of Burn Cycles:	10,000 (BP, BN, BV combined)

Certifications

The RIO-471xx is certified for the following when the product or package is marked.

ETL



CE

http://www.galilmc.com/products/ce_documents/rio47000_ce_dc.pdf

ROHS

ROHS Compliant

Standard Options

The RIO-47xxx can be ordered in many different configurations and with different options. This section provides information regarding the different options available on the RIO-47xxx. For more information on pricing and how to order an RIO with these options, see our RIO-47xxx part number generator on our website.

<http://www.galilmc.com/products/rio-47xxx-part-number.php>

-DIN

If ordered with the –DIN option the RIO has a DIN rail mount attached to the case. This option is valid for all RIO-471xx controllers. It is not valid for the RIO-472xx family as the RIO-472xx comes in a DIN rail mount by default.

Part number ordering example: RIO-47100-DIN

-NO DIN

This option is only valid with the RIO-472xx. This option removes the din rail clips. The unit will still be in a plastic tray.

Part number ordering example: RIO-47200-NO DIN

-422

This option allows the RIO to communicate via RS-422 instead of RS-232.

Pin Number	Description	Pin Number	Description
1	RTS-	6	RTS+
2	TXD-	7	TXD+
3	RXD-	8	RXD+
4	CTS-	9	CTS+
5	GND		

Part number ordering example: RIO-47100-422

-RTC

The RIO-471x2 provides a real time clock feature. –RTC provides an extended feature set.

Real time clock	RIO-471x2	RIO-471x2-RTC
RT providing Hours, Minutes, Seconds	Yes	Yes
RY providing Year, Month of year, Day of month, Day of week	No	Yes
Settable via TIME protocol server (IH and RO commands)	Yes	Yes
Clock persists through RIO power loss	No	Yes
No-power clock battery life	N/A	More than 1 week*

*Time till failure pending at the time of publication

Part number ordering example: RIO-47122-RTC

-08-15 SOURCE (2LSRC) option

If a RIO-471xx is ordered with the -08-15 SOURCE option then outputs 8-15 are configured to source current. They will be capable of 5-24VDC with 25mA of current in a sourcing configuration.

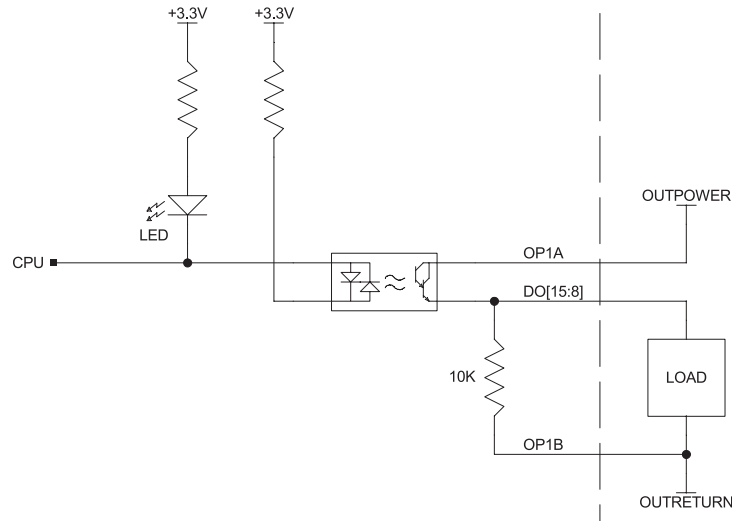

Figure 8: Low Power Sourcing Outputs

OP1A should be connected to the positive side of 5-24VDC external power supply.

OP1B should be connected to Ground on the external power supply.

OP1A and OP1B are the Output Power for Bank 1. The output can source up to 25mA of current. The device should be connected between the digital output DO[15:8] and the return side of the power supply (OP1B). When current is **not** flowing through the optocoupler (CB), the 10k resistor pulls-down the output pin to OP1B. When current **is** flowing through the optocoupler (SB), the digital output switches to the voltage supplied by OP1A and is able to source 25mA of current. The **bold** connections in the schematic above are external connections.

Part number ordering example: RIO-47100-(1HSRC,2LSRC)

-0-7 or -8-15 SINK/SOURCE

These four options are only available on the RIO-472xx. By default the RIO-472xx has all 16 high power outputs. These options allow either of the two banks of 8 outputs to be configured for low power sinking or low power sourcing. For example, if output 0-7 need to be configured for low power sourcing and outputs 8-15 need to be configured for high power sourcing the option would be (1LSRC, 2HRSC). The circuits for low power sourcing and sinking will be the same as the circuits for the low power outputs previously defined in Chapter 4.

Part number ordering example: RIO-47200-(1LSNK,2LSRC)

-Outputs 0-7 low power sinking, Outputs 8-15 low power sourcing

-QUAD and -SSI

All RIO-47122 Encoder Options will utilize Digital Inputs 12,13,14 and 15 and Digital Outputs 12,13,14 and 15. These digital inputs and outputs will not be available as standard digital I/O when the -QUAD or -SSI option is ordered with the RIO-47122.

The QE command is used to read the encoder register, the WE command sets the current position of the encoder (-QUAD only) and the SE command configures the encoder when the -SSI option is ordered. The

register that is read using the QE command is updated by the RIO every 25ms. See the QE, WE and SE commands in the RIO command reference for more information.

Electrical Specifications

Power:	The encoders must be powered by an external power supply. The RIO does not supply power to the encoder.
Input buffers:	AM23LV32
Output buffers (SSI Clock):	AMP26LV31
-QUAD maximum frequency:	8 MHz ¹

¹ Hardware update rate. Register read by the QE command is updated at a rate of 40Hz.

-QUAD Pinout

Encoder Signal	Label (Connector.Pin)
Channel 0 A+	DO14 (J4.24)
Channel 0 A-	DO12 (J4.39)
Channel 0 B+	DO15 (J4.38)
Channel 0 B-	DO13 (J4.9)
Channel 1 A+	DI14 (J4.31)
Channel 1 A-	DI12 (J4.2)
Channel 1 B+	DI15 (J4.1)
Channel 1 B-	DI13(J4.17)
Ground	N/C (J4.41)

-SSI Pinout

Encoder Signal	Label (Connector.Pin)
Channel 0 Clock+	DO14 (J4.24)
Channel 0 Clock-	DO12 (J4.39)
Channel 0 Data+	DO15 (J4.38)
Channel 0 Data-	DO13 (J4.9)
Channel 1 Clock+	DI14 (J4.31)
Channel 1 Clock -	DI12 (J4.2)
Channel 1 Data+	DI15 (J4.1)
Channel 1 Data-	DI13(J4.17)
Ground	N/C (J4.41)

Part number ordering example: RIO-47122-QUAD

-PWM

Using the DY, PM and FQ commands, digital outputs 14 and 15 can be configured as PWM outputs with a frequency range of 10-20,000 Hz. This is only available on firmware Revs D and above. By default the maximum frequency output will be limited by the bandwidth of the digital outputs. With the -PWM option the opto-isolated outputs are bypassed and buffered outputs are supplied for DO 14:15.

Electrical Specifications for DO14:15 with –PWM option

V_O Output Voltage Range	0V to 3.3V
I_O Current output - Sink/Source	5 mA (Max)

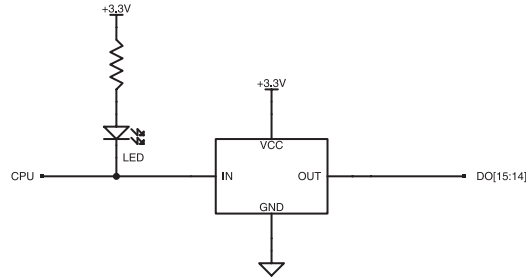

Figure 9: -PWM option

For the standard low power digital outputs found on the RIO-471xx the bandwidth is 50 Hz.

Part number ordering example: RIO-47102-PWM

-HS

This option changes digital input 3 (DI3) to a high speed digital input. It is available on the RIO-47xxx as a standard option. With this option, the input becomes a TTL level input that is differential with respect to digital input 2 (DI2 is not available as an input with the –HS option). The maximum frequency of pulses that can be captured is increased to 3Mhz. If higher values are required, please consult factory.

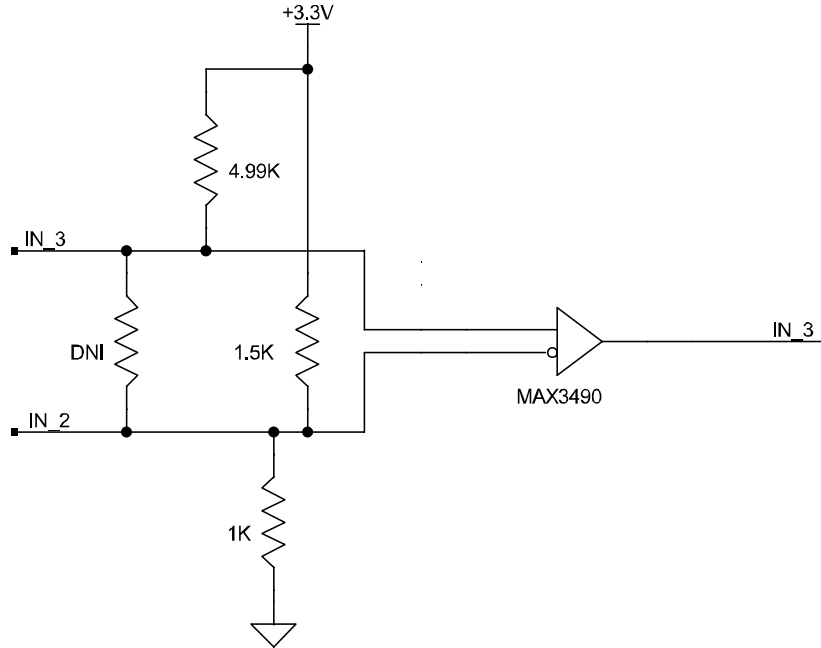

Figure 10: -HS Option

Part number ordering example: RIO-47100-HS

-16Bit

The -16 option specifies 16 bit resolution on the analog inputs and outputs. This option is valid on the RIO-4712x and RIO-472xx only.

Part number ordering example: RIO-47120-16bit

AI_10v12Bit

This option changes the analog inputs on the RIO-472xx to accept +/-10V analog signals with 12 bit resolution. The range of the analog inputs can be changed with the AQ command, similar to the RIO-4712x.

Part number ordering example: RIO-47200-(AI_10v12bit)

AI_10v16Bit

This option changes the analog inputs on the RIO-472xx to accept +/-10V analog signals with 16 bit resolution. The range of the analog inputs can be changed with the AQ command, similar to the RIO-4712x.

Part number ordering example: RIO-47200-(AI_10v16bit)

-(4-20mA)

This option installs resistors in parallel with each analog input. On RIO's with 0-5V analog input ranges the resistor is 1000 ohms and on RIO's with +/-10V analog input ranges the resistor value is 475 ohms (1%).

An RIO with +/-10V analog inputs should be configured for 0-10V range (AQ n, 4). With this setting, the range for 4-20mA will be 1.9V-9.5V. The equation for calculating the current is:

$$I_{mA} = \frac{V}{2.105}$$

Where I_{mA} = current in mA

V = Voltage reading from RIO

Part number ordering example: RIO-47120-(4-20mA)

AO Option (SCB-48608)

The RIO-47200 by default does not have analog outputs however analog outputs can be added using the AO option. When analog outputs are added, a new screw terminal board is added called the SCB-48608 and is attached to the RIO-47200 at the factory (cannot be installed in the field). This board supplies 8 analog outputs to the RIO-47200.

The option can be ordered with +/-10V configurable analog outputs in either 12 or 16 bits – same as RIO-4712x, or with 0-5V analog outputs 12 bit resolution – same as RIO-4710x. See the DQ command for specifics on the +/-10V configurable options.

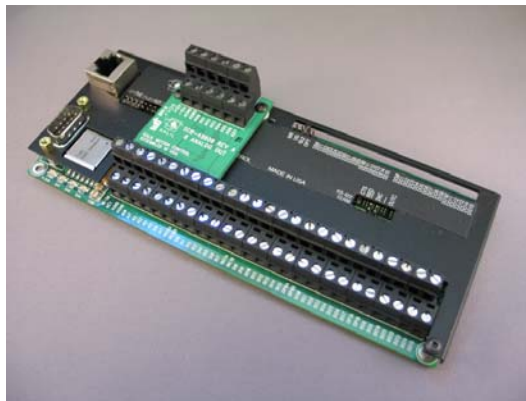

Figure 11: SCB-48608

The +/-12V terminals will provide +/-12V output only when the outputs are ordered as +/-10V configurable outputs. Maximum current draw is 10mA each.

When then 0-5V analog outputs are ordered the +/-12V terminals will be No Connects.

Part number ordering example: RIO-47200-(8AO_10v12bit)

Qty 8 +/-10V configurable analog outputs with 12 bit resolution.

Connectors for RIO-47xxx

44 pin D-Sub Connector – RIO-471xx

Pin	Label	Description	Pin	Label	Description	Pin	Label	Description
1	DI15	Digital Input 15	16		No Connect / INC1B ¹	31	DI14	Digital Input 14
2	DI12	Digital Input 12	17	DI13	Digital Input 13	32	DI11	Digital Input 11
3	DI9	Digital Input 9	18	DI10	Digital Input 10	33	DI8	Digital Input 8
4	N/C	No Connect	19	INC1	Input Common DI[8-15]	34	N/C	No Connect / INC0B ¹
5	DI6	Digital Input 6	20	DI7	Digital Input 7	35	DI5	Digital Input 5
6	DI3 ⁴	Digital Input 3	21	DI4	Digital Input 4	36	DI2 ⁴	Digital Input 2
7	DI0	Digital Input 0	22	DI1	Digital Input 1	37	INC0	Input Common DI[0-7]
8	OP1B ²	+5-24V Output Power Supply for DO[8-15] ²	23	N/C	No Connect	38	DO15 ⁵	Digital Output 15
9	DO13	Digital Output 13	24	DO14 ⁵	Digital Output 14	39	DO12	Digital Output 12
10	DO10	Digital Output 10	25	DO11	Digital Output 11	40	DO9	Digital Output 9
11	OP1A ³	Output Power Ground for DO[8-15] ³	26	DO8	Digital Output 8	41	N/C	No Connect
12	DO7	Digital Output 7	27	OP0B	Output Power GROUND for DO[0-7]	42	DO6	Digital Output 6
13	DO4	Digital Output 4	28	DO5	Digital Output 5	43	DO3	Digital Output 3
14	DO1	Digital Output 1	29	DO2	Digital Output 2	44	DO0	Digital Output 0
15	OP0A	+12-24V Output Power Supply for DO[0-7]	30	OP0A	+12-24V Output Power Supply for DO[0-7]			

¹Note: INC0B and INC1B are only valid when INC jumpers are used.

² When ordered with -08-15 SOURCE this pin will actually be Output Power Ground for DO[8-15]

³ When ordered with -08-15 SOURCE this pin will actually be +5-24V Output Power Supply for DO[8-15]

⁴ When ordered with -HS option DI3 is high-speed input+ and DI2 is high-speed input- (DI2 is lost)

⁵ PWM outputs. See -PWM option in Appendix and Chapter 4.

26 pin D-Sub Connector – RIO-471xx

Pin	Label	Description	Pin	Label	Description	Pin	Label	Description
1	N/C	No Connect	10	N/C	No Connect	19	N/C	No Connect
2	N/C +12V	47100: No Connect 47120: +12V out (10mA)	11	N/C	No Connect	20	N/C -12V	47100: No Connect 47120: -12V out (10mA)
3	AI7	Analog Input 7	12	GND	Ground	21	AI6	Analog Input 6
4	AI4	Analog Input 4	13	AI5	Analog Input 5	22	AI3	Analog Input 3
5	AI1	Analog Input 1	14	AI2	Analog Input 2	23	AI0	Analog Input 0
6	GND	Ground	15	GND	Ground	24	AO7	Analog Output 7
7	AO5	Analog Output 5	16	AO6	Analog Output 6	25	AO4	Analog Output 4
8	AO2	Analog Output 2	17	AO3	Analog Output 3	26	AO1	Analog Output 1
9	GND	Ground	18	AO0	Analog Output 0			

Screw Terminals – RIO-472xx

Label	Description	Label	Description
18-36	18-36VDC logic power input	DI10	Digital Input 10
RET	Return side of logic power input	DI11	Digital Input 11
AGND	Analog Ground	DI12	Digital Input 12
AGND	Analog Ground	DI13	Digital Input 13
AI0	Analog Input 0	DI14	Digital Input 14
AI1	Analog Input 1	DI15	Digital Input 15
AI2	Analog Input 2	OP0A	+12-24V Output Power Supply for DO[0-7]
AI3	Analog Input 3	OP0B	Output Power GROUND for DO[0-7]
AI4	Analog Input 4	DO0	Digital Output 0
AI5	Analog Input 5	DO1	Digital Output 1
AI6	Analog Input 6	DO2	Digital Output 2
AI7	Analog Input 7	DO3	Digital Output 3
INC0A	Input common DI[0-7]	DO4	Digital Output 4
INC0B	No connect for standard configuration	DO5	Digital Output 5
DI0	Digital Input 0	DO6	Digital Output 6
DI1	Digital Input 1	DO7	Digital Output 7
DI2	Digital Input 2 ²	OP1A	+12-24V Output Power Supply for DO[8-15]
DI3	Digital Input 3 ²	OP1B	Output Power GROUND for DO[8-15]
DI4	Digital Input 4	DO8	Digital Output 8
DI5	Digital Input 5	DO9	Digital Output 9
DI6	Digital Input 6	DO10	Digital Output 10
DI7	Digital Input 7	DO11	Digital Output 11
INC1A	Input common DI[8-15]	DO12	Digital Output 12
INC1B	No connect for standard configuration	DO13	Digital Output 13
DI8	Digital Input 8	DO14 ¹	Digital Output 14
DI9	Digital Input 9	DO15 ¹	Digital Output 15

¹ PWM outputs. See –PWM option in Appendix and Chapter 4.

² When ordered with –HS option DI3 is high-speed input+ and DI2 is high-speed input- (DI2 is lost)

J2 RS-232 Port: DB-9 Pin Male

Standard connector and cable, 9Pin.

Pin	Signal
1	No Connect
2	TXD
3	RXD
4	No Connect
5	Ground
6	No Connect
7	CTS
8	RTS
9	No Connect

Note: A straight-thru serial cable should be used to connect the RIO to a standard PC serial port (pin1 to pin1, pin2 to pin 2, etc...)

J1 Ethernet Port: 10/100 Base-T (RJ-45)

Pin	Signal
1	TXP
2	TXN
3	RXP
4	Reserved
5	Reserved
6	RXN
7	Reserved
8	Reserved

J5 Power: 2 pin Molex

Voltage range is 18-36VDC for RIO-471xxx. Not used with RIO-47200.

This connector is not used when powering the RIO via POE.

The part number listed below is the connector that is found on the controller. For more information see the Molex website. <http://www.molex.com/>

Pin	Signal
1	GND (Ground)
2	18-36VDC



Molex Part Number	Pin Part Number (x2)	Type
39-31-0020	44476-3112	2 Position

Jumper Description for RIO

Jumper	Label	Function (If jumpered)
JP5	MRST	Master Reset enable. Returns RIO to factory default settings and erases non-volatile memory. Requires power-on or RESET to be activated.
	UPGD	Used to upgrade controller firmware when resident firmware is corrupt.
	19.2	Set baud Rate to 19.2k (default without jumper is 115k)
	OPT	10BaseT Ethernet Communication

Jumper	Label	Function (If jumpered)
JP6	AUX (4 jumpers)	Power for board comes from 2pin Molex Connector (18-36V DC)
JP7	PoE (4 jumpers)	Power for board comes from Power over Ethernet (No power cable is necessary – Ethernet cable with PoE Switch is required)

Jumper	Label	Function (If jumpered)
JP102	INC	Connects INC0 & INC1 to +5V and INC0B & INC1B to GND
JP102	OUTC	Connects OP1A to GND and OP1B to +5V

RIO Dimensions

RIO-471xx

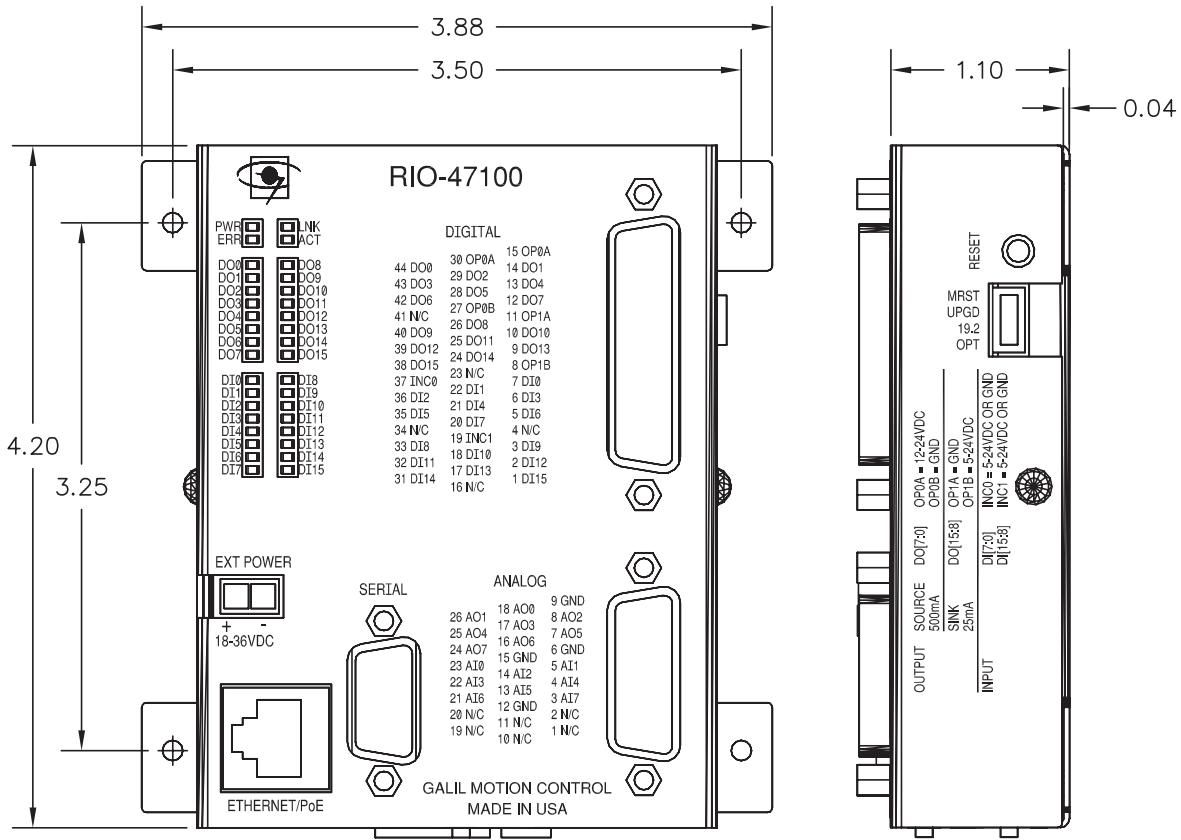

Units in centimeters

RIO-472xx

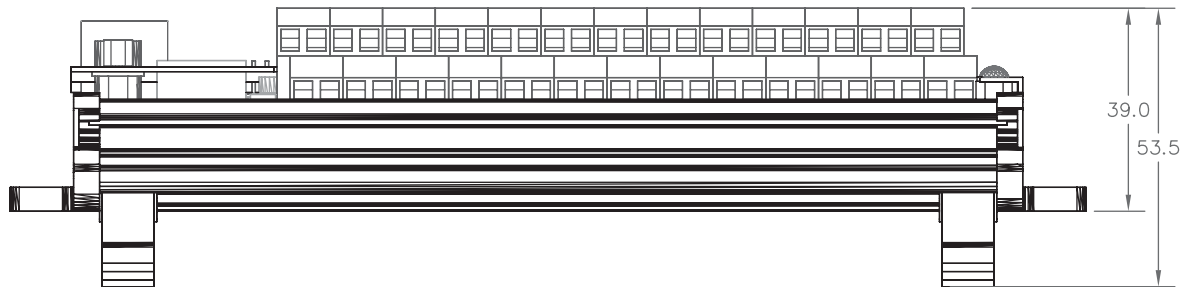
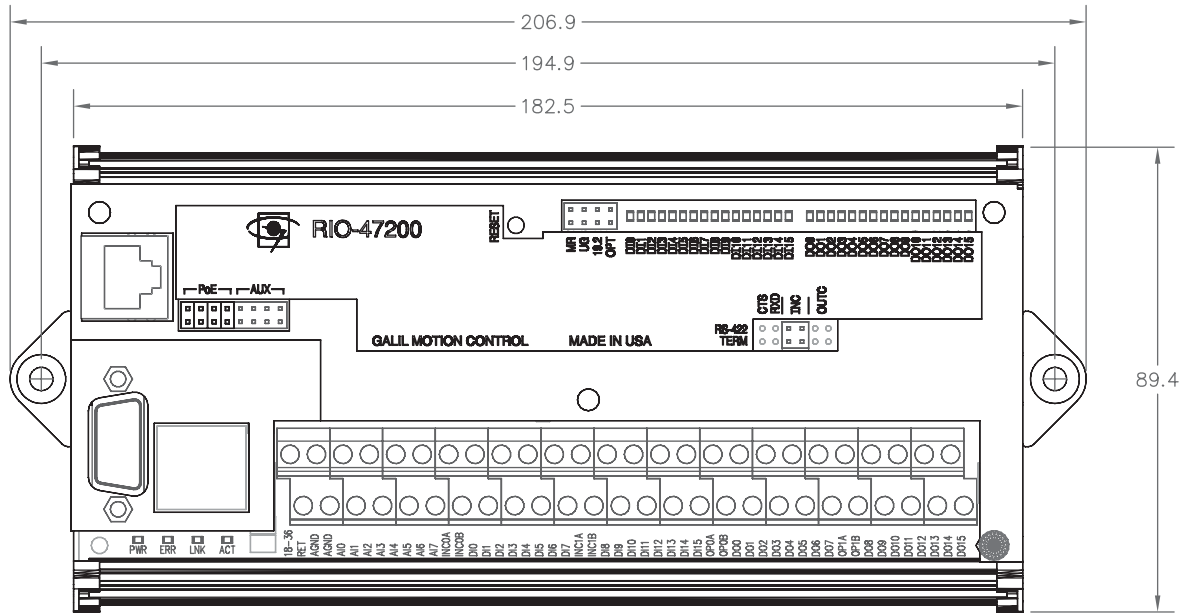

Units in millimeters

Accessories and Options

Product	Description
RIO-47100	Remote I/O controller with 0-5V analog I/O; 12bit
RIO-47120	Remote I/O controller with $\pm 10V$ analog I/O; 12bit
RIO-47120-16	Remote I/O controller with $\pm 10V$ analog I/O; 16bit
ICS-48026-M	26-pin D high-density male to screw terminals. Use 1 for each RIO-471x0 to break out analog signals
ICS-48044-M	44-pin D high-density male to screw terminals. Use 1 for each RIO-471x0 to break out analog signals
SCB-48206	26-pin D high-density Signal Conditioning Board interfaces to up to six RTDs (Resistive Temperature Device)
SCB-48306	26-pin D high-density Signal Conditioning Board provides interface for up to six thermocouples
CABLE-44M-1M	44-pin D high-density male cable to discrete wires. Use 1 for each RIO-471x0 to break out analog signals -1M = 1 meter length. Order -2M for 2 meter length
CABLE-26M-1M	26-pin D high-density male cable to discrete wires. Use 1 for each RIO-471x0 to break out analog signals

List of Other Publications

"Step by Step Design of Motion Control Systems"

by Dr. Jacob Tal

"Motion Control Applications"

by Dr. Jacob Tal

"Motion Control by Microprocessors"

by Dr. Jacob Tal

Contacting Us

Galil Motion Control

270 Technology Way
Rocklin, CA 95765

Phone: 916-626-0101

Fax: 916-626-0102

E-Mail Address: support@galilmc.com

URL: www.galilmc.com

Training Seminars

Galil, a leader in motion control with over 500,000 controllers working worldwide, has a proud reputation for anticipating and setting the trends in motion control. Galil understands your need to keep abreast with these trends in order to remain resourceful and competitive. Through a series of seminars and workshops held over the past 15 years, Galil has actively shared their market insights in a no-nonsense way for a world of engineers on the move. In fact, over 10,000 engineers have attended Galil seminars. The tradition continues with three different seminar, each designed for your particular skill set--from beginner to the most advanced.

MOTION CONTROL MADE EASY

WHO SHOULD ATTEND

Those who need a basic introduction or refresher on how to successfully implement servo motion control systems.

TIME: 4 hours (8:30 am-12:30 pm)

ADVANCED MOTION CONTROL

WHO SHOULD ATTEND

Those who consider themselves a "servo specialist" and require an in-depth knowledge of motion control systems to ensure outstanding controller performance. Also, prior completion of "Motion Control Made Easy" or equivalent is required. Analysis and design tools as well as several design examples will be provided.

TIME: 8 hours (8:00 am-5:00 pm)

PRODUCT WORKSHOP

WHO SHOULD ATTEND

Current users of Galil motion controllers. Conducted at Galil's headquarters in Rocklin, CA, students will gain detailed understanding about connecting systems elements, system tuning and motion programming. This is a "hands-on" seminar and students can test their application on actual hardware and review it with Galil specialists.

TIME: Two days (8:30 am-5:00 pm)

WARRANTY

All products manufactured by Galil Motion Control are warranted against defects in materials and workmanship. The warranty period for all products is 18 months except for motors and power supplies which have a 1 year warranty.

In the event of any defects in materials or workmanship, Galil Motion Control will, at its sole option, repair or replace the defective product covered by this warranty without charge. To obtain warranty service, the defective product must be returned within 30 days of the expiration of the applicable warranty period to Galil Motion Control, properly packaged and with transportation and insurance prepaid. We will reship at our expense only to destinations in the United States.

Any defect in materials or workmanship determined by Galil Motion Control to be attributable to customer alteration, modification, negligence or misuse is not covered by this warranty.

EXCEPT AS SET FORTH ABOVE, GALIL MOTION CONTROL WILL MAKE NO WARRANTIES EITHER EXPRESSED OR IMPLIED, WITH RESPECT TO SUCH PRODUCTS, AND SHALL NOT BE LIABLE OR RESPONSIBLE FOR ANY INCIDENTAL OR CONSEQUENTIAL DAMAGES.

COPYRIGHT (2008)

The software code contained in this Galil product is protected by copyright and must not be reproduced or disassembled in any form without prior written consent of Galil Motion Control, Inc.

A1 – SCB-48206

Description

The SCB-48206 Signal Conditioning Board interfaces to up to six 3-wire RTD's (Resistive Temperature Device). The SCB-48206 is designed to work with the RIO-4712x.

The SCB-48206 plugs directly into the Analog 26-pin high-density D-sub connector and will use Analog Inputs 0-5 on the RIO for the 6 RTD inputs. (RTD[0:5] = AI[0:5]).¹ It is oriented vertically from the RIO connector as shown in Figure 12. Other mounting options are available upon request.



Figure 12: RIO-47122 with SCB-48206

¹ Analog inputs 0-5 will not be available for general use analog inputs when the SCB-48026 is connected to the RIO.

Specifications

Number of Inputs	6 RTD inputs
RTD input – Analog Input Map	RTD[0:5] = AI[0:5]
Output Range	0-5V
Excitation Current	1 mA
Input Range	18 – 230 Ω ¹
Temperature Range (100 Ω RTD)	-200 to 350 deg C ¹

1 If greater than 230 Ω (350 deg C) is required, contact Galil.

Wiring

The SBC-48206 has qty 6, 3-wire RTD inputs. The RTD is wired directly to the screw terminals as indicated in Figure 13 below.

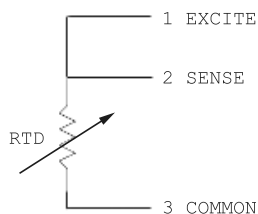

Figure 13: RTD wiring to SBC-48206

Operation

The SBC-48206 will send a 0-5V analog voltage to the RIO that is related to the resistance of the RTD. When using the SBC-48026, the analog inputs should be set to 0-5V inputs for the 6 RTD inputs. This is done with the AQ command with a setting of 3 (AQ n,3 – where n = 0-5).

The calculation for the resistance of the RTD from the analog voltage is given from the following equation.

$$R = (1000 * V) / 21$$

Where R = Resistance of RTD
V = Analog Read from RIO

There are 2 methods for calculating the temperature once the resistance of the RTD has been calculated.

Note: The following calculations assume an RTD with $R_0 = 100 \Omega$ and $\alpha = 0.00385$ (Platinum RTD).

Method 1

This method strictly uses the RTD coefficient and assumes a proportional relationship between impedance and temperature. The equation for this is given in the following equation.

$$T_c = (R - R_0) / (\alpha * 100)$$

Where T_c = Temperature in deg C
 R_0 = 100 Ω
 α = 0.00385

Below is an example program for using Method 1 that could run on the RIO-4712x.

```
#MAIN
REM set Analog inputs 0-5 to 0-5V inputs
AQ 0,3
AQ 1,3
AQ 2,3
AQ 3,3
AQ 4,3
AQ 5,3
AT0;'set initial time reference
#Calc
REM calculate resistance of RTD
r0 = (1000*@AN[0])/21
r1 = (1000*@AN[1])/21
r2 = (1000*@AN[2])/21
r3 = (1000*@AN[3])/21
r4 = (1000*@AN[4])/21
r5 = (1000*@AN[5])/21
REM calculate deg C
Tc0 = (r0-100)/0.385
Tc1 = (r1-100)/0.385
Tc2 = (r2-100)/0.385
Tc3 = (r3-100)/0.385
Tc4 = (r4-100)/0.385
Tc5 = (r5-100)/0.385
REM calculate deg F (not required)
Tf0 = ((9*Tc0)/5)+32
Tf1 = ((9*Tc1)/5)+32
Tf2 = ((9*Tc2)/5)+32
Tf3 = ((9*Tc3)/5)+32
Tf4 = ((9*Tc4)/5)+32
Tf5 = ((9*Tc5)/5)+32
AT-100;'wait 100 ms from last time reference
JP#Calc
```

This method provides a relatively accurate temperature reading with a simple and straight-forward calculation. A limitation with this method is that it uses an idealized relationship between the impedance of an RTD and the temperature of the RTD. In reality, the relationship between impedance and temperature is not linear, so if higher precision is required from the temperature reading, the following Method should be used.

Method 2

This method uses the following equations to calculate the temperature of the RTD. These equations more accurately describe the relationship between temperature and impedance of the RTD than Method 1.

$$\begin{aligned} \text{For } T_c > 0 \text{ deg C (R(t)>100)} & \quad R(t) = R_0 (1 + A * T_c + B * T_c^2) \\ \text{For } T_c < 0 \text{ deg C (R(t)<100)} & \quad R(t) = R_0 (1 + A * T_c + B * T_c^2 + C (T_c - 100) * T_c^3) \end{aligned}$$

Where $R(t)$ = Resistance of RTD
 $R_0 = 100 \Omega$
 $A = 3.9083 * 10^{-3} * \text{deg C}^{-1}$
 $B = -5.775 * 10^{-7} * \text{deg C}^{-2}$
 $C = -4.183 * 10^{-12} * \text{deg C}^{-4}$

Below is an example program for using Method 2 that could run on the RIO-4712x.

Note: The coefficients have been modified to avoid round off errors in the calculations in the temperature readings.

```
#MAIN
REM set Analog inputs 0-5 to 0-5V inputs
AQ 0,3
AQ 1,3
AQ 2,3
AQ 3,3
AQ 4,3
AQ 5,3
AT0;'set initial time reference
#Calc
REM calculate resistance of RTD
r0 = (1000*@AN[0])/21
r1 = (1000*@AN[1])/21
r2 = (1000*@AN[2])/21
r3 = (1000*@AN[3])/21
r4 = (1000*@AN[4])/21
r5 = (1000*@AN[5])/21
REM calculate deg C
r=r0;JS#Celcius;Tc0 = Tc
r=r1;JS#Celcius;Tc1 = Tc
r=r2;JS#Celcius;Tc2 = Tc
r=r3;JS#Celcius;Tc3 = Tc
r=r4;JS#Celcius;Tc4 = Tc
r=r5;JS#Celcius;Tc5 = Tc
AT-100;'wait 100 ms from last time ref
JP#Calc

#Celcius
sqrt=@SQR[992137.445376*(761.2471-r)]
Tc = (-25613.43488+sqrt)/(-7.569408)
REM adjust for Tc < 0 deg C
IF (Tc < 0)
Ta=-(((Tc-100)*Tc*Tc)/239062873.536)*Tc
Ta = Ta * 0.2311
Tc = Tc - Ta
ENDIF
EN
```

A2 – SCB-48306/48316

Description

The SCB-48306 and the SCB-48316 Signal Conditioning Board interface to up to 6 thermocouples. The SCB-483x6 boards are designed to work with the RIO-4712x. The SCB-48316 provides thermocouple terminal connectors for the 6 thermocouple inputs, the SCB-48306 provides screw terminals inputs for the 6 thermocouple inputs. Both SCB boards provide screw terminal connections for Analog inputs 6 and 7 (AI6:7), all 8 analog outputs (AO0:7) and two GND terminals.

The SCB-48306 can plug directly into the Analog 26-pin high-density D-sub connector and will use Analog inputs 0-5 on the RIO for the 6 thermocouple inputs. (TC[0:5] = AI[0:5]).¹ It is oriented vertically from the RIO connector as shown in Figure 14. Other mounting options are available upon request.

By default the SCB-483x6 will be setup for type K thermocouple inputs. Types E, J and T are also available. The thermocouples interfacing to the SCB-483x6 must have an Ungrounded or Exposed Junction (aka Floating Junction); contact Galil if Grounded Junction thermocouples are required.



Figure 14: SCB-48316

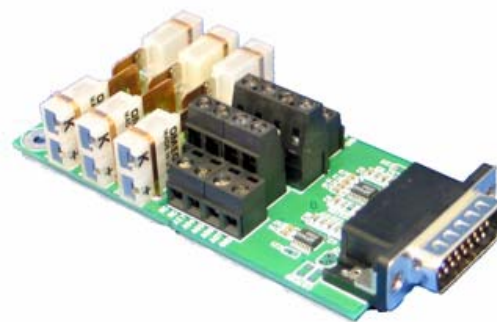

Figure 15: SCB-48306

¹ Analog inputs 0-5 will not be available for general use analog inputs when the SCB-483x6 is connected to the RIO.

Specifications

Number of Inputs	6 Thermocouple Inputs
Thermocouple input – Analog Input Map	TC[0:5] = AI[0:5]
Range ¹	Type K (default) 0 – 345 deg C Type E 0 – 230 deg C Type J 0 – 270 deg C Type T 0 – 345 deg C
Voltage Constant ²	Type K (default) 10.15 mV/deg C Type E 15.225 mV/deg C Type J 12.925 mV/deg C Type T 10.15 mV/deg C

- 1 Contact Galil if required temperatures are outside of listed ranges.
- 2 Voltage Constant will change if Range is modified

Wiring

The SCB-483x6 has qty 6 thermocouple inputs. The thermocouples interfacing to the SCB-483x6 must have an Ungrounded or Exposed Junction; contact Galil if Grounded Junction (Figure 17) thermocouples are required. The wiring of the thermocouple to the SCB-483x6 is shown in Figure 16 below.

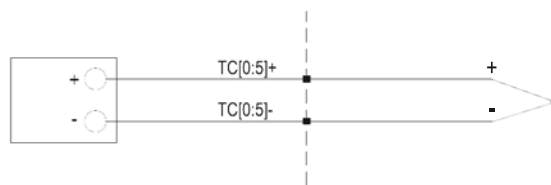

Figure 16: Thermocouple Wiring to SCB-483x6

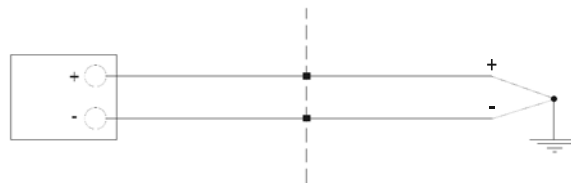

Figure 17: Grounded Thermocouple Input - Not supported with SCB-483x6

Operation

The SCB-483x6 will send an analog voltage to the RIO-4712x that is proportional to the temperature of the junction by the Voltage constant defined in the Specifications section. When using the SCB-483x6, the analog inputs should be set to 0-5V inputs for the thermocouple inputs. This is done with the AQ command with a setting of 3 (AQ n,3 – where n=0-5 for TC[0:5]).

The temperature can be determined by using the Voltage constants given in the Specifications section. The equation for calculating Temperature in deg C is:

$$\text{Temperature (deg C)} = (\text{@AN}[0:5] * 1000) / \text{Voltage Constant}$$

Where	@AN[0:5]	Analog input readings for TC[0:5]
	Voltage Constant	Voltage constant for SCB-483x6 and thermocouple type is defined in the Specifications section

The below code uses analog inputs 0-5 and stores the temperature into array Tc[0:5] – written for type K thermocouples.

```
#MAIN
REM Analog inputs 0-5 to 0-5V inputs
AQ 0,3
AQ 1,3
AQ 2,3
AQ 3,3
AQ 4,3
AQ 5,3
DM Tc[6]
voltK=10.15;'mV/deg C - type K
AT0;'set initial time reference
#Calc
n=0
#CalcH
Tc[n]=(@AN[n]*1000)/voltK
n=n+1
JP#CalcH,n<6
AT-100;'wait 100ms from last time ref
JP#Calc
```