

## TROUBLESHOOTING

### TROUBLESHOOTING GUIDE

Issue	Potential Cause	Potential Solution
• The air is not moving in the direction that I want it to.	• Airflow direction switches are not in the correct position.	✓ Adjust the airflow direction switches to intake, exhaust, or air exchange.
• Fan will not operate even though I am turning on the fan with the speed control button.	• Fan is not plugged in. • The fan is plugged in and is set to the Off position. • Preset temperature on the fan is set too high.	✓ Plug the cord into a 120V AC outlet. ✓ Turn the fan on using the speed button. Refer to Manual or Automatic Operating Instructions. ✓ Set the temperature on the fan so that it is lower than the room temperature. Refer to Automatic Operating Instructions.
• Fan is not secure in my window and moves during operation.	• Fan may not be set in the window properly.	✓ Ensure that the bottom edge of the window sash fits into the groove along the top of the fan. Close the sash completely on top of the window so it is secure. Refer to the Window Fan Installation section.
• My window fan will not fit horizontally in the window.	• Fan may need to be installed vertically.	✓ Window fans can be installed either vertically or horizontally. Please note that when installing vertically, the internal adjustable extender panel must be located on the top of the window fan and never on the bottom. Refer to the Window Fan Installation section.
• My window fan has become dirty.	• Long term or continued use. This is normal when circulating unfiltered air.	✓ First unplug the fan from the outlet. The outside of the fan can be wiped down with a damp cloth. Use a vacuum cleaner with a dust brush attachment. Refer to the Cleaning/Maintenance Instructions section.

If you have any questions regarding your product or would like to learn more about other Bionaire® products, please contact our Consumer Service Department at 1-800-253-2764 or visit our website at [www.bionaire.com](http://www.bionaire.com).

## WARRANTY INFORMATION

### 5 YEAR LIMITED WARRANTY

Sunbeam Products, Inc. doing business as Jarden Consumer Solutions or if in Canada, Sunbeam Corporation (Canada) Limited doing business as Jarden Consumer Solutions (collectively "JCS") warrants that for a period of five years from the date of purchase, this product will be free from defects in material and workmanship. JCS, at its option, will repair or replace this product or any component of the product found to be defective during the warranty period. Replacement will be made with a new or remanufactured product or component. If the product is no longer available, replacement may be made with a similar product of equal or greater value. This is your exclusive warranty. Do NOT attempt to repair or adjust any electrical or mechanical functions on this product. Doing so will void this warranty.

This warranty is valid for the original retail purchaser from the date of initial retail purchase and is not transferable. Keep the original sales receipt. Proof of purchase is required to obtain warranty performance. JCS dealers, service centers, or retail stores selling JCS products do not have the right to alter, modify or any way change the terms and conditions of this warranty.

This warranty does not cover normal wear of parts or damage resulting from any of the following: negligent use or misuse of the product, use on improper voltage or current, use contrary to the operating instructions, disassembly, repair or alteration by anyone other than JCS or an authorized JCS service center. Further, the warranty does not cover: Acts of God, such as fire, flood, hurricanes and tornadoes.

#### What are the limits on JCS's Liability?

JCS shall not be liable for any incidental or consequential damages caused by the breach of any express, implied or statutory warranty or condition.

Except to the extent prohibited by applicable law, any implied warranty or condition of merchantability or fitness for a particular purpose is limited in duration to the duration of the above warranty.

JCS disclaims all other warranties, conditions or representations, express, implied, statutory or otherwise.

JCS shall not be liable for any damages of any kind resulting from the purchase, use or misuse of, or inability to use the product including incidental, special, consequential or similar damages or loss of profits, or for any breach of contract, fundamental or otherwise, or for any claim brought against purchaser by any other party.

Some provinces, states or jurisdictions do not allow the exclusion or limitation of incidental or consequential damages or limitations on how long an implied warranty lasts, so the above limitations or exclusion may not apply to you.

This warranty gives you specific legal rights, and you may also have other rights that vary from province to province, state to state or jurisdiction to jurisdiction.

#### How to Obtain Warranty Service

##### In the U.S.A.

If you have any questions regarding this warranty or would like to obtain warranty service, please call 1-800-253-2764 and a convenient service center address will be provided to you.

##### In Canada

If you have any questions regarding this warranty or would like to obtain warranty service, please call 1-800-253-2764 and a convenient service center address will be provided to you.

## WARRANTY INFORMATION

In the U.S.A., this warranty is offered by Sunbeam Products, Inc. doing business as Jarden Consumer Solutions located in Boca Raton, Florida 33431. In Canada, this warranty is offered by Sunbeam Corporation (Canada) Limited doing business as Jarden Consumer Solutions, located at 20 B Hereford Street, Brampton, Ontario L6Y 0M1. If you have any other problem or claim in connection with this product, please write our Consumer Service Department. **PLEASE DO NOT RETURN THIS PRODUCT TO ANY OF THESE ADDRESSES OR TO THE PLACE OF PURCHASE.**

# BIONAIRE®

pure indoor living



## REMOTE CONTROL TWIN WINDOW FAN

MODEL: BW2300

## Instruction Leaflet

Read instructions before operating. Retain for future reference.

Questions? Comments? Call 1-800-253-2764 in North America or visit our website at [www.bionaire.com](http://www.bionaire.com).

© 2013 Sunbeam Products, Inc. doing business as Jarden Consumer Solutions. All Rights Reserved.

Distributed by Sunbeam Products, Inc. doing business as Jarden Consumer Solutions, Boca Raton, Florida 33431.

153607/9100010013083

BW2300\_13EM1

Printed in China

GCDS-BI028341-JC

## PLEASE READ AND SAVE THESE IMPORTANT SAFETY INSTRUCTIONS

When using electrical appliances, basic safety precautions should always be taken including the following:

1. Read all instructions before using this appliance.
2. Use fan only for purposes described in the instruction manual.
3. To protect against electrical shock do not immerse unit, plug or cord in water or spray with liquids and plug the appliance directly into a 120V AC electrical outlet.
4. Close supervision is necessary when any appliance is used by or near children.
5. Unplug from outlet when not in use, when moving fan from one location to another, before putting on or taking off parts and before cleaning.
6. Avoid contact with moving parts.
7. Do not operate in the presence of explosive and/or flammable fumes.
8. To avoid fire hazard, NEVER place the cord under rugs or any parts near an open flame, cooking or other heating appliance.
9. Do not operate any appliance with a damaged cord or plug after the appliance malfunctions, or has been dropped/damaged in any manner. Discard fan or return to an authorized service facility for examination and/or repair.
10. Do not run cord under carpeting. Do not cover cord with throw rugs, runner, or similar coverings. Do not route cord under furniture or appliances. Arrange cord away from traffic area and where it will not be tripped over.
11. The use of attachments not recommended or sold by the appliance manufacturer may cause hazards.
12. Do not let the cord hang over the edge of a table, counter or come in contact with hot surfaces or leave exposed to high traffic areas.
13. Do not use outdoors.
14. To disconnect, grip plug and pull from wall outlet. Never yank on cord.
15. Always use on a dry, level surface.
16. Do not operate fan until fully assembled with all parts properly in place.
17. This product is intended for household use ONLY and not for commercial or industrial applications.
18. **WARNING:** To reduce the risk of fire or electric shock, do not use this fan with any solid-state speed control device.
19. This product employs overload protection (fuse). A blown fuse indicates an overload or short-circuit situation. If the fuse blows, unplug the product from the outlet. Replace the fuse as per the user servicing instructions (follow product marking for proper fuse rating) and check the product. If the replacement fuse blows, a short circuit may be present and the product should be discarded or returned to an authorized service facility for examination and/or repair.

## PLEASE READ AND SAVE THESE IMPORTANT SAFETY INSTRUCTIONS

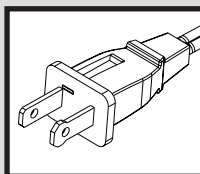

**THIS APPLIANCE HAS A POLARIZED PLUG (one blade is wider than the other). To reduce the risk of electric shock, this plug is intended to fit in a polarized outlet only one way. If the plug does not fit fully in the outlet, reverse the plug. If it still does not fit, contact a qualified electrician to install the proper outlet.**

**DO NOT ATTEMPT TO MODIFY THIS PLUG OR DEFEAT THIS SAFETY FEATURE IN ANY WAY.**

## FEATURES - OPERATIONS

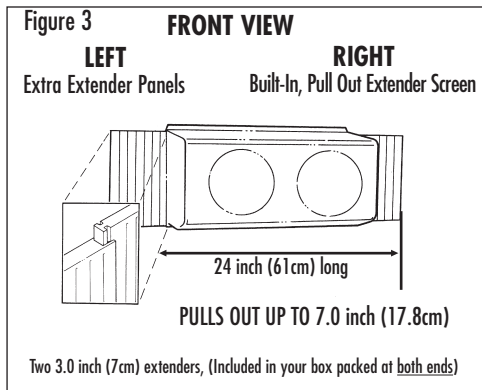
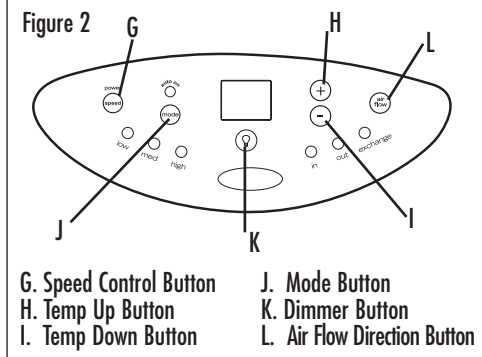
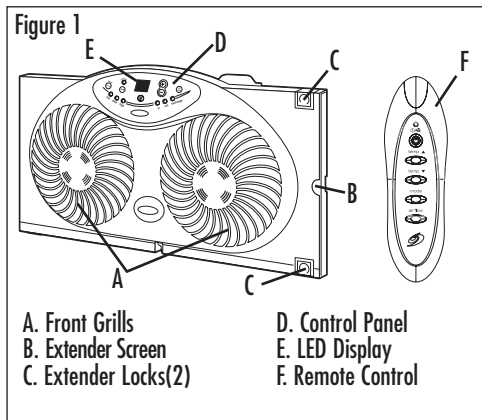

### INSTALLATION INSTRUCTIONS

#### Window Fan Installation

The window fan has been designed to fit double-hung, slider and casement windows.

- Step 1: Set the fan into your window opening.  
 Step 2: If the fan does not fit snugly to the top and bottom of the window casing, attach the included extender panel(s) and pull out the built-in extender screen until the fan fits safely in your window (See Figure 3).  
 Step 3: To keep the fan in place, carefully close the window so that the bottom edge of the window rests on the flat area on the top of the window fan.

**WARNING:** Be sure fan is securely installed in your window at all times. Do not lean or push on fan while it is in the window.

**NOTE:** For slider windows, set the fan vertically in your window opening, with the left side on the bottom.

### INSTALLATION GUIDE

The extender panels can be secured to the fan by simply sliding the extender panels into the grooves located on the left hand side of the fan.

The extender screen can be adjusted by pulling out the extender locks located on the top and bottom of the right side of the fan. Push the locks back into place to secure the extender screen at the desired length.

**For 24 inch to 27 inch (61-69cm):** Use up to 3 inch (7cm) of right side, pull out extender screen.

**For 28 inch to 34 inch (71-86cm):** Use one 3 inch (7cm) extender panel on the left side. Adjust the pull out extender screen on the right side for a tight fit (from 0.5 inch to 7 inch (1.3-17.8cm)).

**For 35 inch to 37 inch (89-94cm):** Use two 3 inch (7cm) extender panels on the left side. Adjust the pull out extender screen on the right side for a tight fit (from 0.5 inch to 7 inch (1.3-17.8cm)).

**Larger than 37 inch (94cm):** Additional extender panels will be required.

## FEATURES - OPERATIONS

### MANUAL OPERATING INSTRUCTIONS

**NOTE:** To operate the fan continuously, make sure that the auto on light located to the left of the control panel is off.

Step 1: Plug your window fan into any 120V AC electrical outlet.

**NOTE:** The temperature display will always be on when the fan is plugged into the electrical outlet.

Step 2: To turn the fan on press the Speed Control Button.  
 Step 3: Set the speed to high, medium (med) or low by pressing the Speed Control Button.

Step 4: Set the airflow direction to Exhaust (out), Intake (in) or exchange (one blade blowing air in and the second blade blowing air out) by pressing the air flow button.

Step 5: To turn the fan off press the Speed Control button and cycle through the speeds until the fan turns off or press and hold the Speed Control button until the fan turns off.

### AUTOMATIC OPERATING INSTRUCTIONS

Your window fan is equipped with the digital control thermostat that automatically turns the fan on and off depending upon the preset comfort level. For example, if you have set your thermostat to 75 °F/24 °C and the room temperature drops to 74 °F/23 °C or lower then the fan will automatically shut off. The fan will then turn on again when the room temperature exceeds 75 °F/24 °C. In order to take advantage of this feature, make sure your window fan is in automatic mode (this will be indicated by a red light on the left of the control panel).

Step 1: Set the fan to Automatic Mode by pressing the Mode button located on the Control Panel. The Auto On light will illuminate when the unit is in Automatic Mode.

Step 2: Press the Temp Set (+, -) buttons on the front of the Control Panel or use the remote control to program the desired temperature.

Step 3: When you are finished setting the temperature the display will blink. It will then return to displaying the current room temperature.

**IMPORTANT:** If the unit will not start in automatic mode, please make sure that the set temperature is below the current room temperature. If the fan is stopped and you would like to turn it back on, lower the set temperature or switch to the manual mode.

### FCC STATEMENT

#### Potential for Radio/Television Interference

This device complies with Part 15 of the FCC Rules. Operation is subject to the following two conditions: (1) This device may not cause harmful interference, and (2) this device must accept any interference received, including interference that may cause undesired operation.

This product has been tested and found to comply with the limits for a Class B digital device, pursuant to part 15 of the FCC rules.

These limits are designed to provide reasonable protection against harmful interference in a residential installation.

The product generates, uses, and can radiate radio frequency energy and, if not installed and used in accordance with the instructions, may cause harmful interference to radio communications. However, there is no guarantee that the interference will not occur in a particular installation. If the product does cause harmful interference to radio or television reception, which can be determined by turning the product on or off, the user is encouraged to try to correct the interference by one or more of the following measures:

- Reorient or relocate the receiving antenna.
- Increase the separation between the product and the receiver.
- Connect the product into an outlet on a circuit different from that to which the receiver is connected.
- Consult the dealer or an experienced radio/TV technician for help.
- Changes or modifications not expressly approved by the party responsible for compliance could void the user's authority to operate the equipment.

### REMOTE CONTROL

Requires 2 AAA batteries, 1.5V (not included).

## FEATURES - OPERATIONS CLEANING / STORAGE

### Battery Replacement

- a) Remove battery cover from remote control.
- b) Remove batteries from the remote control.
- c) Insert two new batteries, pressing them firmly into their slot.
- d) Replace the battery cover.

#### NOTES:

- Replace all batteries of a set at the same time.
- Being careful not to bend or damage the contact spring, clean the battery contacts and devices' contacts prior to installing the batteries.
- Remove the batteries from the equipment when it is not being used for an extended period of time.
- Remove the used batteries promptly.
- Do not mix old and new batteries. Do not mix alkaline, standard (carbon-zinc), or rechargeable batteries.
- Do not discard used batteries into household trash containers. Contact your local government for disposal or recycling practices in your area.

### CLEANING/MAINTENANCE INSTRUCTIONS

Follow these instructions to correctly and safely care for your fan. Please remember:

#### REPLACEABLE FUSE

If your (5 Amp, 125 Volt) replaceable fuse blows, please order a new fuse at 1-800-253-2764. Follow the below instructions to replace the fuse on the plug.

#### User Servicing Instructions

1. Unplug your fan. Grasp plug and remove from the receptacle or other outlet device. Do not unplug by pulling on cord.
2. Open fuse cover, located on the top of the plug, by using your thumb or a flathead screwdriver to slide the cover down towards the prongs.

**NOTE:** Ensure that fuse cover is completely open before attempting to remove fuse.  
 3. Remove fuse carefully by using a small screwdriver to pry the fuse out of the compartment by the metal ends of the fuse. (see Figure 4)

4. Place plug on a solid, flat surface. Insert new 5 Amp, 125 Volt fuse into fuse compartment and use a small

screwdriver to secure the metal ends of the fuse into the compartment.  
**CAUTION:** Risk of fire. Replace fuse only with 5 Amp, 125 Volt fuse.

5. Slide fuse cover closed completely. If fuse cover is difficult to close, make sure fuse is secured in place completely by pressing down on metal ends of the fuse.
6. Risk of fire. Do not replace attachment plug. Contains a safety device (fuse) that should not be removed. Discard product if the attachment plug is damaged.

#### FAN CLEANING

- Always unplug the fan before cleaning.
  - Do not allow water to drip on or enter into fan housing.
  - Be sure to use a soft cloth moistened with a mild soap solution.
  - Do not use gasoline, thinner or benzene as a cleaner.
- Clean the fan grills, extender screen, and extender panels with a soft, damp cloth. Please use caution around the motor housing area. Do not allow the motor or other electrical components to be exposed to water. Also, using a soft bristle brush attachment, a vacuum cleaner may be used to extract dust buildup on the grill areas.

**NOTE:** Remember to turn your fan to the off position prior to cleaning.

#### FAN STORAGE INSTRUCTIONS

Your fan can be stored in the off-season, however it is important to keep it in a safe, dry location.

- We recommend using the original (or appropriately sized) box.
- Remember to protect the fan from dust.

#### WINDOW FAN ACCESSORIES

Window Fan Extender Panel (2310010000420)		To order please go to www.bionaire.com or call 1-800-253-2764
--	--	---

