

User Manual

SOLENNE SERIES



*Wall mounted
premix condensing boiler*

If you smell gas ...

- **DO NOT ACTIVATE ANY ELECTRIC SWITCHES, TELEPHONES OR ANY OTHER DEVICE THAT MAY GENERATE ELECTRICAL DISCHARGES OR SPARKS.**
- **OPEN DOORS AND WINDOWS IMMEDIATELY TO CREATE A CURRENT OF AIR THAT WILL RAPIDLY CLEAR THE ROOM.**
- **CLOSE ALL GAS TAPS AND VALVES.**
- **CALL FOR PROFESSIONALLY QUALIFIED PERSONNEL FROM A NEAR BY TELEPHONE.**

[User instructions](#)

BOILER OPERATING INSTRUCTIONS

-  Make sure that the authorized technician who tested the boiler has documented the test results including gas pressure, CO₂, flue gas temperature and safety device functions.
-  The installation, first start-up, regulation and maintenance operations must be carried out by qualified personnel. Incorrect installation or maintenance can cause damage to property and injury to persons or animals, for which the manufacturer will not be held responsible.

During the installation, the technician must carry out the following checks:

- *The data on the data plate must correspond to that of the utility networks to which it will be connected (gas, electricity, water).*
- *The boiler must be regulated according to its designed use and performance.*
- *The flue gas exhaust and combustion air intake system must be correctly installed and operational.*
- *The exhaust gas discharge and ventilation systems must comply with the requirements of national and local standards regardless of whether the boiler is installed indoors, outdoors or in its own cabinet (see section "Reference standards").*

General warnings

- ➡ If there is any doubt as to whether the appliance has been tested by an authorised technician, do not attempt to start it. All maintenance and gas conversion operations **MUST BE CARRIED OUT BY PROFESSIONALLY QUALIFIED PERSONNEL**, registered in accordance with current legislation.
- ➡ ***Make sure that the requirements relating to the air intake and ventilation of the room in which the boiler is to be installed have been complied with.***
- ➡ The boiler is fitted with an antifreeze system. If the boiler is installed in a location where there is a risk of freezing, the anti-freeze system will only come into operation if the power is on and the gas supply valve is open (the frost protection is active even with the ON/OFF switch in OFF position). The manufacturer will not be held responsible for damage to the boiler caused by non-compliance with this instruction.
- ➡ Should any part of the boiler freeze-up, do not attempt to light it under any circumstances, but instead call a qualified service company immediately.
- ➡ The appliance's combustion system must be checked every one year. This check includes testing the efficiency of the boiler and must be carried out by authorized personnel possessing the qualifications as required by current law.
- ➡ Do not obstruct the ventilation openings in rooms where there are gas-burning appliances installed (boiler, cooker, etc.).

If you smell gas ...

- ➔ **DO NOT ACTIVATE ANY ELECTRIC SWITCHES, TELEPHONES OR ANY OTHER DEVICE THAT MAY GENERATE ELECTRICAL DISCHARGES OR SPARKS.**
- ➔ **OPEN DOORS AND WINDOWS IMMEDIATELY TO CREATE A CURRENT OF AIR THAT WILL RAPIDLY CLEAR THE ROOM.**
- ➔ **CLOSE ALL GAS TAPS AND VALVES.**
- ➔ **CALL FOR PROFESSIONALLY QUALIFIED PERSONNEL FROM A NEAR BY TELEPHONE.**

Boiler controls - Control panel

LEGEND

1. ON/OFF SWITCH
2. HEATING TEMPERATURE CONTROL KNOB
3. D.H.W TEMPERATURE CONTROL KNOB.
4. D.H.W TEMPERATURE DISPLAY BUTTON. (KEEP PRESSED FOR 5 SECONDS TO DISPLAY OUTSIDE TEMPERATURE -ONLY WITH OPTIONAL OUTDOOR SENSOR)
5. SERVICE BUTTON.
6. SUMMER, WINTER OR SUMMER/WINTER MODE SELECTION BUTTON.
7. TERMINAL BOARD FOR EXTERNAL WIRING.
8. TEMPERATURE, ERROR CODE AND OPERATING STATUS DISPLAY.

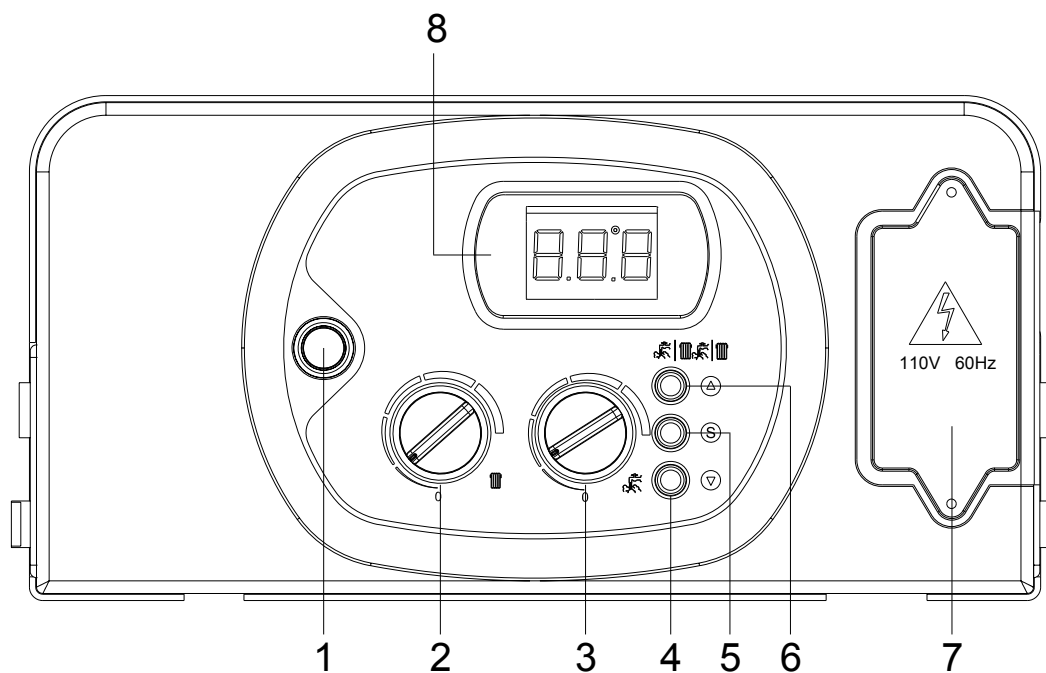

Fig. 1

Starting - up the boiler

- Open the gas Isolation valve located under the boiler.
- Switch on the boiler by placing the ON/OFF switch (1) in the **ON** position (see “Control panel”).
- The boiler will light automatically (with the WINTER mode selected and room thermostat connected).
- Check that there are no flashing numbers on the display 8 (see error codes). If code **H2O** appears on the display 8 this denotes that there is no water in the boiler. Consequently, fill the system as described in section “Filling the system”.

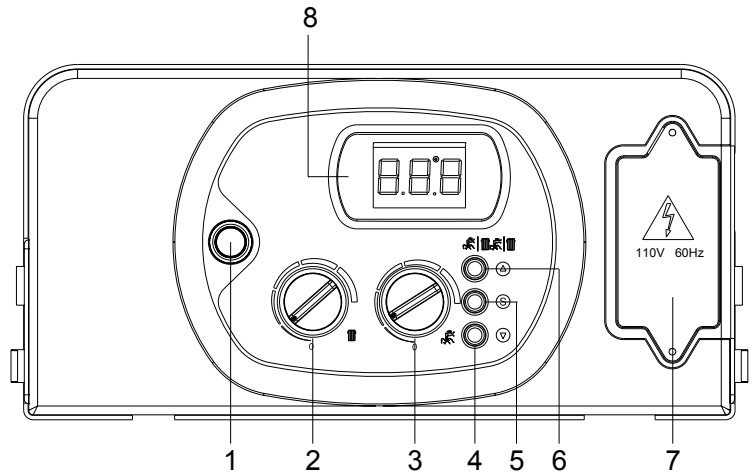

Fig. 1

■ “SUMMER” mode

To switch boiler operation to “SUMMER” mode, press button 6 (see fig. 1). The boiler will only work for the D.H.W system. The “SUMMER” mode setting of the boiler is signalled by the symbol lit continuously on the control panel.

The automatic ignition system will light the burner every time there is a demand for domestic hot water. In this case, the symbol on the control panel will flash.

■ “WINTER” mode

To switch boiler operation to “WINTER” mode, press button 6 (see fig. 1). The boiler will only work for the central heating system. The “WINTER” mode setting of the boiler is signalled by the symbol lit continuously on the control panel.

The automatic ignition system will light the burner every time there is a demand for room heating. In this case, the symbol on the control panel will flash.

■ “SUMMER-WINTER” mode

To switch boiler operation to “SUMMER/WINTER” mode, press button 6 (see fig. 1). The boiler will work for both central heating/D.H.W systems. The “SUMMER/WINTER” mode setting of the boiler is signalled by the symbols lit continuously on the control panel.

The automatic ignition system will light the burner every time there is a demand for room heating or domestic hot water, the functioning is signalled by the symbols flashing continuously on the control panel.

■ Regulating the heating temperature

The heating temperature is regulated by knob 2 (see fig.1).

- Rotating the knob counter-clockwise reduces the temperature.
- Rotating the knob clockwise increases the temperature.
- The range of temperature settings for the central heating runs from a minimum of 86°F to a maximum of 176°F, or, in the case of low temperature operation, from a minimum of 77°F to a maximum of 138°F.

■ **D.H.W temperature control**

The domestic hot water temperature is regulated by knob 3 (see “Control panel”).

- Rotating the knob counter-clockwise reduces the temperature.
- Rotating the knob clockwise increases the temperature.
- The range of temperature settings for the domestic hot water runs from a minimum of 95°F to a maximum of 160°F.

■ **Topping-up the system with water**

The water pressure in the central heating circuit must be checked during the entire period of operation of the boiler. In this respect, the reading on the pressure gauge **M** (fig. 2), located on the lower part of the boiler, must not be less than 1 bar (14.5 psi).

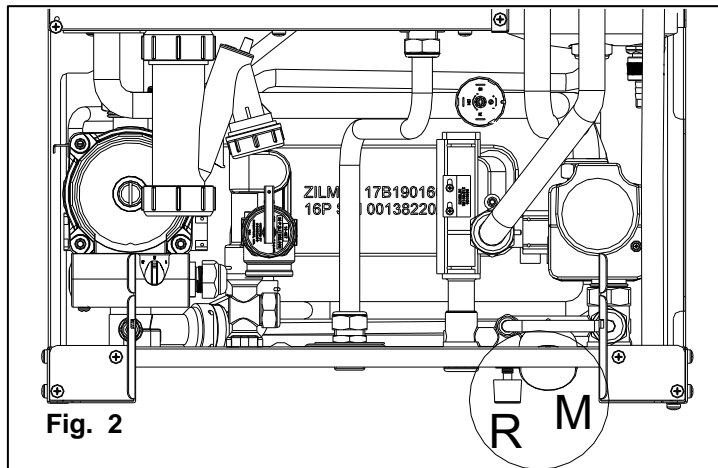

Fig. 2

If there is insufficient water in the boiler, the code **H2O** will flash on the display (see fig 1).

To bring the system back up to pressure, open the external filling tap **R** (fig. 2) and use the pressure gauge **M** (fig. 2) to check that the system pressure reaches 1 bar (14.5 psi) and that the code H2O lights up.

When the operation is complete, close the fill tap.

Diagnostics – Error codes:

This paragraph contains a list of error codes that the boiler may generate on the display **8** (see “Control panel”) together with the relative indications and the operations that the user can carry out to reset the boiler.

⚠ If the problem re-occurs after the following actions have been taken; call for service.

E01 Ionisation block

Code **E01** lit continuously on the display.

- Check that the gas valve on the boiler and gas meter are open and that there is gas in the mains supply (or in the tank).
- Switch off then switch on the appliance using switch 1 (see “Control panel”) on the control panel.
- When the error code on the display disappears, the boiler will restart.

If the problem persists, **Call for Service**.

E02 Safety Thermostat tripped

Code **E02** lit continuously on the display. **Call for Service**.

E03 Flue Gas Thermofuse tripped

Code **E03** lit continuously on the display. **Call for Service**.

h2o Water Pressure Switch tripped

Code **H2O** lit continuously on the display.

- Check the water pressure in the central heating circuit. The reading on the pressure gauge **M** (see fig. 2), located on the lower part of the boiler, must not be less than 1 bar .
- If the pressure is less than 1 bar (14.5 psi), top-up the system as described in paragraph “Filling the system”.
- The boiler will restart automatically.

If the problem persists, **Call for Service**.

E05 Heating Sensor malfunction

Code **E05** lit continuously on the display. **Call for Service.**

E12 D.H.W Storage Cylinder Sensor Malfunction

Code **E12** lit continuously on the display. **Call for Service.**

E16 Electric Fan Malfunction

Code **E16** lit continuously on the display. **Call for Service.**

E22 Parameter programming request

Code **E22** lit continuously on the display. **Call for Service.**

E35 Flame Detection Malfunction

Code **E35** lit continuously on the display. **Call for Service.**

E42 Fan Speed P.C.B. malfunction

Code **E42** lit continuously on the display. **Call for Service.**

NOTE: If the boiler is to be left unused for a long period of time, the user must do one of the following:

- *Make the boiler safe* by disconnecting all the power supplies (electricity and gas), and draining the heating system and the condensate trap.
- Leave the boiler in *standby*, leaving the electricity and gas supplies connected and, consequently the anti-freeze function.



PNA, Inc
34 Coffin Ave Brewer, ME 04412
P. 207-942-3636 F. 207-942-3737
www.pensotti-pna.com