

TPS3 Internal Manual

Surge Protective Device

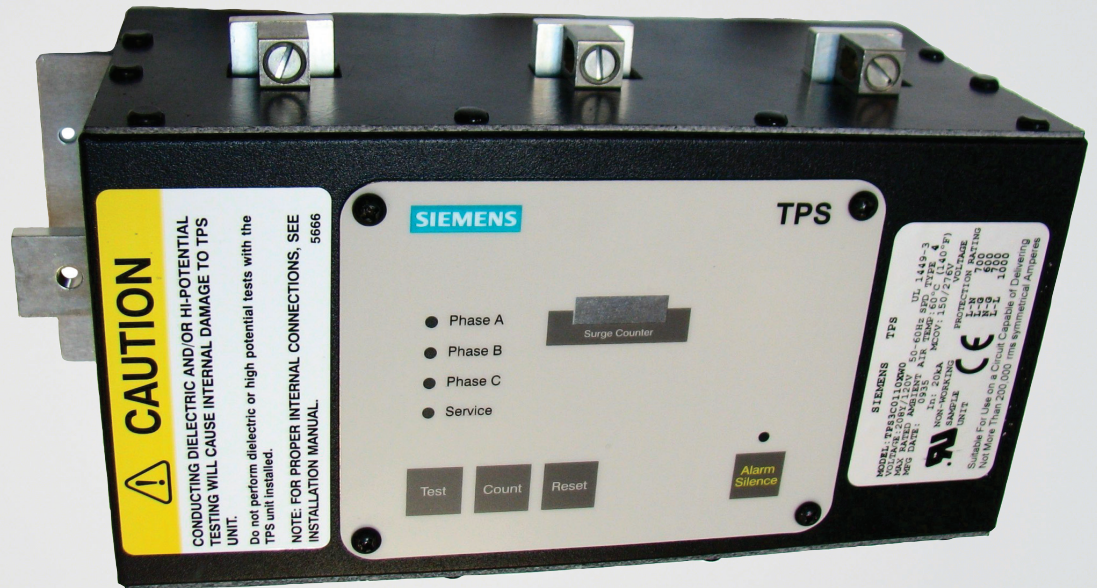

User Manual - USA

SIEMENS



WARNING - Hazardous Voltage & Shock Hazard

Failure to Follow These Instructions Could Result in Death or Serious Injury

- Only qualified licensed electricians should install or service SPDs
- Hazardous voltages exist within SPDs
- SPDs should never be installed or serviced when energized
- Use appropriate safety precautions including Personal Protection Equipment
- Failure to follow these instructions can result in death, serious injury, and/or equipment damage.
- This manual shall be read in entirety prior to installing

Bonding and Grounding Hazard

Verify that the neutral conductor in the service entrance equipment is bonded to ground in accordance with the National Electrical Code (NEC®) and all applicable codes.

Verify that the neutral terminal (XO) on the secondary side of distribution transformers are grounded to the system ground in accordance with the NEC® and all applicable codes.

During installation into an electrical system the SPD must not be energized until the electrical system is completely installed, inspected and tested. All conductors must be connected and functional including the neutral (if required). The voltage rating of the SPD and system must be verified before energizing the SPD.

Failure to follow these guidelines can lead to abnormally high voltages at the SPD. This may cause the SPD to fail. The warranty is voided if the SPD is incorrectly installed and/or if the neutral conductor in the service entrance equipment or downstream of separately derived systems is not bonded to ground in accordance with the NEC®.

Do Not Hi-Pot Test SPDs

Any factory or on-site testing of power distribution equipment that exceeds normal operating voltage such as high-potential insulation testing, or any other tests where the suppression components will be subjected to higher voltage than their rated Maximum Continuous Operating Voltage (MCOV) must be conducted with the SPD disconnected from the power source. For 4-wire systems, the neutral connection at the SPD must also be disconnected prior to performing high-potential testing and then reconnected after test completion.

Failure to disconnect SPD and associated components during elevated voltage testing will damage the SPD and will void the warranty.

Table of Contents

Failure to Follow These Instructions Could Result in Death or Serious Injury	2
Do Not Hi-Pot Test SPDs	2
Introduction	1
Warning and Safety Information	1
Qualified Person	1
Danger	1
Warning	1
Caution	1
Do Not Hi-Pot Test SPDs	1
Limited Warranty	1
Unpacking and Preliminary Inspection	1
Storage	2
Industry Standards Changes - 2009	2
Siemens TPS3 SPDs have the following Type designations	2
Equipment Performance	2
Voltage Rating	2
General Information	4
Precautionary Statement Regarding SPDs on Ungrounded Systems	4
Overcurrent Protection	4
System Grounding	4
Environment	4
Audible Noise	4
Dead front modification Instruction Changes for P1 SPD Instructions	4
P1 Dead Front Knockout Plate Removal Instructions	4
TPS3 01 Installation Instructions for: Lighting Panelboards Type P1, P2, P3	5
TPS3 01 Installation Instructions for: 400/600 amp S1/S2 and All SE Panels	6
UL 1283 required language concerning the installation of EMI Filters	7
W option Suffix:	7
TPS3 05 and TPS3 06 Module Replacement Instructions	8
TPS3 01 and TPS3 06 Module Installation Instructions: MCC	9
Operation	10
TPS3 Control and Diagnostic Display Panel	10
Display Panel with Surge Counter Option	10
Dry Contacts Feature	10
Maintenance	11
Troubleshooting & Service	11
Abnormal N-G Voltage Indicators	11
Module Replacement & Service	11
Technical Support	12
Display Replacement	12
Preventive Maintenance (Inspection and Testing)	12
Corrective Maintenance (Repair)	12
Figures	
Figure 1: SPD Types	2
Figure 2: Dead Front Modification Instruction	4
Figure 3: 250 AMP Max P1 Panels	5
Figure 4: 400/600 AMP S1/S2 AND ALL SE PANELS - TPS3 01 Unit with the NK Accessory Kit	6
Figure 5: P4, P5 AND Front Connected Distribution Switchboards	8
Figure 6: Service Section Switchboards and low voltage Switchgear	8
Figure 7: Installation in a MCC	9
Figure 8: BASIC DISPLAY - HORIZONTAL	10
Figure 9: BASIC DISPLAY - VERTICAL	10
Figure 10: DRY CONTACT PIN CONFIGURATION	10
Tables	
Table 1: TYPE DESIGNATIONS	5
Table 2: MODEL NUMBER DECODER	6
Table 3: CONTENTS FOR INSTALLATION IN Lighting Panelboards Type P1, P2, P3	8
Table 4: CONTENTS for installation in 400/600 amp S1/S2 and All SE Panels	9

Introduction

Thank you for choosing Siemens TPS3 Surge Protective Device (SPD). This is a high quality, high energy surge suppressor designed to protect sensitive equipment from damaging transient overvoltages.

Proper installation is important to maximize performance. Please follow the steps outlined herein.

This entire user manual should be read prior to beginning installation. These instructions are not intended to replace national or local codes. Follow all applicable electrical codes to ensure compliance. Installation of this SPD should only be performed by qualified electrical personnel.

All Siemens SPDs are extensively tested in accordance with industry standards such as ANSI/IEEE C62.41.1, C62.41.2, C62.45, C62.62, C62.72, UL 1449, UL 1283, IEC 61643, etc.

Warning and Safety Information

This equipment contains hazardous voltages. Death, serious injury, or property damage can result if safety instructions are not followed. Only qualified personnel should work on or around this equipment after becoming thoroughly familiar with all warnings, safety notices, and maintenance procedures contained herein.

The successful and safe operation of this equipment is dependent upon proper handling, installation, operation, and maintenance.

Qualified Person

For the purposes of this manual and product labels, a QUALIFIED PERSON is one who is familiar with the installation, construction, and operation of this equipment, and the hazards involved. In addition, he or she has the following qualifications:

- (a) Is trained and authorized to energize, deenergize, clear, ground and tag circuits and equipment in accordance with established safety practices.
- (b) Is trained in the proper care and use of personal protective equipment (PPE) such as rubber gloves, hard hat, safety glasses or face shields, flash clothing, etc. in accordance with established safety practices.
- (c) Is trained in rendering first aid.

Danger

For the purposes of this manual and product labels, DANGER indicates an imminently hazardous situation, which, if not avoided, will result in death or serious injury.

Warning

For the purposes of this manual and product labels, WARNING indicates failure to following these instructions can result in death, serious injury, or equipment damage.

Caution

For the purposes of this manual and product labels, CAUTION indicates a potentially hazardous situation which, if not avoided, could result in minor or moderate injury.

These instructions do not purport to cover all details or variations in equipment, nor to provide for every possible contingency to be met in connection with installation, operation or maintenance. Should further information be desired or should particular problems arise which are not covered sufficiently for the purchaser's purposes, the matter should be referred to the local Siemens sales office.

Do Not Hi-Pot Test SPDs

Any factory or on-site testing of power distribution equipment that exceeds normal operating voltage such as high-potential insulation testing, or any other tests where the suppression components will be subjected to higher voltage than their rated Maximum Continuous Operating Voltage (MCOV) must be conducted with the SPD disconnected from the power source. For 4-wire systems, the neutral connection at the SPD must also be disconnected prior to performing high-potential testing and then reconnected after test completion.

Failure to disconnect SPD and associated components during elevated voltage testing will damage the SPD and will void the warranty.

Limited Warranty

Siemens warrants its AC Panel protection products against defective workmanship and materials for 10 years. Liability is limited to the repair or replacement of the defective product at Siemens' option. A Return Material Authorization number (RA#) must be given by the company prior to the return of any product. Returned products must be sent to the factory with the transportation charges prepaid. In addition, the company also warrants unlimited replacement of modular and component parts within the warranty period previously described.

The company specifically disclaims all other warranties, expressed or implied. Additionally, the company is not be responsible for incidental or consequential damages resulting from any defect in any product or component thereof.

The sales contract contains the entire obligation of Siemens. This instruction manual shall not become part of or modify any prior existing agreement, commitment or relationship.

Unpacking and Preliminary Inspection

Inspect the entire shipping container for damage or signs of mishandling before unpacking the unit. Remove the packing material and further inspect the unit for any obvious shipping damages. If any damage was found and is a result of shipping or handling, immediately file a claim with the shipping company and forward a copy to your local Siemens sales office.

Storage

The unit should be stored in a clean, dry environment. Storage temperature is -55°C (-67°F) to $+85^{\circ}\text{C}$ ($+185^{\circ}\text{F}$). Avoid exposing the unit to areas of high condensation. All of the packaging materials should be left intact until the unit is ready for installation. If the unit has been stored for an extended period of time, it may be necessary to clean the unit and make a complete inspection of the unit prior to installing and placing into service.

Industry Standards Changes - 2009

UL 1449 Third Edition and 2008 NEC® Article 285 generated substantial changes.

- The term TVSS changed to SPD
- Types 1, 2, 3 & 4 SPDs are created
- UL 1449 clamping voltage performance testing changed from 500A to 3,000A
- UL 1449 added new Nominal Discharge Current testing (I nominal, or In), which consists of more rigorous duty-cycle testing

The SPD Type category is important to understand before installing any SPD. Type 1 and 2 SPDs are fully UL Listed devices whereas Type 4 SPDs are UL Recognized devices.

Type 1 – Installed on line or load side of the Main Overcurrent Protection (OCP), similar to obsolete products known as Secondary Surge Arrestors, except now includes rigorous safety testing. Includes all OCP & safety disconnectors inside the SPD.

Type 2 – Installed on load side of the Main OCP, similar to previous products known as TVSS. May or may not require external OCP.

Type 3 – Point of Utilization, direct plug in type devices, surge strips, etc. These devices are intended for installation 10 meters from the panel (rationale based on IEEE Cat. A location).

Type 4 – Surge suppression components, could be a basic component or a complete module. Type 4 components can be tested for Type 1, Type 2 or Type 3 applications.

Figure 1: SPD Types

2008 NEC Art 285 & UL 1449-3

SPD Types: Types 1, 2, 3, & 4

Based on Location within electrical distribution system
(also coincides with ANSI/IEEE C62.41.2 - 2002 Categories C, B & A)

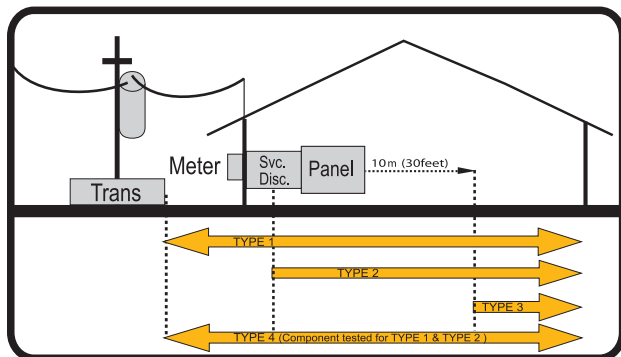

Siemens TPS3 SPDs have the following Type designations

Table 1: Type Designations

SIEMENS TPS3 SERIES	TYPE RATING
TPS3 01 & L1	Type 4 for Type 1 applications
TPS3 05 & L5	Type 1
TPS3 06 & L6	Type 4 for Type 1 applications

For further information, please review latest editions of NEC® Art. 285, UL 1449, contact your local Siemens sales office or contact Siemens TPS Tech Support at (888) 333-3545.

Equipment Performance

As SPDs sense overvoltage, they create a momentary internal short circuit, thereby redirecting harmful surge energy to earth ground. SPDs are capable of repeating this function repeatedly. For optimum protection, staged surge suppression should be implemented at the service entrance and all other distribution or panelboard locations feeding sensitive equipment.

Voltage Rating

Prior to installing the TPS3 SPD, verify that the unit has the correct voltage rating for the equipment installed by checking the nameplates of both the equipment and TPS3 module. The service type should match the intended power source. See Table 2 on the following page for voltage applications.

Table 2: Model Number Decoder

TPS SERIES DESCRIPTION	
TPS3 01	SPD for P1, P2, P3 Lighting and Power Distribution Panelboards, MCC and Busway
TPS3 L1	10 Mode SPD for SPD for P1, P2, P3 Lighting and Power Distribution Panelboards, MCC and Busway
TPS3 05	SPD for P4 & P5 Panelboards and Distribution Switchboards
TPS3 L5	10 Mode SPD for P4 & P5 Panelboards and Distribution Switchboards
TPS3 06	SPD for SB1, SB2, SB3, Type RCS Switchboards, MCC and Busway
TPS3 L6	10 Mode SPD for SB1, SB2, SB3, Type RCS Switchboards, MCC and Busway

AVAILABLE VOLTAGES						
VOLTAGE CODES	TPS3 01	TPS3 L1	TPS3 05	TPS3 L5	TPS3 06	TPS3 L6
A = 240/120V Split Phase 1Ø, 3W Plus Grnd (Fig 1)	√	√	√	√	√	√
B = 240/120V 3Ø, High Leg Delta (B High) (Fig 3)	√	√	√	√	√	√
C = 208Y/120V 3Ø, 4W Plus Grnd (Fig 2)	√	√	√	√	√	√
D = 240V 3Ø, 3W Plus Grnd (Fig4)	√		√		√	
E = 480Y/277V 3Ø, 4W Plus Grnd (Fig 2)	√	√	√	√	√	√
F = 480V 3Ø, 3W Plus Grnd (Fig 4)	√		√		√	
G = 600V 3Ø, 3W Plus Grnd (Fig 4)	√		√		√	
K = 380Y/220V 3Ø, 4W Plus Grnd (Fig 2)	√	√	√	√	√	√
L = 600Y/347V 3Ø, 4W Plus Grnd (Fig 2)	√		√		√	
S = 400Y/230V 3Ø, 4W Plus Grnd (Fig 2)	√	√	√	√	√	√

AVAILABLE SURGE CURRENT RATING						
SURGE CURRENT RATING	TPS3 01	TPS3 L1	TPS3 05	TPS3 L5	TPS3 06	TPS3 L6
10 = 100kA per phase	√		√		√	
15 = 150kA per phase	√	√	√	√	√	√
20 = 200kA per phase	√		√		√	
25 = 250kA per phase	√		√		√	
30 = 300kA per phase	√	√	√	√	√	√
40 = 400kA per phase					√	
45 = 450kA per phase					√	√
50 = 500kA per phase					√	

AVAILABLE OPTIONS (When Option is Not Selected Include a "0" in the Field)						
OPTION CODE / DESCRIPTION	TPS3 01	TPS3 L1	TPS3 05	TPS3 L5	TPS3 06	TPS3 L6
X = Surge Counter	√	√	√	√	√	√
W = Terminal Lugs (for circuit breaker connection) - used with P1, P2, P3 panels only	√	√				
B = Busway Application	√	√			√	√
M = MCC Application	√	√			√	√

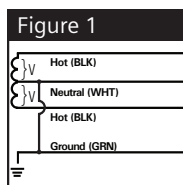

SPLIT
2 Hots, 1 Neu, 1 Grnd

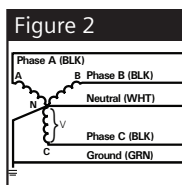

WYE
3 Hots, 1 Neu, 1 Grnd

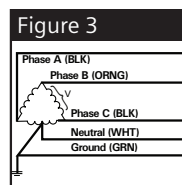

HI-LEG DELTA (B High)
3 Hots, (B HIGH),
1 Neu, 1 Grnd

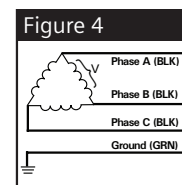

DELTA & HRG WYE
3 Hots, 1 Grnd

General Information

This device features internal overcurrent and overtemperature protection that will disconnect affected surge suppression components at the end of their useful life, but will maintain power to the load – now unprotected. If this situation is undesirable for the application, follow these instructions for servicing or replacing the device.

Service of this unit consists of replacing the internal module and/or display assembly.

There are no user-serviceable parts inside the replaceable module. Do not attempt to disassemble the module as it stores charge.

Precautionary Statement Regarding SPDs on Ungrounded Systems

Caution – Ungrounded systems are inherently unstable and can produce excessively high line-to-ground voltages during certain fault conditions. During these fault conditions, any electrical equipment including an SPD, may be subjected to voltages which exceed their designed ratings. This information is being provided to the user so that an informed decision can be made before installing any electrical equipment on an ungrounded power system.

Overcurrent Protection

The TPS3 SPD unit draws very little current under normal operation and will only conduct current for a very brief duration upon encountering a transient surge. The TPS3 unit contains overcurrent and thermal protection to protect against abnormal overvoltage conditions.

System Grounding

An equipment grounding conductor must be used on all electrical circuits connected to the SPD.

For the best performance, use a single point ground system where the service entrance grounding electrode system is connected to and bonded to building steel, metallic piping, driven rods, etc. (NEC and IEEE Std 142-2007 are appropriate standards).

For sensitive electronics and computer systems, ground impedance should be as low as possible. When metallic raceway is used as an additional grounding conductor, an insulated grounding conductor should be run inside the raceway and sized per the NEC. Adequate electrical continuity must be maintained at all raceway connections. Do not use isolating bushings to interrupt a metallic raceway run.

A separate isolated ground for the SPD is NOT recommended because it may isolate the SPD from the rest of the electrical system, thus decreasing performance. Proper equipment connections to grounding system and ground grid continuity should be verified via inspections and tested on a regular basis as part of a comprehensive electrical maintenance program.

On 4-Wire Power Systems, neutral to ground bonding (Main Bonding Jumper) must be installed per the NEC[®]. Failure to do so WILL damage SPDs.

Environment

The unit is designed to operate inside the equipment in a room ambient temperature range of: -40° C (-40° F) to +60° C (+140° F) with relative humidity of 0%-95% (non-condensing).

Audible Noise

The SPD's background noise is negligible which permits installation within the equipment in almost any room.

Dead front modification Instruction Changes for P1 SPD Instructions

The TPS3 unit requires a dead front opening to display its face plate. Remove any installed cover from a dead front opening at the TPS3 module location. If there is no dead front opening, follow the instructions in Fig. 2 to create an opening by removing a knockout plate.

P1 Dead Front Knockout Plate Removal Instructions

Stand the removed dead front on the floor with the plate to be removed in the upper position, as shown below. Grasping the upper edge of the dead front, press the cover plate out of the cutout.

Figure 2: Dead Front Modification Instruction

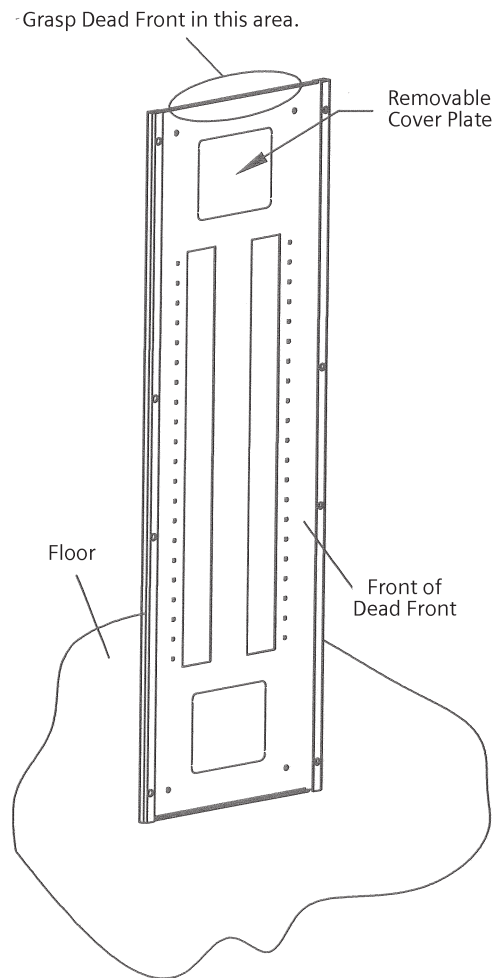



⚠ DANGER

Hazardous voltage.
Will cause death or serious injury.
 Keep Out.
 Qualified personnel only.
 Disconnect and lock off all power before working on this equipment.

⚠ CAUTION

CONDUCTING DIELECTRIC AND/OR HI-POTENTIAL TESTING WILL CAUSE INTERNAL DAMAGE TO TPS3 UNIT.
 Do not perform dielectric or high potential tests with the TPS3 unit installed.

TPS3 01 Installation Instructions for: Lighting Panelboards Type P1, P2, P3

If model number includes W option suffix, additional instructions follow

The following instructions are for the installation of the Siemens TPS3 01 and L1 SPD modules in Siemens Type P1 lighting panelboard. All hardware is supplied for complete installation of the TPS3 module. See page 2, Table 1 for Catalog numbers.

Figure 3: 250 AMP Max P1 Panels

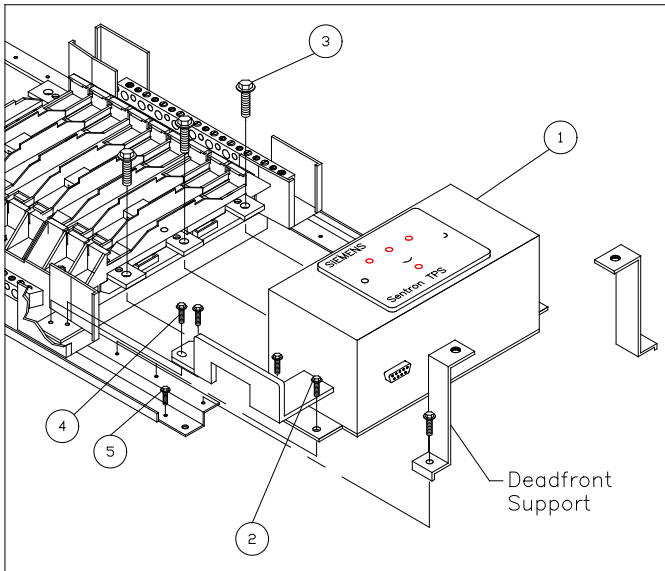

Table 3: Content for Installation in Lighting Panelboards Type P1, P2, P3

Item	Description	Qty.
1	TPS3 (See Page 2, Table 1)	1
2	#0-32 x 1/4 Slotted Hex Thread Forming Screw	4
3	1/4-20 Hex Head SEMS Assembly	3
4	#10-24 Slotted Hex Thread Forming Screw	2
5	#10-32 x 5/8 Slotted Hex Therad Forming Screw	4

Determine the mounting location of the TPS3 in the distribution equipment. If it is to be mounted in the top of the distribution equipment or relocated after installation, internal phase labeling connections must be changed to ensure proper diagnostic board indication. These modifications should be made prior to installation. If the TPS3 module is field installed in the bottom, or if it is mounted in a factory assembled panelboard, the internal phase label connections are correct as shipped.

Internal Phase Labeling Connections

A single 14 wire ribbon cable is attached to the display pcb. When the ABC phase sequence changes to CBA, the single connector is removed from the normal "ABC" jack and installed in the jack labeled "CBA"

Lock off all power supplying this equipment before working on it.

Remove the trim and dead front.

Remove the two (2) deadfront supports.

Position the TPS3 unit on the panel base rail so that the TPS3 neutral connector is in front of the panel neutral and the phase tabs are behind the interior bus. Slide the unit toward the interior until the four mounting holes line up with the four holes in the base rail.

Note: If a neutral lug is mounted in the position where the TPS3 neutral connection is made, it must be moved to one of the three remaining neutral lug positions prior to TPS3 installation.

Attach the TPS3 unit (item 1) to the base rail using four (4) of the #10-32 slotted hex washer head thread forming screws (item 2) provided as shown in Figure 1.

Fasten unit to the main bus using the 1/4-20 hex head (with captive washer) assembly machine screws (item 3) provided. Do not tighten at this time.

Fasten TPS3 neutral to panel neutral using two (2) #10-24 slotted hex washer head thread forming screws (item 4).

If the four (4) interior leveling screws are not already installed four (4) additional screws (item 5) are provided for installation to ensure proper ground path for TPS3 module.

Torque all connections to the values as specified on the installation and maintenance instruction label affixed to the rear of the dead front.

Replace deadfront supports by installing screws, finger tight. Then tighten with tool. Replace trim.



DANGER

Hazardous voltage.
Will cause death or serious injury.
 Keep Out.
 Qualified personnel only.
 Disconnect and lock off all power before working on this equipment.



CAUTION

CONDUCTING DIELECTRIC AND/OR HI-POTENTIAL TESTING WILL CAUSE INTERNAL DAMAGE TO TPS3 UNIT.
 Do not perform dielectric or high potential tests with the TPS3 unit installed.

TPS3 01 Installation Instructions for: 400/600 amp S1/S2 and All SE Panels

If model number includes W option suffix, additional instructions follow

Note that this installation is very similar to TPS3 used in S3 Panels except that the neutral connector is wired rather than pigtailed and the neutral connector is at line end of the panel.

The following instructions are for the installation of Siemens TPS3 01 and L1 SPD modules in Siemens 400/600 amp S1/S2 and all SE Panels. All hardware is supplied for complete installation of the TPS3 module.

Figure 4: 400/600 AMP S1/S2 AND ALL SE PANELS - TPS3 01 Unit with the NK Accessory Kit

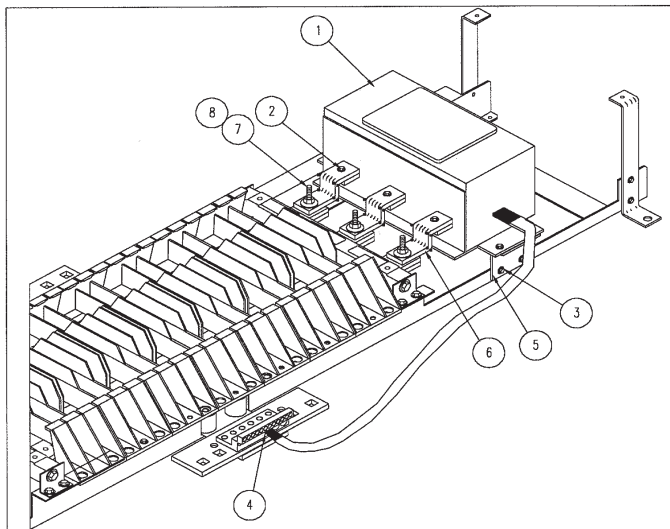

Table 4: CONTENTS for installation in 400/600 amp S1/S2 and All SE Panels

Item	Description	Qty.
1	TPS3 (See Page 2, Table 1)	1
2	1/4-20 Hex Head SEMS Assembly	3
3	10-24 Head Thread Forming Screw	6
4	TPS3 Neutral Connection Point	-
5	TPS3 Mounting Bracket	1
6	Phase Connectors	3
7	1/4" Carriage Bolt	3
8	1/4" Belleville Washer Nut	3

Determine the mounting location of the TPS3 in the distribution equipment. If it is to be mounted in the top of the distribution equipment or relocated after installation, internal phase labeling connections must be changed to ensure proper diagnostic board indication.

These modifications should be made prior to installation. If the TPS3 module is field installed in the bottom, or if it is mounted in a factory assembled panelboard, the internal phase label connections are correct as shipped.

Internal Phase Labeling Connections

A single 14 wire ribbon cable is attached to the display pcb. When the ABC phase sequence changes to CBA, the single connector is removed from the normal "ABC" jack and installed in the jack labeled "CBA"

Lock off all power supplying this equipment before working on it. Remove the trim and dead front.

Install the mounting bracket (Item 5) to the base rail as shown in Figure 3 using two (2) of the #10 thread forming screws (item 3).

Position the TPS3 unit on the panel base rail so that the phase tabs are on top of the interior bus and the four mounting holes line up with the two holes in the base rail and the two holes in the mounting bracket.

Attach the TPS3 unit (item 1) to the base rail using four (4) of the #10 slotted hex washer head thread forming screws (item 3) provided as shown in Figure 3.

Fasten unit to the main bus using the phase connectors (item 6). The connectors will be attached to the unit with three (3) 1/4" hex head SEMS assemblies (item 2) provided. Then they will be connected to the interior with three (3) 1/4" carriage bolts and three (3) Belleville washer nuts (items 7 & 8). Do not tighten at this time.

Fasten TPS3 neutral to panel neutral at the neutral connection point (item 4).

Torque all connections to the values as specified on the installation and maintenance instruction label affixed to the rear of the dead front.

Replace deadfront and trim.

UL 1283 required language concerning the installation of EMI Filters

- a) An insulated grounding conductor that is identical in size and insulation material and thickness to the grounded and ungrounded circuit supply conductors, except that it is green with or without one or more yellow stripes, is to be installed as part of the circuit that supplies the filter. Reference should be made to Table 250-122 of the National Electrical Code regarding the appropriate size of the grounding conductor.
- b) The grounding conductor mentioned in item a is to be grounded to earth at the service equipment or other acceptable building earth ground such as the building frame in the case of a high-rise steel-frame structure.
- c) Any attachment-plug receptacles in the vicinity of the filter are to be of a grounding type, and the grounding conductors serving these receptacles are to be connected to earth ground at the service equipment or other acceptable building earth ground such as the building frame in the case of a high-rise steel-frame structure.
- d) Pressure terminal or pressure splicing connectors and soldering lugs used in the installation of the filter shall be identified as being suitable for the material of the conductors. Conductors of dissimilar metals shall not be intermixed in a terminal or splicing connector where physical contact occurs between dissimilar conductors unless the device is identified for the purpose and conditions of use.

Additional instructions for TPS3 01 & L1 SPDs including:

W option Suffix:

The W option includes repositioned phase connection tabs that allow for wire connections to a circuit breaker within the panelboard. This differs from non-W models, which bolts directly to bus bars.

The circuit breaker serves as a disconnect device and overcurrent protection to the connecting conductors. The TPS3 SPD includes internal overcurrent and overtemperature protective equipment. The breaker does not provide overcurrent protection to the SPD.

Recommended breaker and conductor size is 60A with a 6 AWG conductors. Other combinations are possible. Terminal lugs will accept 2-14 AWG. Breaker size should be at least 20A. All applicable codes must be followed.

Circuit breaker **MUST** be located immediately adjacent to SPD to minimize lead lengths. Move or adjust breaker positions as appropriate. Every effort must be taken to reduce lead lengths. Failure to install short leads will degrade SPD performance.

Install appropriate circuit breaker in panelboard.

Prior to installing SPD, rotate and tighten lug terminals toward breaker location.

Mount the SPD using supplied hardware.

Connect the neutral connection by wire or bracket as appropriate.

Install conductors, short and straight as possible. Use gentle radius on any bends. Do not kink wires. Prevent wires from encroaching breaker locations.

Torque all connections to the values specified on the installation and maintenance instruction label affixed to the rear of the dead front.

Replace dead front supports and trim.

Energize breaker and confirm proper SPD operation.

CAUTION

CONDUCTING DIELECTRIC AND/OR HI-POTENTIAL TESTING WILL CAUSE INTERNAL DAMAGE TO TPS3 UNIT.

Do not perform dielectric or high potential tests with the TPS3 unit installed.

DANGER

Hazardous voltage. Will cause death or serious injury.

Keep Out.
Qualified personnel only.
Disconnect and lock off all power before working on this equipment.

TPS3 05 and TPS3 06 Module Replacement Instructions

The following instructions are for the replacement of Siemens TPS3 SPD module in Siemens TPS3 05 unit.

Figure 5: P4, P5 AND Front Connected Distribution Switchboards

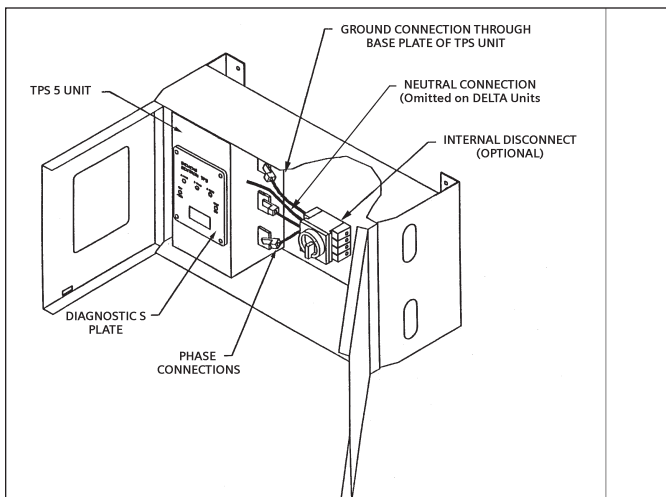

NOTE: TPS3 05 unit may be replaced only if supplied with an internal disconnect.

- Lock off all power supplying this equipment before working on it.
- Open unit door and turn the internal disconnect to the off position.
- Remove the neutral lug wire from the disconnect switch.
- Remove the phase lug wires from the TPS3 05 unit.
- Remove the TPS3 05 unit and discard properly.
- Replace unit with the new TPS3 05 unit.
- Attach the phase lug wires to the correct phase on the TPS3 unit.
- Attach the neutral wire back to the disconnect switch.
- Torque all connections to the values as specified on the installation and maintenance instruction label affixed to the rear of the dead front.
- Do not over torque disconnect switch connections as they will fail.
- Turn the internal disconnect back to the on position.
- Close unit doors before reenergizing.

The following instructions are for the replacement of Siemens TPS3 SPD module in Siemens TPS3 06 unit.

Figure 6: Service Section Switchboards and low voltage Switchgear

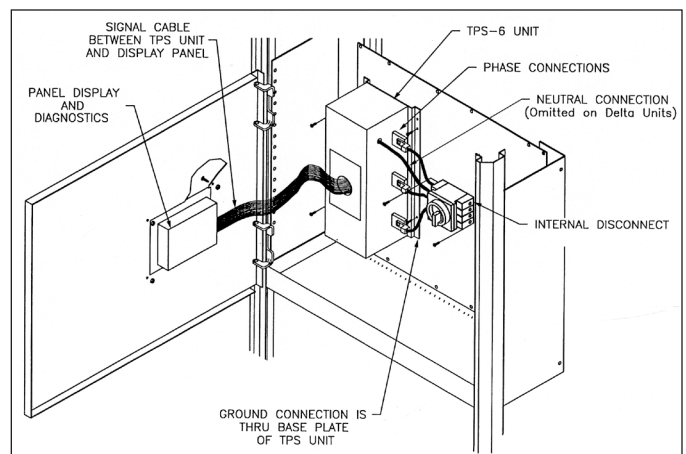

NOTE: TPS3 06 unit may be replaced only if supplied with an internal disconnect.

- Lock off all power supplying this equipment before working on it.
- Open unit door and turn the internal disconnect to the off position.
- Remove the neutral lug wire from the disconnect switch.
- Remove the phase wires from the TPS3 06 unit lugs.
- Remove the TPS3 06 unit with the panel and diagnostics display and discard properly.
- Replace units with the new TPS3 06 units.
- Attach the phase lug wires to the correct phase on the TPS3 06 unit.
- Attach the neutral wire back to the disconnect switch.
- Torque all connections to the values as specified on the installation and maintenance instruction label affixed to the rear of the dead front.
- Do not over torque disconnect switch connections as they will fail.
- Turn the internal disconnect back to the on position.
- Close unit doors before reenergizing.

CAUTION

CONDUCTING DIELECTRIC AND/OR HI-POTENTIAL TESTING WILL CAUSE INTERNAL DAMAGE TO TPS3 UNIT.

Do not perform dielectric or high potential tests with the TPS3 unit installed.

DANGER

Hazardous voltage. Will cause death or serious injury.

Keep Out.
Qualified personnel only.
Disconnect and lock off all power before working on this equipment.

TPS3 01 and TPS3 06 Module Installation Instructions: MCC

Figure 7: Installation in a MCC

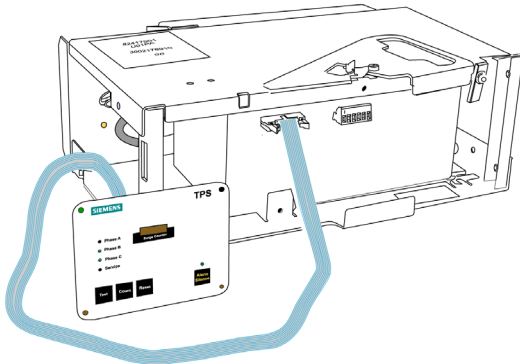

The following instructions are for the replacement of Siemens TPS3 SPD module in a TIASTAR MCC.

This unit is intended for custom factory installation during MCC manufacture. Unit must be removed from the MCC or withdrawn to the TEST position. Familiarize with the TPS and MCC mounting hardware-mount in gear such that the leads are as short and straight as possible without distorting the stab assembly. Failure to do so will result in decreased performance.

Diagnostic Display Connected via Ribbon Cable – to be mounted in a suitable location such that the display is visible to user and/or protected via an access door.

A successful installation includes:

- Meets all national and local codes
- Mount TPS as close as possible to electrical connection
- Ensure leads are as short and straight as possible
- Gently twist or tie-wrap conductors together wherever possible
- Ensure that N-G bonding hazard warning label is attached to TPS as reminder to installing contractor.

Ensure all power is off and unit is deenergized.

Verify that TPS and intended voltage are correct.

Install #6 conductor leads to phase, neutral and ground connections.

Mount Diagnostic Display at appropriate location

Connect ribbon cables from Diagnostic Display to circuit board on Main TPS Backplane Assembly.

Connect to the Dry Contact terminal block if appropriate

Before bench testing –

- Ensure test voltage is appropriate and grounded Wye system – Failure to ensure reference to ground will fail unit.
- Ensure unit is touch safe and that all appropriate enclosures are secure
- Do not Hi-Pot test SPDs
- Do not bench test using ungrounded system – must be grounded Wye system

Confirm that all LEDs are green and that touchpads on display operate correctly.

Operation

TPS3 surge protective devices require minimal attention after installation. TPS3's contain diagnostic circuits which monitor the suppressor's status continuously and automatically. All phase indicators and controls are located on the display panel of the unit. Display panels are formatted either for horizontal or for vertical mounting orientation as required for each application.

TPS3 Control and Diagnostic Display Panel

TPS3's are equipped with a status indicating LED for each phase on the panel. When all LED's are green, the suppressor is on-line and functioning properly. If a fault condition occurs, the audible alarm will sound, the Red Service LED will illuminate and the LED representing the affected phase will extinguish, indicating that the unit needs service. The audible alarm can be silenced by pressing ALARM SILENCE on the touchpad. The audible alarm and Dry Contact can be tested by depressing TEST. If a fault alarm occurs, see Corrective Maintenance (Testing and Repair) for further information.

Display Panel with Surge Counter Option

The surge counter option provides a means to display the total number of transient voltage surge events since the counter was last reset. The counter includes Eprom memory, which retains counter memory in the event of a power loss. The RESET touchpad will reset the counter to zero. The COUNT touchpad increments the counter by one (1) and tests the circuitry for proper operation. If a fault alarm does occur, see Corrective Maintenance (Testing and Repair) for further information.

Figure 8: DISPLAY - HORIZONTAL (SHOWN WITH SURGE COUNTER)

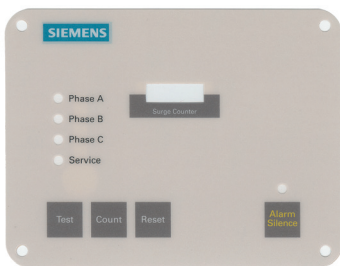
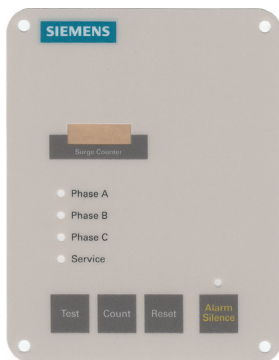

Figure 9: DISPLAY - VERTICAL (SHOWN WITH SURGE COUNTER)



Phase A, B & C: Green LED indicators—one per phase. Green is good. Extinguished green LED indicates loss of protection. Every suppression element in this SPD is monitored. N-G suppression element monitoring is logic-connected to Phase A.

Service LED (red): LED illuminates in the event of problems. This indicator is logic-connected to the Phase LEDs. Should a Phase LED go out, the Service LED will illuminate and the Audible Alarm will sound.

Test: Tests red Service LED and Audible Alarm, and changes state of Dry Contacts

Alarm Silence: Turns Audible Alarm off. (Alarm is deactivated when the Silence LED is illuminated.)

Surge Counter Count: (if equipped) Increments optional surge counter by one (+1)

Surge Counter Reset: (if equipped) Resets optional surge counter to zero (0)

Dry Contacts Feature

TPS3 01, 05, and 06 units are equipped with dry contacts. This feature provides Normally Open (N.O.) and Normally Closed (N.C.) circuits, which can be used for remote indication of a failed transient voltage surge suppressor. There is only one dry contact output consisting of two electrically isolated sets of NC-C-NO contacts. This dry contact output changes from "normal" to "alarm" if any problem occurs inside the SPD (i.e.: loss of power to any phase, any thermal protector inside the SPD opens, or any fuse inside the SPD opens). The dry contact terminal block is located on the back of the module, opposite side of bus tabs. This connector is designed for low voltage or control signals only. Maximum voltage should not exceed 240 volts and maximum current should not exceed 5 amperes. These contacts may be used to provide a signal to an emergency management system or computer interface board. The relay contact pin arrangement is outlined in the table below.

The Normally Closed (N.C.) configuration is recommended because it will detect a wiring defect, such as a cut wire(s), where Normally Open (N.O.) will not.

Figure 10: DRY CONTACT CONNECTION CONFIGURATION

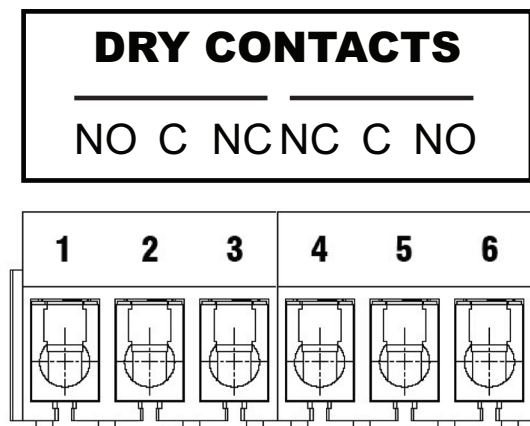

 <h1 style="margin: 0;">CAUTION</h1>
<p>CONDUCTING DIELECTRIC AND/OR HI-POTENTIAL TESTING WILL CAUSE INTERNAL DAMAGE TO TPS3 UNIT.</p> <p>Do not perform dielectric or high potential tests with the TPS3 unit installed.</p>

	 <h1 style="margin: 0;">DANGER</h1>
<p>Hazardous voltage. Will cause death or serious injury. Keep Out. Qualified personnel only. Disconnect and lock off all power before working on this equipment.</p>	

Maintenance

SPDs require minimal maintenance. Periodic inspection of diagnostic LED indicators ensures proper operation. Clean SPD as appropriate.

Troubleshooting & Service

Please contact TPS Technical Support at 1.888.333.3545 for service related issues.

Quality SPDs are designed and tested to withstand severe duty. However, there are various electrical anomalies against which SPDs cannot protect. These are generally Sustained Overvoltages also known as Temporary Overvoltages (TOVs). In this context, Sustained Overvoltages may be only a few cycles. Failed SPDs tend to be symptoms, not root causes. There may be larger issues at play. Regardless of cause, SPDs attempt to protect their load until failure.

Bonding or reference to ground problems are the root cause of many SPD problems. If the SPD shows problems on startup, there is reasonable chance of bonding/grounding/misapplication issue. Such problems permanently damage the SPD. If not corrected, SPD problems will reoccur.

Tip: Visually confirm N-G bonding. Be aware that a voltmeter measuring N-G can be misleading. For example, N-G voltage could read 0V because neutral and ground are at the same potential purely by happenstance, not because they are bonded. Visually confirm bonding.

Tip: Experience indicates that regulation-challenged generators can cause Sustained Overvoltages, as well as ungrounded generators, and/or usual load transfer systems.

Abnormal N-G Voltage Indicators

This SPD include N-G voltage indicators. If the SPD detects excessive N-G voltage, the Red Service LED will blink and the Audible Alarm will cycle. This condition requires immediate attention as the SPD will fail.

Incorrectly bonded distribution systems damage SPDs. If the XO or N-G bonding jumper is not installed, the electrical system has no reference to ground. It becomes an ungrounded system. Please see previous section regarding SPDs on ungrounded systems. Such systems are known to eventually produce abnormally high L-G voltages. SPDs will attempt to chase this system-level overvoltage abnormality until the SPD fails. This effect is accelerated on Wye systems where SPDs are designed for grounded systems. (SPDs for ungrounded systems generally have higher MCOV to allow for L-G voltage fluctuations.) Failures of this nature are not defects in the SPDs workmanship or material. This is an installation error and is not covered by warranty.

A differential voltage circuit monitors neutral to ground voltage. When N-G voltage becomes excessive, an amplifier energizes a resistor. Eventually, that resistor will overheat and cause thermally sensitive shrink wrap to shrink around the resistor. This does not occur on transient or instantaneous N-G overvoltages. When the SPD is deenergized, the shrink wrap covered resistor can be accessed by qualified personnel under the display plate cover.

Module Replacement & Service

The module is field replaceable. Service should only be performed by qualified persons. Deenergize SPD, confirm with appropriate measurement equipment and discharge internal capacitance to ground. Mark locations and carefully disconnect diagnostic cables, contacts, connecting conductors, etc. Unbolt module from backplane. Reinstall in reverse.

There are no user serviceable parts inside the module. Disassembly is not permitted.

Modules may be returned to the factory for factory service, qualification and return. Please contact factory at 1.888.333.3545 for assistance.

Display Replacement

The display is field replaceable. Service should only be performed by qualified persons. Deenergize SPD, confirm with appropriate measurement equipment and discharge internal capacitance to ground. Mark locations and carefully disconnect diagnostic cables, contacts, connecting conductors, etc. Unbolt display and replace. Reinstall in reverse.

Note that a sealing gasket between the display and the enclosure is a key component ensuring weather resistance. Replace the gasket whenever the display is removed.

Preventive Maintenance (Inspection and Testing)

Inspection of the TPS3 SPD unit should be performed periodically, to maintain reliable system performance and continued transient voltage surge protection. The large variations in operating conditions encountered by units in the field make it difficult to set a fixed maintenance interval, but inspections utilizing the built-in diagnostics should be performed at least on a weekly or monthly basis.

Corrective Maintenance (Repair)

The Siemens TPS3 unit is designed for years of reliable, trouble-free operation. Unfortunately, in an extreme case, you may experience an alarm condition. In this event, no attempt should be made to repair the TPS3 itself. There are no serviceable parts within the unit. Any SPD that requires service should be appropriately removed from the electrical distribution equipment, and replaced by a new SPD of the same model.

Technical Support

1.888.333.3545

Prior to calling Siemens TPS3 Technical Support for assistance or ordering parts, please have the following information available:

TPS3 model number: _____

Manufacture date: _____

Date of Purchase: _____

Your order number: _____

Return Shipment Address:

Siemens - Attn: RA # _____

14550 58th Street North

Clearwater, FL 33760

Siemens Industry, Inc.
5400 Triangle Parkway
Norcross, GA 30092
888-333-3545
info.us@siemens.com

