

**LiNC-Ez iAM™**  
Programming Manual  
33-10038-001  
REV: H

FOR **iAM** FIRMWARE VERSION GREATER THAN 4.00.00  
FOR **IQX** FIRMWARE VERSION GREATER THAN 2.00.00  
FOR **NRX** FIRMWARE VERSION GREATER THAN 3.00.00

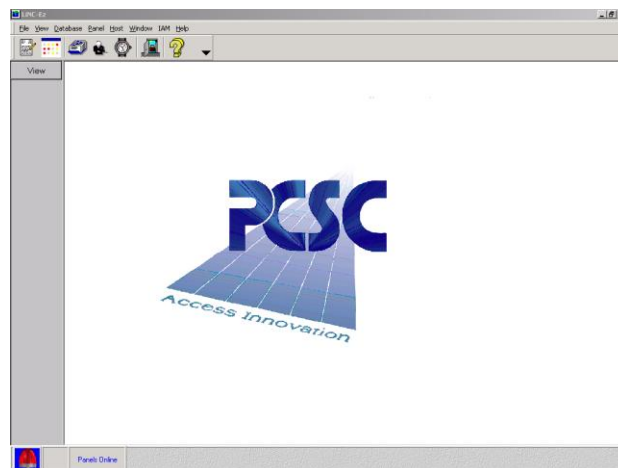

**PCSC**  
**3541 Challenger St.**  
**Torrance, CA 90503**  
**Phone: (310) 303-3600**  
**FAX: (310) 303-3600**  
**[www.1pcsc.com](http://www.1pcsc.com)**

**Publication No. 33-10038-001-H**

First Edition- Revision A: January 2001

Revision B: Dec 2001

Revision C: March 2002

Revision D: October 2002

Revision E: January 2003

Revision F: April 2003

Revision G: December 2005

Revision H: July 2006

Information in this manual is subject to change without notice and does not represent a commitment on the part of PCSC. The software described in this manual is furnished under a license agreement or nondisclosure agreement. The software may be used or copied only in accordance with the terms of the agreement. No part of this document may be reproduced, or transmitted, in any form or by any means, electronic or mechanical, including photocopying, recording, or information storage and retrieval systems, for any purpose other than specified in the agreement, without the express written permission of PCSC.

*Windows* is a registered trademark of the Microsoft Corporation.

© 2006 PCSC. All Rights Reserved.

Printed in the United States of America.

Published by **PCSC**  
3541 Challenger Street  
Torrance, CA 90503  
Phone: (310) 303-3600  
FAX: (310) 303-3600  
**Publication No. 33-10038-001-H**

## 0.1 Release Notes for LincEz iAM v2.1.48

### 0.1.1 Important Compatibility Operation:

**LincEZ iAM** Software is compatible with **iAM v4.00.00** and newer versions. All PANELS or IQX reference in this Installation Manual and on LincEZ iAM screen operations applies to all iAM Controllers; unless otherwise indicated.

**\*\*WARNING\*\*** OLD LiNC-Ez iAM VERSIONS (1.xx.xx) ARE NOT COMPATIBLE WITH NEW IQX FIRMWARE. (2.xx.xx) UPGRADE LiNC-Ez SOFTWARE WHEN A NEW IQX OR NRX IS INSTALLED.

**\*\*WARNING\*\*** LiNC-Ez IAM IS NOT COMPATIBLE WITH IQX VERSIONS LESS THAN 2.00.00. YOU MUST UPGRADE OLD IQX FIRMWARE WHEN USING LiNC-Ez II. FOLLOW IQX DOWNLOAD INSTRUCTION LOCATED IN ALL ORIGINAL LiNC-Ez CD.

### 0.1.2 Release Notes from LincEZ v2.1.48 to LincEZ v2.2.34

iAM control features were added to **LiNC-EZ iAM Menu** and **Card Manager**.

The **Zone**, **ZoneGroup**, and **Central Station Configuration** were added to **Menu**. Alarm **Control** was added to each card in **Card Manager**

IOX control features were added to **LiNC-EZ iAM Menu**.

**Input Configuration**, **Status** and **Calibration** were added to menu.

**Single Client** feature was added to **Company Info**.

Complete **Remote Programming** and reporting communication can be establish via **Client**.

Remote access via **Terminal Server** to RS485.

Communication via **RS485 Terminal Server** for complete remote TCP/IP to Panel RS485 Loop.

Four **Auto Unlock Time Periods** added for flexible time period unlock.

Allows different weekly day unlock schedule.

Repaired **International Date Format** operation.

Day-Month-Year date format operate on all date screens.

**Broadcast** will not operate on Panel firmware x.00.77 or earlier.

**Broadcast** works only on **iAM** v4.01.14, **NRX** v3.00.80, **IQX** v2.00.80 and/or **IOX** v5.00.08; or newer.

Only single **iAM** will communicate via RS232 LapLink Cable.

Any combination of **iAM**, **NRX**, **IQX** or **IOX** requires RS485 communication.

## 0.2 Table of Contents

<b>LiNC-Ez iAM™</b> .....	<b>i</b>
0.1 Release Notes for LincEz iAM v2.1.48 .....	iii
0.1.1 Important Compatibility Operation:.....	iii
0.1.2 Release Notes from LincEZ v2.1.48 to LincEZ v2.2.34 .....	iii
0.2 Table of Contents .....	iv
<b>1.0 Introduction</b> .....	<b>1</b>
1.1 PC Requirements - LiNC-Ez iAM™ Software .....	2
1.2 Hardware Requirements .....	2
<b>2.0 Loading LiNC-Ez iAM™</b> .....	<b>3</b>
<b>3.0 LiNC-Ez iAM™ Layout and Features</b> .....	<b>4</b>
3.1 LiNC-Ez™ Menus .....	5
3.1.1 File Menu Selection .....	5
3.1.2 View Menu Selection .....	5
3.1.3 Database Menu Selection .....	6
3.1.4 Panel Menu Selection .....	6
3.1.5 HOST Menu Selection.....	7
3.1.6 Window Menu Selection.....	7
3.1.7 iAM Menu Selection .....	8
3.1.8 HELP Menu Selection .....	8
3.2 LiNC-Ez iAM™ Toolbar .....	9
<b>4.0 LiNC-Ez iAM™ Programming</b> .....	<b>10</b>
4.1 Configuration Wizard .....	10
4.1.1 Company Information .....	10
4.1.2 New/Open Client Feature .....	11
4.1.3 Door Names .....	12
4.1.4 Door Assignments .....	12
4.1.5 Daylight Savings.....	13
4.2 Door Configuration.....	14
4.2.1 Door Properties .....	14
4.2.2 Access Parameters .....	16
4.2.3 Readers .....	18
4.2.3.1 Entry/Exit on a Single Door.....	18
4.2.3.2 Reader Configuration Screen .....	19
4.2.4 Counter Properties .....	20
4.2.5 Configure Aux I/O [ for NRX Only ] .....	20
4.3 Standard Time Periods .....	21
4.4 Holiday Time Periods.....	22
4.5 Holiday List .....	23
4.6 Authorization Groups .....	24
4.7 Card Manager.....	25
4.7.1 Adding Cardholders through the Overview and Detail Tabs .....	25
4.7.2 Alarm PIN User Number.....	27
4.7.3 Using the iAM Panel.....	28
4.7.3.1 How to arm the iAM panel.....	28
4.7.3.2 Bypassing zones .....	29
4.7.3.3 How to Disarm the iAM panel .....	29

4.7.4 Bulk Change .....	30
4.7.5 iAM .....	31
4.7.5.1 Setting an iAM access card PIN code: .....	31
4.7.5.2 Establishing an Alarm Company Guard Card.....	32
4.7.5.3 iAM Zone Configuration .....	32
4.7.5.4 Creating Zone Groups .....	33
4.7.5.5 Calibrate or Suppress Alarm Zones.....	33
4.7.5.6 Central Station Configuration.....	34
4.8 Import and Export .....	35
4.8.1 Import .....	35
4.8.2 Export .....	36
4.9 Download/Broadcast.....	37
4.10 Transaction Monitor .....	38
4.11 Site Codes .....	39
4.12 Generating Reports .....	40
4.13 iAM Security Management.....	41
4.13.1 Configuring Alarm Zones using LiNC-Ez™ .....	41
4.13.2 Setting the Parameters for the Central Station Notification .....	42
4.13.3 Configuring the Zone Groups.....	43
4.13.4 Calibrating a Supervised Alarm Zone .....	44
<b>5.0 LiNC-Ez Communication.....</b>	<b>45</b>
5.1 Single Modem; Multiple Panel (SMMP).....	45
5.1.1 Connecting the Modem .....	46
5.1.2 Panel Loop .....	46
5.2 Modem SMMP Programming.....	47
5.2.1 Computer Configuration .....	48
5.2.2 Modem Configuration .....	49
5.2.3 LiNC-Ez™ Panel Communications .....	50
5.2.4 iAM Modem Communication Setup.....	51
5.3 TCP/IP Communication (Optional LAN/Ethernet).....	52
5.3.1 Local Area Network Installation (IP Address Assignment).....	55
5.3.2 Wide Area Network Installation (IP Address Assignment) .....	55
<b>6.0 Appendix iAM Startup &amp; Default Parameter .....</b>	<b>56</b>
End of Manual .....	57

# 1.0 Introduction

Welcome to the LiNC-Ez iAM™ Installation and User manual. The LiNC-Ez iAM™ access control and alarm system is the best and most cost-effective system on the market for the small to mid-size facilities. This manual will describe the best method for loading LiNC-Ez iAM onto your system and configuring the access control and security measures capabilities. The manual is designed in the following order:

<b>1.0 Introduction.....</b>	<b>1</b>
<b>2.0 Loading LiNC-Ez iAM™ .....</b>	<b>3</b>
<b>3.0 LiNC-Ez iAM™ Layout and Features .....</b>	<b>4</b>
<b>4.0 LiNC-Ez™ Programming .....</b>	<b>10</b>
<b>5.0 Remote Modem Communication Setup (optional).....</b>	<b>45</b>
<b>6.0 Appendix iAM Startup &amp; Default Parameter .....</b>	<b>56</b>

It is assumed that prior to loading LiNC-Ez iAM, the physical layout of the IQX, NRX and iAM, readers and assorted I/O's of the LiNC-Ez iAM system have been determined.

## 1.1 PC Requirements - LiNC-Ez iAM™ Software

To install LiNC-Ez iAM™ for Windows- 2000/XP, the following requirements must be met:

- Windows 2000 or Windows XP must be installed on the host computer.
- User must have knowledge of mouse and keyboard use in the Windows 2000/XP environment.

## 1.2 Hardware Requirements

Compare your computer hardware features to the chart below, which lists the requirements for proper operation of LiNC-Ez iAM™. If you have any questions regarding your computer configuration, call PCSC Application Engineering at (310) 303-3600.

Hardware Item	Minimum Requirements
<b>CPU</b>	IBM PC or equivalent: Pentium (minimum 800 MHz for Host), Windows 2000 or Windows XP.
<b>RAM</b>	256 MB
<b>Hard Drive</b>	8 GB
<b>Diskette Drive</b>	3.5 in., 1.44 MB
<b>CD RW Drive</b>	24X CD RW drive
<b>Monitor</b>	SVGA, 640 x 480, 16 color
<b>Keyboard</b>	AT type
<b>Mouse,</b>	WINDOWS compatible Bus or PS2 Mouse
<b>Parallel Port</b>	LPT1
<b>Serial Port</b>	One DB9 COM RS-232 dedicated for LiNC-Ez iAM™
<b>U.P.S.</b>	Uninterruptible Power Supply 420 VA for PC and monitor

## 2.0 Loading LiNC-Ez iAM™

Close all programs, including those which default to COM1 (i.e. - PDA communication device, Palm Pilot Link, serial mouse, etc.). Also, disable any virus protection software until installation is complete.

Install the LiNC-Ez iAM™ program CD into the CD-RW drive. The InstallShield Wizard should launch automatically once.

**NOTE:** If the CD-ROM doesn't automatically launch, use the following steps to launch the **InstallShield Wizard**.

1. Enter **Windows** to find out what is the letter name of the CD-ROM drive.
2. Click on the **Start Menu** and then select **Run**.
3. Type in the Letter of the CD-ROM drive followed by “:\setup.” Click **OK**. This will start the loading process.

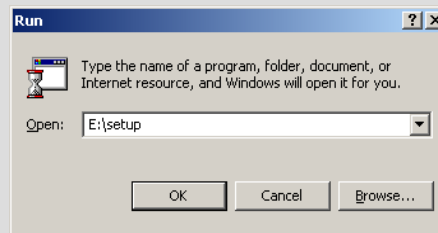

The **InstallShield Wizard** takes over the loading process and will guide you through the rest of the process.

1. Enter your **Name** and **Company Name** and click on **Next**.



2. Check the appropriate language you wish to operate LiNC-Ez iAM™.
3. Install will automatically load the LiNC-Ez iAM™ into the Program Files folder. Redirect if necessary.
4. Click **Finish** to complete the process and restart your computer.





### 3.0 LiNC-Ez iAM™ Layout and Features

Once you have finished the installation process, a LiNC-Ez iAM™ shortcut will be placed on your desktop.

Double-click on the LiNC-Ez iAM™ shortcut. LiNC-Ez iAM™ will open to its main page.

**NOTE:** Section 3.0 is devoted to describing the basic layout of the LiNC-Ez iAM™ program and its different sub-menus. To continue with the programming of LiNC-Ez iAM™, please proceed to Section 4.0.

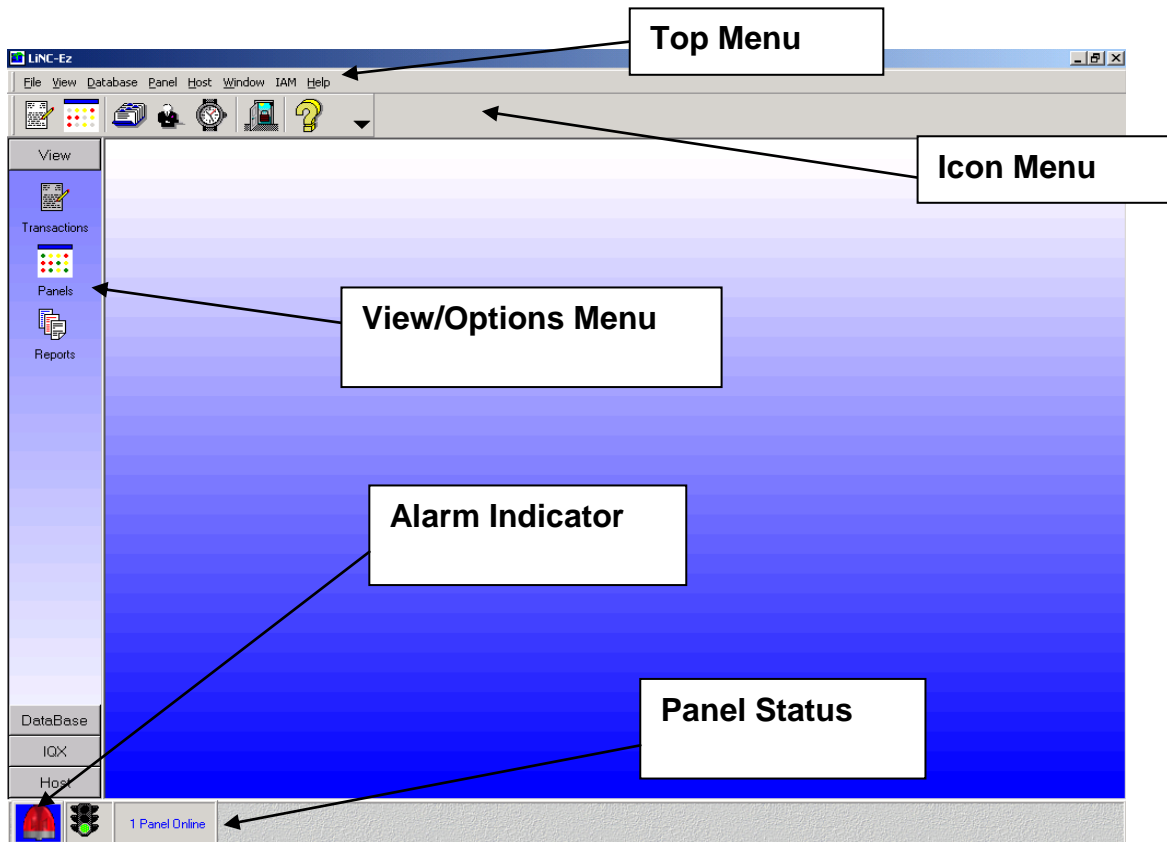

## 3.1 LiNC-Ez™ Menus

### 3.1.1 File Menu Selection

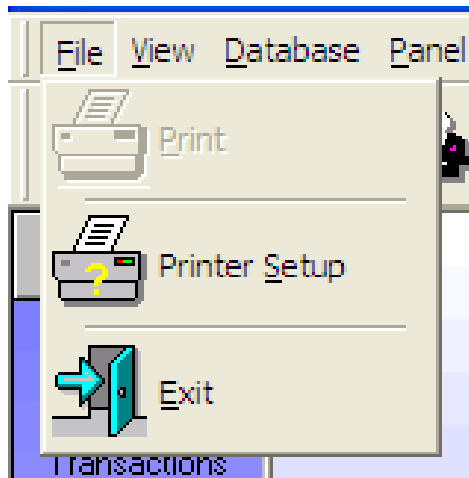

**Print** Prints contents of Transaction Monitor, Reports, Card Manager & Holiday List to the selected printer

**Print Setup** Allows operator to select a printer on the system and control the properties of the printer.

**Exit** Causes LiNC-Ez iAM to cease operating. By doing this you will cause the controllers to operate in a standalone mode until the program is restarted.

### 3.1.2 View Menu Selection

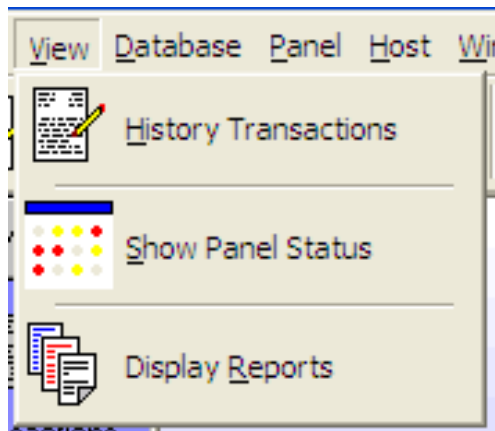

**History Transactions** Allows the operator to view all transactions as they are received from the panels.

**Show Panel Status** View status of all panels & Door Lock Status on the system.

**Display Reports** Predefined reports available to the operator:

- Card Holder Report
- Holiday List
- Holiday Time Period
- Standard Time Period
- History Log

### 3.1.3 Database Menu Selection

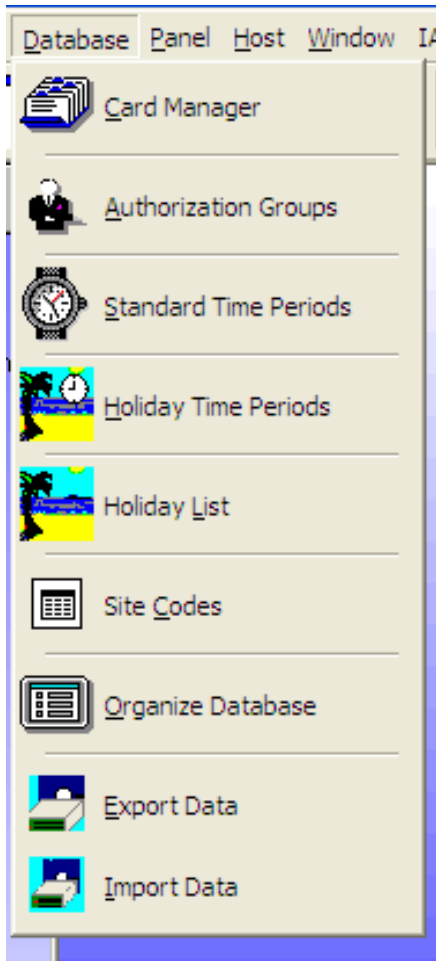

**Card Manager** Add/Delete/Change cards in the database [ 1-3,000 Card Capacity].

**Authorization Groups** Displays all authorization groups and allows operator to View/ Change/ Add/ Delete groups.[1-255 Authorization Groups]

**Standard Time Periods** View/Change/Add standard time periods. [1-32 Time Periods].

**Holiday Time Periods** View/Change/Add holiday time periods [1-32 Holiday Time Period].

**Holiday List** Displays the entered holiday list [Up to 64 Holidays].

**Site Codes** Ability to View/Change site codes [1-16 Site Codes].

**Organize Database** Optimizes and repairs database.

**Export Data** Allows an administrator to export the current LiNC-Ez parameters.

**Import Data** Allows an administrator to import the current LiNC-Ez parameters.

### 3.1.4 Panel Menu Selection

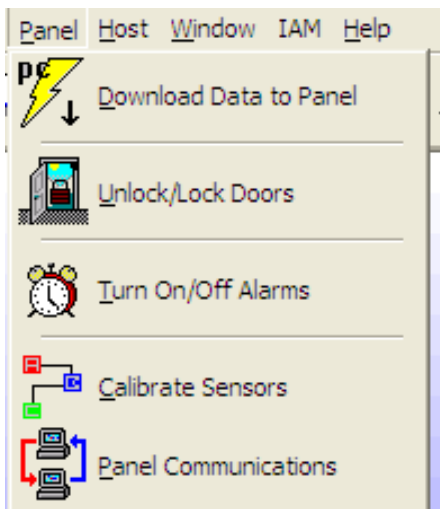

**Download Data to the IQ** Initiate a download of parameters to the panels

**Unlock/Lock Door(s)** Enables operator to unlock or lock a specific door.

**Turn On/Off Alarm(s)** Enables/ disables alarms

**Calibrate Sensors** Calibrates all supervised circuits.

**Panel Communications**  
Ability to change and set communication via serial RS-232 (COM), modem (dial-up phone line) or TCP/IP (LAN or Ethernet).

### 3.1.5 HOST Menu Selection

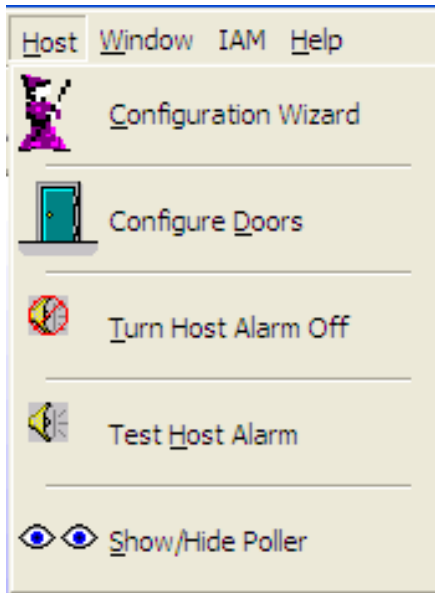

**Configuration Wizard** Sets up company information, Door Names, Door Assignments and Daylight Savings times.

**Configure Doors** View/change Door Properties, Access Parameters and Readers.

**Turn Host Alarm Off** Toggles the alarm On/Off.

**Test Host Alarm** Tests the alarm on the system.

**Show/Hide Poller** Turns poller information in LiNC-Ez iAM task bar on/off.

### 3.1.6 Window Menu Selection

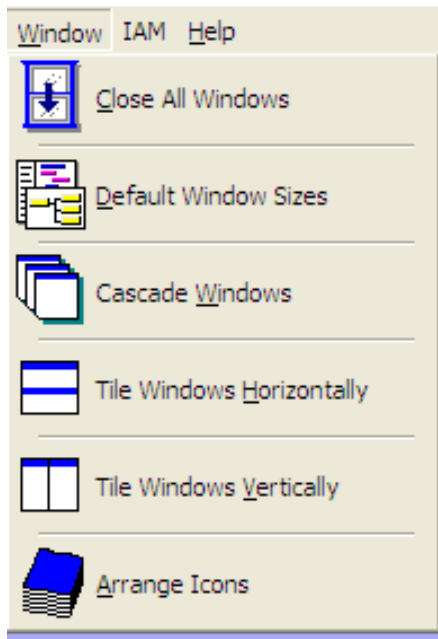

**Close All Windows** Closes all windows previously opened.

**Reset Default Sizes** Restores all windows to default sizes.

**Cascade** Arranges selected windows in a cascaded orientation.

**Tile Horizontally** Arranges selected windows one above the other.

**Tile Vertically** Sets up selected windows side by side.

### 3.1.7 iAM Menu Selection

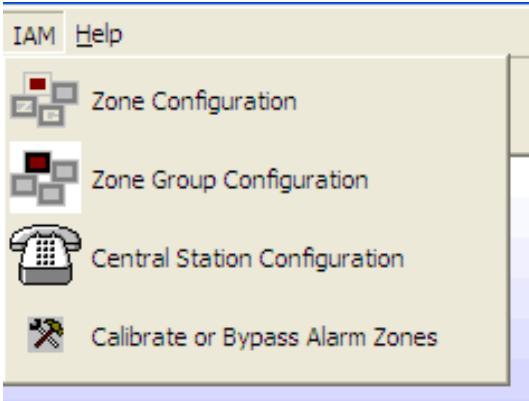

**Zone Configuration** Sets Alarm Zones parameters, Zone Names, Supervised Zones, Latched Alarm points, Bypass zone point, Common Area Armed Override and Zone Delay period.

**Zone Group Configuration** Creates definition of each Zone Group.

**Central Station Configuration** Sets the parameters for contacting the Central Station.

**Calibrate or Bypass Alarm Zones** Allows the user the ability to calibrate or bypass individual alarm zones.

### 3.1.8 HELP Menu Selection

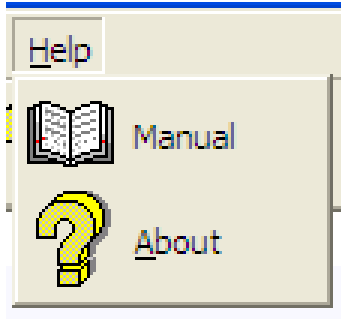

**Manual** Opens a pdf version of this manual.

**About** Provides information about Author and Version of the program.

### 3.2 LiNC-Ez iAM™ Toolbar

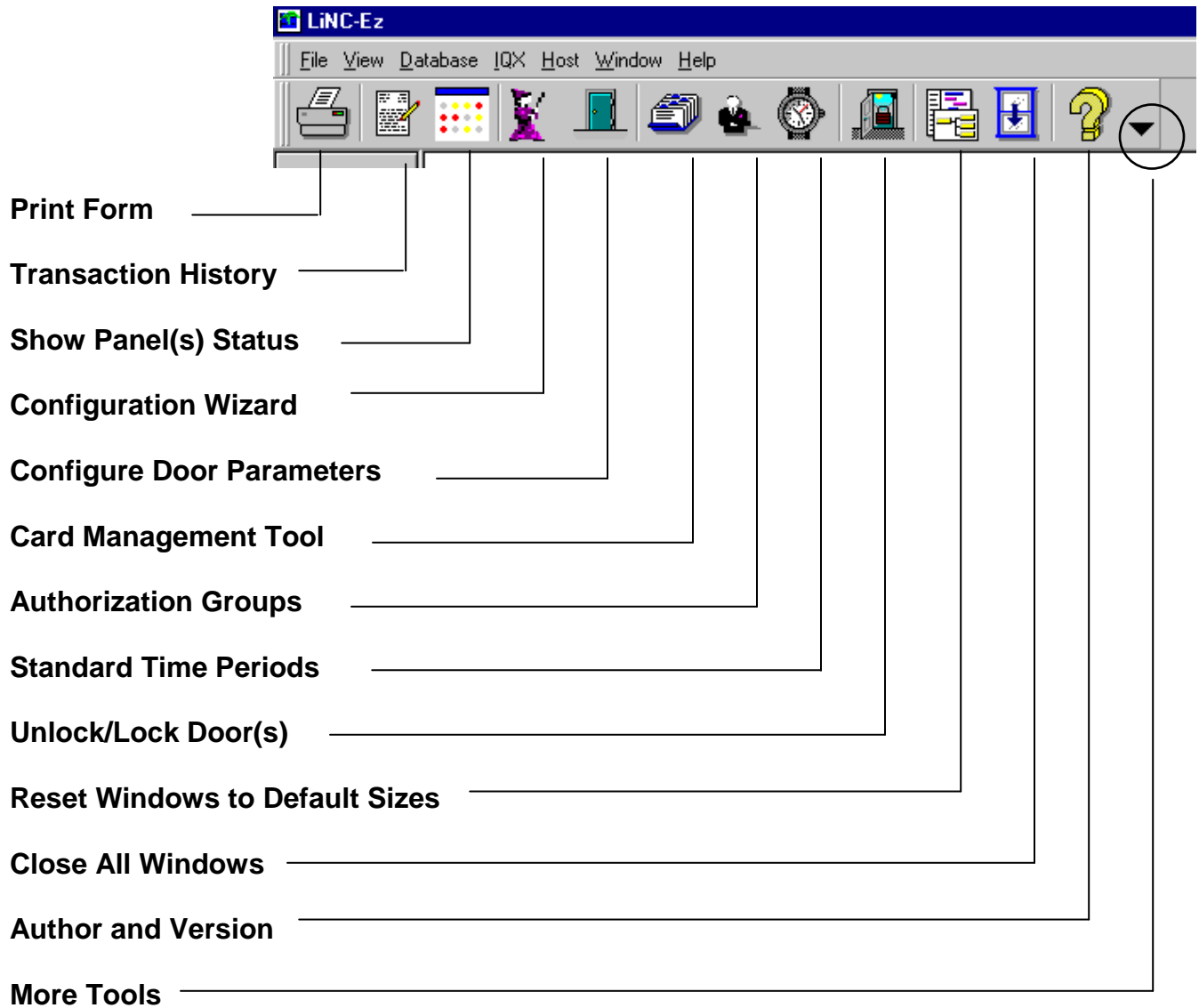

## 4.0 LiNC-Ez iAM™ Programming



### 4.1 Configuration Wizard

Once the initial loading of LiNC-Ez iAM™ is complete, the LiNC-Ez iAM Configuration Wizard will determine the communication method and basic operating setup, will download the default database to run with the default data. Additionally, it will reference the reader to where to jump to initiate a full data download.

#### 4.1.1 Company Information

1. Enter: **Your Name**  
**Company Name**  
**Address**  
**Phone number**
2. Select **Apply** or **OK**. Select **Clear** to begin over again.
3. The **Regional Setting** will adjust Holiday List for LiNC-Ez iAM™.
4. **Password** will protect from unauthorized access to LiNC-Ez iAM™ Software. Press **Password**, in the password screen type in your password, twice.
5. The next time LiNC-Ez iAM™ is launched, the password will be required. To remove password: follow the same procedure to Add, but enter a blank field.

**Note: Do not forget the password. You can NOT retrieve the password. You must reload LiNC-Ez iAM if the password is lost.**

## 4.1.2 New/Open Client Feature

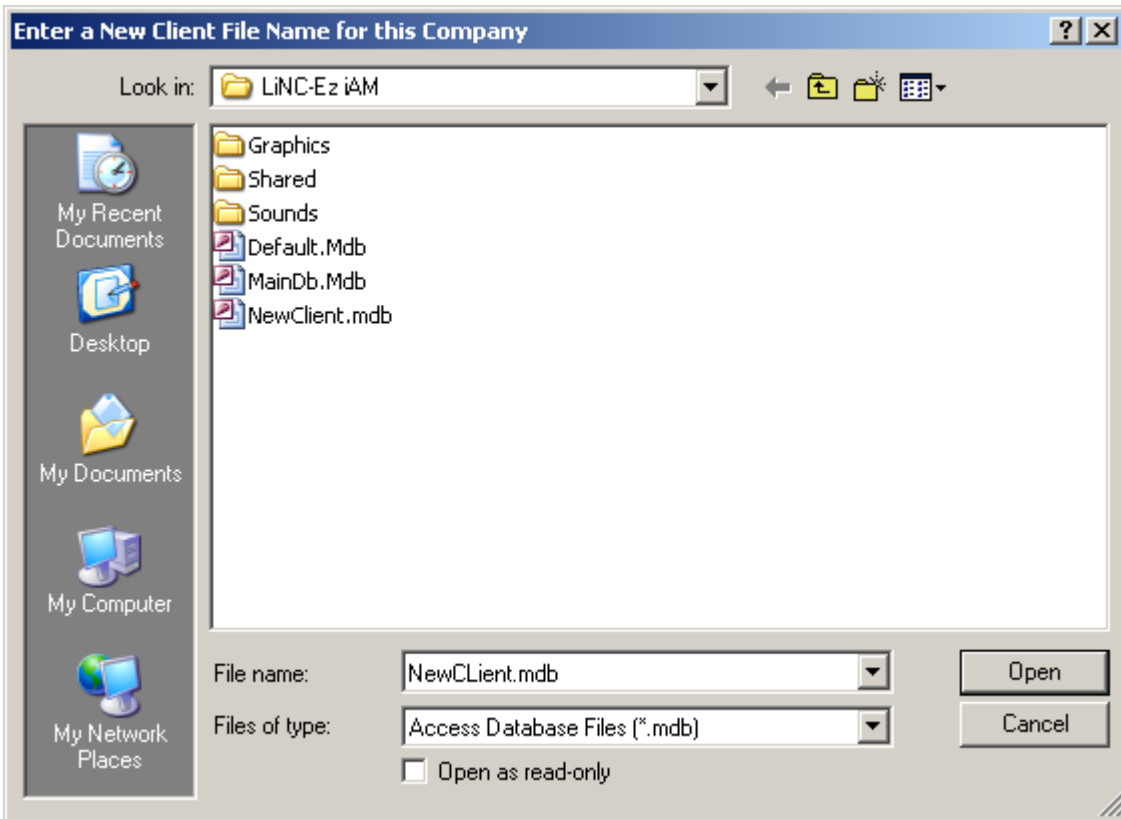

1. To create **New Client**, select **New Client** button at Configuration Wizard.
2. Type the name of the New Client and click **Open**.
3. To open a client, select **Open Client** button at Configuration Wizard.
4. Select the client and click **Open**.

**NOTE:** To change configurations of newly created client, close and reopen LiNC-Ez iAM™. This will default the settings of the software and will be ready to be changed. It is mandatory to close and re-open LiNC-Ez iAM™ whenever switching between clients, for changes to be made to the appropriate client.



### 4.1.3 Door Names

1. Enter the number of panels connected together on this system.

**IMPORTANT** This indicates how many panels to look for.

2. Add or Delete door names as they will be used at this site.
3. Select **Apply**.

This will create the list of selections that will be used on the next screen.

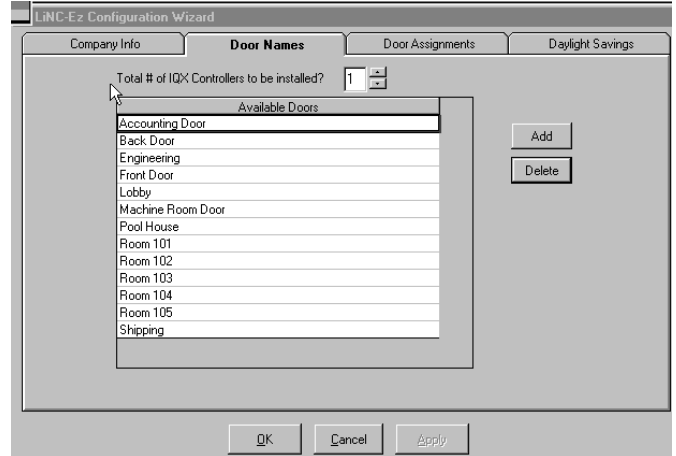

### 4.1.4 Door Assignments

1. For each door on the system, select the name of the door by clicking the down pointer and highlighting the name of the door assigned to each panel.
2. Select **Apply** to store the names.

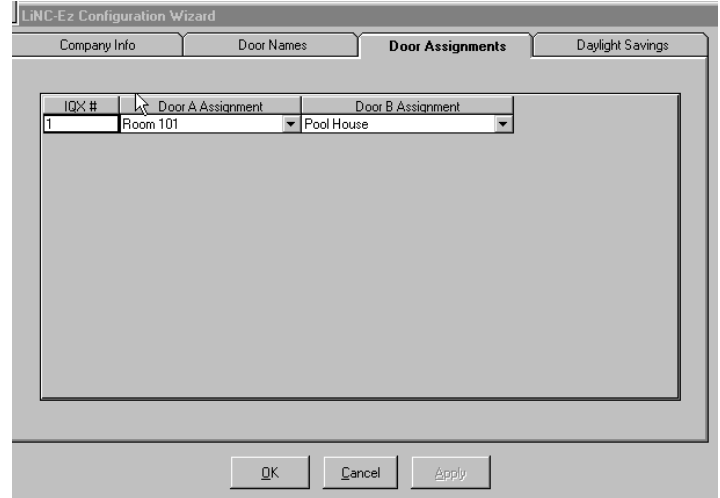

## 4.1.5 Daylight Savings

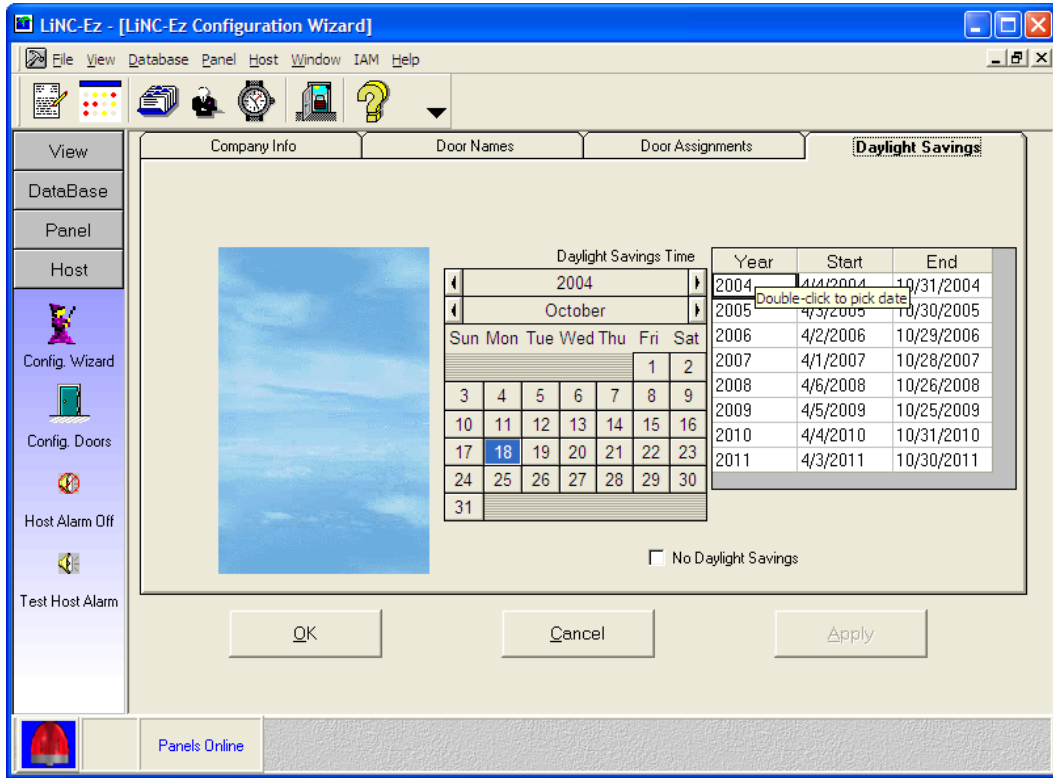

The daylight savings times have been factory set until 2012. To correct or change any of the default dates you can change the **Start** or **End** dates in the **Daylight Savings Time** field.

Setting the **No Daylight Savings** option will cause the program to ignore **Daylight Savings**.



## 4.2 Door Configuration

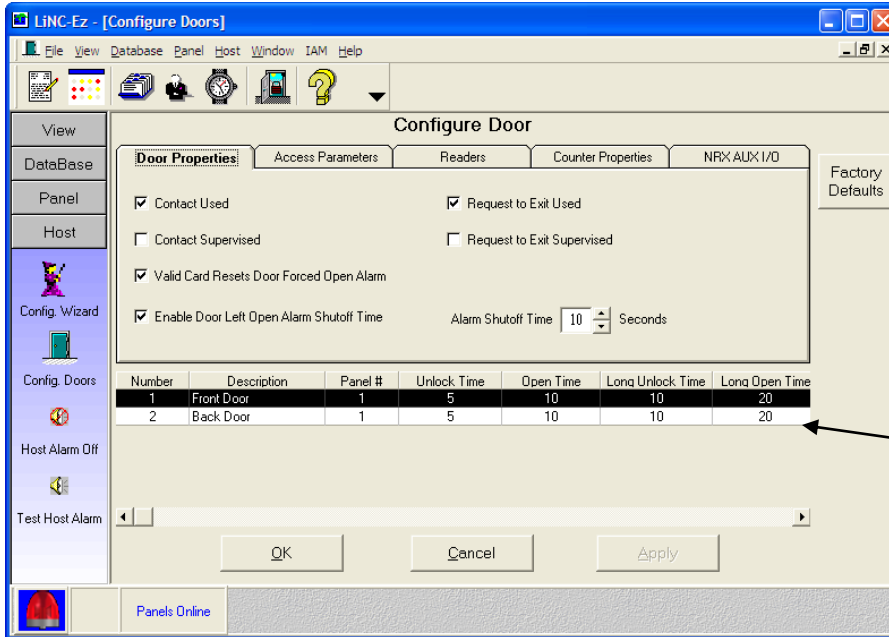

### IMPORTANT:

Select the appropriate panel for all **Configure Door** tabs,.

### 4.2.1 Door Properties

This group of screens sets up the operating parameters for all of the access controlled doors. The factory default set up for doors will show all items selected except **Contact Supervised** and **Request to Exit Supervised**.

Set up the **Door Properties** as follows:

**Contact Used** Check this box if door contacts are to be monitored to audit door open or closed status.

**Contact Supervised** Check if contact circuit is monitored for tampering using 4-state supervision.

**Request to Exit Used** Check box if REX (Request to Exit) has been installed and is to be used to allow for push button opening of a controlled door.

**Request to Exit Supervised** Check box if the REX circuit is monitored for tampering using 4-state supervision.

**Valid Card Resets Door Forced Open Alarm** Check this box if you want any local alarm that is sounded to be turned off by the first valid card that is read after the alarm is triggered.

**Enable Door Left Open Alarm Shutoff Time** Select this box to set up the amount of time that the alarm will be bypassed before sounding.

**Alarm Shutoff Time**

Used to set the amount of time to shunt the alarm when the Enable Alarm Shutoff Time box has been selected.

**Factory Defaults**

Selecting this will cause the program default values to be entered into the door configurations.

## 4.2.2 Access Parameters

The access parameters set up the length of time doors are unlocked and allowed to be open before any action is taken to report alarms.

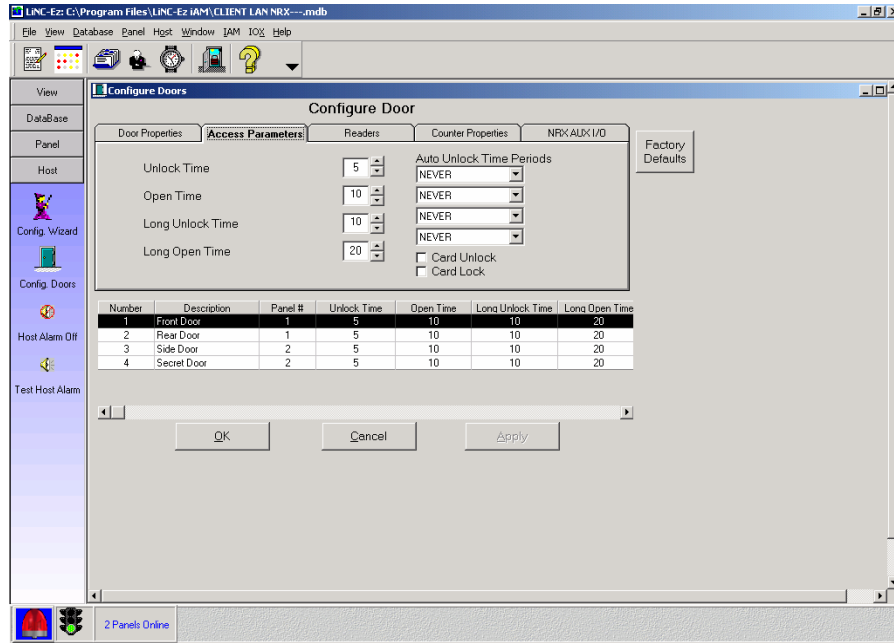

Note: LiNC-Ez-iAM™ software currently offer four Auto Unlock Time Periods. Versions prior to 2.2.34 offer only one Auto Unlock Time Period.

Set up the Access Parameters as follows:

- Unlock Time** The amount of time in seconds that the door lock is energized (door unlocked).
- Open Time** The amount of time that the door can remain open prior to an alarm sounding if an alarm has been selected for this door.
- Long Unlock Time** The amount of time specified for certain cardholders needing extra time to open a door.
- Long Open Time** The amount of extended time that the door will remain open until an alarm is triggered in those cases where additional time is required to get through the door. Maximum setting is 255 seconds.

<b>Auto Unlock Time Period</b>	The duration which a door will automatically unlock. Select the time period by clicking on the down arrow and highlighting the desired time period.
<b>Card Unlock</b>	Auto Unlock Time Period starts when the first Authorized Card is presented during the Auto Unlock Period.
<b>Card Lock</b>	Locks door during AutoUnlock Period when an Authorized Card is presented.

Note: On a Holiday time periods, if Auto Unlock Time Period is programmed, Auto Unlock must always be Authorized with a valid card.

## 4.2.3 Readers

This screen is used to configure each of the readers. LiNC-Ez iAM™ is compatible with a wide range of proximity readers (such as the PR-732 included in the LiNC-Ez iAM™ Installation kit), proximity-keypad readers, and magstripe readers.

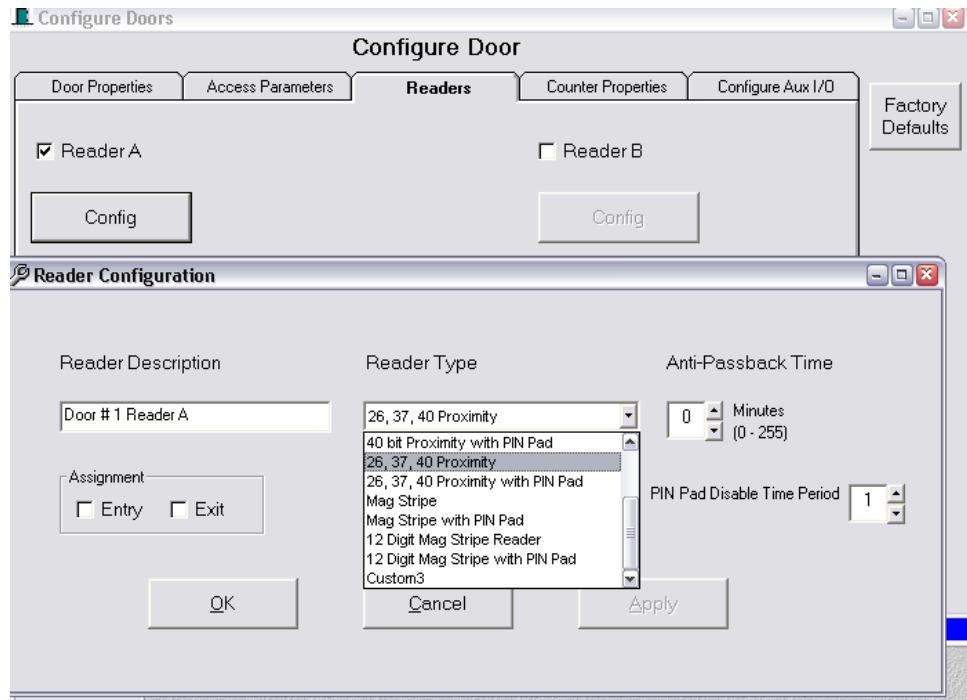

Select the reader by checking the box next to the reader name and press **Config** button to bring up the **Reader Configuration** screen.

### 4.2.3.1 Entry/Exit on a Single Door

LiNC-Ez iAM™ has the ability for entry/exit capability on a single door. By installing readers on either or both sides of an access point, LiNC-Ez iAM™ can be set up to monitor entry and exit from a single room.

In the **Reader Config** screen, in the **Assignment** box, a reader can be set to monitor either **Entry** or **Exit**. In an access point with two readers, **Reader A** may be set for **Entry** and **Reader B** set for **Exit** (or vice versa).

### 4.2.3.2 Reader Configuration Screen

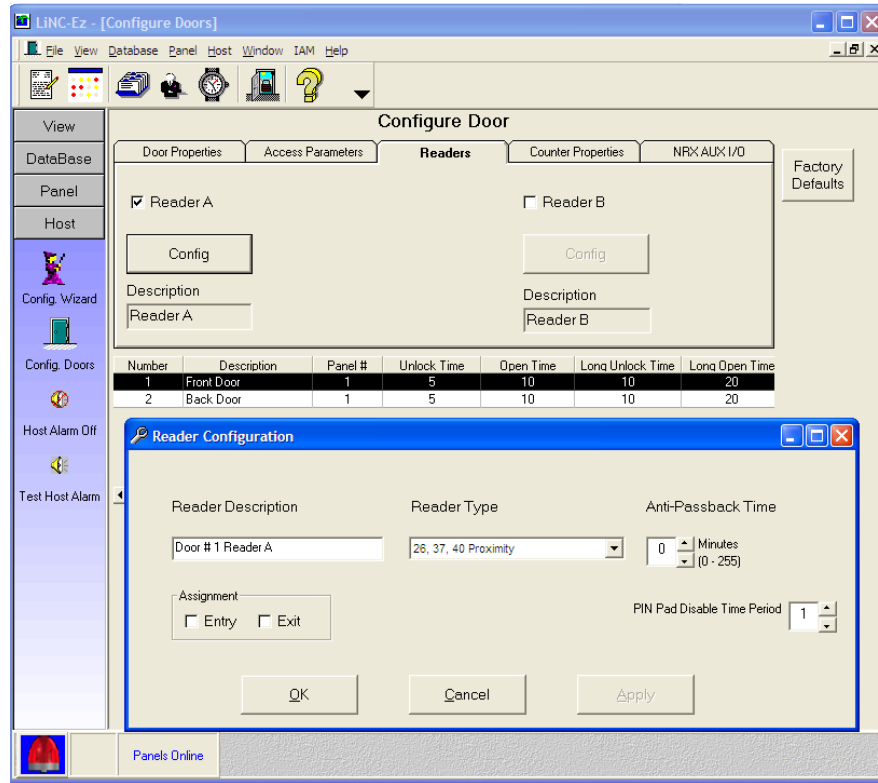

**Reader Description** In this screen you will see the Door # and name assigned to that door.

**Reader Type** Select the down arrow and highlight the reader type being used with this door position on this panel. (This area has been expanded for more reader types.)

**NOTE:** If card is selected with Keypad, all cards will default to 0000 as the pin number.

**Anti-Passback Time** Select the amount of time to pass before a card can be used again at this reader. Select **Apply** or **OK** to activate and save your selections.

**NOTE:** This is to prevent someone from passing his or her card back to another user to allow entry into the door or gate.

**Entry/Exit Assignment** allows access to area controlled by a single panel (two doors) only.

**IMPORTANT:** Inside the Reader Configuration window, the proper door must be highlighted when antipassback is required. This will establish the highlighted door as Entry; the second door of this panel will automatically be the Exit.

The operation of Entry/Exit is when a card is authorized to the Entry reader then it must be authorized to the Exit before entry is granted again.

**NOTE:** Entry/Exit is per one panel only. It is not global within a system of panels. The EXIT will always be granted.



## 4.2.4 Counter Properties

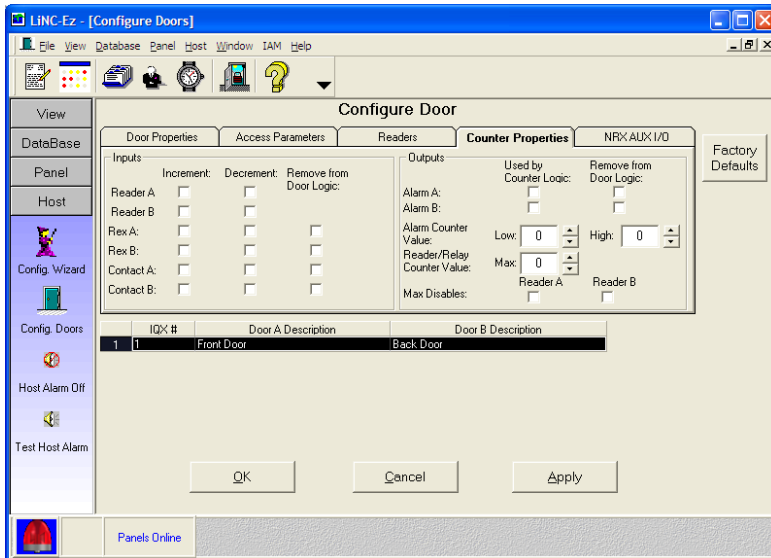

All **Readers, Rex,** and door **Contacts** can be applied to **Increment** or **Decrement** area inputs.

The **High Count** will turn on **Local Alarm**. Maximum count will **DISABLE** door relays.

**NOTE:** Area Counter is controlled by only **one** panel. Each area is controlled one panel, **not** multiple panels.

## 4.2.5 Configure Aux I/O [ for NRX Only ]

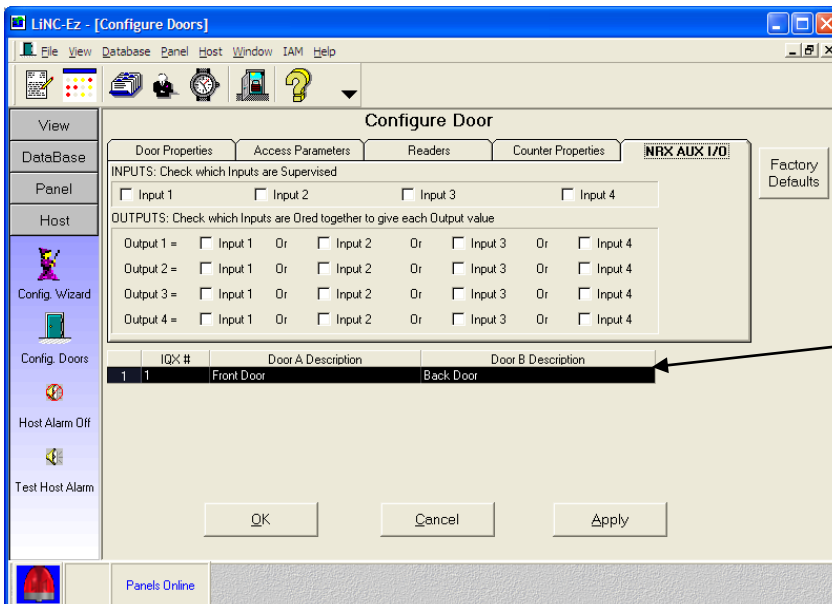

Select the Inputs which are Supervised.

Check which **Inputs** are Ored together to turn **ON Output**.

Select NRX only

## 4.3 Standard Time Periods

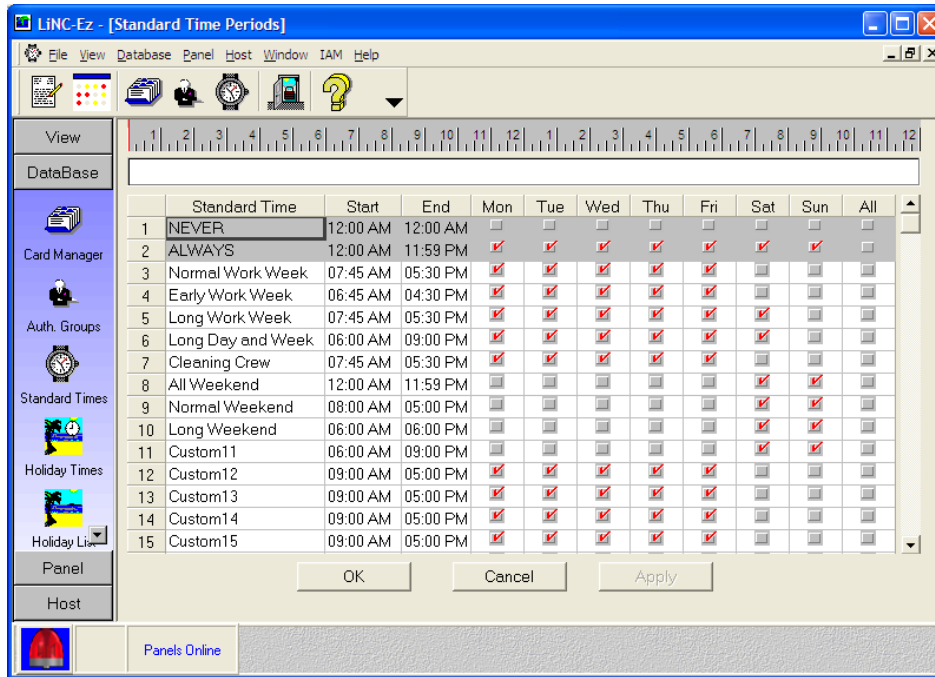

This screen brings up the factory default (i.e. **Standard**) Time Periods. Time Periods are schedules consisting of definable start and end times within different days of the week (Holidays Time Periods are discussed in section 4.4). Each user is associated with one of 32 Standard Time Periods, allowing that person designated periods of access to and within the building.

To change the times within the periods, highlight the Standard Time Period you want to change and:

1. Left-click on the red bar at the top of the screen at either end and adjust its length to your requirements. This will automatically update the Start and End columns as you change the size of the red bar.

OR

2. Double click a Start/End and use the up/down arrows in the box to change the start and end times.

3. Select **Apply** or **OK** to save your data.

**NOTE: NEVER and ALWAYS are factory defaults and cannot be altered.**

## 4.4 Holiday Time Periods



Holiday Time Periods function in the same manner as Standard Time Periods but are active on Holidays only. LiNC-Ez iAM supports up to 32 Holiday Time Periods.

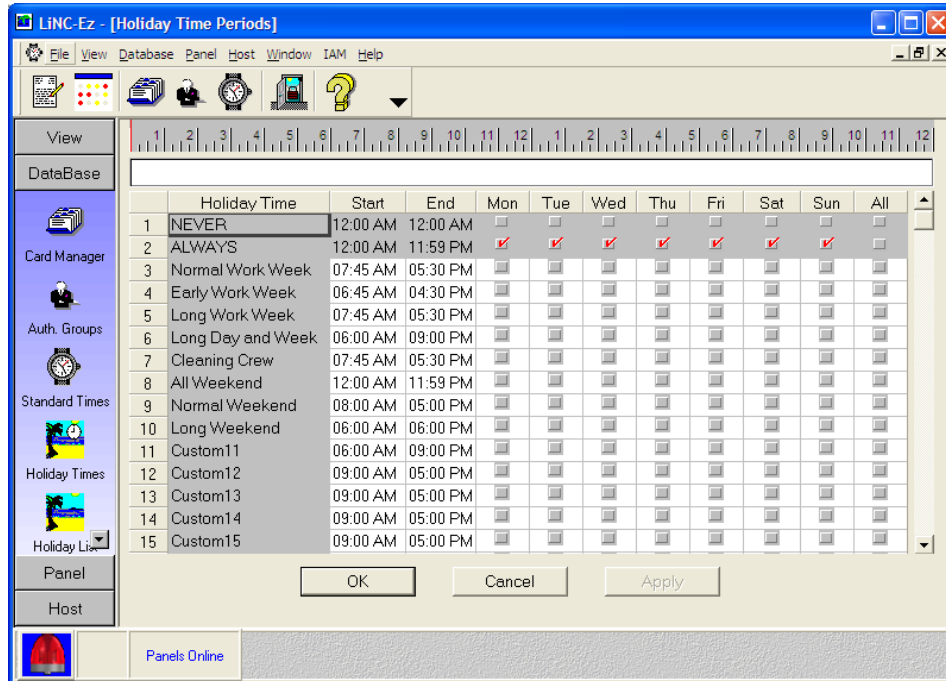

All Holiday Periods are inactive until programmed for Holiday use (except ALWAYS). Standard Time Periods will not function during a Holiday unless the user's Holiday Time Period schedule gives access.

**NOTE:** Holiday time periods start at 12 midnight.

Use the same steps to change the **Holiday Periods** as you did above in the **Standard Time Periods**.

**NOTE:** NEVER and ALWAYS are factory defaults and cannot be altered.

Select **Apply** or **OK** to save your data.

## 4.5 Holiday List

The **Holiday List** determines those days where the **Holiday Time Periods** are to be invoked.

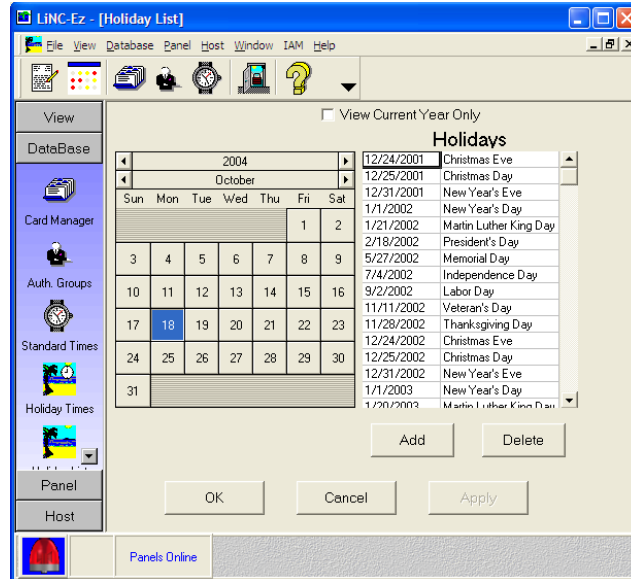

Holidays should be added by selecting the appropriate month, clicking on a day, and filling in the information in the **Holidays** column.

Select **Apply** or **OK** to save your entries.

## 4.6 Authorization Groups



An **Authorization Group (AG)** is used with the cardholder record. An AG is a list of readers and the time period in which these readers are accessible. Each cardholder can be assigned 4 Authorization Groups. When a card is presented to the reader, the panel checks the cardholders four AG and verifies that the card reader is valid within one of them. If the reader is not found in any of the Groups assigned to the cardholder, the system will deny access due to **“Invalid Reader”**. When a reader is found within the AG, the current time is checked with the Time Period associated with the AG. If the time is not valid, an **“Invalid Time Period”** transaction will be generated and access will be denied.

To set-up authorization groups:

1. Click the **Authorization Group** you are going to define.

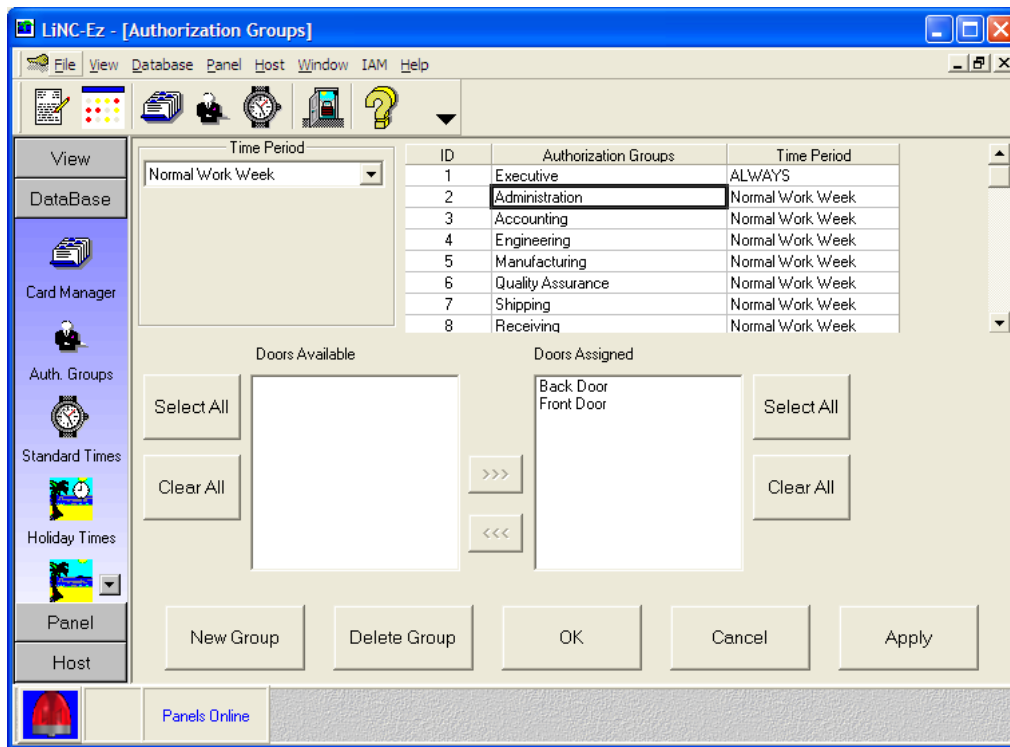

2. Use the **Time Period** down pointer, select the time period to assign. Clicking on the time period you will notice that the time period next to the ID will be changed accordingly.

3. In the areas below, select from the **Doors Available** to be allowed for the current group and use the transfer arrows to move those doors into the **Doors Assigned** column.

4. Select **Apply** or **OK** to make the selection active.

## 4.7 Card Manager

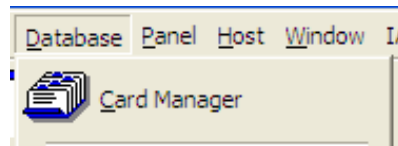

### 4.7.1 Adding Cardholders through the Overview and Detail Tabs

1. To **Add Cardholders** to the database, click **Database**, then **Card Manager**.
2. The **Card Manager** Screen appears:

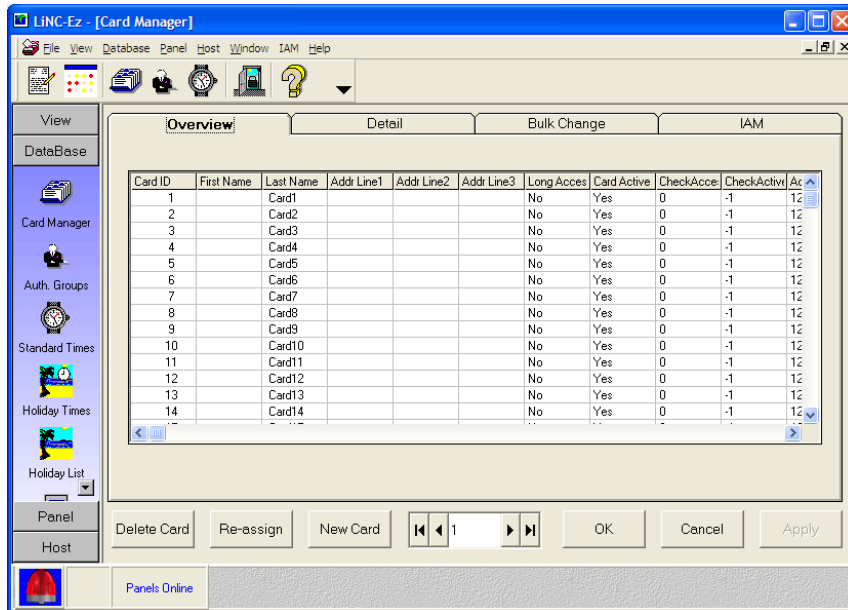

3. Click on the card number that you want to enter.
4. Click on the **Detail** tab to bring up the **Detail** screen.
5. Enter the **Name**, **Department**, **Company Name** and **Address**.
6. Enter **Phone** number and extension if appropriate.
7. Set the **Activation Date**.

**NOTE:**  
The Activation Date defaults to today's date. If the card activates on a different date than today then change the date.

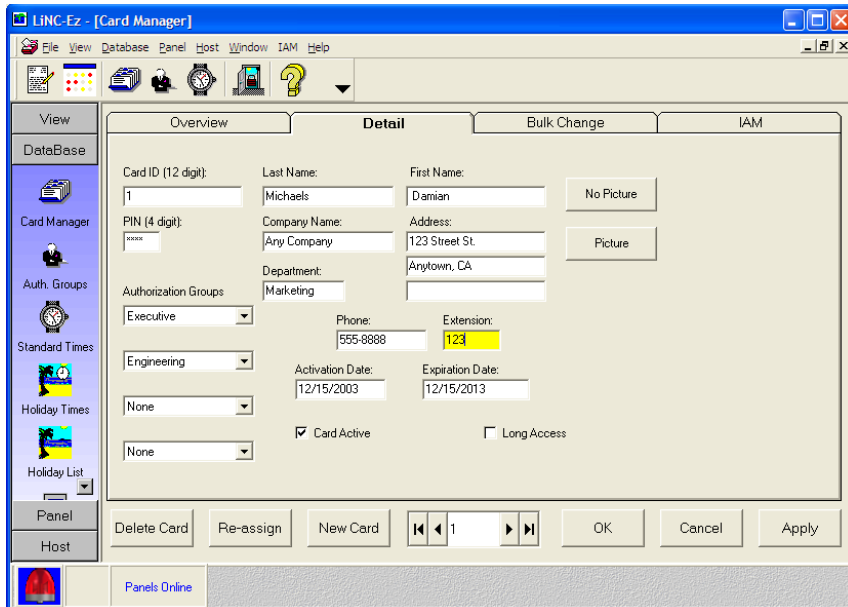

**NOTE:**  
All cards have a default expiration date of ten (10) years from issuance.

8. Select an **Authorization Group(s)** for the cardholder.
9. Set **Card Active** to activate the card.

**NOTE:** A card will not immediately activate if the activation date is set for the future.

10. Select **Long Access** to increase the amount of time the door can stay open without triggering an alarm.

11. **Picture** will add a **JPEG Picture File** to the card detail. Click **Apply** to save any changes the cardholder record.

12. Click on the right > of the **Change Record** tool to go to the next record.

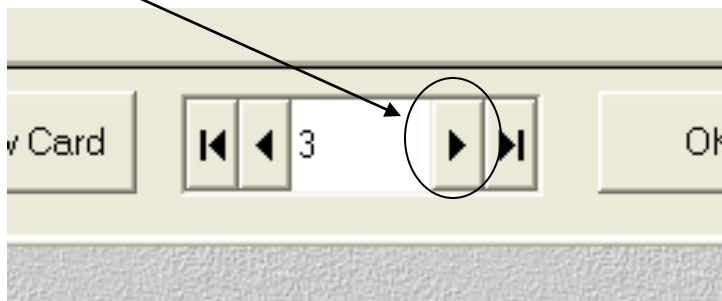

13. Return to the **Overview** screen to verify that the card you entered has been properly accepted.

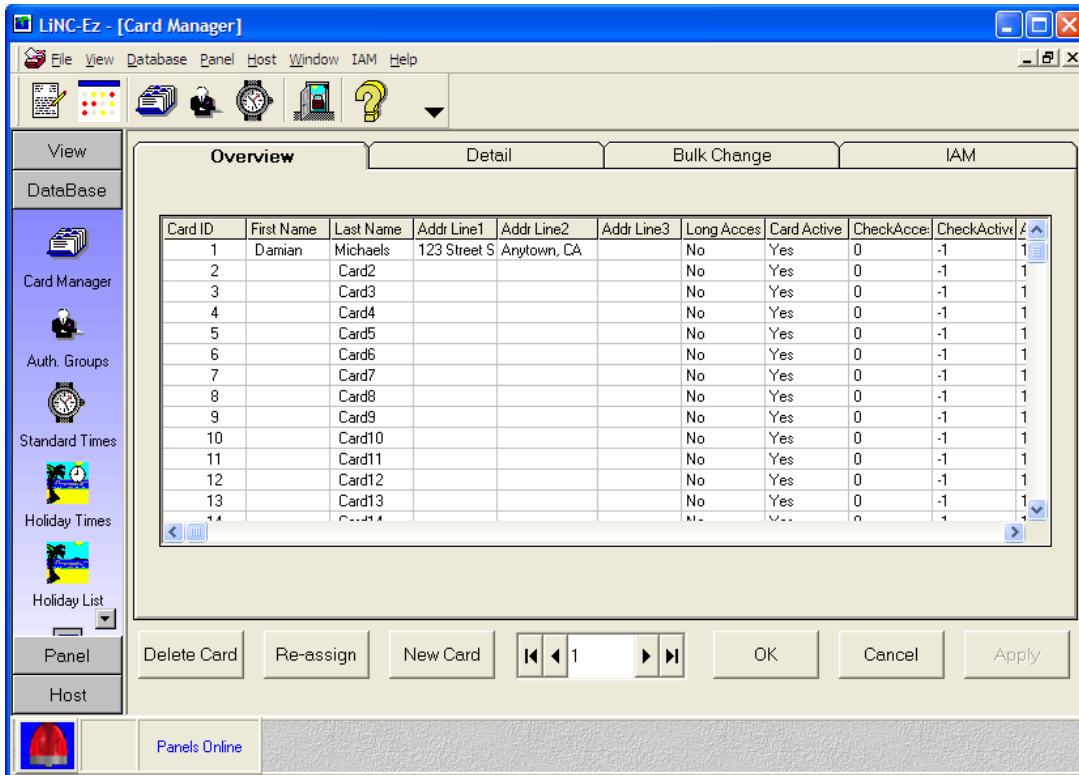

## 4.7.2 Alarm PIN User Number

Overview	Detail	Bulk Change	IAM
Card ID (12 digit): 11	<input type="checkbox"/> Alarm Company Employee		
The Alarm PIN copies the first two digits above automatically to the box below to show the complete User PIN to enter for arming and disarming.	Alarm PIN 19 0	Select from Dropdown Menu, the first two digits you would like the User PIN to be, or type it into the box to the left of the dropdown box.	
	Alarm Zone Group ZoneGroup2	Type in the remaining 2 to 4 digit number that will follow the first two digits in the Alarm PIN to complete the User PIN and click APPLY to save changes.	
	Keypad PIN 19 71		
The combined Alarm PIN and Keypad PIN constitutes the User PIN. The above example would arm with the number: 1971.			

**Alarm Company Employee** is a card for the alarm company. When selected card will not open or arm or disarm system unless an alarm has occurred. When system is normal, card presented to read will report to Central Station.

**Alarm PIN User Number** is first two digits of PIN number.

**Alarm Zone Group** is group armed or disarmed by PIN user.

**Keypad PIN** is last 2-4 digits of PIN number. Combine Alarm PIN User Number with Keypad PIN for user PIN number, i.e.: 01 and 11 pin number is 0111.



## 4.7.3 Using the iAM Panel

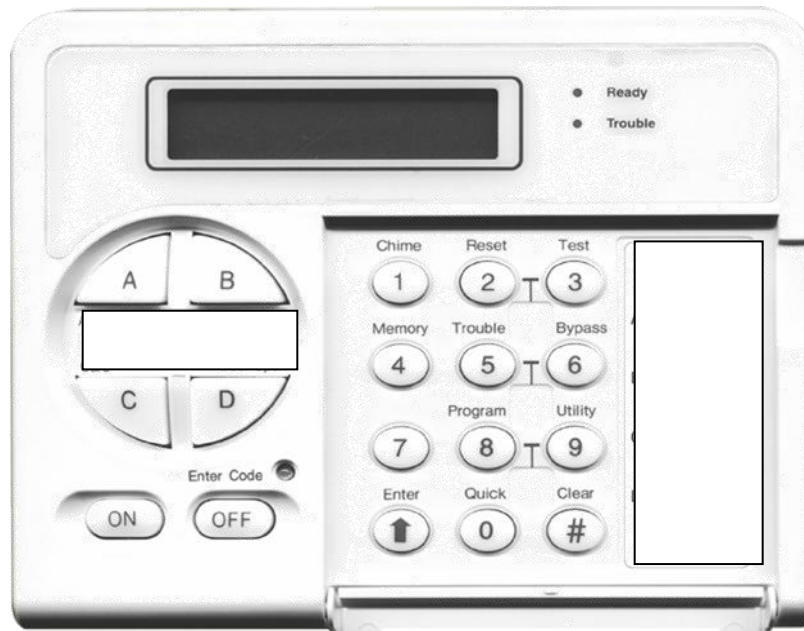

### 4.7.3.1 How to arm the iAM panel

**NOTE:** The keypad must display “Ready to Arm”, and the green **Ready** light will be on solid.

1. Press the **On** button; the **Enter Code** LED will light.
2. Enter your **User PIN code** (4 – 6 digit code).

**NOTE:** Default PINs are 0111, 0222, 0333, 0444, 0555.

3. Press the **Enter** button. The keypad will start to beep and the display will show **Please Exit**

**NOTE:** When the exit delay time nears the end, the keypad beeps rapidly to inform you the warning is ending and the display will show **Exit at Once**. Once the system is armed, keys **A, B, C, D** will light in some combination depending on how the system is programmed.

4. To cancel the “Arming” process before the exit time expires, press the **Off** button.

### 4.7.3.2 Bypassing zones

**CAUTION:** Bypassed Zones Are UNPROTECTED

If the keypad display does not show **Ready to Arm**, you may need to **Bypass** zones. The keypad display will show faulted zones. The display shows **Zone Warnings** with a zone number and a description of the protected area.

1. First check the faulted zone(s). These are the ones showing on the display of the keypad. Verify that the points of protection are normal; doors and windows are closed, motion detectors are working, or any protection device wired to the panel is working ok.
2. If you are unable to clear the **Zone warnings** from the keypad display, you may want to bypass the zones showing in order to arm the rest of the system.
3. Follow steps 1, 2, and 3 in Section 4.7.3.1 - **How to Arm the iAM Panel**.
4. After you press the **Enter** button, the faulted zone(s) will show, press the **On** button to bypass that zone. Press the **Enter** button to show the next faulted zone, if there are any more.
5. Once the last zone is bypassed, the system will arm.

### 4.7.3.3 How to Disarm the iAM panel

1. Press the **Off** button; the **Enter Code** LED will light.
2. Enter your **User PIN** code (4 – 6 digit code).
3. Press the **Enter** button..... **OR**, present a valid card to the card reader.

## 4.7.4 Bulk Change

The screenshot shows the 'Bulk Change' dialog box within the 'LiNC-Ez - [Card Manager]' application. The window has a menu bar (File, View, Database, Panel, Host, Window, IAM, Help) and a toolbar with icons for help, search, and other functions. The main area is divided into four tabs: Overview, Detail, Bulk Change (selected), and IAM. The Bulk Change tab contains the following fields:

- Department: [Text Box]
- Company Name: [Text Box]
- Address: [Text Box]
- Authorization Groups: [Dropdown Menu]
- Phone: [Text Box]
- Extension: [Text Box]
- Activation Date: [Text Box] (12/15/2003)
- Expiration Date: [Text Box] (12/15/2013)
- Card Active
- Long Access

At the bottom of the dialog is a 'Bulk Change' button. Below the dialog, the main application interface shows a 'Panel' tab selected, with buttons for 'Delete Card', 'Re-assign', 'New Card', a page indicator '1', 'OK', 'Cancel', and 'Apply'. A 'Panels Online' status bar is visible at the very bottom.

**Bulk Change** allows data to be populated into a range of cards in bulk rather than changing each record individually. Enter the data that will appear in each of the card records and then use the **Bulk Change** button to set up the range of cards to be affected.

**NOTE** You must download to panel before information is operational.

## 4.7.5 iAM

The **iAM** screen allows up to 99 individual cards to be specified for iAM alarm code access within particular zones, using a separate PIN number. Please note that only the reader on the iAM panel can disarm an iAM panel. A card can be defined to disarm both a common area (such as a lobby) and another area/areas.

The screenshot shows the 'Detail' tab of the iAM configuration interface. It includes a 'Card ID (12 digit)' field with '11' entered. Below it, a note explains that the Alarm PIN copies the first two digits of the Card ID. The 'Alarm PIN' field is a dropdown menu showing '19' and '0'. A note explains that the user should select from the dropdown menu the first two digits they want for the User PIN. The 'Alarm Zone Group' field is a dropdown menu showing 'ZoneGroup2'. A note explains that the user should type in the remaining 2 to 4 digit number that will follow the first two digits in the Alarm PIN. The 'Keypad PIN' field is a dropdown menu showing '19' and '71'. A note explains that the combined Alarm PIN and Keypad PIN constitutes the User PIN, with the example '1971'.

Each Card User can establish a six-digit iAM access code comprised of:

- 2-digit User Number
- 4-digit PIN number

**NOTE:** The keypad **MUST** be used to re-arm the panel. Therefore, PIN numbers **MUST** be setup. Up to 4 keypads can be attached to the system.

### 4.7.5.1 Setting an iAM access card PIN code:

1. From the top menu, click on **Database / Card Manager** or on the **Card Manager** icon.
2. Specify the Card ID that will be given the iAM access code.
3. Determine the Alarm PIN User Number from the dropdown box (to a maximum 99 users).
4. Determine the Alarm Zone Group that the cardholder will be a member. See section 4.13.3 for more information on the proper creation of Alarm Zone Groups.
5. Press the OK button to save the settings and close the window.

### 4.7.5.2 Establishing an Alarm Company Guard Card

In the event of an alarm, an Alarm Company Guard will be able to do the following:

- Ability to “register” at the customer site
  - Card transaction recorded and sent to the Central Station.
  - No Access granted
- Ability to Gain Access during an Alarm Condition

To establish a card to be a specific Alarm Company Guard card, select the **Alarm Company Employee** checkbox. Follow the instructions for 4.7.1 as stated to finish the card programming.

### 4.7.5.3 iAM Zone Configuration

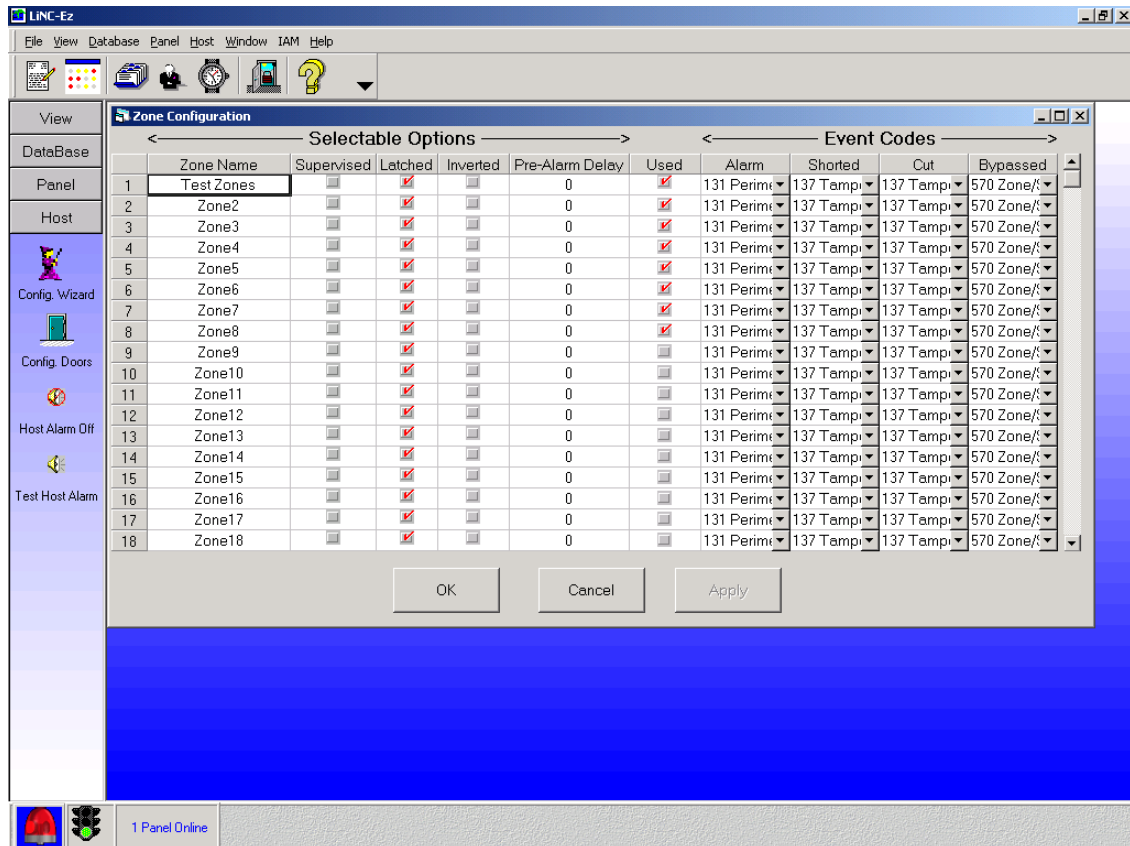

<b>Zone Name</b>	Identifies zones. Name can be changed here.
<b>Supervised</b>	Must be selected for zone points with supervising resistors. Note: changing DRSTS-Door will change door supervised status in Configure Doors\Door Properties.
<b>Latched</b>	Will latch each zone violation. Latch will report the violation only once.
<b>Inverted</b>	Will invert the zone point normal condition.
<b>Pre-Alarm Delay</b>	Will allow seconds of delay before zone violation will be reported.
<b>Used</b>	Will indicate if Zone has been entered in Zone Group. This is automatically done.
<b>Event Codes</b>	Are the codes sent to Central Station when Alarm, Shorted, Cut or Bypassed violation occurs. Codes are transmitted via Contact ID format.

#### 4.7.5.4 Creating Zone Groups

1. Select ZoneGroupID, then select from Zones Available and move to Zones Assigned.
2. Do this for each ZoneGroupID required.
3. Apply when complete.

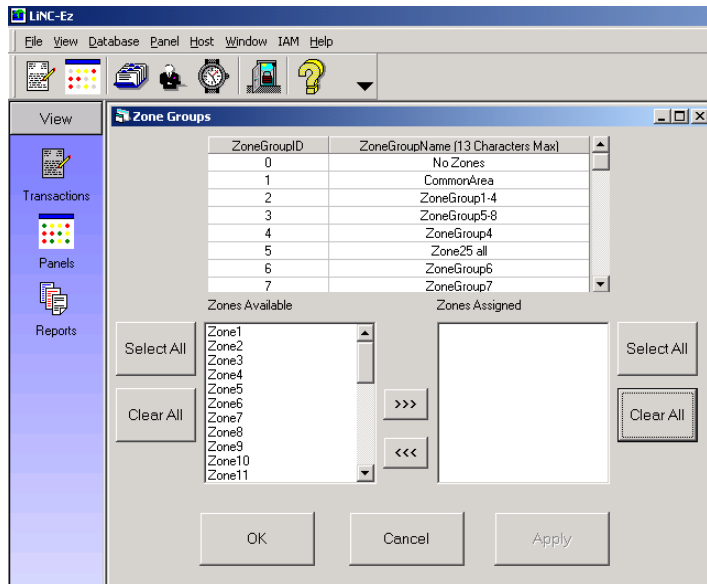

#### 4.7.5.5 Calibrate or Suppress Alarm Zones

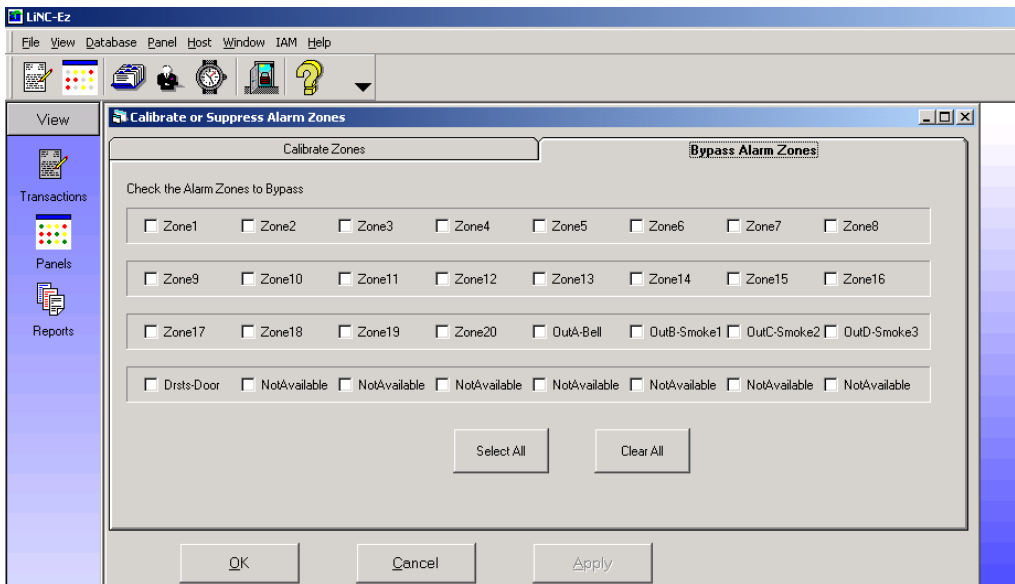

- Calibrate Zones** Will calibrate supervised zone points. Select and Apply.
- Bypass Alarm Zones** Will suppress zone reporting for one Alarming.

#### 4.7.5.6 Central Station Configuration

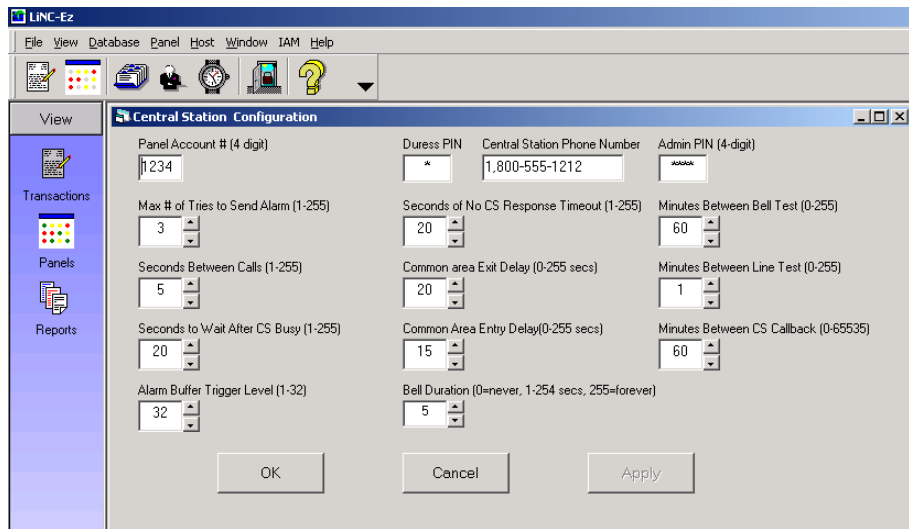

<b>Panel Account #</b>	The unique number for iAM sent to Central Station.
<b>Max # of Tries to Send Alarm</b>	(1-255) will set number retries of alarm to Central Station once the iAM is communicating with Central Station. If the iAM and Central Station is online but Central Station does not acknowledge the alarm after set retries, the iAM will consider alarm sent.
<b>Seconds Between Calls</b>	Sets seconds for dialup. When iAM encounters an alarm it will delay for set number of seconds before dialing Central Station.
<b>Seconds to Wait After CS Busy</b>	Sets number of seconds to redial if Central Station line is busy.
<b>Alarm Buffer Trigger Level</b>	Sets the number of Alarms before iAM overrides the Seconds Between Call delay to dials the Central Station.
<b>Duress PIN</b>	Number added to end of User PIN to send silent alarm to Central Station.
<b>Central Station Phone #</b>	The Central Station number.
<b>Admin PIN</b>	Number to enter Administration features at keypad on iAM.
<b>Seconds of No CS Response Timeout</b>	Sets the seconds to hang up if Central Station does not communicate.
<b>Common area Exit Delay</b>	Sets time to leave and secure building.
<b>Common Area Entry Delay</b>	Sets time to delay before reporting alarm if no pin number disarms iAM.
<b>Bell Duration</b>	Sets length of Bell output A. Zero for never; 1-254 seconds or 255 forever.
<b>Minutes Between Bell Test</b>	Monitors Bell condition.
<b>Minutes Between Line Test</b>	Monitors phone line condition.
<b>Minutes Between CS Callback</b>	Sets the regular time period iAM call into Central Station.

## 4.8 Import and Export



### 4.8.1 Import

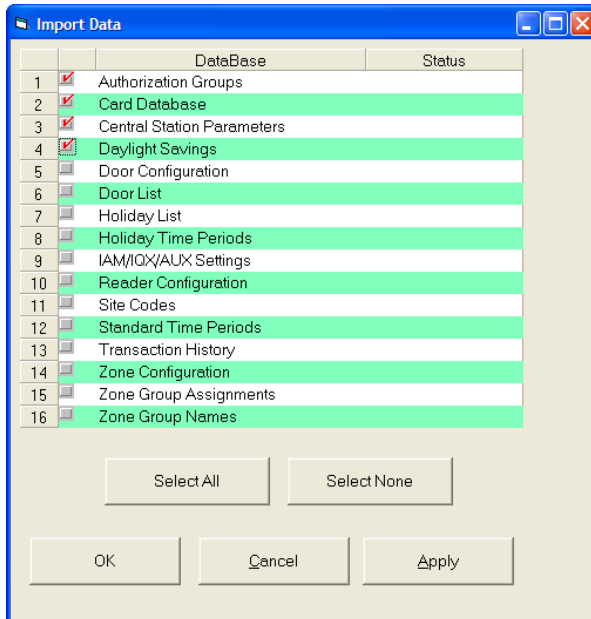

In the event that an administrator needs to import card information from a separate LiNC-Ez iAM™ system, the **Import** feature will override the existing LiNC-Ez iAM™ database.

1. By selecting **Import** from the **database** menu, the Import window appears.
2. Select the LiNC-Ez iAM™ features that you wish to import (see below).
3. Click the **OK** button. **Save In** window will appear with the title “**Choose a database to backup to**” with the default name **Export.mdb**.
4. Choose a database file to restore from and click the **Save** button.

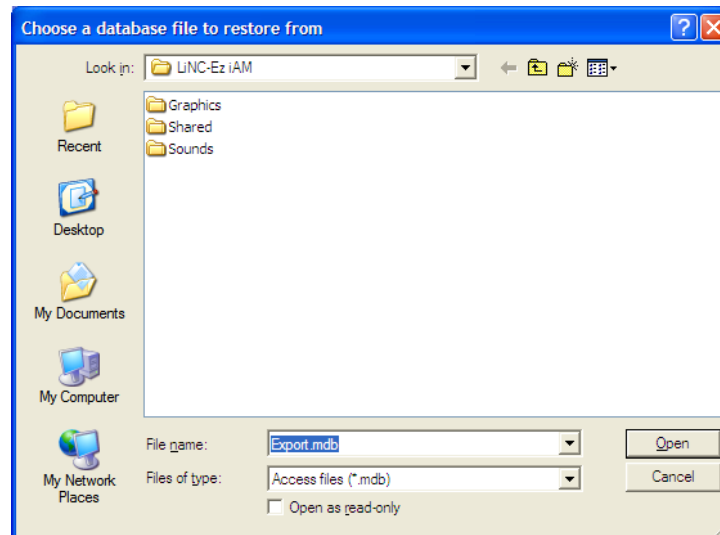

**NOTE:** Importing a new database file will **OVERWRITE** the current database.



## 4.8.2 Export

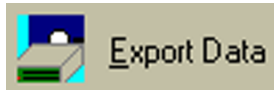

LiNC-Ez™ has added a new feature that allows an administrator to export the existing LiNC-Ez™ database. This is beneficial for archiving, Emergency back-up, and for transferring the database to another computer.

1. By selecting **Export** from the database menu, the **Export Data** window appears.
2. Select the LiNC-Ez iAM™ features that you wish to export to a different copy of LiNC-Ez iAM™ (see below). Click the **OK** button.
3. A **Save As** window will appear with the title “**Choose a database file to back up to**” with the default name of **Export.mdb**. Choose an appropriate location for the exported database, and click the **Save** button.

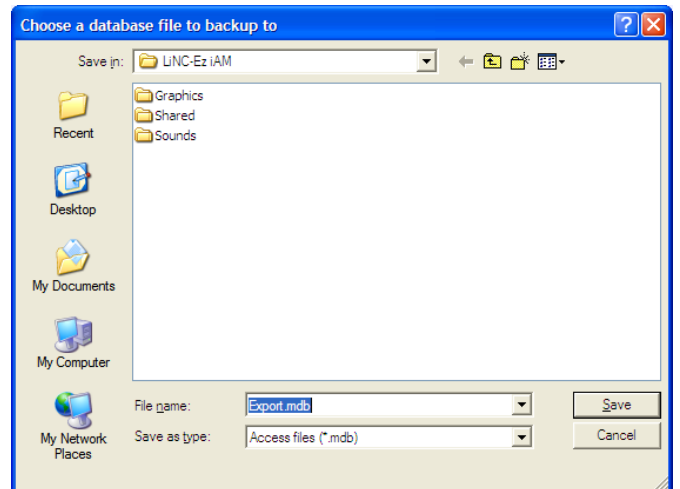
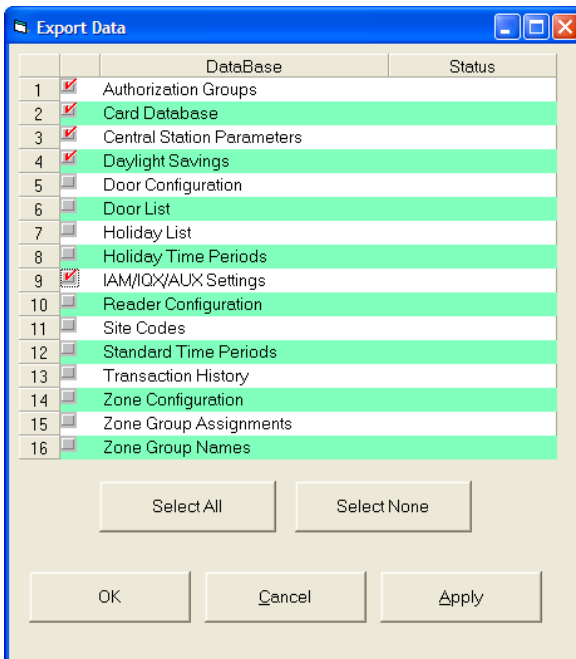

**NOTE:** Export you parameters regularly. This information is necessary for recovery.

## 4.9 Download/Broadcast

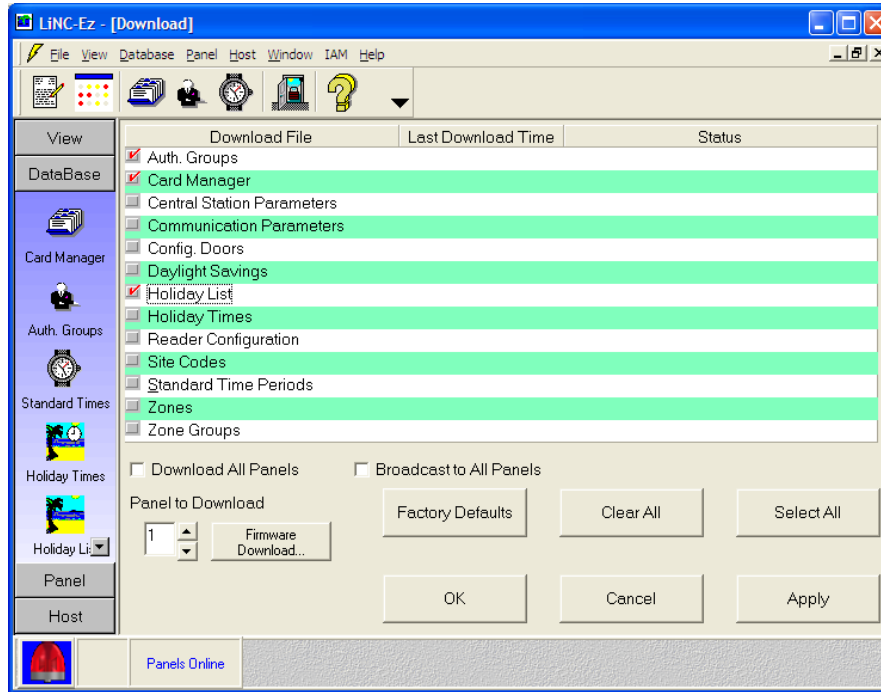

**NOTE:** Cards will not operate in the panel system until the first download of the LiNC-Ez iAM™ system.

Once the parameters have been set up, they are downloaded from this screen.

1. Select files to download
2. Select **Download All Panels** or **Broadcast to All Panels**.
3. Click the **Apply** button.

During the download, a progress bar appears near the bottom of the screen to give you the current status. **Broadcast to All Panels** will download all panels on a loop.

To set **Factory Defaults**:

1. Select the **File** menu item
2. Click the **Factory Default** button. *Only use this button when you want return to Factory Default. It will **not download** to panel.*
3. You must exit Linc-Ez, then re-enter for defaults to take effect.

**NOTE:** **Firmware Download** allows upgrade for new panel application firmware, **not** to download parameters.

## 4.10 Transaction Monitor

The **Transaction Monitor** screen presents each of the transactions occurring on the system.

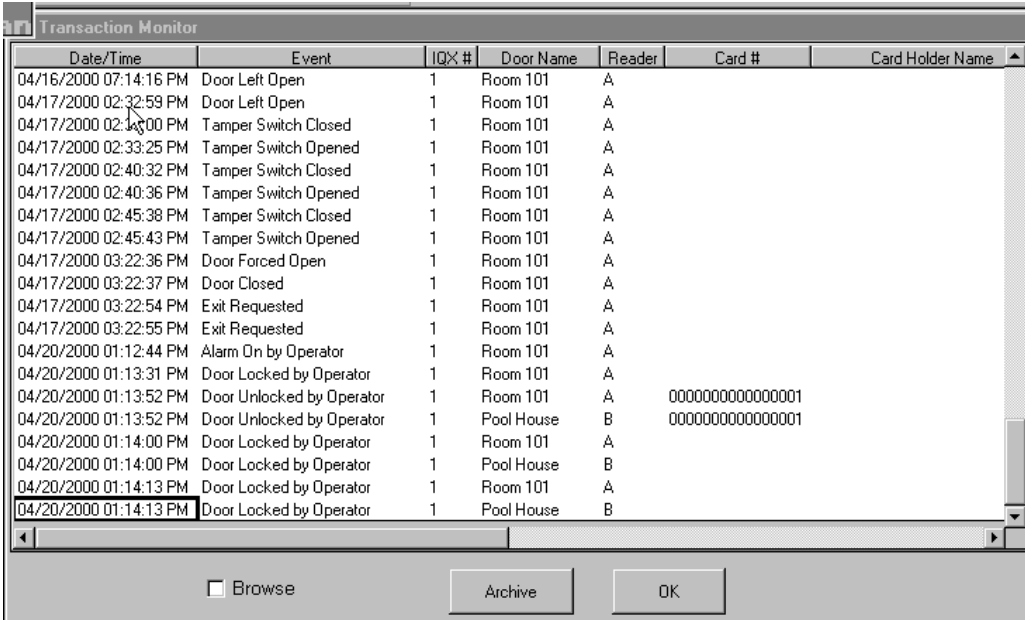

Date/Time	Event	IQX #	Door Name	Reader	Card #	Card Holder Name
04/16/2000 07:14:16 PM	Door Left Open	1	Room 101	A		
04/17/2000 02:32:59 PM	Door Left Open	1	Room 101	A		
04/17/2000 02:33:00 PM	Tamper Switch Closed	1	Room 101	A		
04/17/2000 02:33:25 PM	Tamper Switch Opened	1	Room 101	A		
04/17/2000 02:40:32 PM	Tamper Switch Closed	1	Room 101	A		
04/17/2000 02:40:36 PM	Tamper Switch Opened	1	Room 101	A		
04/17/2000 02:45:38 PM	Tamper Switch Closed	1	Room 101	A		
04/17/2000 02:45:43 PM	Tamper Switch Opened	1	Room 101	A		
04/17/2000 03:22:36 PM	Door Forced Open	1	Room 101	A		
04/17/2000 03:22:37 PM	Door Closed	1	Room 101	A		
04/17/2000 03:22:54 PM	Exit Requested	1	Room 101	A		
04/17/2000 03:22:55 PM	Exit Requested	1	Room 101	A		
04/20/2000 01:12:44 PM	Alarm On by Operator	1	Room 101	A		
04/20/2000 01:13:31 PM	Door Locked by Operator	1	Room 101	A		
04/20/2000 01:13:52 PM	Door Unlocked by Operator	1	Room 101	A	0000000000000001	
04/20/2000 01:13:52 PM	Door Unlocked by Operator	1	Pool House	B	0000000000000001	
04/20/2000 01:14:00 PM	Door Locked by Operator	1	Room 101	A		
04/20/2000 01:14:00 PM	Door Locked by Operator	1	Pool House	B		
04/20/2000 01:14:13 PM	Door Locked by Operator	1	Room 101	A		
04/20/2000 01:14:13 PM	Door Locked by Operator	1	Pool House	B		

Check the **Browse** box to prevent the screen from updating while you scan through entries.

Archive the transactions by clicking the **Archive** button. You will be asked for the number of days prior to today to archive. To archive the last week, enter 7; to archive the last month, enter 30. Archive will remove transactions from LINC-Ez iAM™. The archive is located in the CSV file, and is compatible with a spreadsheet or database.

**NOTE** When **Transaction Monitor** refreshes *slow*, **Archive the Transaction Monitor**.

Select **OK** to close this screen.

## 4.11 Site Codes



A Site Code (also known as a Facility Code) allows independent operation of each LiNC-Ez iAM™ system. In a multi-tenant building with multi- LiNC-Ez iAM™ is they would run completely independent.

The Multi-Site Code feature allows up to 16 site codes on one LiNC-Ez iAM™. This has the added benefit to program only one LiNC-Ez iAM™ with or without Site Code separation.

1. Select Site codes from the Database top menu or vertical menu selection.
2. Highlight --- (dashes) in Site Code # column, and type in site code number.

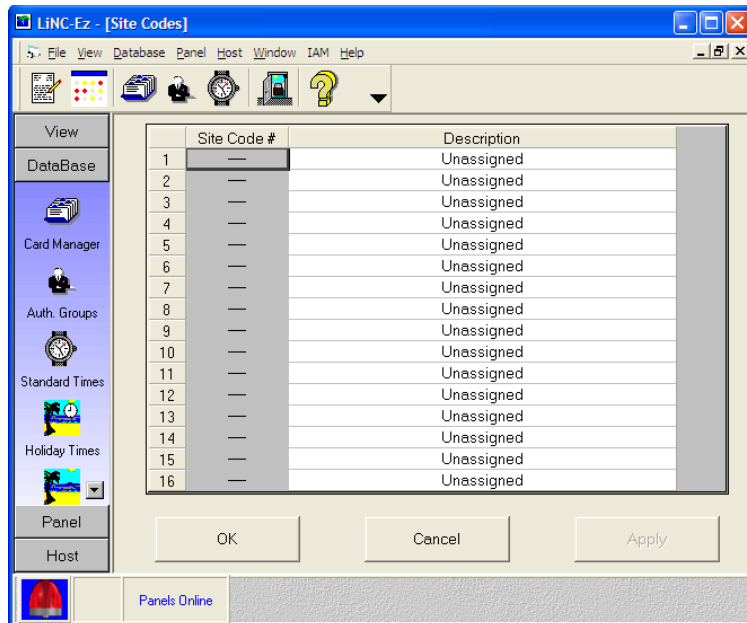

**NOTE:** The original Site Code(s) is located on the CD and will automatically load upon installation.

3. To finish the job, select **Apply** and **OK**.



## 4.13 iAM Security Management

Each iAM panel has 21 inputs and 99 zones that can be programmed using LiNC-Ez™. This section discusses the proper method of Configuring Alarm Zones and Alarm Groups and how to set the Central Station.

### 4.13.1 Configuring Alarm Zones using LiNC-Ez™

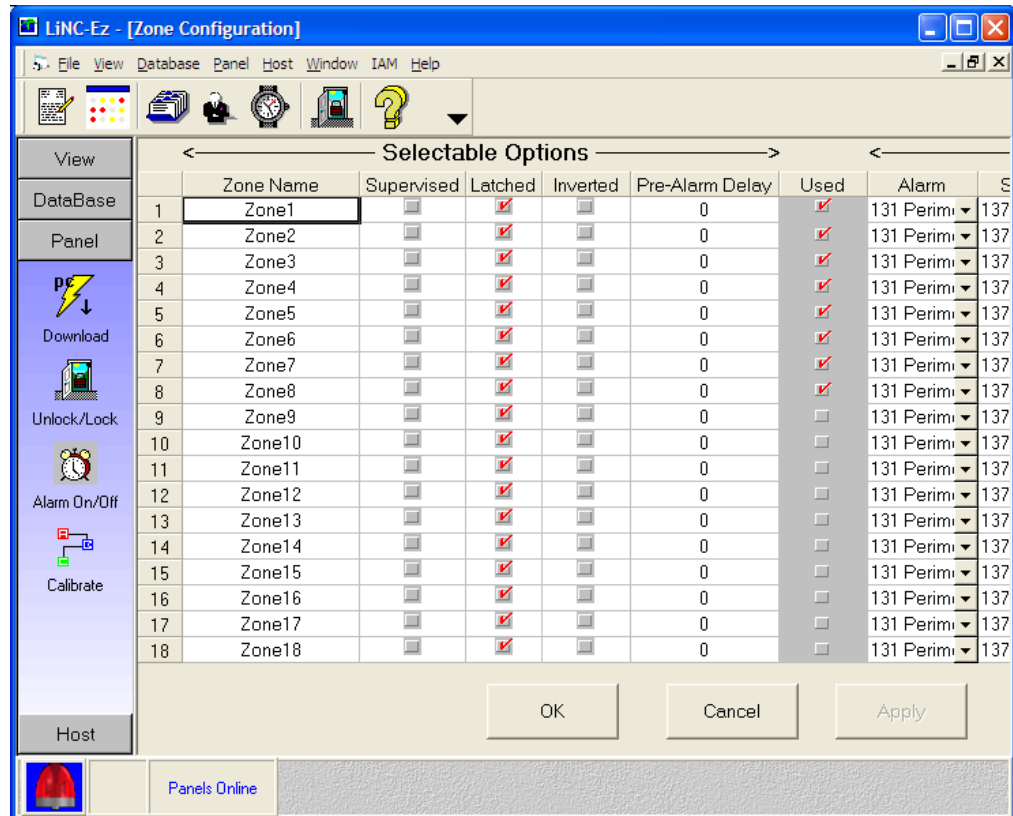

Each Zone is comprised of two general features, the Selectable Options and the Alarm Event codes.

The Selectable Options are the:

- Zone Name
- Supervised
- Latched
- Inverted
- Pre-Alarm Delay

LiNC-Ez™ automatically establishes default Alarm Event codes:

- Alarm            131 Perimeter Alarm
- Shorted        137 Tamper
- Cut             137 Tamper
- Bypassed      570 Zone/Sensor/Bypass

However, other event codes can be substituted for the default codes through the dropdown boxes.

## 4.13.2 Setting the Parameters for the Central Station Notification

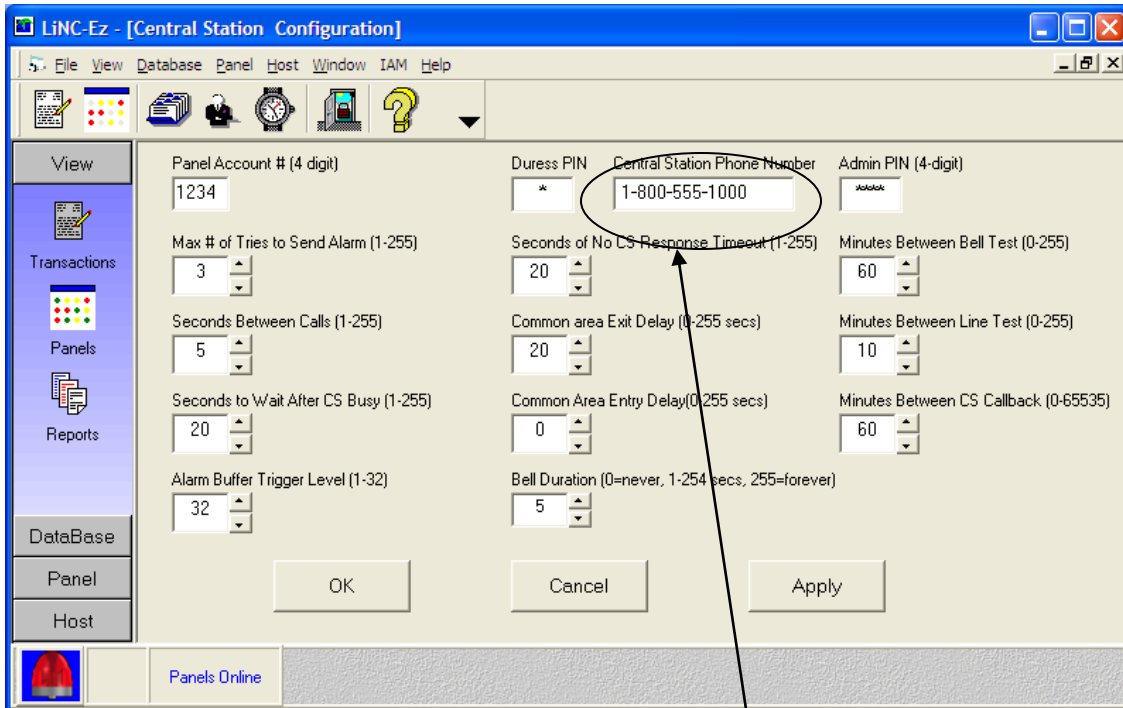

LiNC-Ez™ connects to the Central Station through the built-in modem on the iAM panel. In order to contact the central station, the phone number needs to be programmed into LiNC-Ez™.

1. From the top menu, press **iAM / Central Station Configuration**.
2. Enter the phone number for the Central Station.
3. Press the **Apply** button to save the change.
4. If you wish to change any of the additional settings for contacting the Central Station, do so at this time.
5. Press the **OK** button to save your settings and close the **Central Station Configuration** window.

### 4.13.3 Configuring the Zone Groups

A Zone Group is a combination of different zones identified by a common name and used for ease in programming.

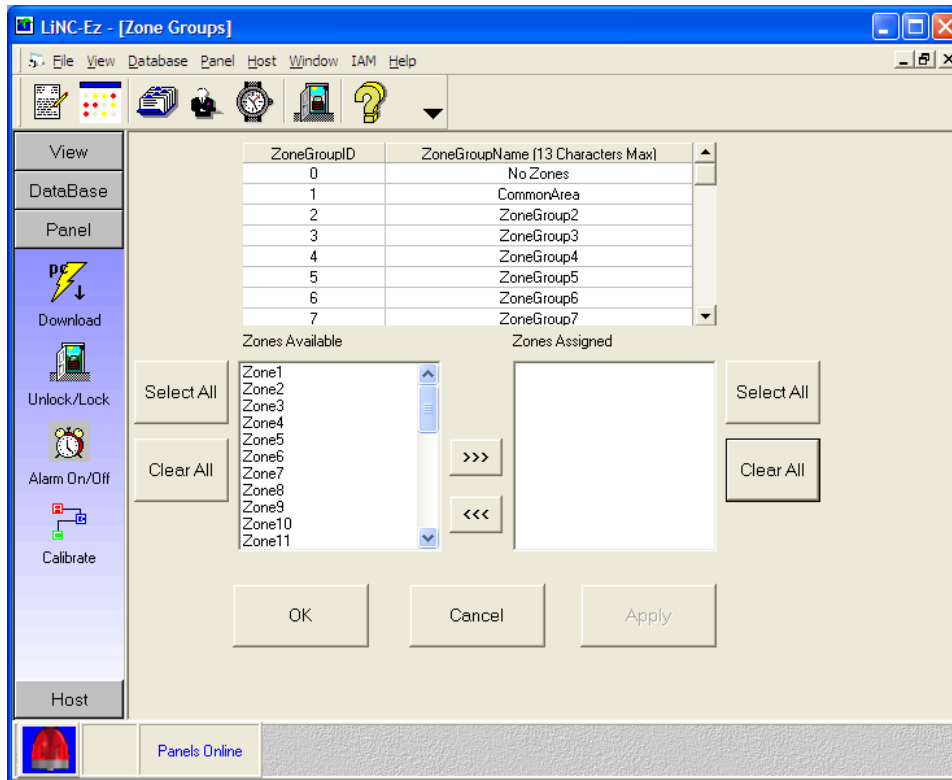

Each Zone Group can hold a selectable number of Zones. LiNC-Ez™ comes with a default setting for the first three Zone Groups:

- Zone Group 0 – No Zones
- Zone Group 1 – Common Area
  - Bell Output
  - Door Status
- Zone Group 2 – Alarm Zones 1-8

To create a custom Zone Group:

1. From the top menu, select iAM / Zone Group Configuration.
2. Select the appropriate Zone Group (3-99) that you wish to program.
3. In the Zone Available window, select the Zones to be assigned to the Zone group. Use the CTRL button to highlight individual zones.
4. Press the arrow button to move the selected zones to the Zones Assigned window.
5. Press the Apply button to save the selection or press the OK button to save the selection and close the window.



## 4.13.4 Calibrating a Supervised Alarm Zone

Alarm Zones are system Defaulted to “Non-Supervised” from the Factory. LiNC-Ez™ has the ability to create a Supervised Alarm Zone. However, you must define a Zone for “Supervision” before Calibrating can be accomplished. Also, PCSC approved End of Line resistors must be installed to provide accurate monitoring. Only twenty zones can be programmed. In order establish supervision, a Zone needs to be selected for supervision via the Zone Configuration screen.

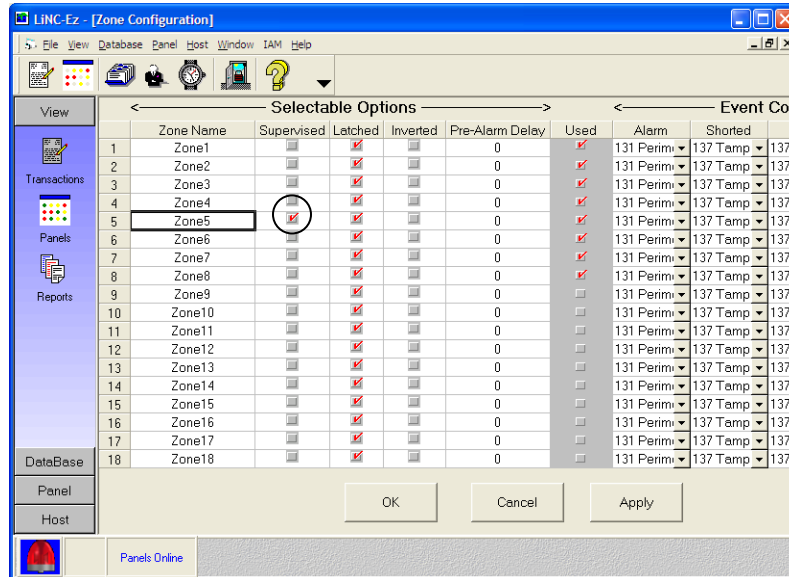

1. From the top menu, select **iAM / Zone Configuration**.
2. Find the zone(s) that is to be supervised and select the checkbox in the **Supervised** column.
3. From the top menu, select **iAM / Calibrate or Suppress Alarm Zones**.

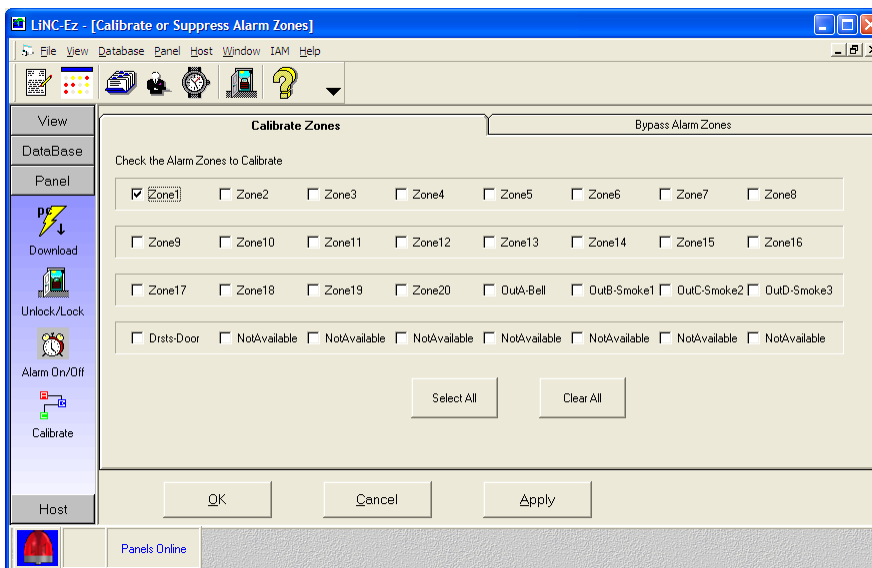

4. Select the zone(s) that is to be calibrated.
- Press the Apply button to save your changes, or press the OK button to save your changes and exit the window.

# 5.0 LiNC-Ez Communication

## 5.1 Single Modem; Multiple Panel (SMMP)

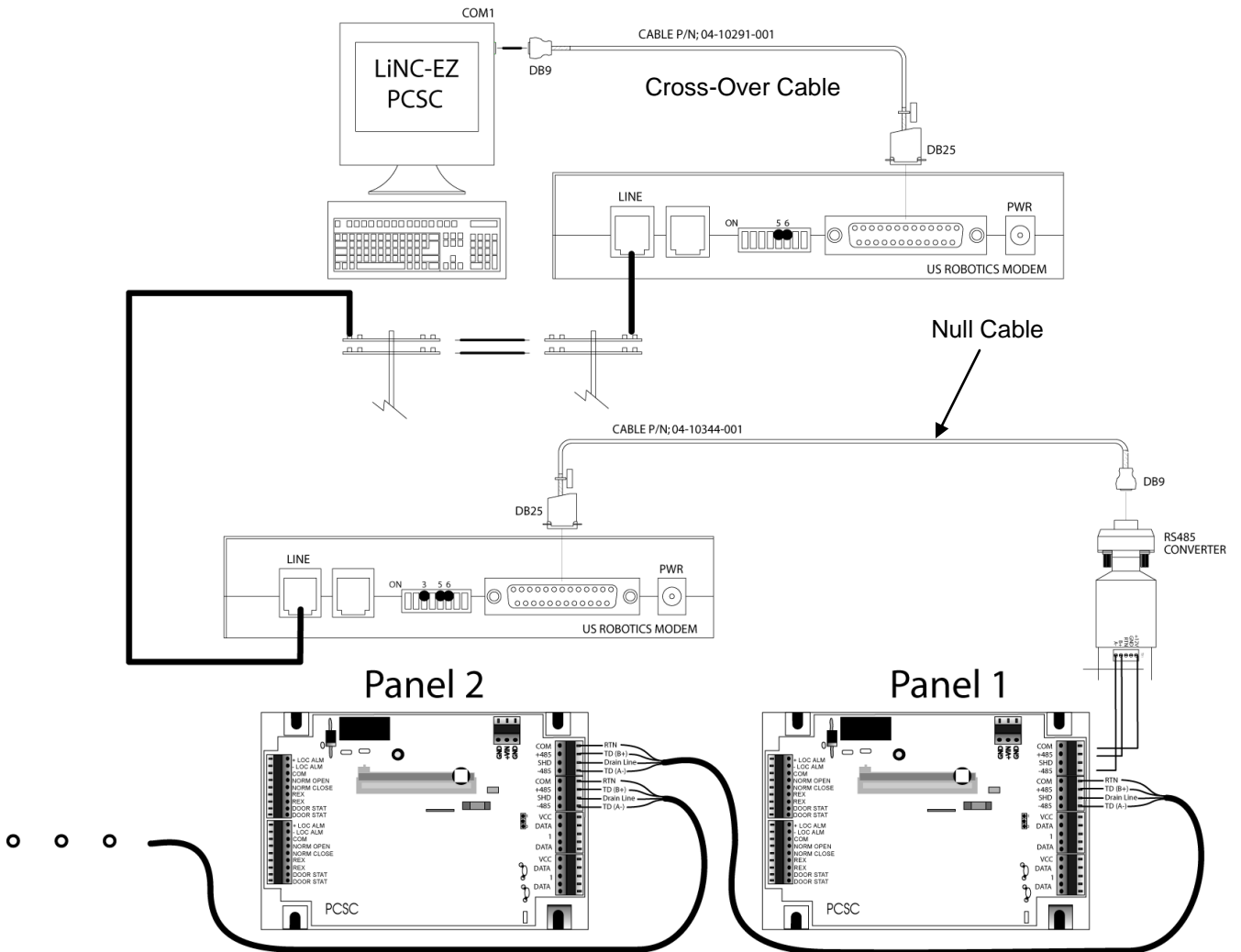

### 5.1.1 Connecting the Modem

At the LincEZ PC-

A standard modem cable (p/n: 04-10291-001) is connected between the PC's DB9 comport to the modem's DB25 connector. Plug one end of your phone cord into the jack labeled LINE on the modem and the other end into a phone wall jack (see diagram). Follow all modem installation instructions for proper handling and power requirements.

**NOTE:** For proper operation, please use a single pair of external PCSC US Robotic Modems 33K or greater w/ Dipswitch (PCSC model # MODAEXT).

Set PC **modem** DIP Switch:

- 5 – Up (Auto Answer on First Ring)
- 6 – Up (Carrier Detect Normal)
- All other DIP Switch OFF

PC **modem** setup:

1. Power modem; reboot the PC System. Install New Hardware Found; select Standard Modem driver
2. After the Standard Modem has been installed, go to the Control Panel \ Modem \ Properties and set parameter as:
  - Data bits – 7
  - Parity – odd
  - Stop bits – 1
  - No Flow Control
  - “Wait for dial tone before dialing” checked

### 5.1.2 Panel Loop

The Panel Loop can handle 1-32 panels. All panels must be wired as directed in installation manual. RS 485 wiring is Plus (+) to Plus (+); Minus (-) to Minus (-); Com connected all Com; All Shield connected to ONE earth ground. The Panel Loop modem has special cable (p/n # 04-10344-001) to RS485 converter. Attach Panel Loop phone line to modem.

Set **Panel**:

All panels in the loop must be set to modem mode. On **Panel PCB** set dip switch #8 – ON (toward LED) The dip switch #8 set the panel in modem mode.

Set Loop **modem** DIP Switch:

- 3 – Up (Suppress Results Codes)
- 5 – Up (Auto Answer on First Ring)
- 6 – Up (Carrier Detect Normal)
- All other DIP Switch OFF

**WARNING:** Don't confuse the DIPswitch settings on the modem and the panel. They are not the same.

## 5.2 Modem SMMP Programming

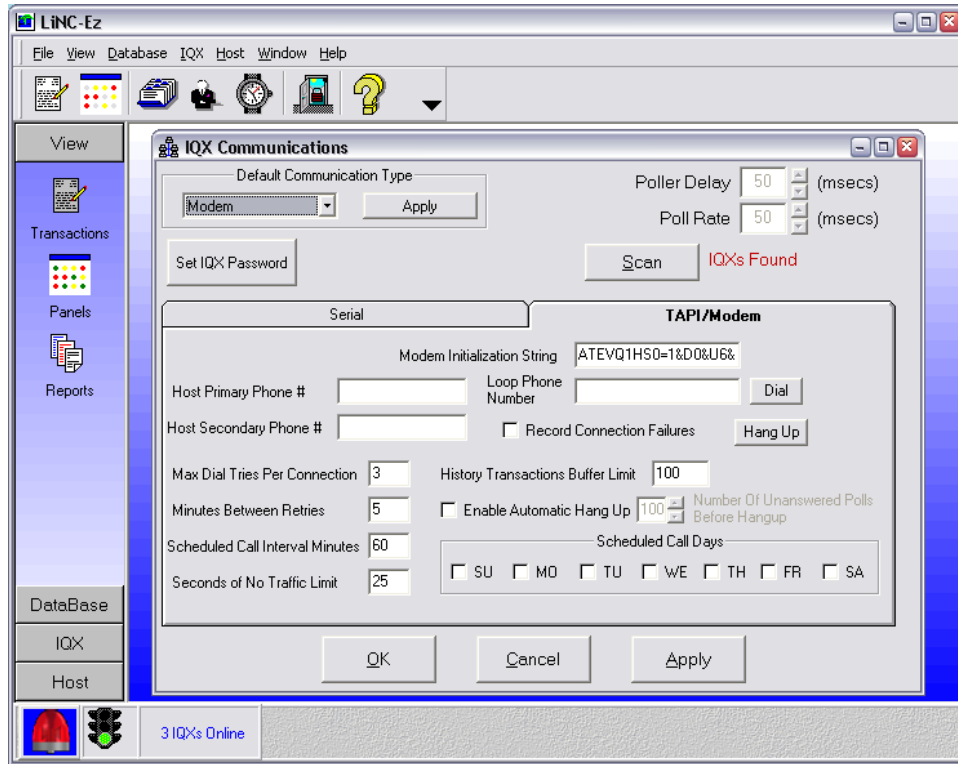

Pull down from Top Menu **Panel** and select **Panel Communications**. In *Default Communication Type* pull down select **Modem** and Apply.

In **TAPI/Modem** enter:

<b>Host Primary Phone #</b>	First phone number IQ Loop will dial for alarm condition
<b>Host Secondary Phone #</b>	If the Primary Host line does not engage, then the Secondary phone number will be called. If no Secondary line is available, then reenter the Primary Phone number. If no Secondary Phone number is present, then phone line will incorrectly dial second number.
<b>Loop Phone Number</b>	Enter Phone number for panel Loop.
<b>Dial button</b>	Will dial Loop Phone number.
<b>Hang Up button</b>	Hang up manual the Loop Phone number.
<b>Max Dial Tries Per Connection</b>	Enter Maximum number of tries to connect.
<b>Minutes Between Retires</b>	Enter number of minutes between retries.
<b>Schedules Call Interval Minutes</b>	Enter number of minutes between Schedule calls on Schedule days.
<b>Seconds of No Traffic Limit</b>	Time before phone call attempted.

## 5.2.1 Computer Configuration

In order to have modem communication, COM 1 of the computer must be configured.

1. Right click on **My Computer** icon and select **Properties**. In the pop up window, select the **Hardware** tab and click on **Device Manager**.

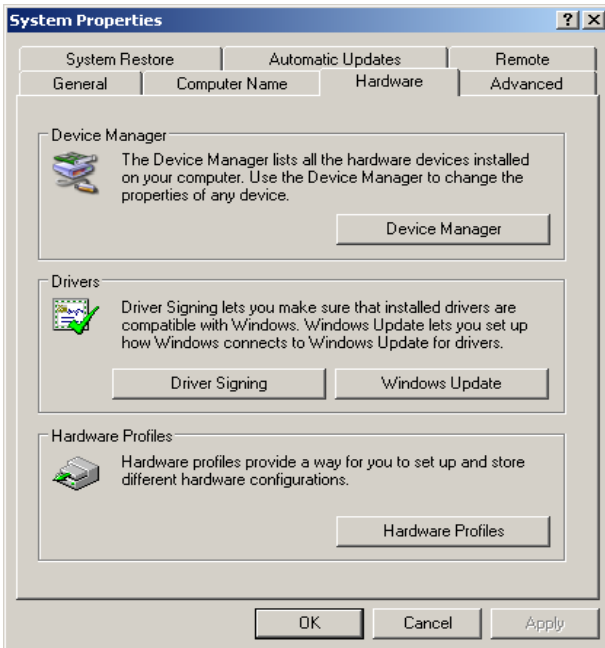

2. Find and open **Ports** and double click on **Communications Port COM 1**.

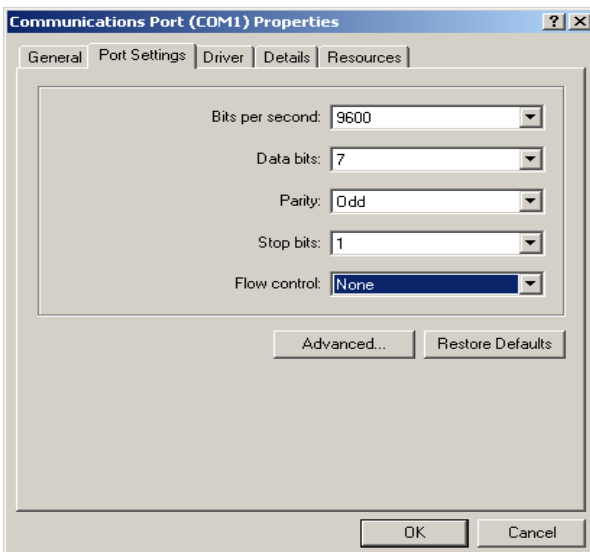

3. Select the **Port Settings** tab and change the settings to **9600** Bits per second, **7** Data bits, **Odd** Parity, **1** Stop Bit, and **None** for Flow Control. Click on **OK**.

## 5.2.2 Modem Configuration

1. Click on the **Start** button at the taskbar. Click on **Settings** and open up the **Control Panel**. Double click on **Phone and Modem Options**.

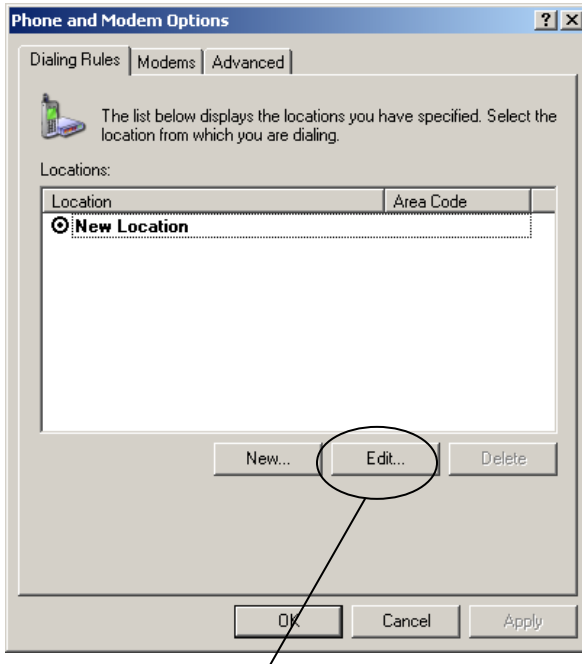

2. Click on the **New** button in the **Dialing Rules** tab.

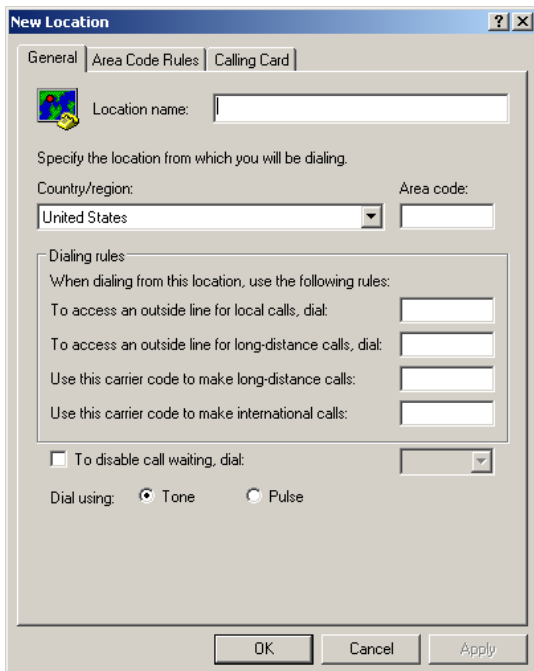

3. Type in the location name and select the Country/region and type in the area code. Make sure that the **Tone** is selected for **Dial using**. Click on **Apply** for the changes to take effect.

## 5.2.3 LiNC-Ez™ Panel Communications

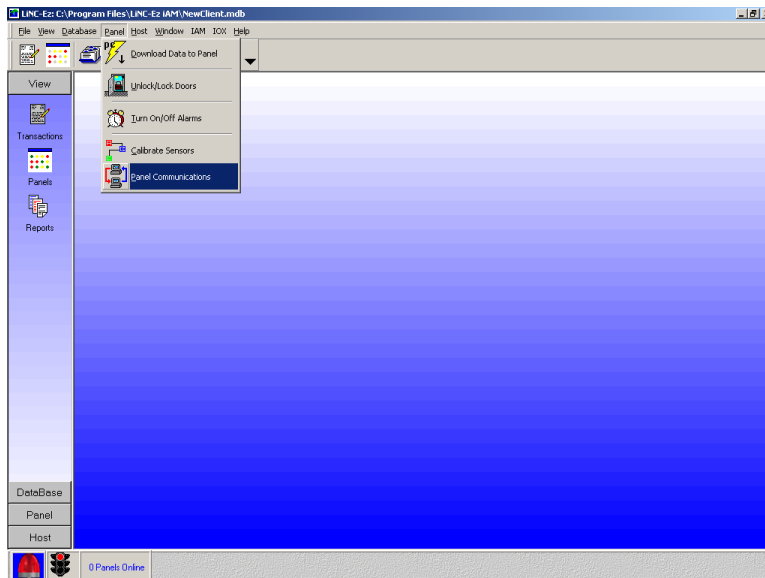

1. In the top menu, select **Host** and click on **Panel Communications**.

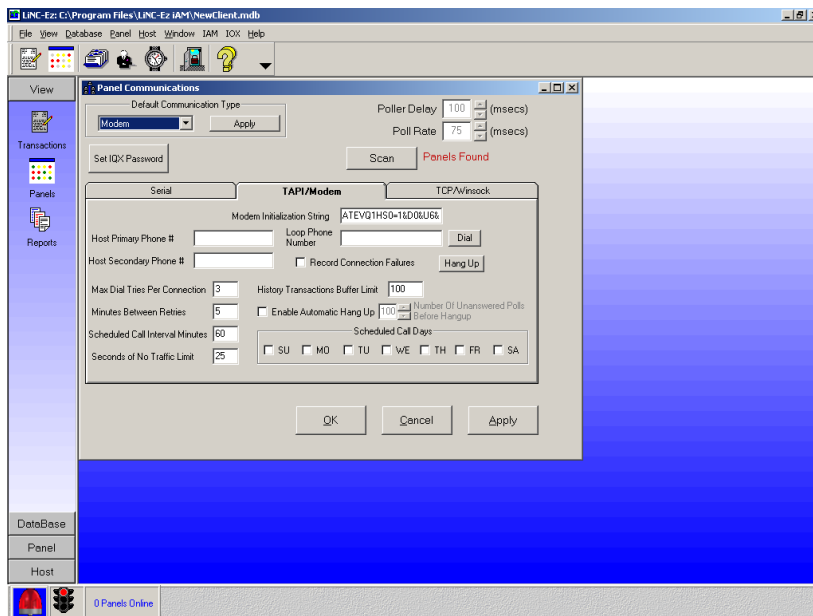

2. Change Default Communication Type from Serial to **Modem** and click on the **Apply** button.
3. Click on the **TAPI/Modem** tab and in the **Loop Phone Number** box, type in the phone number to the iAM panel (This is for communication between the PC and the iAM). Click on the **Dial** button to establish communication.

## 5.2.4 iAM Modem Communication Setup

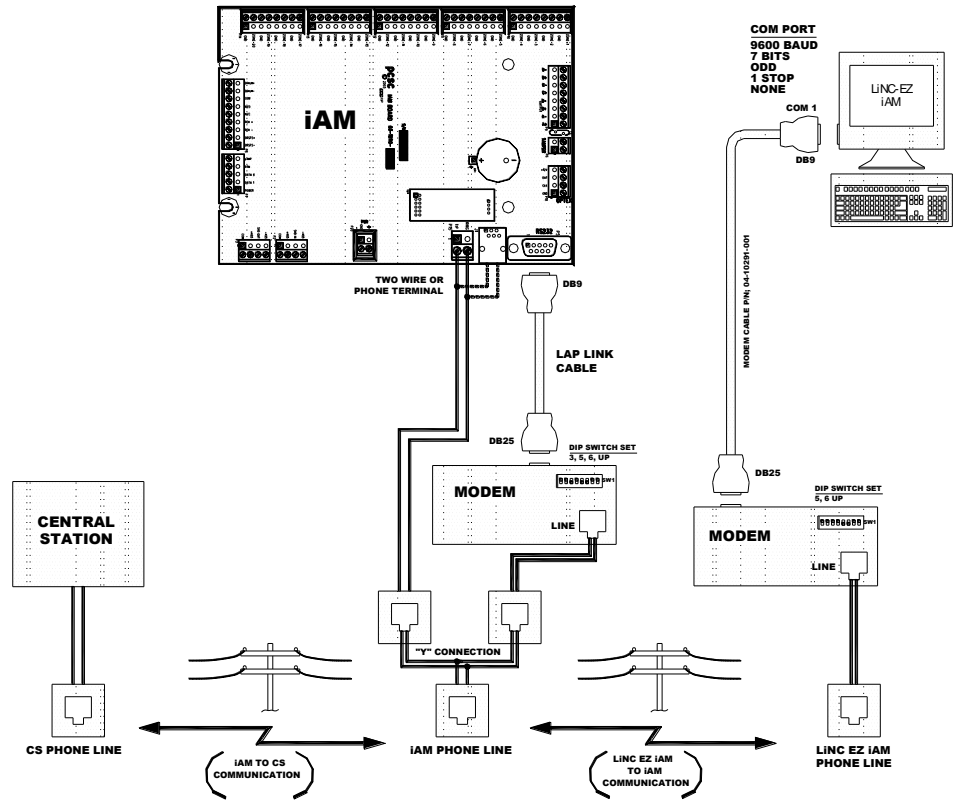

Three dedicated phone lines and two modems are required. One modem and phone line is needed for the PC (for LiNC-Ez™ software). The second modem and phone line is needed for the iAM panel. The third phone line is needed for the central station. Communication exists between the PC and the iAM panel. This is to download the parameters to the iAM panel. Communication also exists between the iAM panel and the Central Station. If a zone is tampered and an alarm is triggered, the iAM panel will automatically call the Central Station.



## 5.3 TCP/IP Communication (Optional LAN/Ethernet)

1. Connect a **Panel** to the **UDS-10** using the appropriate cable for the **DB25 Serial Port**.
2. Connect an **Ethernet cable** from the **PC** to the **10BaseT Port** and apply power to the unit.
3. Install **.NET Framework Version 1.1** (Win2000/XP/Server 2003 must install **.NET Framework Redistributable Package Version 1.1** prior to installing .NET Framework Version 1.1).
4. Install **Java Run Time Environment 1.4.2**.
5. Install **Lantronix Device Installer**.

6. Set up the static IP address for the PC by clicking on **Start** at the taskbar/**Control Panel/Network Communication**.
7. Right click on the LAN connection and select Properties. Find **Internet Protocols (TCP/IP)** and click on **Properties**.

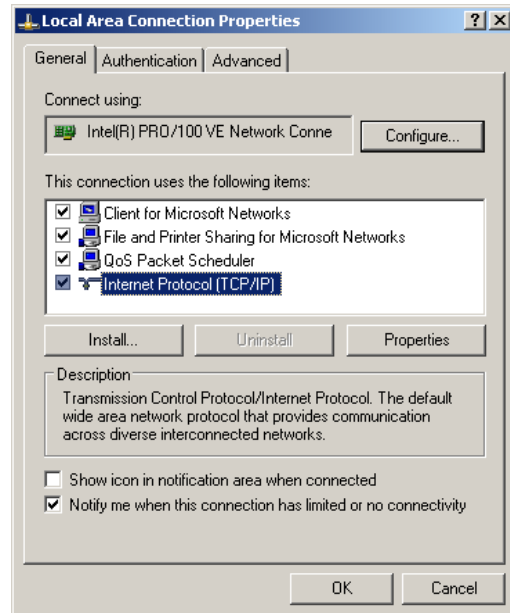

8. Select **Use the following IP address**. Set the **IP address** (ex. 192.168.168.25) and press **tab** on the keyboard to automatically set the **subnet mask**. Click on **OK**.

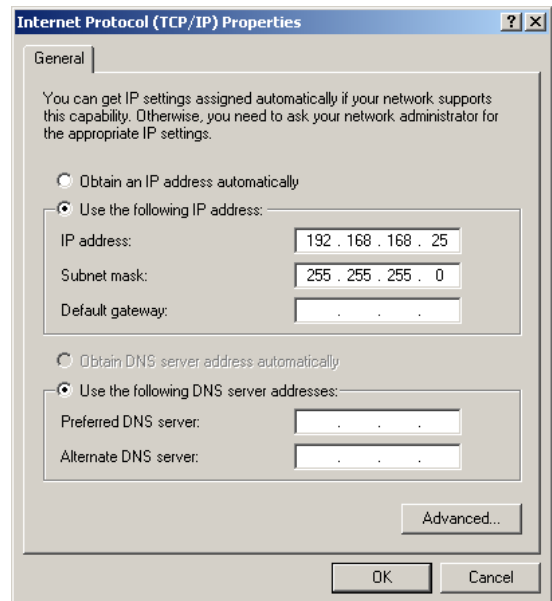

9. Click on **Start** on the taskbar and select **Programs/Lantronix/ DeviceInstaller**.

10. Click on **Search** to find the UDS device. The UDS-10 should be online.

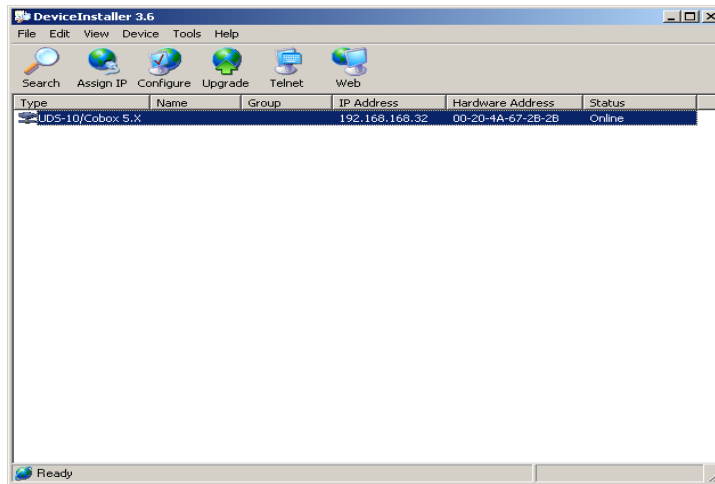

10. Click on the UDS-10 device and the toolbar (menu) should change.

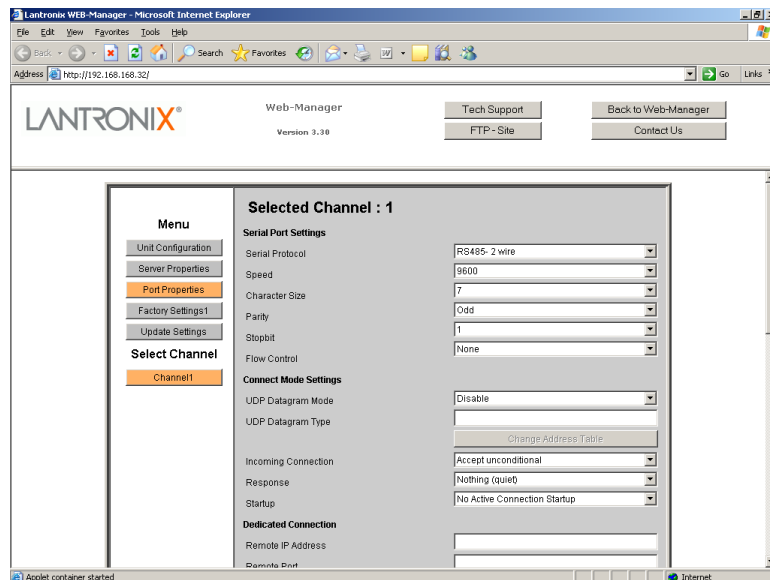

11. Click on **Web**. Change the port settings to **RS485-2 Wire** Serial Protocol, **9600** Speed, **7** Character Size, **Odd** parity, **1** Stop bit, and **None** for flow control. Also, set the local port to **3001**. Click on **Update Settings**, which is located on the left.

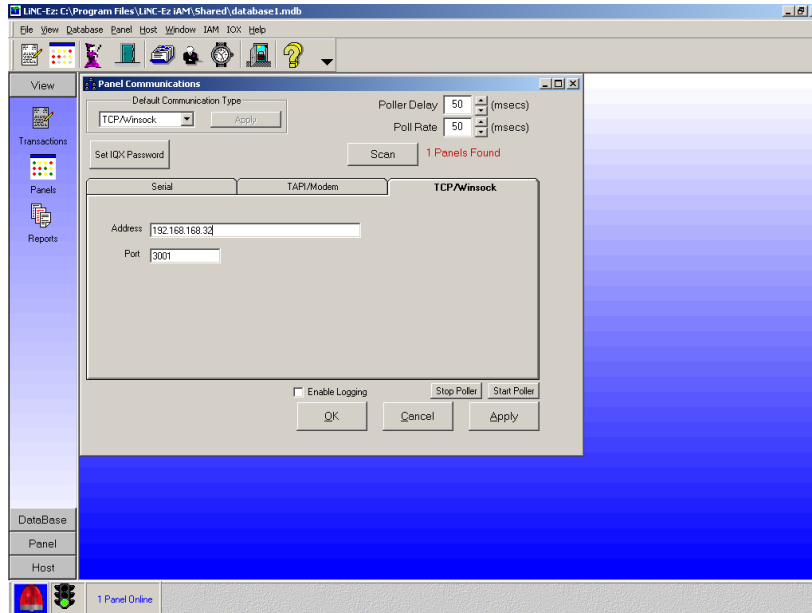

12. Open **LiNC-Ez iAM** and click on **Panel** at the top menu and select **Panel Communications**. Change the **Default Communication Type** from **Serial** to **TCP/Winsock** and click on **Apply**.
13. Select the **TCP/Winsock** tab and set the address and port number. The address is the same address that is seen in the DesignInstaller window for the UDS-10 device. The port is 3001. Click on apply. The panel should be online now.

### 5.3.1 Local Area Network Installation (IP Address Assignment)

Follow the Lantronix Terminal Server installation instructions. Make sure you note the UDS 10/100 IP Address and Port number. Program both the IP Address and the Port number in LiNC-Ez Panel Communication tab (section 5.2.3) and in the TCP/Winsock (section 5.3).

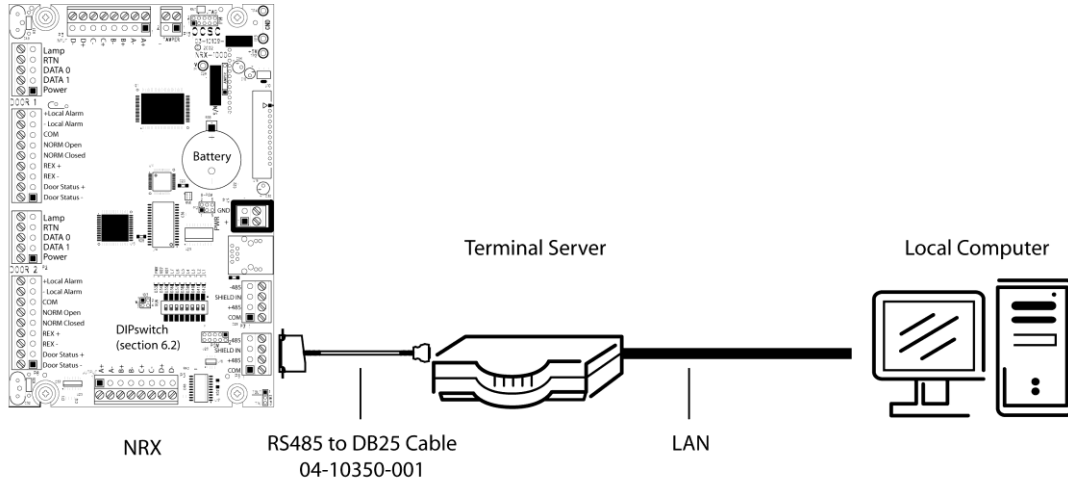

NRX/ Terminal Server IP Address \_\_\_\_\_ User IP Address \_\_\_\_\_

Port \_\_\_\_\_

### 5.3.2 Wide Area Network Installation (IP Address Assignment)

For WAN setup, follow the Lantronix Installation Instructions to setup communication to the terminal server. Give your IP Manager the IP Address and Port assignment. Your IP Manager should assign the UDS 10/100 port to your Public Router. Program both the IP Address and the Port number in LiNC-Ez Panel Communication tab (section 5.2.3) and in the TCP/Winsock (section 5.3).

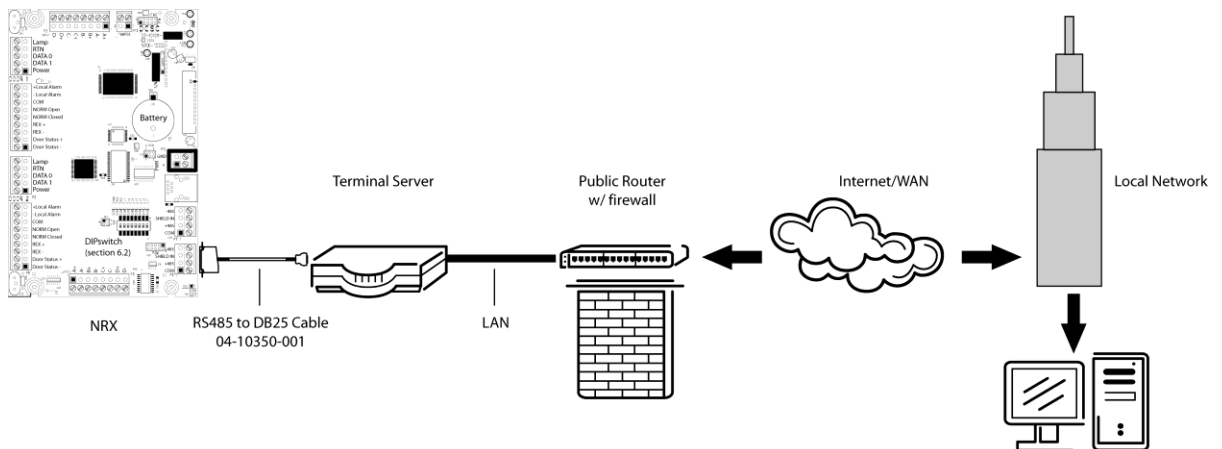

NRX/ Terminal Server IP Address \_\_\_\_\_ Public IP Address \_\_\_\_\_ User IP Address \_\_\_\_\_

Port \_\_\_\_\_

## 6.0 Appendix iAM Startup & Default Parameter

The iAM operates and can be changed or tested without LincEZ-iAM™ software. Programming, setup and testing can be performed through the Optex keypad. Administrative privilege is required.

Install iAM, Optex keypad, PCSC reader, door lock, REX switch, Zone sensors and bell as instructed in Installation Manual.

Upon first power up, the following default parameters exist. To RESET to default parameters, set iAM dip switch to zero and re-power. The iAM will take 20 seconds to reset all parameters. Change iAM dip switch back to #1. Battery Data backup requires iAM to be set to #1.

Once LincEZ-iAM™ communicates to iAM the parameter are set by LincEZ-iAM™.

**Before** the iAM has been linked to LincEZ-iAM™ setting are listed below:

<input type="checkbox"/> Cards #1-5 are Pre-Programmed ZoneGroup 2, Executive PIN holders	<input type="checkbox"/> Card #1 pin number is 0111; #2 is 0222; #3 is 0333; #4 is 0444; #5 is 0555
<input type="checkbox"/> Admin PIN number (password)	<input type="checkbox"/> <ent><ent><ent> 1, 2, 3, 4
<input type="checkbox"/> Date & Time	<input type="checkbox"/> 00:00:00 am & 01/01/2000
<input type="checkbox"/> 1-Zones 1-State (zones in uses)	<input type="checkbox"/> 1-8 Zone, 21-Out A(bell), 25 DRSTS (door) are Normal (in uses)
<input type="checkbox"/> 1-Zones 2-Calib	<input type="checkbox"/> All zones NOT supervised (can't calibrate)
<input type="checkbox"/> 1-Zones 3-Suprvs	<input type="checkbox"/> All zones NOT supervised
<input type="checkbox"/> 1-Zones 4-More 5-Latch	<input type="checkbox"/> All zones latched
<input type="checkbox"/> 1-Zones 4-More 6-Invert	<input type="checkbox"/> All zones normal (normal closed, alarm open)
<input type="checkbox"/> 2-ZGrps 1-Zones in ZGrp 1-Common Area	<input type="checkbox"/> 21-Out A (Bell), 25-DRSTS Door are in Common Area zone group
<input type="checkbox"/> 2-ZGrps 1-Zones in ZGrp 2-Zone Group 02	<input type="checkbox"/> 1-8 Zone
<input type="checkbox"/> 2-ZGrps 1-Zones in ZGrp 3-99 Zone Group	<input type="checkbox"/> NO Zones in Groups
<input type="checkbox"/> 3-Alarms	<input type="checkbox"/> ***Depends on Installation uses of Zone 1-8***
<input type="checkbox"/> 4-More 5-Date 1-3(style)	<input type="checkbox"/> Changes Date
<input type="checkbox"/> 4-More 6-Time	<input type="checkbox"/> Enters Time of Day
<input type="checkbox"/> 4-More 7-Phone	<input type="checkbox"/> 1, (enter Central Station phone number)
<input type="checkbox"/> 4-More 8-More 9-Delay 1-Entry	<input type="checkbox"/> 20 seconds Entry Delay
<input type="checkbox"/> 4-More 8-More 9-Delay 2-Exit	<input type="checkbox"/> 20 seconds Exit Delay
<input type="checkbox"/> 4-More 8-More 1-Bell	<input type="checkbox"/> 255 (forever) Bell Durations
<input type="checkbox"/> 4-More 8-More 2-Keypad	<input type="checkbox"/> 20 second keypad time out
<input type="checkbox"/> 4-More 8-More 3-Admin 1-PIN	<input type="checkbox"/> 1, 2, 3, 4 (Administrative Keypad password)
<input type="checkbox"/> 4-More 8-More 3-Admin 2-SiteCode	<input type="checkbox"/> 16383 (card site code)
<input type="checkbox"/> 4-More 8-More 3-Admin 3-Account	<input type="checkbox"/> 1234 (iAM Central Station Identity)

**End of Manual  
May 2006**