

**USER MANUAL**  
**AGILENT ACQIRIS**  
**8-BIT DIGITIZERS**

For Use with DP and DC Series Digitizers

Models covered:

DP105 / DP106 / DP110 / DP111 / DP210 / DP211 / DP212  
DP214 / DP235 / DP240 / DP1400 / DC110 / DC135 / DC140  
DC211 / DC211A / / DC241 / DC241A / DC271 / DC271A / DC271AR  
DC240 / DC265 / DC270  
U1061A / U1063A / U1064A / U1067A / U1068A / U1069A / U1071A  
U1084A / U1091A

NOTICE: In August 2014, Agilent Technologies' former Test and Measurement business became Keysight Technologies. This document is provided as a courtesy but is no longer kept current and thus will contain historical references to Agilent. For more information, go to **[www.keysight.com](http://www.keysight.com)**.



**Manual Part Number**

U1092-90001

**Edition**

I-Rev: I, May 2012

The information in this document is subject to change without notice and may not be construed in any way as a commitment by Agilent Technologies, Inc. While Agilent makes every effort to ensure the accuracy and contents of the document it assumes no responsibility for any errors that may appear.

All software described in the document is furnished under license. The software may only be used and copied in accordance with the terms of license. Instrumentation firmware is thoroughly tested and thought to be functional but it is supplied "as is" with no warranty for specified performance. No responsibility is assumed for the use or the reliability of software, firmware or any equipment that is not supplied by Agilent or its affiliated companies.

You can download the latest version of this manual from <http://www.agilent.com/> by clicking on Manuals in the Technical Support section and then entering a model number. You can also visit our web site at <http://www.agilent.com/find/acqiris> and download the latest manuals or software from the Technical Support section. At Agilent we appreciate and encourage customer input. If you have a suggestion related to the content of this manual or the presentation of information, please contact your local Agilent Acqiris product line representative or the dedicated Agilent Acqiris Technical Support ([ACQIRIS\\_SUPPORT@agilent.com](mailto:ACQIRIS_SUPPORT@agilent.com)).

**Acqiris Product Line Information**

USA (800) 829-4444

Asia - Pacific 61 3 9210 2890

Europe 41 (22) 884 32 90

© Copyright Agilent 2012

Adobe® and Acrobat® are trademarks of Adobe Systems Incorporated.

Windows® is a U.S. registered trademark of Microsoft Corporation.

MATLAB® is a registered trademark of The MathWorks, Inc.

## CONTENTS

<b>1. OUT OF THE BOX</b>	<b>5</b>
1.1. Message to the User	5
1.2. Using this Manual	5
1.3. Conventions Used in This Manual	5
1.4. Model Names	6
1.5. Disclaimer and Safety	6
1.6. Warning Regarding Medical Use	6
1.7. Packaging and Handling	7
1.8. Warranty	7
1.9. Warranty and Repair Return Procedure, Assistance and Support	7
1.10. Transport & Shipping	8
1.11. Maintenance	8
1.12. Cleaning	8
1.13. Disposal and Recycling	8
<b>2. INSTALLATION</b>	<b>9</b>
2.1. System Requirements	9
2.2. Installing the Software under Windows	9
2.2.1. U10xx Digitizer Products Support	10
2.3. Installing the Software for Linux	11
2.4. Installing the Hardware	11
2.5. Uninstalling devices under Windows	11
<b>3. PRODUCT DESCRIPTION</b>	<b>12</b>
3.1. Digitizer Overview	12
3.2. Channel Input	13
3.2.1. Coupling	13
3.2.2. Impedance	13
3.2.3. Input Protection	13
3.2.4. Mezzanine Front-end	13
3.2.5. Bandwidth and Rise Time	13
3.2.6. Input Voltage and Offset	16
3.2.7. Vertical Resolution	16
3.2.8. DC Accuracy and Linearity	16
3.2.9. Using Probes	16
3.3. Data Acquisition	17
3.3.1. Sampling Rate	18
3.3.2. Acquisition Memory	18
3.3.3. Single and Sequence Acquisition Modes	18
3.3.4. U1071A-FAMILY and U1084A Simultaneous multibuffer Acquisition and Readout (SAR)	19
3.3.5. Timing	19
3.3.6. Timebase Range	19
3.3.7. Combining channels	20
3.3.8. Sparkle Code Rate	20
3.3.9. U1084A Zero-Suppress Mode	20
3.4. Trigger	22
3.4.1. Trigger Source	22
3.4.2. Trigger Coupling	22
3.4.3. Trigger Level	22
3.4.4. Edge Trigger Slope	23
3.4.5. Window Trigger	23
3.4.6. HF Trigger	23
3.4.7. Spike Stretcher	23
3.4.8. U1071A-FAMILY and U1084A Multi-source Trigger	23
3.4.9. Pre- and Post-Trigger Delay	23
3.4.10. Trigger Status	24
3.5. External Clock and Reference	24

3.6.	Internal Calibration .....	24
3.7.	Factory Calibration.....	25
3.8.	AS bus .....	25
3.8.	Special Front Panel Input and Output (U1071A, DC271-FAMILIES and U1084A).....	26
3.8.1.	Multi-Purpose Input and Outputs (I/O A, B, C) .....	26
3.8.2.	TRIGOUT .....	26
3.9.	External Trigger Output (U1071A & DC271-FAMILIES and U1084A) .....	27
3.10.	Frequency Counter mode .....	27
3.11.	Electrical, Environmental and Physical Specifications .....	28
3.11.1.	Electrical .....	28
3.11.2.	Environmental and Physical.....	29
<b>4.</b>	<b>SOFT FRONT PANEL (SFP) APPLICATIONS.....</b>	<b>30</b>
4.1.	SFP Versions .....	30
4.1.1.	SFP 5.x .....	30
4.1.2.	SFP 1.x .....	30
4.2.	SFP Documentation.....	30
<b>5.</b>	<b>APPENDIX A: U1093A (U1056A) AS BUS FOR COMPACTPCI/PXI DIGITIZERS .....</b>	<b>31</b>
<b>6.</b>	<b>APPENDIX B: U1093A-AS6 (U1056A-A06) AS BUS 2 FOR PCI DIGITIZERS .....</b>	<b>32</b>
<b>7.</b>	<b>APPENDIX C: -BB1 BATTERY BACKUP FOR COMPACTPCI DIGITIZERS .....</b>	<b>33</b>
<b>8.</b>	<b>APPENDIX D: U1092A-HVB XA100 BNC INPUT OVERVOLTAGE PROTECTION .....</b>	<b>35</b>
<b>9.</b>	<b>APPENDIX E: U1091AX01 XP100 FAN UNIT FOR DP1XX/DP2XX UNITS .....</b>	<b>36</b>
<b>10.</b>	<b>APPENDIX F: XP101 FAN UNIT FOR DP DIGITIZERS (OBSOLETE).....</b>	<b>37</b>
<b>11.</b>	<b>APPENDIX G: U1091AX03 XP103 FAN UNIT FOR THE DPXXX MODULES.....</b>	<b>38</b>
<b>12.</b>	<b>APPENDIX H: U1091AX04 XP104 FAN UNIT FOR U1071A-FAMILY .....</b>	<b>39</b>
<b>13.</b>	<b>APPENDIX I: U1071A-XP5(U1091AX105) XP105 FAN UNIT FOR U1071A-FAMILY .....</b>	<b>41</b>
<b>14.</b>	<b>APPENDIX J: U1084A FAN UNIT .....</b>	<b>42</b>

# 1. Out of the Box

## 1.1. Message to the User

Congratulations on having purchased an Agilent Technologies Acqiris data conversion product. Acqiris digitizers are high-speed data acquisition modules designed for capturing high frequency electronic signals. To get the most out of the products we recommend that you read this manual carefully. We trust the product you have purchased will meet with your expectations and provide you with a high quality solution to your data conversion applications.

## 1.2. Using this Manual

This guide assumes you are familiar with the operation of a personal computer (PC) running a Windows 2000/XP/Vista/7 (32/64) or other supported operating system. It also assumes you have a basic understanding of the principles of data acquisition using either a waveform digitizer or a digital oscilloscope.

The manual is divided into 5 separate sections. To understand the elements of operation for the module it is essential that you read them all.

- Chapter 1 **OUT OF THE BOX**, describes what to do when you first receive your new Acqiris product. Special attention should be paid to sections on safety, packaging and product handling.
- Chapter 2 **INSTALLATION**, covers all elements of installation and performance verification. Before attempting to use your Acqiris product for actual measurements we strongly recommend that you read all sections of this chapter.
- Chapter 3 **PRODUCT DESCRIPTION**, provides a full description of all the functional elements of the digitizer.
- Chapter 4 **RUNNING THE AGILENT Soft Front Panel applications**, describes the usage of the MD1 SFP applications.

For information necessary for writing your own software to control Acqiris products you should refer to the **Programmer's Guide** and the **Programmer's Reference Manual**.

## 1.3. Conventions Used in This Manual

The following conventions are used in this manual:



This icon to the left of text warns that an important point must be observed.

**WARNING** Denotes a warning, which advises you of precautions to take to avoid being electrically shocked.

**CAUTION** Denotes a caution, which advises you of precautions to take to avoid electrical, mechanical, or operational damage.

**NOTE** Denotes a note, which alerts you to important information.

*Italic* text denotes a warning, caution, or note.

**Bold Italic** text is used to emphasize an important point in the text or a note

**mono** text is used for sections of code, programming examples and operating system commands.

B,KB,MB,GB is for Byte, KiloByte = 1024 bytes, MegaByte = 1024\*1024 bytes, GigaByte = 1024\*1024\*1024 bytes

Certain features are common to several different modules. For increased readability we have defined the following families:

DC271-FAMILY      U1061A/U1064A/U1069A      DC135/DC135HZ/DC140/DC140HZ/DC211/  
DC211A/DC241/DC241A/DC271/DC271A/  
DC271AR/DP214/DP235/DP240

U1071A-FAMILY      all U1071A variants, DP1400, U1091AD28

## 1.4. Model Names

Agilent Technologies Inc. acquired Acqiris SA and its product lines in December 2006. Use the tables below to cross reference new Agilent numbers with options to the legacy model name. The legacy model name is what is used in the Acqiris applications and the API.

Agilent Model Number	Acqiris Model Name
U1061A-001-F50	DC135
U1061A-001-FHZ	DC135HZ
U1061A-002-F50	DC140
U1061A-002-FHZ	DC140HZ
U1063A-001	DC265
U1063A-002	DC270
U1064A-001-F50	DC211
U1064A-001-FHZ	DC211A
U1064A-002-F50	DC241
U1064A-002-FHZ	DC241A
U1064A-004-F50	DC271
U1064A-004-FHZ	DC271A
U1067A-001	DP105
U1067A-002	DP110
U1068A-001	DP210
U1068A-002	DP211
U1069A-001	DP214
U1069A-002	DP235
U1069A-003	DP240
U1071A-001-F50	DP1400
U1071A-001-FHZ	U1071AHZ1
U1071A-002-F50	U1071A002
U1071A-002-FHZ	U1071AHZ2
U1071A-004-F50	U1071A004
U1071A-004-FHZ	U1071AHZ4
U1091A	DC110
U1091A	DP106
U1091A	DP212

Acqiris Model Name	Agilent Model Number
DC110	U1091A
DC135	U1061A-001-F50
DC135HZ	U1061A-001-FHZ
DC140	U1061A-002-F50
DC140HZ	U1061A-002-FHZ
DC211	U1064A-001-F50
DC211A	U1064A-001-FHZ
DC241	U1064A-002-F50
DC241A	U1064A-002-FHZ
DC265	U1063A-001
DC270	U1063A-002
DC271	U1064A-004-F50
DC271A	U1064A-004-FHZ
DP105	U1067A-001
DP106	U1091A
DP110	U1067A-002
DP210	U1068A-001
DP211	U1068A-002
DP212	U1091A
DP214	U1069A-001
DP235	U1069A-002
DP240	U1069A-003
DP1400	U1071A
U1071A002	U1071A-002-F50
U1071A004	U1071A-004-F50
U1071AHZ1	U1071A-001-FHZ
U1071AHZ2	U1071A-002-FHZ
U1071AHZ4	U1071A-004-FHZ

## 1.5. Disclaimer and Safety

The DP Series PCI digitizer cards have been designed to operate in a standard PCI slot found inside most personal computers. The model DC Series CompactPCI/PXI digitizers have been designed to operate inside a CompactPCI/PXI crate. The crate provides the modules with all needed power. Agilent does not recommend operation of the DC Series modules outside of a CompactPCI/PXI crate.



**CAUTION:** *Do not exceed the maximum input voltage rating! The maximum input voltage for 50  $\Omega$  input impedance is  $\pm 5$  V. The maximum input for 1 M $\Omega$  input impedance is  $\pm 100$  V (dc + ac) except for the DC2x1A/AR models where it is  $\pm 300$  V (dc + ac).*

## 1.6. Warning Regarding Medical Use

The Digitizer cards are not designed with components and testing procedures that would ensure a level of reliability suitable for use in treatment and diagnosis of humans. Applications of these cards involving medical or clinical treatment can create a potential for accidental injury caused by product failure, or by errors on the part of the user. These cards are *not* intended to be a substitute for any form of established process or equipment used to monitor or safeguard human health and safety in medical treatment.



**WARNING:** *The modules discussed in this manual have not been designed for making direct measurements on the human body. Users who connect an Acqiris module to a human body do so at their own risk.*

## 1.7. Packaging and Handling

Your Digitizer is shipped with the following components:

- A compact disc in an Agilent Technologies paper CD envelope that includes
  - Product User Manuals in electronic form.
  - 1 Programmer's Guide and 1 Programmer's Reference Manual in electronic form,
  - device drivers with sample software for different operating systems, environments and languages,
  - the SFP applications, a demonstration program for our digitizer and averager products,
  - full installation procedures for use with Microsoft Windows, IVI-COM/C, and Linux software.
- For many products a declaration of conformity is still included. However, in an increasing number of cases the Declaration can be viewed at <http://www.agilent-pra.com>.
- Optional documentation such as a model-dependent document giving Specifications & Characteristics, a Calibration Certificate, or a Performance Verification

After carefully unpacking all items, inspect each to ensure there are no signs of visible damage. Also check that all the components received match those listed on the enclosed packing list. Agilent cannot accept responsibility for missing items unless we are notified promptly of any discrepancies. If any items are found to be missing or are received in a damaged condition please contact the Agilent service center or your local supplier immediately. Retain the box and packing materials for possible inspection and/or reshipment.

## 1.8. Warranty

All Agilent Acqiris Digitizer products are warranted to operate within specification, assuming normal use, for a period of at least one year from the date of shipment. Units sold before April 2008 had three year warranties, as do some more recent ones; in case of doubt examine your invoice. It is recommended that yearly Factory Calibration be made in order to verify product performance. All repairs, replacement and spare parts are warranted for a period of 3 months. Warranty extensions are available as an option.

Agilent endeavors to provide leading edge technology that includes the latest concepts in hardware and software design. As such software and firmware used with the products is under continual refinement and improvement. All software and instrument firmware is supplied "as is" with no warranty of any kind. Software and firmware is thoroughly tested and thought to be functional at the time of shipment. At Agilent's discretion software and firmware may be revised if a significant operational malfunction is detected.

In exercising this warranty, Agilent will repair or replace any product returned to the Agilent service center, within the warranty period. The warranty covers all defects that are a result of workmanship or materials. This excludes defects that are caused by accident, misuse, neglect, or abnormal operation.

The purchaser is responsible for returning the goods to the nearest Agilent service center. This includes transportation costs and insurance. Agilent will return all warranty repairs with transportation prepaid.

## 1.9. Warranty and Repair Return Procedure, Assistance and Support

Agilent acquired Acqiris SA and its product lines in December 2006. Please contact your nearest Agilent Service Center before returning any product for repair.

You can find information about technical and professional services, product support, and equipment repair and service on the Web, see <http://www.agilent.com/find/service> (or <http://www.agilent.com/> and after selecting your country click on **Contact Us**). The service center will ask for your name, company, phone number and address, the model and serial numbers of the unit to be repaired, and a brief description of the problem.

Before issuing a Service Order the service center may ask you to communicate with us by phone or eMail so that we can learn as much as needed about the problems observed. If a unit returned under guarantee is found to be working normally and this procedure was not followed we reserve the right to charge you for the work done.

For your nearest customer support center please contact Acqiris Technical Support ([ACQIRIS\\_SUPPORT@agilent.com](mailto:ACQIRIS_SUPPORT@agilent.com)) or come visit our web site at <http://www.agilent.com/find/acqiris>. Alternatively, contact Acqiris at 1-800-829-4444 in the USA, +41 22 884 32 90 in Europe or +61 3 9210 2890 in the Asia-Pacific region. The Agilent Support Centers can also help redirect you for any questions concerning the installation and operation of your equipment.



## 1.10. Transport & Shipping



**CAUTION:** Cards can be safely transported in their original shipping packages. DC cards can be transported when properly mounted in a CompactPCI crate. The transport of DP cards mounted in a PC is a more delicate issue. Because of their mass the cards can vibrate loose unless they are properly secured and braced. DP cards held only in the front and on the bottom should not be shipped in their PC. However, properly mounted DP cards with XP103 or XP105 fans can be sufficiently well held; the Adjustable retainer must be used so as to hold the card in place.

To package the instrument for shipping:

### Step

1. Place the instrument in its original packaging materials.
2. Surround the instrument with at least 3 to 4 inches (8 to 10 cm) of its original packing material or bubble-pack to prevent the instrument from moving in its shipping container.
3. After wrapping it with packing material, place the instrument in its original shipping container or a strong shipping container that is made of double-walled corrugated cardboard with 159 kg (350 lb) bursting strength.
4. Seal the shipping container securely with strong nylon adhesive tape.
5. Mark the shipping container "FRAGILE, HANDLE WITH CARE" to help ensure careful handling.
6. Use the address obtained from your Agilent Service Center.
7. Retain copies of all shipping papers.

### Notes

- If the original packaging materials are not available, use a professional packaging service. Contact your Agilent Service Center for more information.
- The shipping container must be large and strong enough to accommodate your instrument and allow at least 3 to 4 inches (8 to 10 cm) on all sides for packing material.



**CAUTION:** Damage can result if the original packaging materials are not used. Packaging materials should be anti-static and cushion the instrument on all sides. NEVER USE STYRENE PELLETS IN ANY SHAPE AS PACKAGING MATERIALS. They do not adequately cushion the instrument or prevent it from moving in the shipping container. Styrene pellets can also cause equipment damage by generating static electricity or by lodging in fan motors.

## 1.11. Maintenance

The cards do not require any maintenance. There are no user serviceable parts inside. A periodic Factory Calibration can be obtained on request.

## 1.12. Cleaning

Cleaning procedures consist only of exterior cleaning.

Clean the exterior surfaces of the module with a dry lint-free cloth or a soft-bristle brush. If any dirt remains, wipe with a cloth moistened in a mild soap solution. Remove any soap residue by wiping with a cloth moistened with clean water. Do not use abrasive compounds on any parts.

## 1.13. Disposal and Recycling

Electronic equipment should be properly disposed of. Acqiris digitizers and their accessories must not be thrown out as normal waste. Separate collection is appropriate and may be required by law.



## 2. Installation

This chapter describes how to install the hardware and software for Windows and Linux.



**NOTE:** For a first time installation we strongly recommend installing the software **before** inserting the hardware into the PC.

### 2.1. System Requirements

The following table lists the system configurations that Agilent have tested, and are therefore guaranteed to work. In general, any x86 or x64 (except Itanium) processor should work, but there may be a decrease in performance.

Topic	System Requirements		
	Windows XP SP3	Windows Vista® SP1 and SP2, Windows 7® (32 or 64-bit), All versions.	Linux kernel 2.6 or higher (32 or 64-bit), Debian 6.0, CentOS 5
Processor speed	600 MHz or higher required 800 MHz recommended	1 GHz 32-bit (x86) or 64-bit (x64), no support for Itanium64	As per the minimum requirements of the chosen distribution.
Available memory	256 MB minimum (1 GB or greater recommended)	1 GB minimum	As per the minimum requirements of the chosen distribution.
Available disk space <sup>1</sup>	1.5 GB storage space, which includes: 1 GB available for Microsoft .NET Framework 3.5 SP1 <sup>2</sup>		100 MB
Video	SuperVGA (800x600) 256 colors or greater	Support for DirectX 9 graphics with 128 MB graphics memory recommended (SuperVGA graphics is supported)	Does not require graphics (headless system). X Windows with 1280x1024 recommended for SFP
Browser	Microsoft Internet Explorer 6.0 or later	Microsoft Internet Explorer 7 or later	Distribution supplied browser

**LabVIEW:** Full driver implementations are available for National Instruments LabVIEW versions 8.5, 8.2.1, and 8.0. LabVIEW 7.1 is frozen at the level of Acqiris Software 3.2 with support for all instruments.

**MATLAB:** The MEX interface can be used with MathWorks MATLAB 7.3 or a newer version.

**Visual C++:** The interface files, projects and examples are available for Microsoft Visual Studio 2008 / C++.

### 2.2. Installing the Software under Windows

The software is located on the Agilent MD1 High-Speed Digitizer Software and Product Information CD (M9210-90007). This software is also available for download at the Agilent website [www.agilent.com/find/Digitizers](http://www.agilent.com/find/Digitizers)

For a first time installation on your computer Agilent recommends that you install the software BEFORE installing the hardware on your system. When upgrading to a new version, you should leave your modules installed and powered during installation. Administrator privileges will be needed for software and hardware installation. This includes the case of first-time installation of a module in a different crate slot.

It is good practice to remove any previously installed version of the same Agilent software. However if the installation program finds that there is a conflict with software already installed on your machine a warning panel will appear.

<sup>1</sup> Note: Less storage space may be required for operation than is required for installation due to the process.

<sup>2</sup> Note: .NET Framework Runtime components are installed by default with Windows Vista. Therefore, you may not need this amount of available storage space.

## Installation procedure:

1. From the Agilent MD1 High-Speed Digitizer Software and Product Information CD (M9210-90007) launch the installer.

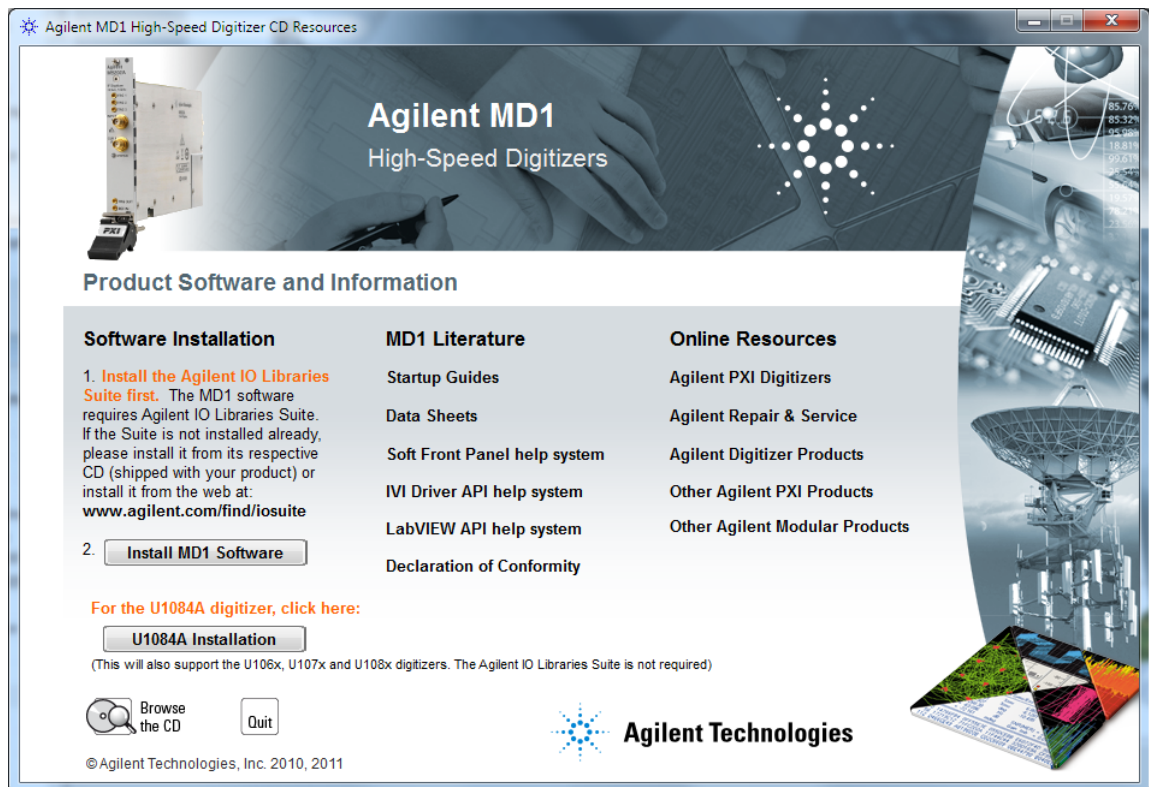

2. The 'U1084A Installation' button provides the option to install the U10xx Digitizer products package to your PC. This includes Device drivers, Soft Front Panel applications and documentation for the Agilent Acqiris 8-Bit digitizer products which are covered by this manual.
3. After installation is complete, re-start the PC and install the hardware, or the chassis and the host PC if you are using a remote controller.

### 2.2.1. U10xx Digitizer Products Support

If the 'U1084A Installation' option has been selected during the installation process the following items will have been installed to your PC:

- **Drivers** : IVI-C, IVI-COM, and LabVIEW G for all modules.
- **Documentation** : A folder `..\Program Files\Agilent\U10xx_Digitizers>manuals` will be created.
- **Agilent MD1 Soft Front Panel 1.7** : This version specifically supports the U10xx Digitizer products and replaces the previous 'AcqirisLive' application, its functions and operation are virtually identical.
- **Examples** : For MatLab, C++, LabVIEW will be placed into the `..\Program Files\Agilent\U10xx_Digitizers` folder in the appropriate sub-folder.

## 2.3. Installing the Software for Linux

Please refer to the README file in the /Linux folder of the Software CD-ROM for detailed instructions on how to install the software for Linux systems.

## 2.4. Installing the Hardware

1. Turn off the power of the PC and the crate in the case of a CompactPCI module.



**CAUTION:** For PCI modules the PC may have to be unplugged to ensure that the PCI bus has no power available. However, CompactPCI crates can be left plugged in since this ensures proper grounding.



**CAUTION:** Touch the antistatic package to a grounded object before removing the card from the package. Electrostatic discharge may damage the card.

*Be sure to ground yourself by touching the grounded frame and avoid touching any components on the card.*

2. Module in a PC: open the PC, identify a free PCI slot and carefully insert the card into it. Make sure that the grounding of the card's mounting bracket to the back panel rail of the computer is done correctly. If present make sure that the fan's adjustable retainer is correctly positioned and tightened for mechanical support. Close the PC.

Module in a CompactPCI crate: Follow the instructions of the crate manufacturer to insert the card into a free CompactPCI peripheral slot. Be sure to tighten both front panel mounting screws to lock the module into place and insure proper grounding of the frame.



**NOTE:** To ensure the best possible performance, users of Agilent CC121 Crates with AS bus systems should respect the module placement rules to be found in the Agilent Acqiris 21-slot CompactPCI Crate User Manual.

PCI Bus extension module in a PC: Consult the manufacturer's documentation for any special instructions. Open the PC, identify a free PCI slot and carefully insert the card into it. Make sure that the grounding of the card's mounting bracket to the back panel rail of the computer is done correctly. Close the PC. Connect the module to the CompactPCI crate controller.

3. Turn on the power of the crate(s), if present, and then the PC and start the operating system.



**NOTE:** Agilent Acqiris digitizers are equipped with a LED. If this LED is not glowing orange or red when the power is applied there is a severe problem. Either the module is broken or the necessary voltages for its use are not available.



**NOTE:** For proper system operation when using the IC200, IC414, or other PCI extension interface to connect a CC10X crate to a remote PC, the crate **must** be powered on before the PC in order for the PC BIOS to recognize the presence of the CompactPCI crate.

## 2.5. Uninstalling devices under Windows

In the Device Manager, select the instrument to be uninstalled. Choose "Uninstall" from the "Action" menu. After all desired instruments have been uninstalled select "Scan for hardware changes" from the "Action" menu, or reboot the computer. Note that only those devices that are actually physically present are visible in the Device Manager.

### 3. Product Description

#### 3.1. Digitizer Overview

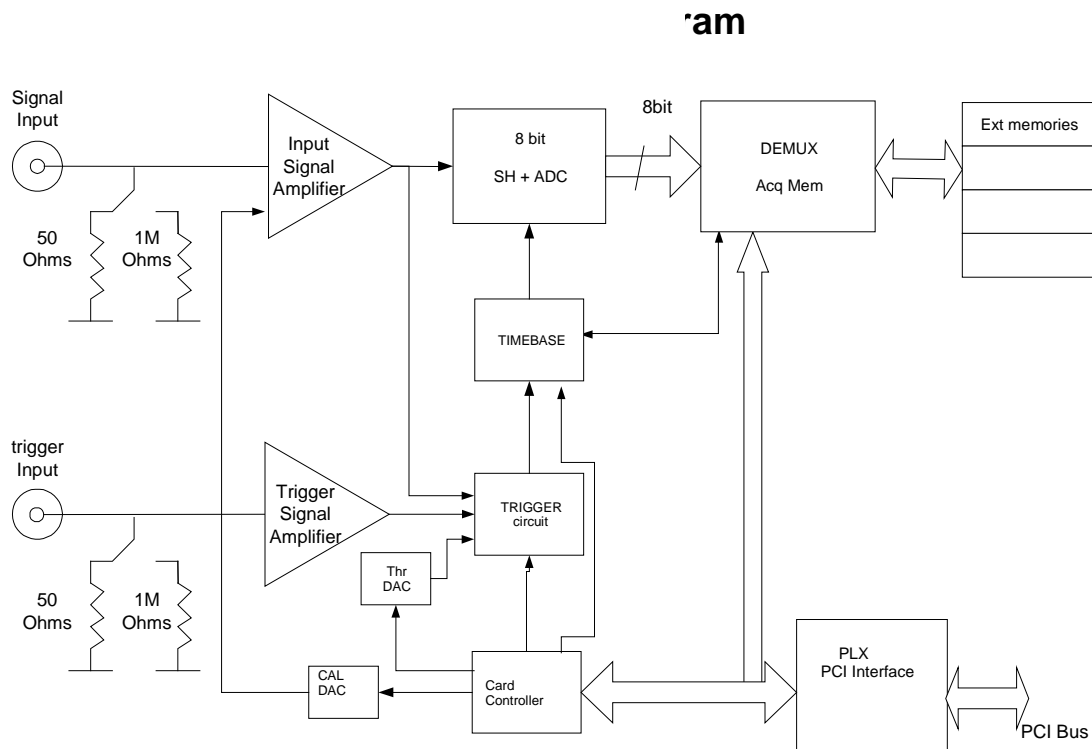

Agilent Acqiris digitizers are available in two popular industry standards. The DP series digitizers are PCI modules that plug directly into a vacant PCI slot in a PC (U1084A is PCIe). The PCI and PCIe Buses being a well-defined industry standard. The DC series products are CompactPCI/PXI compliant and require an appropriate CompactPCI crate. The digitizers are all fully programmable over the PCI bus and deliver oscilloscope-like performance. Data captured by the digitizers can be transferred to a host processor, either in the PC, in the crate, or interfaced to the crate, over the PCI bus using a 32-bit bus operating at 33 MHz, at speeds up to 520 MB/s for the U1084A PCIe x4 bus. The U1071A-FAMILY can use the PCI bus at 66 MHz thus allowing transfer rates up to 200 MB/s.

DC1XX series digitizers occupy a single slot of a 3U CompactPCI crate and they comply with the 3U Compact PCI standard (PXI compliant). DC2XX series digitizers occupy a single slot of a 6U CompactPCI crate and they comply with the 6U CompactPCI standard (PXI compliant).

Acqiris digitizers are designed to provide superior measurement precision and accuracy. Key acquisition specifications (such as DC accuracy, integral and differential non-linearity) have been optimized to deliver maximum measurement fidelity. Careful circuit layout, custom IC's and special packaging techniques have all been employed to reduce overall system noise. The use of custom IC's also dramatically reduces the total number of discrete components required. This has tremendous benefits on reliability and also allows the modules to use a minimal amount of power (15 W typical for a single channel 1 GS/s card).

The block diagram above is a simplified representation of a single channel unit. For complete technical specifications concerning your particular digitizer please refer to the product's Specifications & Characteristics. In addition, we maintain up-to-date versions of all product data sheets on our web site (<http://www.agilent.com/find/acqiris>). The data sheets are available in pdf format and are best viewed using Adobe Acrobat software. If you have trouble accessing our web site, or viewing the data sheets, please contact your nearest sales office.

## 3.2. Channel Input

### 3.2.1. Coupling

Both AC and DC coupling modes are available. The AC mode couples signals capacitively thus removing the input signal's DC component and filtering out any signal component below 16 Hz for the DC2x1A digitizers, 32 Hz for the DC271-FAMILY and 10 Hz for all other models. DC mode allows all signal components to be passed through to the digitizer.

### 3.2.2. Impedance

The input channels of the DP and DC Series digitizers offer termination into 50 Ω and, sometimes 1 MΩ. The 50 Ω coupling mode offers high quality termination with better than ± 1% precision. It is ideally suited to use with 50 Ω transmission lines (coax), high bandwidth low impedance (typically 500 Ω) probes, or active probes. The 1 MΩ coupling mode provides a high impedance (low load) capability that is suited for use with most standard high impedance probes. The high impedance mode also features low (typically ~10 pF, see table) capacitance that helps to minimize loading effects that can occur when probing high frequency circuits.

### 3.2.3. Input Protection

The input amplifiers are fully protected against over-voltage signals up to the levels shown in the table below:

Model / Family	Input	Maximum level	Conditions
DC271A, DC271AR, DC241A, DC211A	1 MΩ	±300 V	DC + peak AC < 10 KHz
U1071A-FHZ	50 Ω	±2.5 V DC	50 mV to 500 mV FS Ranges
	50 Ω	±5 V DC	1 V to 5 V FS Ranges
	1 MΩ	±300 V DC	
All other models	50 Ω	±5 V DC	
	1 MΩ	±100 V	DC + peak AC < 10 KHz

The front-end also provides an overload protection that will automatically switch the coupling from 50 Ω to 1 MΩ if the signal is greater than ±5 V DC. This is implemented for most modules (not the DC2x1A) that have the 1MΩ impedance possibility.

### 3.2.4. Mezzanine Front-end

The front-end electronics are all mounted on a removable mezzanine card. In the event of accidental damage, or as components fatigue over time (e.g. relays in high duty cycle automated testing applications), the mezzanine card allows for fast and efficient replacement.

### 3.2.5. Bandwidth and Rise Time

The bandwidth specification indicates the frequency at which an input signal will be attenuated by 3 dB (approximately 30% loss of amplitude). The bandwidth also affects the minimum rise and fall times that can be passed through the front-end electronics. A pulse with a very sharp edge will be observed to have a minimum rise time ( $\tau_{\min}$ ) determined by the front-end electronics. In general a pulse with a given 10-90% rise time ( $\tau_{10-90\text{real}}$ ) will be observed with a slower value given by:

$$\tau_{10-90}^2 = \tau_{10-90\text{real}}^2 + \tau_{\min}^2 \quad \text{where} \quad \tau_{\min} (\text{ns}) \approx 0.35 (\text{GHz-ns}) / \text{BW} (\text{GHz})$$

The following table indicates the bandwidth and rise time performance of the DP and DC Series digitizers. For many digitizers, the bandwidth can be limited with hardware bandwidth limiters as shown in the tables below. For many of the older models the bandwidth at 50 mV FS, BW<sub>50</sub>, is not as high as that of the other sensitivities.

Model Agilent #	Bandwidth into 50 $\Omega$	Bandwidth/ Capacitance into 1 M $\Omega$	Minimum Rise Time	BW Limiter selections	Maximum Offset	Other particularities
<b>DP105</b> U1067A-001	150 MHz	150 MHz 8 pF	2.3 ns	NA	20 V	BW <sub>50</sub> = 90 MHz
<b>DP106</b>	250 MHz	NA	1.4 ns	NA	NA	BW <sub>50</sub> = 200 MHz Max FS = 0.5 V
<b>DP110</b> U1067A-002	250 MHz	250 MHz 8 pF	1.4 ns	NA	20 V	BW <sub>50</sub> = 200 MHz
<b>DP111</b>	500 MHz	NA	0.7 ns	25 MHz	NA	BW <sub>50</sub> = 200 MHz Max FS = 0.5 V
<b>DP210</b> U1068A-001	500 MHz	400 MHz 8 pF	0.7 ns	NA	20 V	BW <sub>50</sub> = 200 MHz
<b>DP211</b> U1068A-002	500 MHz	NA	0.7 ns	25 MHz	NA	BW <sub>50</sub> = 200 MHz Max FS = 0.5 V
<b>DP212</b>	500 MHz	NA	0.7 ns	25 MHz	NA	BW <sub>50</sub> = 200 MHz Max FS = 0.5 V
<b>DP214</b> U1069A-001	1 GHz	NA	0.35 ns	20, 200, 700 MHz	5 V	DC271 FAMILY
<b>DP235</b> U1069A-002	500 MHz	NA	0.7 ns	20, 200 MHz	5 V	DC271 FAMILY
<b>DP240</b> U1069A-003	1 GHz	NA	0.35 ns	20, 200, 700 MHz	5 V	DC271 FAMILY
<b>DP1400</b> U1071A -001-F50	1 GHz	NA	0.35 ns	20, 200, 700 MHz	5 V	U1071A-FAMILY
<b>U1071A002</b> U1071A -002-F50	500 MHz	NA	0.7 ns	20, 200 MHz	5 V	U1071A-FAMILY
<b>U1071A004</b> U1071A -004-F50	150 MHz	NA	2.3 ns	20 MHz	5 V	U1071A-FAMILY
<b>U1071AHZ1</b> U1071A -001-FHZ	1 GHz	300 MHz typical 18 pF	0.35 ns (50 $\Omega$ ) (1.2 ns 1 M $\Omega$ )	20, 200, 700 MHz (see remark below)	5 V (50 $\Omega$ ) 20 V (> 0.5 V FS & 1M $\Omega$ ) 200 V (> 5V FS & 1M $\Omega$ )	U1071A-FAMILY Max FS = 50 V (1 M $\Omega$ )
<b>U1071AHZ2</b> U1071A -002-FHZ	500 MHz	300 MHz typical 18 pF	0.7 ns (50 $\Omega$ ) (1.2 ns 1 M $\Omega$ )	20, 200 MHz (see remark below)	5 V (50 $\Omega$ ) 20 V (> 0.5 V FS & 1M $\Omega$ ) 200 V (> 5V FS & 1M $\Omega$ )	U1071A-FAMILY Max FS = 50 V (1 M $\Omega$ )
<b>U1071AHZ4</b> U1071A -004-FHZ	150 MHz	150 MHz typical 18 pF	2.3 ns 50 $\Omega$ & 1 M $\Omega$	20 MHz	5 V (50 $\Omega$ ) 20 V (> 0.5 V FS & 1M $\Omega$ ) 200 V (> 5V	U1071A-FAMILY Max FS = 50 V (1 M $\Omega$ )

Model Agilent #	Bandwidth into 50 $\Omega$	Bandwidth/ Capacitance into 1 M $\Omega$	Minimum Rise Time	BW Limiter selections	Maximum Offset	Other particularities
					FS & 1M $\Omega$ )	
<b>U1084A</b>	1.5 GHz	n/a	230 ps	20, 200, 700 MHz	5 V (50 $\Omega$ )	BW <sub>50</sub> = 500 MHz
<b>U1091AD28</b>	500 MHz	NA	0.7 ns	20, 200 MHz	5 V	U1071A-FAMILY
<b>DC110</b> U1091A	250 MHz	250 MHz 8 pF	1.4 ns	NA	20 V	BW <sub>50</sub> = 200 MHz
<b>DC135</b> U1061A -001-F50	500 MHz	NA	0.7 ns	20, 200 MHz	5 V	DC271 FAMILY FC Option
<b>DC135HZ</b> U1061A -001-FHZ	500 MHz	300 MHz typical 18 pF	0.7 ns (50 $\Omega$ ) (1.2 ns 1 M $\Omega$ )	20, 200 MHz (see remark below)	5 V (50 $\Omega$ ) 20 V (> 0.5 V FS & 1M $\Omega$ ) 200 V (> 5V FS & 1M $\Omega$ )	DC271 FAMILY FC Option Max FS = 50 V (1 M $\Omega$ )
<b>DC140</b> U1061A -002-F50	1 GHz	NA	0.35 ns	20, 200, 700 MHz	5 V	DC271 FAMILY FC Option
<b>DC140HZ</b> U1061A -002-FHZ	1 GHz	300 MHz typical 18 pF	0.35 ns (50 $\Omega$ ) (1.2 ns 1 M $\Omega$ )	20, 200, 700 MHz (see remark below)	5 V (50 $\Omega$ ) 20 V (> 0.5 V FS & 1M $\Omega$ ) 200 V (> 5V FS & 1M $\Omega$ )	DC271 FAMILY FC Option Max FS = 50 V (1 M $\Omega$ )
<b>DC211</b> U1064A	1 GHz	NA	0.35 ns	20, 200, 700 MHz	5 V	DC271 FAMILY
<b>DC211A</b> U1064A	950 MHz ( 1 GHz typical)	300 MHz typical 14 pF	0.35 ns (50 $\Omega$ ) (1.2 ns 1 M $\Omega$ )	20, 200, 700 MHz (see remark below)	5 V (50 $\Omega$ ) 20 V (> 0.5 V FS & 1M $\Omega$ ) 200 V (> 5V FS & 1M $\Omega$ )	DC271 FAMILY Max FS = 50 V (1 M $\Omega$ )
<b>DC240</b>	500 MHz	400 MHz 11 pF	0.7 ns	NA	20 V	BW <sub>50</sub> = 200 MHz
<b>DC241</b> U1064A	1 GHz	NA	0.35 ns	20, 200, 700 MHz	5 V	DC271 FAMILY
<b>DC241A</b> U1064A	950 MHz ( 1 GHz typical)	300 MHz typical 14 pF	0.35 ns (50 $\Omega$ ) (1.2 ns 1 M $\Omega$ )	20, 200, 700 MHz (see remark below)	5 V (50 $\Omega$ ) 20 V (> 0.5 V FS & 1M $\Omega$ ) 200 V (> 5V FS & 1M $\Omega$ )	DC271 FAMILY Max FS = 50 V (1 M $\Omega$ )
<b>DC265</b> U1063A	150 MHz	150 MHz 11 pF	2.3 ns	NA	20 V	BW <sub>50</sub> = 90 MHz
<b>DC270</b> U1063A	250 MHz	250 MHz 11 pF	1.4 ns	NA	20 V	BW <sub>50</sub> = 90 MHz
<b>DC271</b> U1064A	1 GHz	NA	0.35 ns	20, 200, 700 MHz	5 V	DC271 FAMILY
<b>DC271A</b>	950 MHz ( 1 GHz	300 MHz typical	0.35 ns (50 $\Omega$ )	20, 200, 700 MHz (see remark below)	5 V (50 $\Omega$ ) 20 V (> 0.5 V	DC271 FAMILY Max FS = 50 V



Model Agilent #	Bandwidth into 50 $\Omega$	Bandwidth/ Capacitance into 1 M $\Omega$	Minimum Rise Time	BW Limiter selections	Maximum Offset	Other particularities
U1064A DC271AR	typical)	14 pF	(1.2 ns 1 M $\Omega$ )		FS & 1M $\Omega$ ) 200 V (> 5V FS & 1M $\Omega$ )	(1 M $\Omega$ ) The AR has only 2 channels

For 1 M $\Omega$  coupling in the DC2x1A/AR, DC140HZ, and U1071AHZ1 the 700 MHz Bandwidth Limiter cannot be used. Furthermore, in the DC2x1A/AR, DC1xxHZ, and U1071AHZn with FS gain > 5V the 200 MHz Bandwidth Limiter is always active.

### 3.2.6. Input Voltage and Offset

The input channel provides a fully programmable amplifier with variable input voltage and offset. Full Scale (FS) input voltages are selectable from 50 mV to 5 V (except as shown above) in a 1, 2, 5 sequence. Care should be taken to select an input voltage range that will allow the signal to be recorded using as much dynamic range of the digitizer as possible. The Variable Offset is programmable in the range of  $\pm 2$  V when using an FS Input Voltage setting of 500 mV or below, increasing to  $\pm$  Maximum Offset for FS settings above 500 mV. The raw 8-bit ADC data values are in the range [-128, +127] with the first and last values reserved for underflow and overflow respectively. The midpoint value, 0, of the range corresponds to the negative of the offset voltage. Thus the Full Scale Range (FSR) goes from

$$-\text{Offset Voltage} - (\text{FS}/2) \quad \text{to} \quad -\text{Offset Voltage} + (\text{FS}/2)$$

Signals going outside of the FSR will be clipped and data values for the clipped portion of a signal should be regarded as erroneous.

The maximum input voltage for 50  $\Omega$  input impedance is  $\pm 5$  V. The maximum input for 1 M $\Omega$  input impedance is  $\pm 100$  V (dc + ac) except for the DC2x1A/AR models where it is  $\pm 300$  V (dc + ac).

### 3.2.7. Vertical Resolution

The digitizers described in this manual use an ADC system with 8 bits of vertical resolution (256 levels). The dynamic range of the ADC covers the Full Scale Range (FSR) of the Input Voltage setting. For example, if the Input Voltage is set to 1 V then the ADC resolution is equivalent to 3.91 mV. To obtain the best dynamic range from the ADC care should be taken to ensure that the input signal varies over more than 50% of the Input Voltage FSR setting.

### 3.2.8. DC Accuracy and Linearity

The DP and DC Series digitizers use low noise front-end electronics in order to ensure voltage measurement is made with accuracy and precision. DC voltage accuracy, at 0 V offset, is better than  $\pm 2\%$  ( $\pm 1\%$  typical) of the input voltage full scale. The differential linearity is better than  $\pm 0.7$  LSB ( $\pm 0.8$  LSB for DC135/DC140 digitizers and  $\pm 0.9$  LSB for other DC271-FAMILY and U1084A digitizers).

### 3.2.9. Using Probes

The 50  $\Omega$  and 1 M $\Omega$  input impedance settings make it possible to use Acqiris digitizers with a wide variety of probes. The 50  $\Omega$  setting is most commonly used for active probes and low impedance (500  $\Omega$ ) passive probes. The 1 M $\Omega$  setting is normally used for high impedance probes. Before using any passive probe with a digitizer care should be taken to check that the probe has been correctly adjusted (refer to the Probe's Calibration procedure).

 **NOTE:** Passive high impedance probes are not suitable for high fidelity measurements above 100 MHz. The non-negligible (5-10 pF) tip capacitance loads the signal causing distortion and/or ringing when combined with the ground lead inductance.

### 3.3. Data Acquisition

The table below summarizes the characteristics discussed in the sections that follow:

Model	Max. Sample Rate	Max. Converters per channel / No Channels	Default Memory (Samples per channel)	Maximum Optional Memory (Samples per channel)	Maximum Segments	TTI Resolution	Timebase Accuracy	External Clock Min/Max Thresh.
<b>DP105</b>	500 MS/s	1 / 1	128 K	8 M	8000	80 ps	50 ppm	± 2 V
<b>DP106</b>	500 MS/s	1 / 1	128 K	2 M	4000	80 ps	50 ppm	± 2 V
<b>DP110</b>	1 GS/s	1 / 1	128 K	8 M	8000	80 ps	50 ppm	± 2 V
<b>DP111</b>	1 GS/s	1 / 1	128 K	2 M	4000	5 ps	2 ppm	± 3 V
<b>DP210</b>	2 GS/s	1 / 1	256 K	16 M	8000	5 ps	2 ppm	± 3 V
<b>DP211</b>	2 GS/s	1 / 1*	256 K	16 M	8000	5 ps	2 ppm	± 3 V
<b>DP212</b>	2 GS/s	1 / 1	256 K	16 M	8000	5 ps	2 ppm	± 3 V
<b>DP214</b>	2 GS/s	1 / 1	256 K	16 M	8000	5 ps	2 ppm	± 2 V
<b>DP235</b>	1 GS/s	2 / 2	128 K	2 M	4000	5 ps	2 ppm	± 2 V
<b>DP240</b>	2 GS/s	2 / 2	128 K	8 M	8000	5 ps	2 ppm	± 2 V
<b>DP1400</b> <b>U1071AHZ1</b>	2 GS/s	2 / 2	128 K	128 M	64000	~13ps	2 ppm	AC 0 V
<b>U1071A002</b> <b>U1071AHZ2</b>	2 GS/s	2 / 2	128 K	128 M	64000	~13ps	2 ppm	AC 0 V
<b>U1071A004</b> <b>U1071AHZ4</b>	1 GS/s	2 / 2	128 K	128 M	64000	~13ps	2 ppm	AC 0 V
<b>U1084A</b>		2 / 2				15 ps	2 ppm	± 2 V
-001	2-4 GS/s	“	-	-	-	“	“	“
-002	1-2 GS/s	“	-	-	-	“	“	“
-003	0.5-1 GS/s	“	-	-	-	“	“	“
-STD	-	“	256 M	256 M	131000	“	“	“
-256	-	“	128 M	256 M	65500	“	“	“
-128	-	“	64 M	256 M	32750	“	“	“
<b>U1091AD28</b>	2 GS/s	2 / 2	128 K	N/A	1000	~13ps	2 ppm	AC 0 V
<b>DC110</b>	1 GS/s	1 / 1	128 K	8 M	8000	5 ps	50 ppm	± 2 V
<b>DC135</b> <b>DC135HZ</b>	1 GS/s	2 / 2	64 K	2 M	4000	5 ps	2 ppm	± 2 V
<b>DC140</b> <b>DC140HZ</b>	2 GS/s	2 / 2	128 K	8 M	8000	5 ps	2 ppm	± 2 V
<b>DC211</b>	4 GS/s	1 / 1	512 K	32 M	8000	5 ps	2 ppm	± 2 V
<b>DC211A</b>	4 GS/s	1 / 1	128 K	8 M	8000	5 ps	2 ppm	± 2 V
<b>DC240</b>	2 GS/s	1 / 2	256 K	16 M	8000	5 ps	2 ppm	± 3 V
<b>DC241</b>	4 GS/s	2 / 2	256 K	16 M	8000	5 ps	2 ppm	± 2 V
<b>DC241A</b>	4 GS/s	2 / 2	128 K	8 M	8000	5 ps	2 ppm	± 2 V
<b>DC265</b>	500 MS/s	1 / 4	128 K	2 M	4000	5 ps	2 ppm	± 2 V
<b>DC270</b>	1 GS/s	1 / 4	128 K	8 M	8000	5 ps	2 ppm	± 2 V

Model	Max. Sample Rate	Max. Converters per channel / No Channels	Default Memory (Samples per channel)	Maximum Optional Memory (Samples per channel)	Maximum Segments	TTI Resolution	Timebase Accuracy	External Clock Min/Max Thresh.
DC271	4 GS/s	4 / 4	128 K	8 M	8000	5 ps	2 ppm	± 2 V
DC271A	4 GS/s	4 / 4	128 K	8 M	8000	5 ps	2 ppm	± 2 V
DC271AR	2 GS/s	2 / 2	128 K	8 M	8000	5 ps	2 ppm	± 2 V

The \* indicates a Dual Input module where there is one channel which can digitize the signal on one of the two BNC inputs

### 3.3.1. Sampling Rate

All Acqiris digitizers contain an analog-to-digital conversion (ADC) system that can sample waveforms, in a real time sampling mode, at rates from the maximum allowed rate down to 100 S/s (10 ms per point). The lowest allowed sampling rate for U1071A-FAMILY modules is set to 10 MS/s (except for U1071A which is 100 S/s), 488 KS/s for the U1084A. The sampling rate can be programmed and is selectable in a 1, 2, 2.5, 4, 5 sequence (i.e. 1 MS/s, 2 MS/s, 2.5 MS/s, 4 MS/s, 5 MS/s, 10 MS/s, ... 1 GS/s, 2GS/s, 4 GS/s). It is selectable from 4 GS/s down to 488 KS/s in binary steps (4 GS/s divided by 2<sup>n</sup>) for the U1084A. The maximum sampling rate shown above sometimes exploits the possibility of combining channels.

### 3.3.2. Acquisition Memory

Data from the ADC is stored in on-board acquisition memory. The amount of memory in use for acquisition can be programmed and is selectable from 1 point to the full amount of acquisition memory available.

For technical reasons, a certain memory “overhead” is required for each waveform, reducing the available memory by a small amount. In order to simplify programming, an interface function recommends the best sampling rate and the maximum possible number of data points, taking into account the available memory, the requested time window, the number of segments (in Sequence mode), as well as the required memory overhead.

To ensure maximum sampling rate and high timing resolution, we strongly recommend the use of long acquisition memories whenever possible. For example, the model DC110 or DP110 with 2 Mpoints of memory can record a signal over a 2 ms period with a sampling rate of 1 GS/s (1 ns per point). The fast sampling rate ensures that all high frequency signal components, up to the full 250 MHz bandwidth of the digitizer, are accurately recorded. If the memory were reduced to just 20 Kpoints then the sampling rate would need to be reduced to just 10 MS/s (20,000/2 ms) to record the same 2 ms period. All frequencies above 5 MHz would then be incorrectly digitized and important signal characteristics may be distorted or even completely missed.

Furthermore, to avoid potential timeout issues when using a very small acquisition size, the minimum acquisition length is 100 samples for each segment or single acquisition, per channel. i.e the minimum number of samples for a 2-channel interleave will be 200, and for a 4-channel interleave it will be 400 samples.

### 3.3.3. Single and Sequence Acquisition Modes

Digitizers acquire waveforms in association with triggers. Each waveform is made of a series of measured voltage values (sample points) that are made by the ADC at a uniform clock rate. To maximize sampling rates and utilize memory as efficiently as possible, the digitizers include both Single and Sequential storage modes. For both of these modes the data of all of the active channels is acquired synchronously; all of the ADC’s are acquiring data at the same time, to within a small fraction of the maximum sampling rate.

The Single Acquisition mode is the normal operation of most digitizer products. In this mode an acquisition consists of a waveform recorded with a single trigger. The user selects the sampling rate and acquisition memory size and sets the number of segments to 1 (default value).

The Sequence Acquisition mode allows the capture and storage of consecutive “single” waveforms. Sequence Acquisition mode is useful as it can optimize the digitizer’s sampling rate and memory requirements for applications where only portions of the signal being analyzed are important. The mode is extremely useful in almost all impulse-response type applications (RADAR, SONAR, LIDAR, Time-of-Flight, Ultrasonics, Medical and Biomedical Research, etc.).

In Sequence Acquisition mode the acquisition memory is divided into a pre-selected number of segments. Waveforms are stored in successive memory segments as they arrive. Each waveform requires its own individual trigger. For most modules the memory can be divided into any number of segments between 2 and 200 (up to 8000 segments with options M32, M16, M8M and M4M, 4000 segments with option M2M, 2000 with option M1M). The U1071A-FAMILY can have up to 1000 segments for the standard memory and up to 64000 with option -256. The U1084A has up to 64000 segment as standard. In Sequence Acquisition mode the user needs to specify the sampling rate, the total acquisition memory, and the number of segments. Note that the Single Acquisition mode is just a special case of the Sequence Acquisition mode with the number of segments set to 1.

Sequence acquisition enables successive events, which can occur within a very short time, to be captured and stored without loss. A crucial feature of Sequence Acquisition mode is that it has a very fast trigger rearm time. A fast trigger rearm helps produce very low “dead time” (less than 800 ns for the highest available sampling rates in most units, however 350 ns for the U1071A-FAMILY internal memory and 1.8  $\mu$ s for its external memory, 1.8  $\mu$ s for the U1084A) between the segments of a sequence acquisition. The “dead time” is the period after the end of an event when the card cannot digitize data for a new trigger event. To complement this mode of operation the digitizer can also measure and store the arrival time of each trigger using the information from the on board Trigger Time Interpolator (TTI). Readout of the individual trigger time stamps makes it possible to determine the time from one trigger to any other trigger in the sequential acquisition. The TTI resolution sets the resolution of the trigger time stamps (see section 3.3.5 **Timing** and the table above).

### 3.3.4. U1071A-FAMILY and U1084A Simultaneous multibuffer Acquisition and Readout (SAR)

For this module the internal memory has a dual-port structure which can be exploited to permit simultaneous data acquisition and read out. When the special SAR option is present the internal memory can be turned into a circular buffer of a chosen number of banks, between 2 and 1000 (U1084A supports 2 banks). Data can be read out of one bank while data is acquired into any available free banks. This mechanism, together with sequence acquisition, helps achieve a high maximum continuous event rate in spite of interrupts due to the computer operating system. The maximum continuous event rate is the maximum value of the trigger frequency that can be accepted without the loss of any event. It will work for both 1 and 2 converter/channel modes. It does not work if the ‘Start on Trigger’ mode of acquisition is selected nor when the AS bus is present. The number of segments ( $N_s$ ) available per bank ( $N_b$ ) must respect the constraint that the total  $N_b * N_s < 1000$ .

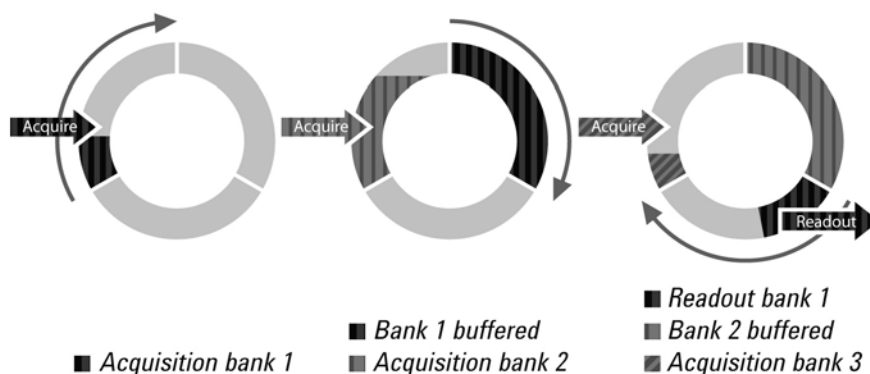

### 3.3.5. Timing

A crystal-controlled timebase is used to clock the ADC system of the digitizers. The timebase accuracy is guaranteed as shown in the table at the beginning of this section. The digitizers also include a built-in Trigger Time Interpolator (TTI) that measures the time from the trigger point to the first sample point. This information is essential for determining the precise relation between the trigger or other event of interest and the digitized samples of the signal. The approximate TTI resolution is also given in the table at the beginning of this section.

### 3.3.6. Timebase Range

The timebase range defines the time period over which data is being acquired. For example, the DC110 has a standard acquisition memory of 128 Kpoints and maximum sampling rate of 1 GS/s. Therefore, at the maximum sampling rate, the digitizer can record a signal over a timebase range of up to 130  $\mu$ s (approx. 130,000 points \* 1 ns/point). The timebase range can be adjusted by varying the amount of acquisition memory or the sampling rate of the digitizer.

### 3.3.7. Combining channels

The DC135/DC135HZ/DC140/DC140HZ/DC241/DC241A/DC271/DC271A/DC271AR/DP235/DP240/U1071A-FAMILY, U1084A digitizers offer the possibility of combining the converters (and their memories) from two or four channels to analyze a single input channel. With this feature the maximum sampling rate and the maximum amount of acquisition memory can be doubled or quadrupled if all of the input channels are not of immediate interest.

### 3.3.8. Sparkle Code Rate

Acqiris digitizers contain analog-to-digital conversion (ADC) systems that sample waveforms at high sampling rates. A data value from any ADC will often differ from the ideal code that would best represent the input signal. This happens for many reasons including noise, non-linearity, and harmonic distortion. Furthermore, all ADC circuits also exhibit an effect called “sparkle code”, which is due to a (rare) error in the binary coding of the output value. A sparkle code error is generated when the ADC erroneously sets a 1 instead of a 0 (or a 0 instead of a 1) in the binary output code. The frequency of such errors may be specified as a probability of a deviation above a defined threshold per converted data value. E.g. a sparkle code rate (sometimes also called BER, bit error rate) of  $10^{-9}$  would indicate that 1 data value out of 1 billion is a sparkle code, on average. Modern digitizing systems offer both large memory and high transfer rates to the host computer. This allows large quantities of data to be easily examined and the sparkle codes become obvious. Depending on ADC design details, the frequency of sparkle code errors can be diminished.

Most of the time, a sparkle code is quite easily recognizable as a rare, but large, deviation of the output from the expected value. The error is often in a single bit so the deviation is  $2^m$ . The signal therefore shows an unexpected sharp “spike” in an otherwise smooth waveform. In some 8-bit ADCs, the effect is most likely to occur around specific output levels such as 0, 64, and -64, and the deviation is typically  $\pm 64$  or  $\pm 32$ . In applications that are particularly sensitive to sparkle code it is recommended to avoid such levels, and adjust the digitizer offset such that the baseline (if any) does not fall on the specific code values shown above.

For example, if a ~500 mV peak-peak input signal is usually right at 0 V and occasionally at 500 mV, it makes sense to program the vertical gain at 1 V full scale and the offset at -200 mV which puts the baseline at -51 and the peak at +77; both values here are away from the danger points. It would not be recommended to put the offset at -250 mV with a 1 V full scale, as this would set the baseline around -64, and peak at +64 where we are more likely to see sparkle codes, and erroneous data.

### 3.3.9. U1084A Zero-Suppress Mode

The U1084A model supports a Zero-Suppress mode which allows null-data or data below a desired threshold to be excluded from the acquisition. This allows only the relevant portions of a signal to be acquired, thus optimizing the use of the data memory.

In order to implement this function the user may configure a set of thresholds (up to 128) which will be applied in sequence. Each threshold is specified by a value in Volts and the index of the sample in the segment at which the system should switch to the next threshold.

In the example below, the threshold line is shown in blue, and the acquired data in red. The threshold has been set-up as follows:

- [0] Threshold = 0.25 (V), nextThreshSample = 10240
- [1] Threshold = 0 (V), nextThreshSample = 20480
- [2] Threshold = -0.25 (V), nextThreshSample = 30720
- [3] Threshold = 0 (V)

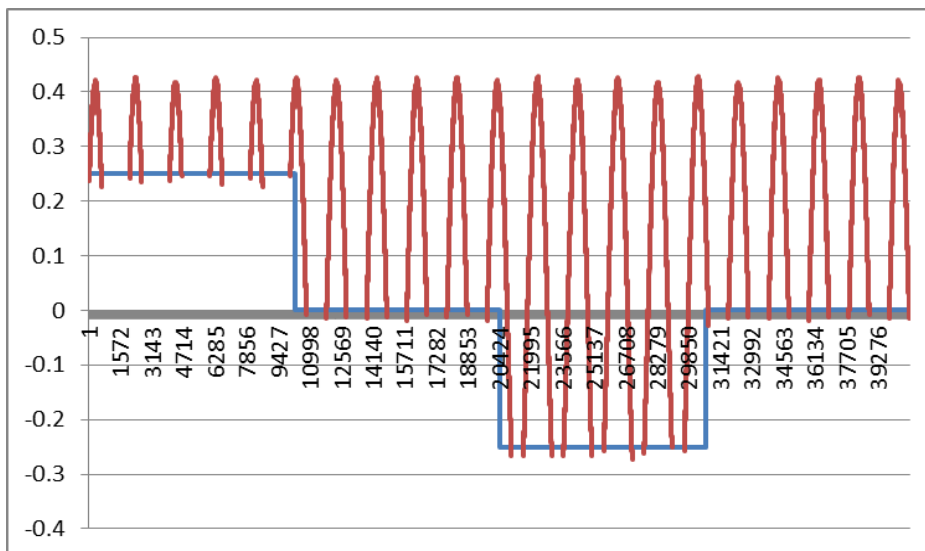

It should be noted that setting the threshold to the minimum value will cause the digitizer to save all of the acquired data, and conversely setting the value to maximum will cause no data to be saved. In this way a 'pre-defined gate' type acquisition may be achieved as in the example below:

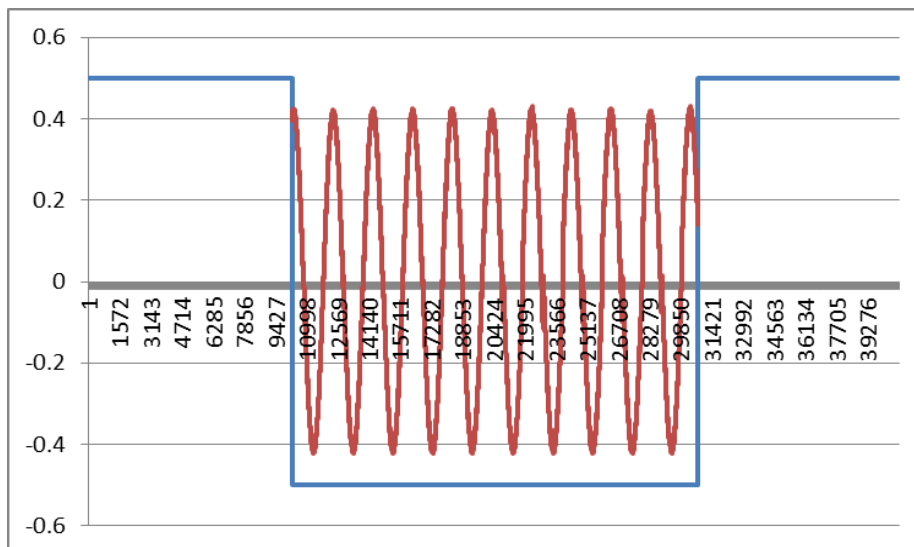

The following are the required parameters to configure the operation of the zero-suppress mode:

**Acquisition Parameters:**

**NbrSegments** – The number of waveform segments to acquire.

**NbrSamples** – Nominal length of each segment in samples, counting all samples above or below the zero-suppression thresholds. This value must be a multiple of 2048 in dual channel mode (no channel combination), or 4096 in single channel mode (channels 1 & 2 combined). The maximum value depends on NbrSegments.

**InvertData** – Allows inversion of the acquired data.

**PreSamples** – Used to guarantee a number of samples before the first one which satisfies the threshold condition. This value must be a multiple of 16 in dual-channel mode (no channel combination), or 32 in single channel mode (channels 1 & 2 combined).

**PostSamples** – Used to guarantee a number of samples after the last one satisfying the threshold condition. This value must be a multiple of 16 in dual-channel mode (no channel combination), or 32 in single channel mode (channels 1 & 2 combined).

**MaxSamplesPerSegment** – Defines the maximum number of samples to be stored per segment in Zero-Suppression (gating) mode, per channel. This parameter can be used to limit the readout time.

### Threshold Configuration Parameters:

Threshold parameters are defined by an array of up to 128 items, containing:

**threshold** – Threshold value in Volts.

**nextThreshSample** – The index of the sample in the segment at which the Zero-Suppression system should switch to the next threshold value.

Please refer to the Programmers Reference (U1092-90002) for further detail on configuration of this function.

## 3.4. Trigger

Normally the trigger settings applied to the digitizer are used to determine the time at which the device will stop acquiring data. Some models are also capable of a ‘Start on Trigger’ mode of acquisition (see the Programmer’s Guide for further details). The various trigger settings are outlined below.

### 3.4.1. Trigger Source

The trigger source can be a signal applied to either an Input Channel (internal triggering) or the External Trigger Input. For the DC135/DC135HZ/DC140/DC140HZ/DC211/DC211A/DC241/DC241A/DC271/DC271A/DC271AR modules, a standardized trigger in signal can also be routed via the PXI Bus Star Trigger line.

Most digitizers provide a separate front panel input BNC connector that can be used as an External Trigger Input. The External Input provides a fully functional trigger circuit with selectable level and slope as for the Internal Triggering source; however it does not include coupling choices nor HF, Window, and Spike Stretcher triggers. The external trigger termination (1 M $\Omega$  or 50  $\Omega$ ) is also selectable on many modules. In modules with this feature, the circuit also provides an overload protection that will automatically switch the coupling from 50  $\Omega$  to 1 M $\Omega$  if the signal is greater than  $\pm 5$  V DC.

The DC271-FAMILY digitizers have a fixed 50  $\Omega$  termination impedance. They also allow the same BW limiter selections as can be found for the channels. The DC271-FAMILY digitizers’ external trigger circuit has diode protection against overload.

The U1071A-FAMILY and U1084A also gives the choice of 50  $\Omega$  or 1 M $\Omega$  termination impedance for the MCX external input and has diode protection against overload. However, there are no BW limiters and only DC trigger coupling is available.

In all 50  $\Omega$  cases a  $\pm 5$  V limit on trigger signals should be respected, although somewhat higher voltages for short time periods will not damage the unit. For 1 M $\Omega$  input signals up to  $\pm 100$  V (DC + peak AC < 10 KHz) are allowed.

### 3.4.2. Trigger Coupling

Trigger coupling is used to select the coupling mode applied to the input of the trigger circuitry. Modes available include AC LF Reject and DC. The AC LF Reject mode couples signals capacitively and removes the input signal’s DC component and signals below 50 kHz (50 Hz for DC271-FAMILY digitizers). DC mode allows all signal components to be passed through to the trigger circuit. The DC271-FAMILY digitizers have an HF Reject mode that removes signal components above 50 kHz. The U1084A offers DC as well as AC and HF reject with a 50 kHz cut-off.

### 3.4.3. Trigger Level

The trigger level specifies the voltage at which the selected trigger source will produce a valid trigger. The trigger level is defined as a set voltage. Using the internal trigger, the level is set with respect to the midpoint voltage ( $V_m = \text{Offset voltage}$ ) of the digitizer’s vertical scale. Internal trigger level settings (expressed in %) must be within  $V_m \pm 0.6$  FS (0.5 FS for DC271-FAMILY digitizers), where FS is the channel Full Scale. All trigger circuits have sensitivity levels that must be exceeded in order for reliable triggering to occur.

For most digitizers, the AC coupled mode is implemented with an auto-level trigger. Only the DC271-FAMILY and U1084A digitizers allow trigger levels to be selected in connection with the AC coupling choices.

The DC271-FAMILY digitizers allow the user to choose the external trigger Full Scale from the set of values 0.5, 1.0, 2.0 or 5.0 V. The external trigger level can then be set to values in the range  $\pm 0.5$  FS. The U1071A-FAMILY has a single external Trigger Full Scale of 10 V. The U1084A has a range of  $\pm 5$  V. All other digitizers have an external trigger range of  $\pm 3$  V.

The DC271-FAMILY and U1084A digitizers will trigger on signals with a peak-peak amplitude  $> 15\%$  FS from DC to their bandwidth limit.

#### 3.4.4. Edge Trigger Slope

The trigger slope defines which one of the two possible transitions will be used to initiate the trigger when it passes through the specified trigger level. Positive slope indicates that the signal is transitioning from a lower voltage to a higher voltage. Negative slope indicates the signal is transitioning from a higher voltage to a lower voltage.

#### 3.4.5. Window Trigger

The DC271-FAMILY digitizers and the 2 channels of the U1071A-FAMILY implement a Window trigger. Two trigger level thresholds are used to define the desired range. The trigger can then be chosen to occur either when the signal exits or enters the window range. This mode can be thought of as the appropriate OR of two edge triggers of opposite slope.

#### 3.4.6. HF Trigger

The DC271-FAMILY digitizers and the 2 channels of the U1071A-FAMILY and U1084A implement an HF trigger that allows triggers to be reliably accepted at rates above  $\sim 1$  GHz. In this mode, triggers occur on every fourth positive edge. The window trigger mode is not available.

#### 3.4.7. Spike Stretcher

The trigger circuit of the 2 channels of the U1071A-FAMILY and U1084A also has a Spike Stretcher mode which ensures that even very short pulses are capable of generating triggers. This mode is useful if the time interval during which the trigger signal satisfies the threshold condition is less than 0.5 ns and the trigger frequency is less than 10 MHz. The trigger slope is positive in this mode.

#### 3.4.8. U1071A-FAMILY and U1084A Multi-source Trigger

This digitizer permits triggers that require a pattern condition including one of the trigger channels and the external trigger. The trigger condition defined above, on each of the inputs, defines the TRUE/FALSE state of each input. These states can be logically combined with AND, OR, NAND, or NOR to define the overall trigger condition. Potential triggers can then occur on the FALSE to TRUE transitions of the combined signal.

There is a small ( $\sim$ ns) delay between the times at which two simultaneous inputs arrive at the logical element that defines the overall trigger condition. If necessary, this must be corrected for by cable delay on the external input; the delay will depend on the overall configuration and therefore must be determined by the user.

#### 3.4.9. Pre- and Post-Trigger Delay

To increase trigger flexibility a pre- or post-trigger delay can be applied to the trigger position.

The amount of pre-trigger delay can be adjusted between 0 and 100% of the acquisition time window (i.e. sampling interval x number of samples), whereas the post-trigger delay can be adjusted between 0 and 200 million samples. The U1071A-FAMILY allows a post trigger delay of up to  $2^{34} - 1$  samples.

Pre- or post-trigger delays are just different aspects of the same trigger positioning parameter:

- The condition of 100% pre-trigger indicates that all data points are acquired prior to the trigger, i.e. the trigger point is at the **end** of the acquired waveform.
- The condition of 0% pre-trigger (which is identical to a post-trigger of 0) indicates that all data points are acquired immediately after the trigger, i.e. the trigger point is at the **beginning** of the acquired waveform.



- The condition of a non-zero post-trigger delay indicates that the data points are acquired after the trigger occurs, at a time that corresponds to the post-trigger delay, i.e. the trigger point is **before** the acquired waveform.

The digitizer hardware accepts pre- and post-trigger adjustments in increments of 16 samples. By definition post-trigger settings are a positive number and pre-trigger settings are a negative number.

Thus it is only natural that the software drivers treat pre- and post-trigger delays as a single parameter in seconds that can vary between  $-nbrSamples * samplingInterval$  (100% pre-trigger) and  $+maxPostTrigSamples * samplingInterval$  (max post-trigger). Since the Acqiris software drivers provide very accurate trigger position information upon waveform readout, the accepted resolution of the user-requested pre-/post-trigger delay is much better than 16 samples. For more details, refer to the Programmer's Guide.

### 3.4.10. Trigger Status

The front panel includes a tri-color LED indicator to show the status of the trigger. When the LED is green it indicates the trigger is armed and waiting for a valid trigger to occur. Red indicates that the trigger has occurred, the acquisition is complete and the data is waiting to be readout. For the U1071A-FAMILY a yellow LED is an indication of a timeout when the PC tried to communicate with the module. The user can override the default functions and program the LED color in an application-specific manner.

## 3.5. External Clock and Reference

For applications where the user wants to replace the internal clock of the digitizer and drive the ADC with an external source, either an External Clock or an External Reference signal can be used. The Clock or Reference signals can be entered into the digitizer either by the dedicated MMCX (DC271-FAMILY), MCX (U1071A-FAMILY and U1084A), or BNC (DC240) connector or via the shared External Input connector on the front panel (all other models). In addition, for the DC135/DC135HZ/DC140/DC140HZ/DC211/DC211A/DC241/DC241A/DC271/DC271A/DC271AR models, the PXI Bus 10 MHz system clock signal (PXI\_CLK10) can be used as the reference.

With External Clock two operating modes are possible; Continuous for the case in which the clock signals are always present and Start/Stop for the situation where the user needs complete control of the sampling process. The Start/Stop mode is not available for the U1071A-FAMILY. When using a Continuous External Clock, the user must ensure that the input signal has a frequency between 20 MHz and 2 GHz (U1071A-FAMILY and DC271-FAMILY) or between 10 MHz and 500 MHz (all other models). For the Start/Stop mode the input signal frequency must be less than 1 GHz (DC271-FAMILY) or 500 MHz (all other models). In all cases it must have a minimum peak to peak amplitude into 50  $\Omega$  at the front of the digitizer of at least

- 0.5 V for DC135/DC135HZ/DC140/DC140HZ/DC211A/DC241A/DC271A/DC271AR/U1071A-FAMILY
- 1 V all other DC271-FAMILY and U1084A
- 2 V for other models.

The U1071A-FAMILY has a fixed threshold and uses AC coupling. Otherwise, the transitions of the clock are defined with the aid of a threshold that is user selectable in the range [-2.0 V, 2.0 V] ([-3.0 V, 3.0 V] for the DC240). The signals should not exceed  $\pm 5$  V amplitude ( $\pm 1$  V a.c. for the U1071A-Family). For a detailed discussion on the programmed use of the external clock, refer to the Programmer's Guide.

For applications that require greater timing precision and long-term stability than is obtainable from the internal clock, a 10 MHz Reference signal can be used. The External Reference is nominally at 10 MHz. However, frequencies in the range [9.0 MHz, 10.2 MHz] will be accepted for all models other than the U1071A-FAMILY and U1084A. If you do this you may need to correct for the difference in your application since the digitizer and the driver have no way to know about such deviations. The amplitude and threshold conditions, for an External Reference, are the same as for the External Clock. If synchronization between several digitizers is required, the reference signal should be applied to all of them.

## 3.6. Internal Calibration

The software drivers supplied include calibration functions for the timing, gain and offset settings, which can be executed upon user request. The digitizers are never calibrated in an "automatic" way, i.e. as a side effect of another operation. This ensures programmers have full control of all calibrations performed through software in order to maintain proper event synchronization within automated test applications.

The model DC and DP series digitizers include a high precision voltage source and a 16-bit DAC, used to determine the input voltage and offset calibration.

For accurate time and voltage measurements it is recommended to perform a calibration once the module has attained a stable operating temperature (usually reached with a few minutes of digitizer operation after power on). Further calibration should not be necessary unless temperature variations occur.

A full internal calibration of a digitizer can be very time consuming (> 100 s/digitizer), in particular for the DC2x1A models. Therefore, several other options are available. They are documented in the **Programmer's Reference Manual**. A program can always be started with the digitizer in an uncalibrated state and data taken can be used for many kinds of testing. However, as soon as good data respecting the specifications of the instrument is required a calibration of at least the current acquisition state is needed. The full internal calibration has the advantage that it generates the calibration constants needed for any possible configuration of the instrument; its disadvantage is the time taken. If a more selective calibration is done it will allow the generation of good data in the current acquisition state. This calibration will remain useable whenever that acquisition state is used again for as long as the temperature of the instrument does not change significantly. A fast calibration of a channel in a configuration can be done in around a second. Many applications can save time by only performing calibration for the configurations that will actually be used. Calibration can usually be performed with signals present at the channel, external, and clock inputs. However, if the calibration is found to be unreliable, as shown by a calibration failure status, it may be necessary to remove such signals.

### 3.7. Factory Calibration

Whilst the Internal Calibration function will provide a good degree of confidence that your instrument is operating within its specifications on a day-to-day basis, Agilent recommends that each instrument undergoes a Factory Calibration at least annually to ensure that it remains within the specified performances.

Factory Calibration is the process of measuring the actual performance of an instrument-under-test using lab instruments that in turn have significantly better performance than the instrument-under-test. Lab instrument performance must be traceable to the International System (SI) Units via a national metrology institute (NIST, NPL, NRC, PTB, CENAM, INMETRO, BIPM, etc.)

The measured performance is then compared to published data sheet specifications. Agilent Technologies tests the performance corresponding to all data sheet specifications, for all installed options, every time. If we observe your instrument to be out-of-specification, we always adjust it and re-test before we return it to you.

For more information, or to return your instrument to Agilent for calibration please see [www.agilent.com/find/calibration](http://www.agilent.com/find/calibration)

### 3.8. AS bus

The DC Series digitizers may be used in applications that require many data acquisition channels. In such cases it is possible to use more than one digitizer in a standard CompactPCI/PXI crate. Each DC Series digitizer, except the DC135, DC140 and U1084A models, includes AS bus, a proprietary high bandwidth auto-synchronous bus system that allows multiple digitizers to work together synchronously.

The AS bus distributes both the clock and trigger signals along a plug-in front panel bus, between all the digitizers that participate in the system. It allows any digitizer to act as the trigger source and any other digitizer to act as the clock source (acquisition master), enabling all the digitizers to be clocked at the same time. Synchronizing the clock signals between the devices improves the accuracy of cross-channel measurements and is essential for accurate time correlation between signals on different channels.

The AS bus is intended to connect modules of the *same type*, i.e. of the same model number, although some exceptions to this rule might be possible. If modules with the same model number, but different memory length options, are connected only the shortest memory length can be used.

The AS bus connector is located on the front panel of each cPCI module. Bridges are used to connect adjacent modules for synchronization, which is then activated through software by defining a master module and the trigger source. Up to 7 modules may be synchronized with the AS bus. More detailed information and the commands required to setup the AS bus clock and trigger distribution are included in the **Programmer's Guide** and **Programmer's Reference Manual**.

The U1071A-FAMILY uses the AS bus 2 system with a connector on the top of each card to achieve the same functionality. It works for up to 3 modules.

### 3.8. Special Front Panel Input and Output (U1071A, DC271-FAMILIES and U1084A)

Connector	Function
CLK IN	50 Ω External Reference or External Clock Input
I/O A	User configurable (see below)
TR OUT	Signal occurs after an accepted TRIGGER.
I/O B	User configurable (see below)
I/O C	User configurable (see below) (U1084A only)

Most digitizers use MMCX connectors for these functions. however the U1071 Family uses the MCX type. If the AS bus system is being used the MMCX connectors of the master module are active.

#### 3.8.1. Multi-Purpose Input and Outputs (I/O A, B, C)

The I/O A, I/O B or I/O C may be used as any of the functions shown in the table below:

Function	Direction	Description
Enable Trigger	Input	
10 MHz Ref Clock	Output	To ensure good rise time characteristics the output impedance is 50 Ω This signal can be used as an input to 1 (or 2 using a T split) CLK IN connectors. Note: This signal is the internal 10 MHz and is not available if the External Reference Clock is in use.
Acquisition skipping to next segment	Output	
Acquisition is active	Output	Indicates that the acquisition is currently running.
Trigger is armed	Output	Indicates that the trigger is armed and waiting for a valid trigger event.

To ensure proper operation of the segment recording of hardware markers, the logical state of MCX I/O A, MCX I/O B, and MCX I/O C inputs, the input must be stable for a time interval starting 30 ns before the trigger and continuing until 30 ns after it. This implies that the HF Reject trigger coupling should not be used. If the individual inputs are not in the disable state the corresponding bits will be useless.

The I/O A, I/O B, and I/O C signals are 3.3 V CMOS compatible, with the following levels:

Direction	Low Level	High Level
Input	<0.8 V	>2.0 to 3.45 V
Output	0 to 0.8 V	1.7 to 3.3 V

An unconnected input will be pulled high. The high level output will typically give 0.8 V into 50 Ω.

#### 3.8.2. TRIGOUT

The TRIGOUT Signal occurs after an accepted TRIGGER. It can be chosen to be either synchronous to the Trigger IN or synchronous to the acquisition Clock and, in this case, can be used to trigger events synchronously to the acquisition clock.

### 3.9. External Trigger Output (U1071A & DC271-FAMILIES and U1084A)

When the digitizer is ready to be triggered and a valid trigger signal occurs, a trigger output is generated for external use. It is always available on the Front Panel Trigger Out MCX or MMCX connector. The pulse ends when the data acquisition for the trigger in question is complete.



**NOTE:** The External Trigger Output functionality is implemented in the hardware. No Trigger Out signal occurs for software-generated triggers such as those of the AUTO mode of AcqirisLive or through the use of the function *AcqrsD1\_forceTrigger*. However, *AcqrsD1\_forceTriggerEx* does generate the signal.

Trigger Output Block diagram:

The output swing is 1.6 V ( $\pm 0.8$  V) when unloaded and 0.8 V when terminated on 50  $\Omega$ . The rise and fall times are 2.5 ns typical. The offset can be adjusted, by software control in the range  $[-2.5$  V,  $+2.5$  V] unloaded, or  $[-1.25$  V,  $+1.25$  V] into 50  $\Omega$ . The maximum output current capability is  $\pm 15$  mA. As the output is retro-terminated, it is possible to drive a 50  $\Omega$  line unterminated (HiZ) without loss of performance.

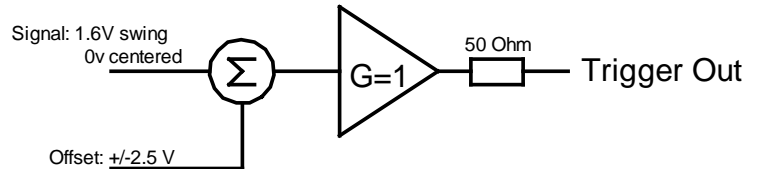

For a TTL compatible signal, set the offset to 1.0 V and the swing at destination will be  $+0.2$  to  $+1.8$  V.

For an ECL compatible signal, terminated on 50  $\Omega$  to  $-1.2$  V, set the offset to  $-1.2$  V and the output will be in the range  $[-0.8$  V,  $-1.6$  V]).

Alternatively, to reduce the current drawn from the digitizer, the terminations shown here can be used:

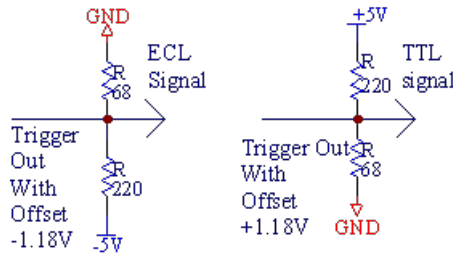

For the DC135/DC135HZ/DC140/DC140HZ/DC211/DC211A/DC241/DC241A/DC271/DC271A/DC271AR modules, a standardized trigger out signal can also be routed to the PXI Bus Star Trigger line.

For the U1071A-FAMILY the offset control range is reduced slightly. It is  $[-2.3$  V,  $+2.3$  V] unloaded, or  $[-1.15$  V,  $+1.15$  V] into 50  $\Omega$ .

### 3.10. Frequency Counter mode

The DC140 and DC135 digitizers offer an optional Frequency Counter (FC) mode. This option allows the measurement of the average frequency or period of a signal for frequencies up to 400 MHz over a user-selectable aperture between 1 ms and 1000 s. The accuracy is limited by that of the timebase,  $< 2$  ppm; the short term stability is of  $\sim 0.1$  ppm. The accuracy can be improved if an appropriate external reference clock is used. Frequencies in excess of 100 MHz will be measured using the HF divide by four feature of the trigger circuit.

A digitizer with the FC option can also totalize the number of triggers during a chosen time interval or a user-provided gate signal. This can be done for trigger frequencies under 125 MHz and for total counts up to  $2^{48}$ . The time interval is measured using the same clock as is being used to drive the digitizer. The user gate signal has to be made available on one of the Control I/O inputs.

### 3.11. Electrical, Environmental and Physical Specifications

#### 3.11.1. Electrical

Model	PCI Rev	DMA Transfer Rate (MB/s)	Max. Power Consumption (W)		Current Requirements (A) (with Memory option)			
			Standard	WITH MEMORY OPTION	+12 V	+5 V	+3.3 V	-12 V
<b>DP105/106</b>	2.1	~100	14.4	16.1	0.55	1.3(1.6)	n/a	n/a
<b>DP110</b>	2.1	~100	15.7	16.8	0.46	1.7(1.9)	n/a	0.02
<b>DP111</b>	2.1	~100	18.0	21.3	0.75	1.4 (2.0)	n/a	0.03
<b>DP210</b>	2.1	~100	21.8	24.0	0.6	2.4 (2.8)	n/a	0.05
<b>DP211/212</b>	2.1	~100	18.0	21.3	0.75	1.4 (2.0)	n/a	0.05
<b>DP214/235/240</b>	2.2	~100	24.4	27.3	0.8	1.2	1.8 (2.6)	0.05
<b>DP1400 U1071Axxx U1091AD28</b>	2.3	~200	16.3	20.3	0.09	1.4	1.9(3.0)	0.04
<b>U1084A</b>		~520	40	50	2.5	n/a	4.0	n/s
<b>DC110</b>	2.1	~100	16.7	18.6	0.7	1.1	0.4 (0.9)	n/a
<b>DC135 DC135HZ</b>	2.2	~20	13.1	14.6	0.46	0.46	1.1 (1.5)	0.04
<b>DC140 DC140HZ</b>	2.2	~20	14.2	17.1	0.46	0.46	1.4 (2.2)	0.04
<b>DC211/211A</b>	2.2	~100	45.7	52.5	1.5	2.6	3.0 (4.9)	0.05
<b>DC240</b>	2.1	~100	40.9	46.4	1.3	3	2 (3.5)	n/a
<b>DC241 DC241A</b>	2.2	~100	45.7	52.5	1.5	2.6	3.0 (4.9)	0.05
<b>DC265</b>	2.1	~100	37.1	43.0	1.2	2.5	1.9 (3.5)	0.05
<b>DC270</b>	2.1	~100	40.4	51.7	1.2	2.5	2.8 (5.9)	0.05
<b>DC271 DC271A DC271AR</b>	2.2	~100	45.7	52.5	1.5	2.6	3.0 (4.9)	0.05

The Maximum Power Consumption has been increased by 10% over the value calculated with the currents shown to take into account higher allowed values of the crate or PCI voltages.

The U1071A-FAMILY can use the PCI Bus at frequencies up to 66 MHz. U1084A. All other 8-bit Acqiris digitizers use the PCI Bus at 33 MHz only. All modules are compatible for either V I/O = 3.3 V or 5 V.

### 3.11.2. Environmental and Physical

The U1071A-FAMILY and U1084A modules have a Declaration of Conformity according to EN ISO/IEC 17050-1:2004 and the EMC Directive 2004/108/EC and carry the **CE** Marks of Compliance. This Declaration can be viewed at <http://www.agilent-pra.com>. All other modules have a Declaration of Conformity according to EN ISO/IEC 17050-1:2004 and the EMC Directive 2004/108/EC and carry the **CE** Marks of Compliance.

The front panels of the CompactPCI modules are in compliance with the IEEE 1101.10 standard.

#### Operating Temperature

0° to 40°C – for the DC271-FAMILY modules

5° to 40°C – for U1084A

0° to 50°C – all other modules

For the DCxxx compactPCI modules the above values are for the ambient temperature of the room (or equivalent) where the CompactPCI crate is located. For DPxxx PCI modules, located in a PC (or equivalent), it is the cooling air temperature inside the box that is of interest. This can be significantly higher than the ambient air temperature of the room. In both cases the temperature as measured on the board may well be significantly higher. On-board temperatures above 60°C should be avoided. If a PCI module indicates a temperature > 60°C ventilation should be added or improved if possible.

#### Relative Humidity

Type tested at 95%, +40°C (non-condensing)

#### Dimensions

All DP modules conform to the PCI standard. The DP214/DP235/DP240 and DP211/DP212/DP111 modules are 107 mm × 210 mm and require a long card slot. If used with the XP103 fan they can be adjusted to conform to the full 342 mm length. The U1071A-FAMILY measures 107 mm × 170 mm without its fan. If used with the XP104 fan it can be adjusted to conform to the full long card length of 342 mm; when the XP105 fan is used the overall length is 235 mm. All other cards require a short card slot (107 mm × 175 mm). An XP100 fan will add 45 mm to the length of any card.

The DC110, DC135, DC135HZ, DC140, and DC140HZ conform to the 3U CompactPCI standard (100 mm × 160 mm × 20 mm). All other DC modules conform to the 6U CompactPCI standard (233 mm × 160 mm × 20 mm).

The U1084A conforms to the PCIe full-length standard. Note that the rear fan unit uses 2 slots width, but may be turned by 180° to accommodate differing PC / chassis dimensions, or to allow two U1084A units to be operated side-by-side. (see Appendix on Fan Assemblies).

#### EMC Immunity & Emissions

Complies with European EMC Directive

- IEC/EN 61326-1
- CISPR Pub 11 Group 1, class A
- AS/NZS CISPR 11
- ICES/NMB-001 - This ISM device complies with Canadian ICES-001. Cet appareil ISM est conforme à la norme NMB-001 du Canada.

#### Required Airflow

> 2 m/s in situ for units dissipating > 30 W

In order to guarantee the above performance and specifications, PCI digitizer cards must be installed in a PCI metal frame with adequate cooling. The card's front panel must be screwed to lock the digitizer into place and ensure proper grounding of the frame. The frame must not be used without closing all vacant front panel slots to guarantee EMC shielding and cooling. Similarly cPCI modules must be screwed to lock them into place and insure proper grounding. The crate must not be used without closing all vacant front panel slots to guarantee EMC shielding and cooling.

The U1084A Digitizers are supplied with a fan unit. This fan unit is required for operation, and should not be removed. This fan assembly takes up 2 PC slots at the rear. It has been designed to be mounted in either a left or right orientation to allow adaptation to different PC or chassis hardware, or also to allow two U1084A modules to be positioned side-by-side. See Fan Assembly information in the appendix.

## 4. Soft Front Panel (SFP) Applications

The Agilent SFP Applications (previously called AcqirisLive) are intended to verify the functionality of the card and to serve as an easy to use and convenient program for capturing, displaying, and archiving captured data.

This program uses the AgMD1 and other associated drivers to control any supported digitizers. It is installed at the same time as those drivers.

### 4.1. SFP Versions

There are currently two versions of the SFP application.

The SFP 1.x version is gradually being phased out by the introduction of the SFP version 5. However at this point in time the SFP 5 application does not fully support all products, modes of operation or features that are supported by the SFP 1.x, and so the user must decide which SFP to use depending on their application.

#### 4.1.1. SFP 5.x

This newer version of the SFP application supports all products which are covered by the MD1 driver. New features, and replication of features which currently exist in the older SFP 1.x will be introduced progressively into the 5.x version.

This version supports:

- All Agilent U10xx (8, 10 & 12-bit Digitizers).
- All Agilent Mxxxx series Digitizers. (Except M9202A in DDC mode)
- DGS, DCT, SAR/SSR, Peak TDC modes of operation.

#### 4.1.2. SFP 1.x

This application which was previously known as 'AcqirisLive' contains some features which have not yet been implemented in the SFP 5 application. Users who prefer this application or wish to use one of the features below may continue to do so.

This version is required currently if you wish to use any of the following instruments, or features:

- Using M9202A in DDC mode.
- U1082A, AP100 or AP200 Averagers.
- Using multiple modules at the same time.

### 4.2. SFP Documentation

Information on the operation of both of the above SFP versions may be found in the 'AgMD1 Digitizers – User Guide & Soft Front Panel Help'. This is an HTML Help system (.chm) which may be found on the CD supplied with your product, or from the windows 'Start Menu' after you have installed your product software. Look under – **Start > All Programs > Agilent > MD1 > MD1 Help**

## 5. Appendix A: U1093A (U1056A) AS bus for CompactPCI/PXI Digitizers

### Specification and User Instructions for AS1, AS2, AS3, AS4

#### SPECIFICATIONS :

ASBus Bridges allow the connection and synchronization of up to 7 DC series digitizers (up to 28 channels). Acqiris recommends having the master digitizer in the center of the group in order to obtain the best performance possible.  
 Clock synchronization accuracy :  $\pm 100\text{ps}$ .

Install/Remove the ASBus Bridges as follows :

- Make sure that the screws securing each of the modules to the crate are not completely tightened.
- Before inserting the ASBus bridge, manually adjust any difference in the module separation, such that the distance between the center of the connectors corresponds to that of the ASBus bridge.
- Carefully insert/remove the ASBus bridges between each pair of modules. Force should not be required.
- Tighten the screws of each of the modules.
- If desired, add an XB104 Retainer on each handle to secure the ASBus bridge against vibration. It clicks into place when fully inserted. It can be easily removed by pulling on the lower half of the Retainer while sliding it off.

#### User Instructions for 2 digitizers :

ASBus dual termination bridge XB103

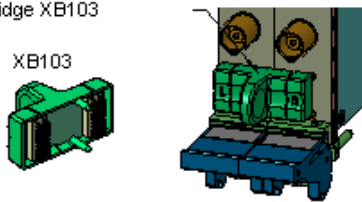

#### User Instructions for 3 digitizers :

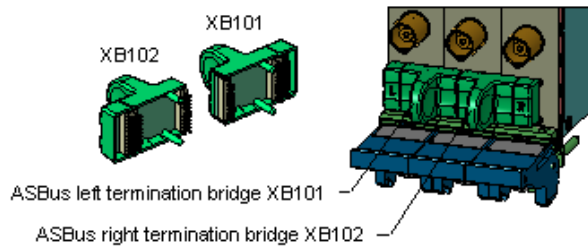

#### User Instructions for 4 to 7 digitizers :

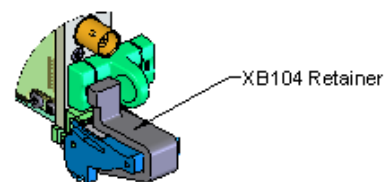
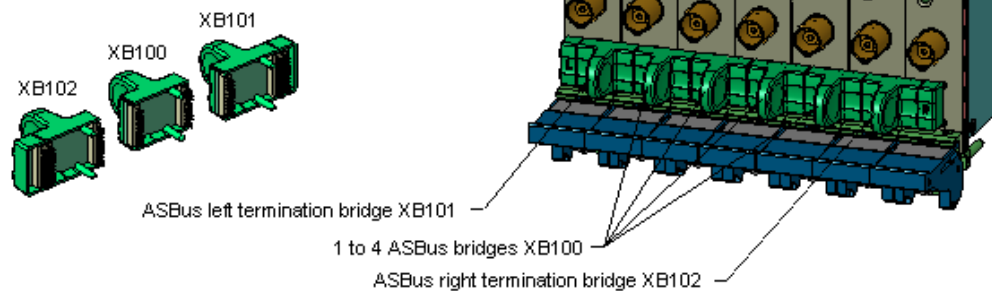



## 6. Appendix B: U1093A-AS6 (U1056A-A06) AS bus 2 for PCI Digitizers

### SPECIFICATIONS :

ASBus<sup>2</sup> Bridges allow the connection and synchronization of up to 3 DP1400 PCI digitizers

Clock synchronization accuracy:  $\pm 100$ ps.

### USER INSTRUCTIONS :

Bridges can be installed/removed on units when they are powered. An application using the digitizers must be restarted after such changes are made.

Install/Remove the XB300 ASBus<sup>2</sup> Bridges as follows :

- Make sure that the front panel screws securing each of the modules to the crate are not completely tightened.
- Carefully insert/remove the XB300 bridges between each pair of modules. Force should not be required while inserting the XB300, manually adjust any difference in the module separation, such that the distance between the center of the connectors corresponds to that of the XB300.
- Tighten the screws of each of the modules.

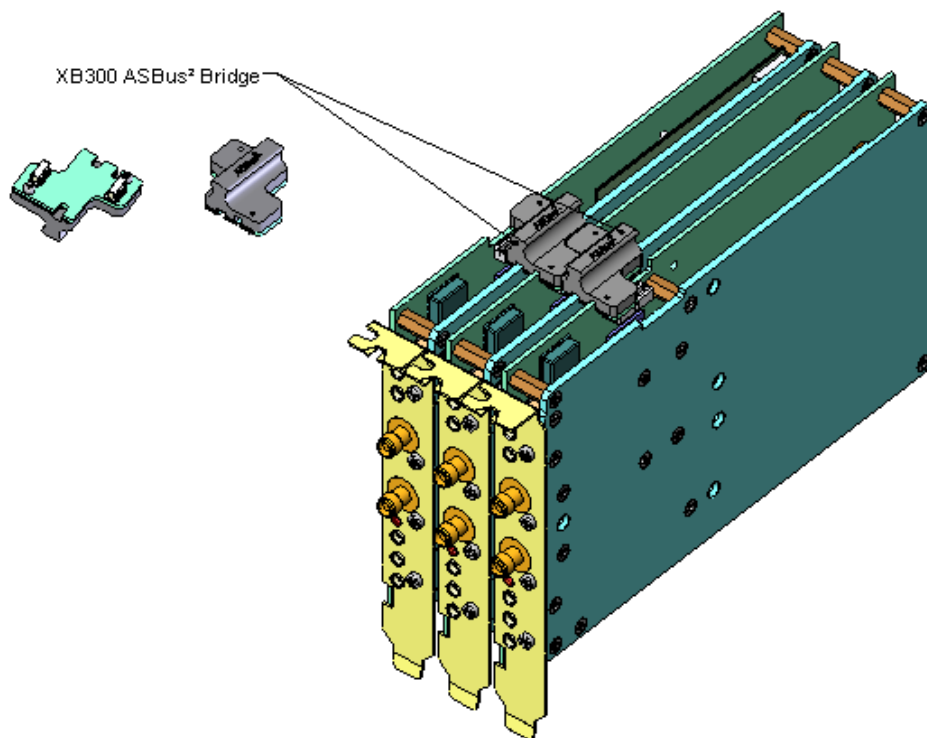

## 7. Appendix C: -BB1 Battery Backup for CompactPCI Digitizers

### Specification and Assembly Instructions -BB1 Option

#### SPECIFICATIONS :

Time to charge the battery : <2.5 h (digitizer powered)

Backup duration time : without long memory option : >120 h  
with long memory option : >12 h

Lifetime : 75% of battery capacity after 500 cycles

Note: This option is available for U1063A, U1064A, U1065A, and U1066A series digitizers.  
It was formerly known as XA001

Please refer to the Programmer's Guide for more detailed information on the use of the battery backup.

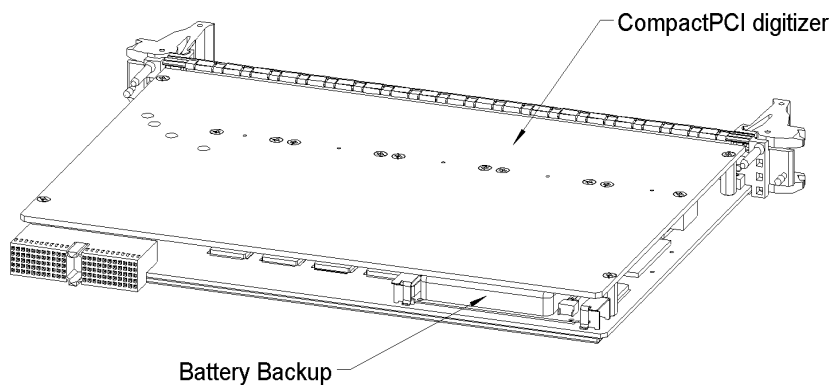

**CAUTION:** *The CompactPCI digitizer must always be powered off before either introducing or removing the battery backup and care must be taken in order to avoid electrostatic discharges.*

#### INSTALLATION AND REMOVAL OF THE BATTERY BACKUP

The following steps are necessary to install the battery backup into a CompactPCI digitizer :

1. Position the battery backup between the guides "A" and "B" ensuring that the orientation matches the figure below.
2. Lift the two strips "C" and "D" in order to introduce the circuit board of the battery backup into the guides "A" and "B".
3. Push the battery backup in the direction of the card until it hits the stop blocks and ensure that the strips "C" and "D" are correctly and securely attached.

Proceed in the reverse order to remove the battery backup.

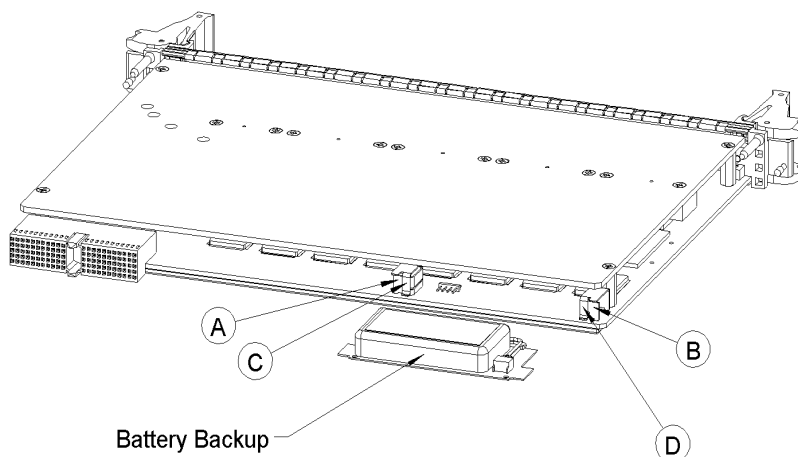

**PROCEDURE FOR REPLACING THE BATTERY:**

1. Disconnect the battery connector A from the PCB connector B.
2. Remove the battery 3.
3. Remove the label 4.
4. Reglue this label on the new battery, respecting the direction of the text.
5. Change the adhesive film 2.
6. Reconnect the new battery, connector A to connector B on the PCB.
7. Restick the new battery by pressing it onto the PCB; ensure that it holds well.

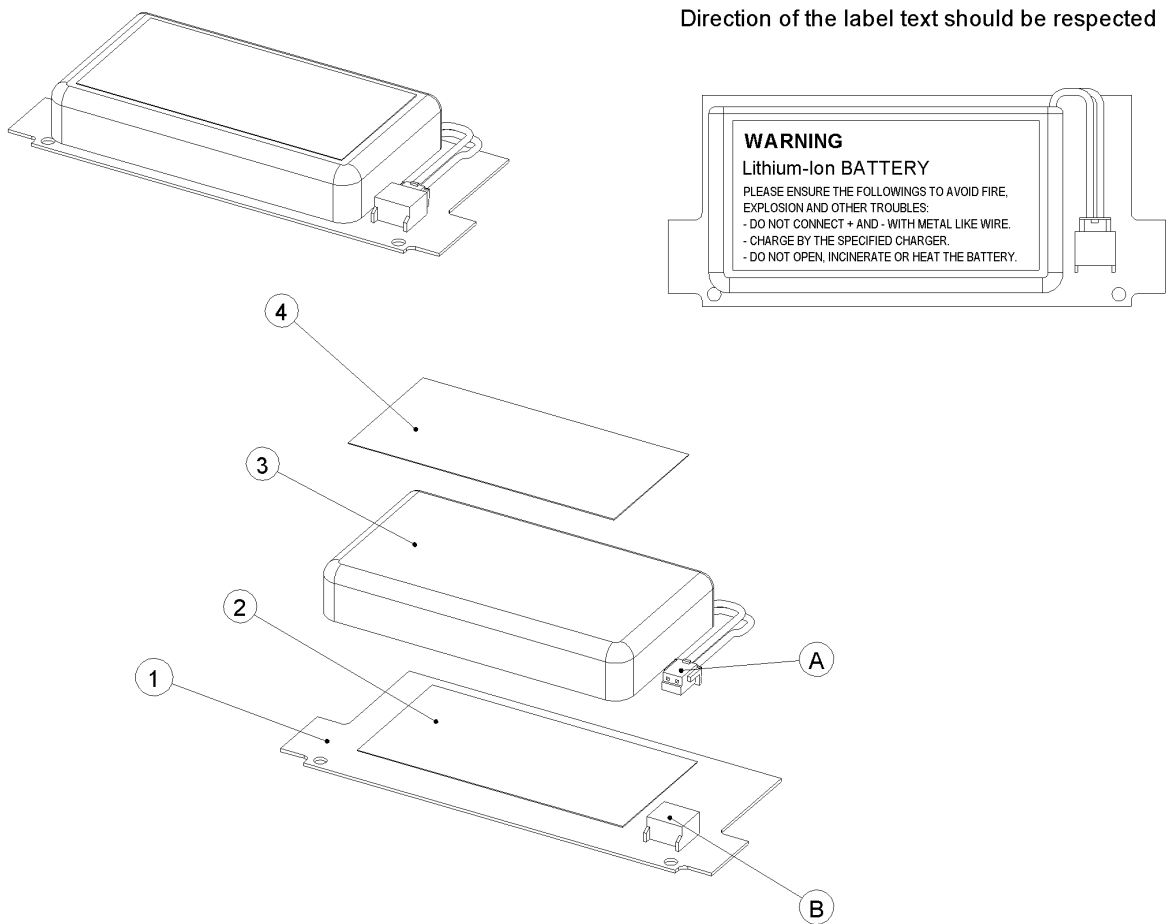

Pos	Supplier	Description	Manufacturer N°
1	Agilent	PCB battery back-up	A01-MP030040A
2	3M	Adhesive transfer tape 5mil 22mmx45mm	468MP
3	Sanyo	LithiumIon 3.7V 650mAH 4.2V 27.3x50.5x8.6mm	UF311/C
4	Agilent	45x22mm polycarbonate red, A4 sheet, 52 labels	A01-GL010002A

## 8. Appendix D: U1092A-HVB XA100 BNC Input Overvoltage Protection Specifications and User Instructions

The XA100 Acqiris option contain two elements :

- 3dB BNC Attenuator
- 90V BNC Spark Gap

The XA100 overvoltage protection kit allows the digitizers with 50 Ohm only input (without high impedance input) to withstand a high voltage surge of up to 5 kV.

### XA100 SPECIFICATIONS :

- Frequency range : DC to 1GHz
- Input impedance : 50 Ohm
- Attenuation : 3 dB
- VSWR, DC to 1GHz : < 1.25
- Impulse discharge current (8/20 us pulse) : 10 kA
- Weight : 60 g
- Length : 85 mm

### ATTENTION :

- **BOTH** the 90V spark gap and the 3dB attenuator **MUST** be used in order to absorb very high current.
- In order to limit the input current, the attenuator **MUST** be inserted between the spark gap and the input of the module, as shown in the figure below.

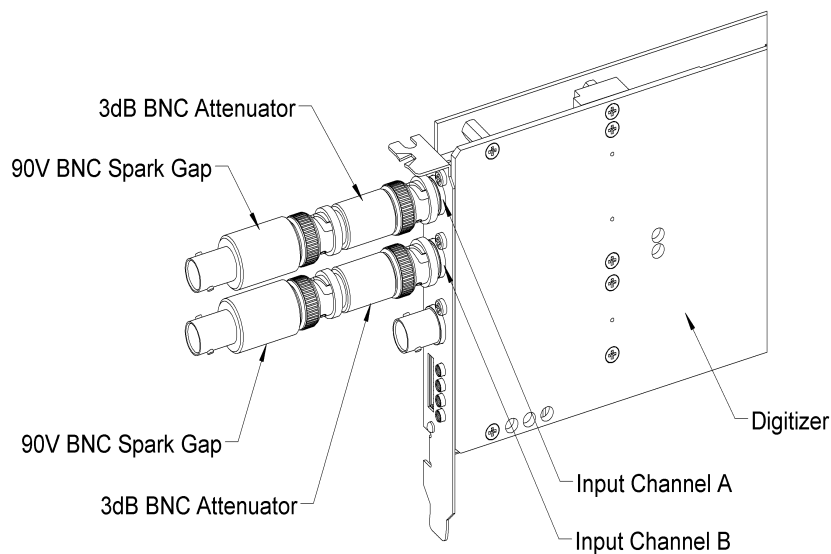

## 9. Appendix E: U1091AX01 XP100 Fan Unit for DP1xx/DP2xx units

### Specification and Assembly Instructions - XP1 Option

#### SPECIFICATIONS :

Airflow : 6 m<sup>3</sup>/h, typical speed 6000 rpm, maximal noise 35 dB(A).

Nominal Voltage : 5 VDC.

Power input : 0.8 W.

With electronic protection against reverse polarity, impedance-protected against blocking and overloading.

Operating temperature : 0 °C to 70 °C.

Life expectancy (at 25 °C) : 45000 hours.

Safety approvals : CE, VDE, UL, and CSA.

Materials : Box of stainless steel and fan of fiberglass reinforced plastic, PBT housing, PA impeller.

#### HOW TO INSTALL/REMOVE THE FAN UNIT ON A DIGITIZER :

1. Remove the digitizer from the PC, prior to installing or removing the fan unit.
2. Unscrew the screw of the retaining clips on each side of the fan unit.
3. Twist the fan's cable a few times in order for the 2 wires to stay together.
4. Introduce the cable between the spacers "A" and "B" at the back of the digitizer.
5. Push the fan unit into the back of the digitizer until the fan's box is in contact with the digitizer cover.
6. Place the two retaining clips on the spacers "A" and "B" and screw again the two screws. Insure that the fan unit is safely attached on the two spacers.
7. Connect the fan's cable as shown in the figure below. The position of the power connector can vary for different model of digitizers.
8. To remove the fan unit, first unplug its power cable and next unscrew and remove the two retaining clips. Pull the fan unit away from the digitizer.

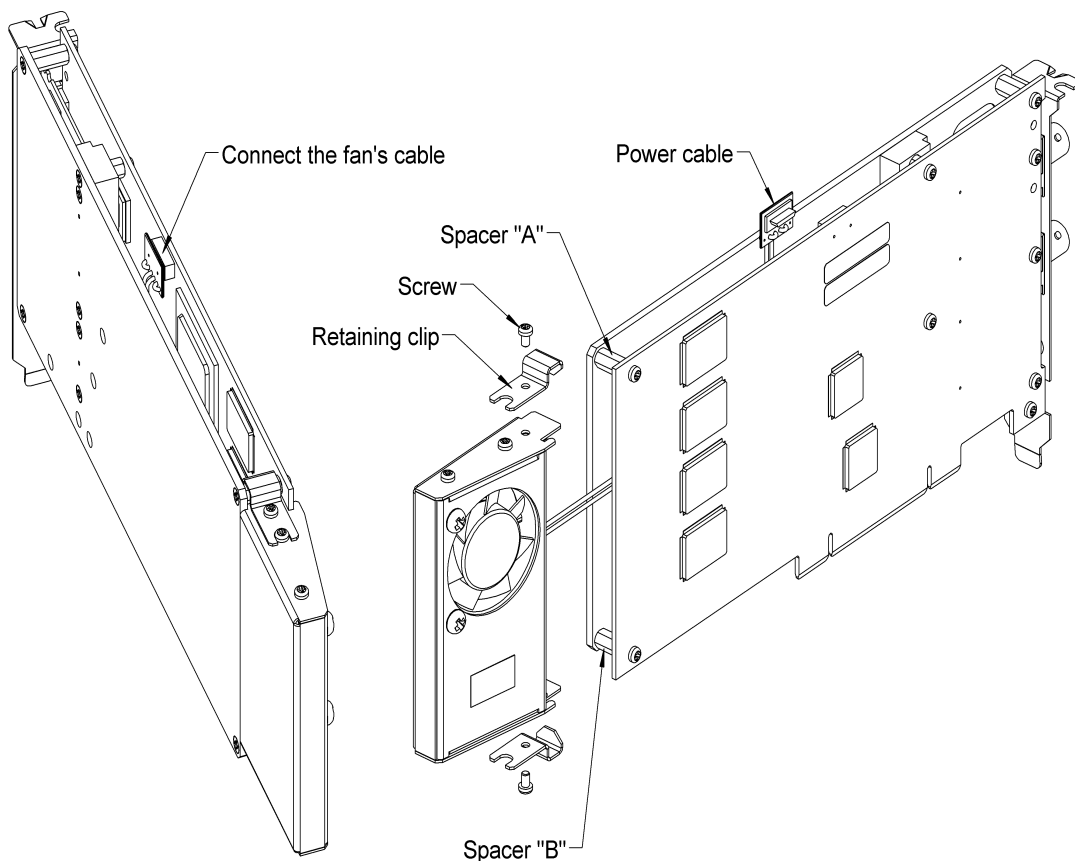

## 10. Appendix F: XP101 Fan Unit for DP Digitizers (Obsolete)

### Specification and Assembly Instructions

#### SPECIFICATIONS :

Airflow : 16 m<sup>3</sup>/h, typical speed 6500 rpm, maximal noise 30 dB(A).

Nominal Voltage : 5 VDC.

Power input : 2.1 W.

With electronic protection against reverse polarity, impedance-protected against blocking and overloading.

Operating temperature : 0 °C to 70 °C.

Life expectancy (at 25 °C) : 50000 hours.

Safety approvals : CE, VDE, UL, and CSA.

Materials : Box of stainless steel and fan of fiberglass reinforced plastic, PBT housing, PA impeller.

#### HOW TO INSTALL/REMOVE THE FAN ON A DIGITIZER :

1. Remove the digitizer from the PC, prior to installing or removing the fan unit.
2. Twist the fan's cable a few times in order for the 2 wires to stay together.
3. Introduce the cable between the spacers "A" and "B" at the back of the digitizer.
4. Push the fan unit into the back of the digitizer so that the two springs lock into place.
5. Insure that the two springs are safely attached behind the two spacers and that the fan's box is in contact with the digitizer cover.
6. Connect the fan's cable as shown in the figure below. The position of the power connector can vary between different digitizer models.
7. To remove the fan unit, first unplug its power cable and then press on both fan springs and pull it away from the digitizer.

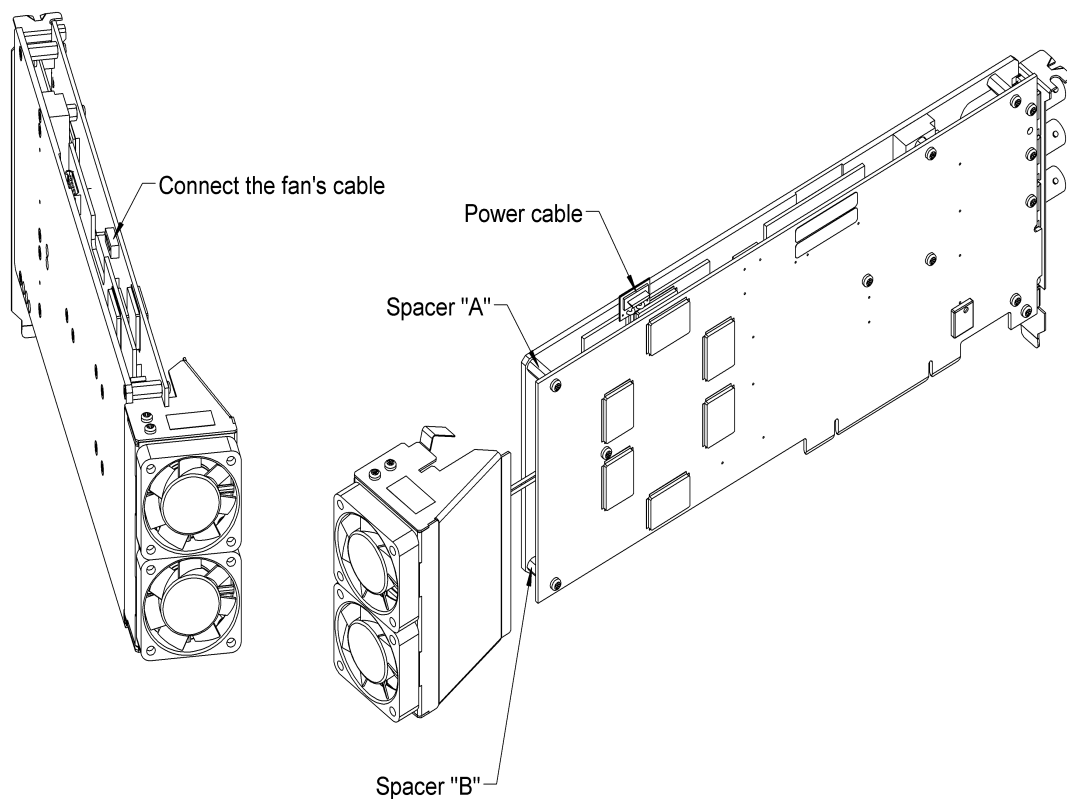

## 11. Appendix G: U1091AX03 XP103 Fan Unit for the DPxxx Modules

### Specification and Assembly Instructions - XP3 Option

#### SPECIFICATIONS :

Airflow : 16 m3/h, typical speed 6500 rpm, maximal noise 30 dB(A).

Nominal Voltage : 5 VDC.

Power input : 2.1 W.

With electronic protection against reverse polarity, impedance-protected against blocking and overloading.

Operating temperature : 0 °C to 70 °C.

Life expectancy (at 25 °C) : 50000 hours.

Safety approvals : CE, VDE, UL, and CSA.

Materials : Box of stainless steel, aluminium and fan of fiberglass reinforced plastic, PBT housing, PA impeller.

#### HOW TO INSTALL/REMOVE THE FAN ON A DIGITIZER :

1. Remove the digitizer from the PC, prior to installing or removing the fan unit.
2. Twist the fan's cable a few times in order for the 2 wires to stay together.
3. Introduce the cable between the spacers "A" and "B" at the back of the digitizer.
4. Push the fan unit into the back of the digitizer so that the two springs lock into place.
5. Insure that the two springs are safely attached behind the two spacers and that the fan's box is in contact with the digitizer cover.
6. Connect the fan's cable. The position of the power connector can vary between different digitizer models.
7. To remove the fan unit, first unplug its power cable and then press on both fan springs and pull it away from the digitizer.

#### HOW TO INSTALL/REMOVE THE DIGITIZER IN A PCI SLOT OF A PC :

1. Install the fan on the digitizer as described above.
2. Release the three screws "R" from the adjustable retainer and move the retainer against the fans.
3. Introduce the digitizer into the PCI slot and tighten the front panel screw.
4. Push the retainer into the PCI slot guide and tighten the three screws "R". The digitizer is now installed.
5. To remove the digitizer it is necessary to first release the three screws "R" and pull back the adjustable retainer.

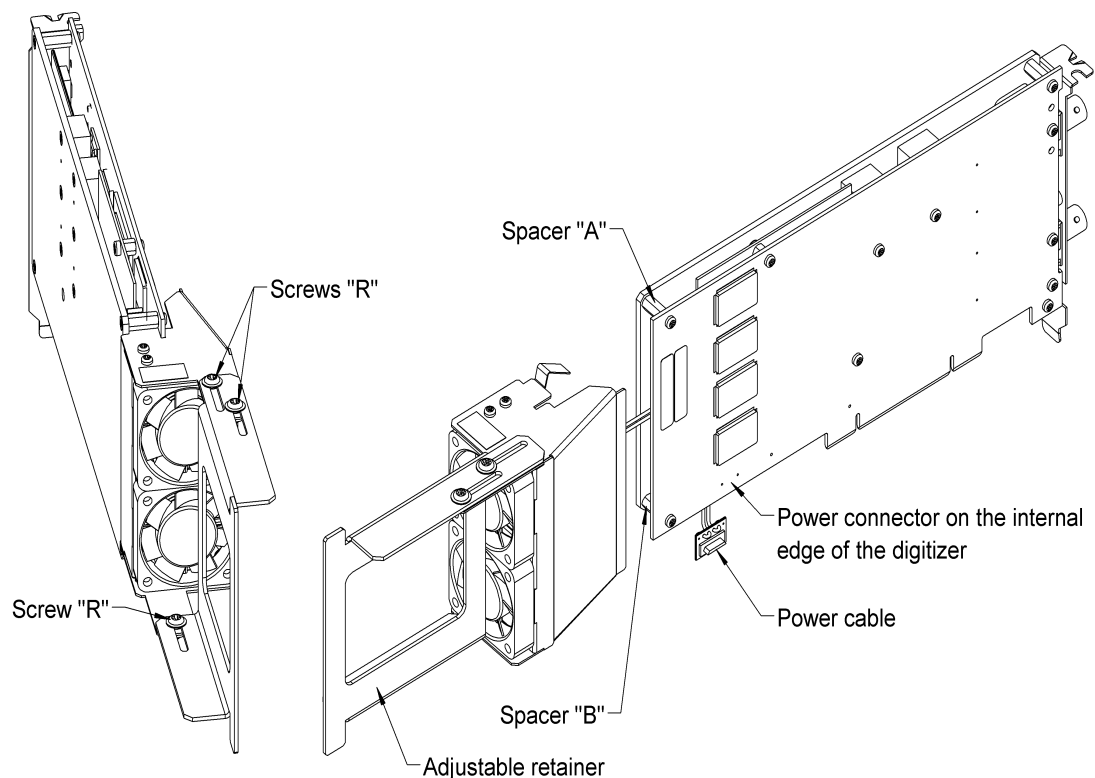

## 12. Appendix H: U1091AX04 XP104 Fan Unit for U1071A-FAMILY

### **SPECIFICATIONS:**

Airflow : 14 m<sup>3</sup>/h, typical speed 4500 rpm, maximum noise 25 dB(A).

Nominal Voltage : 5 VDC.

Power input : 1 W

With electronic protection against reverse polarity, impedance-protected against blocking and overloading.

Operating temperature : 0 °C to 70 °C.

Life expectancy (at 40 °C) : 55000 hours.

Safety approvals : CE, VDE, UL, and CSA.

Materials : Box of stainless steel, aluminum and fan of fiberglass reinforced plastic, PBT housing, PA impeller.

### **HOW TO INSTALL/REMOVE THE FAN UNIT ON A DIGITIZERS:**

(Refer to the figures on the next page)

1. Remove the digitizers from the PC, before installing or removing the fan unit.
2. Unscrew the screws "E" and "F" of the retaining clips "C" and "D" on each side of the fan unit.
3. Twist the fan's cables a few times so that the 2 wires stay together.
4. Connect the fan's cables to the Digitizer "1" connectors as shown in the figure below.  
Either cable can be connected to either connector.
5. Push the fan unit into the back of Digitizer "1" so that the two springs lock into place.
6. Place the two retaining clips "C" on the spacers "A" and "B" and insert and tighten the two screws "E".
7. Ensure that the fan unit is safely attached to the two spacers.
8. If the optional digitizer is present, install the retaining clips "D" with the screws "F".

(Refer to the figures attached on sheet 2 of 2)

### **HOW TO INSTALL/REMOVE THE DIGITIZERS IN A PCI SLOT OF A PC:**

1. Remember to cut all power and take the usual precautions against static discharges.
2. Install the fan on the digitizer as described above.
3. Loosen the two screws "R" from the adjustable retainer and move the retainer toward the fans.
4. Introduce the digitizers into the PCI slot and tighten the front panel screw.
5. Push the retainer into the PCI slot guide and tighten the two screws "R". The digitizer is now installed.
6. To remove the digitizers it is necessary to first loosen the two screws "R" and then pull back the adjustable retainer.

### **CAUTION:**

It is dangerous to transport a PC with a Digitizer installed without correct positioning of the retainer.

It is dangerous to mount a single Digitizer in position "2".



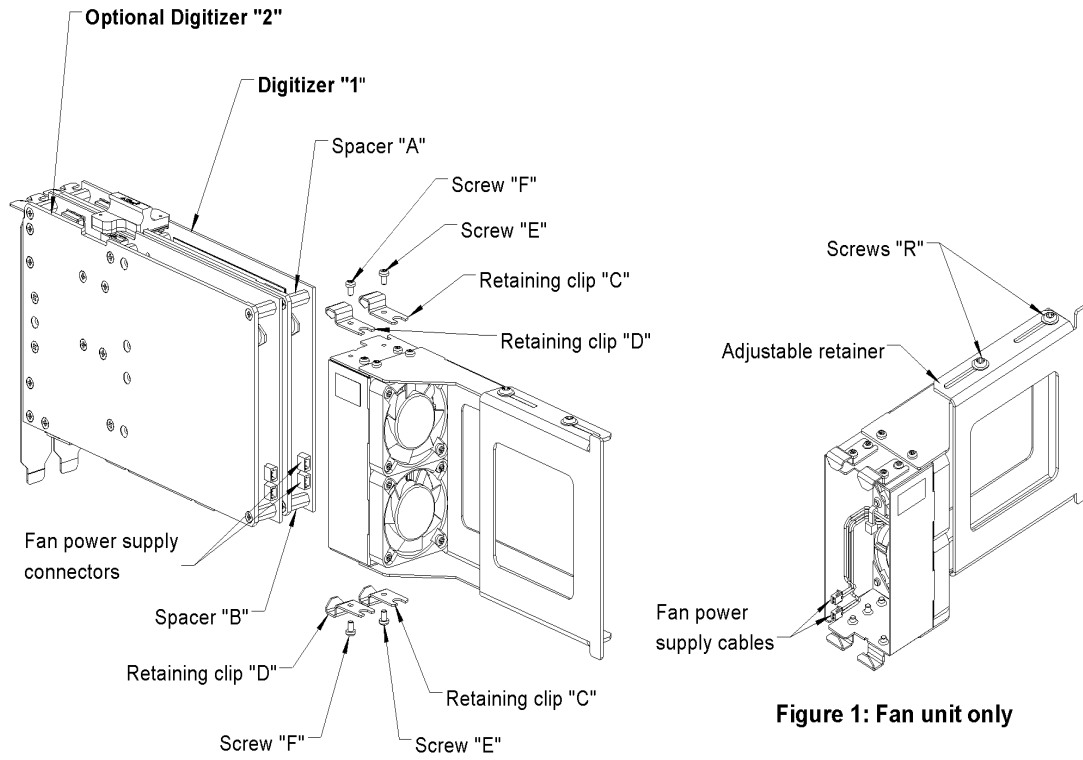

**Figure 1: Fan unit only**

**Figure 2: Exploded view of Fan unit assembly**

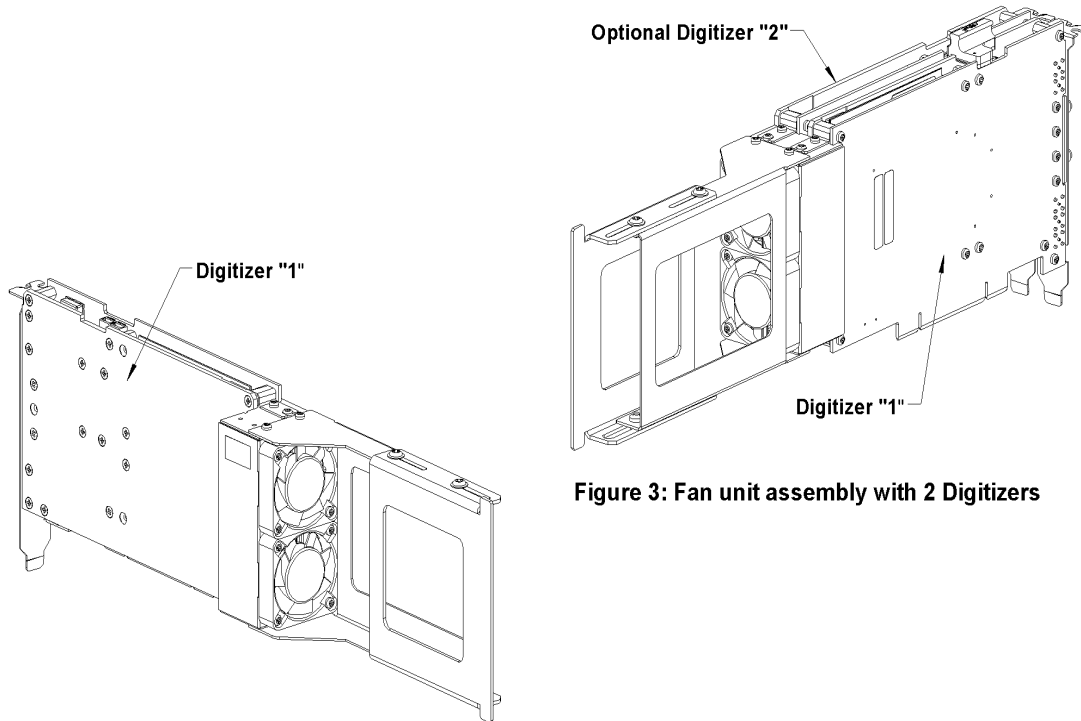

**Figure 3: Fan unit assembly with 2 Digitizers**

**Figure 4: Fan unit assembly with Digitizer "1" only**

### 13. Appendix I: U1071A-XP5(U1091AX105) XP105 Fan Unit for U1071A-FAMILY

#### SPECIFICATIONS:

Airflow : 8 m<sup>3</sup>/h, typical speed 4500 rpm, maximum noise 25 dB(A).

Nominal Voltage : 5 VDC.

Power input : 1 W

With electronic protection against reverse polarity, impedance-protected against blocking and overloading.

Operating temperature : 0 °C to 70 °C.

Life expectancy (at 40 °C) : 55000 hours.

Safety approvals : CE, VDE, UL, and CSA.

Materials : Box of stainless steel and fan of fiberglass reinforced plastic, PBT housing, PA impeller.

#### HOW TO INSTALL/REMOVE THE FAN UNIT ON A DIGITIZER:

1. Remember to cut all power and take the usual precautions against static discharges.
2. Remove the digitizer from the PC, before installing or removing the fan unit.
3. Unscrew the screw of the retaining clips on each side of the fan unit.
4. Twist the fan's cables a few times so that the 2 wires stay together.
5. Connect the fan's cables to the Digitizer connectors as shown in the figure below.  
Either cable can be connected to either connector.
6. Push the fan unit into the back of the digitizer until the fan's box is in contact with the digitizer cover.
7. Place the two retaining clips on the spacers "A" and "B" and insert and tighten the two screws.  
Ensure that the fan unit is safely attached to the two spacers.

#### CAUTION:

It is dangerous to transport a PC with a digitizer installed as shown.

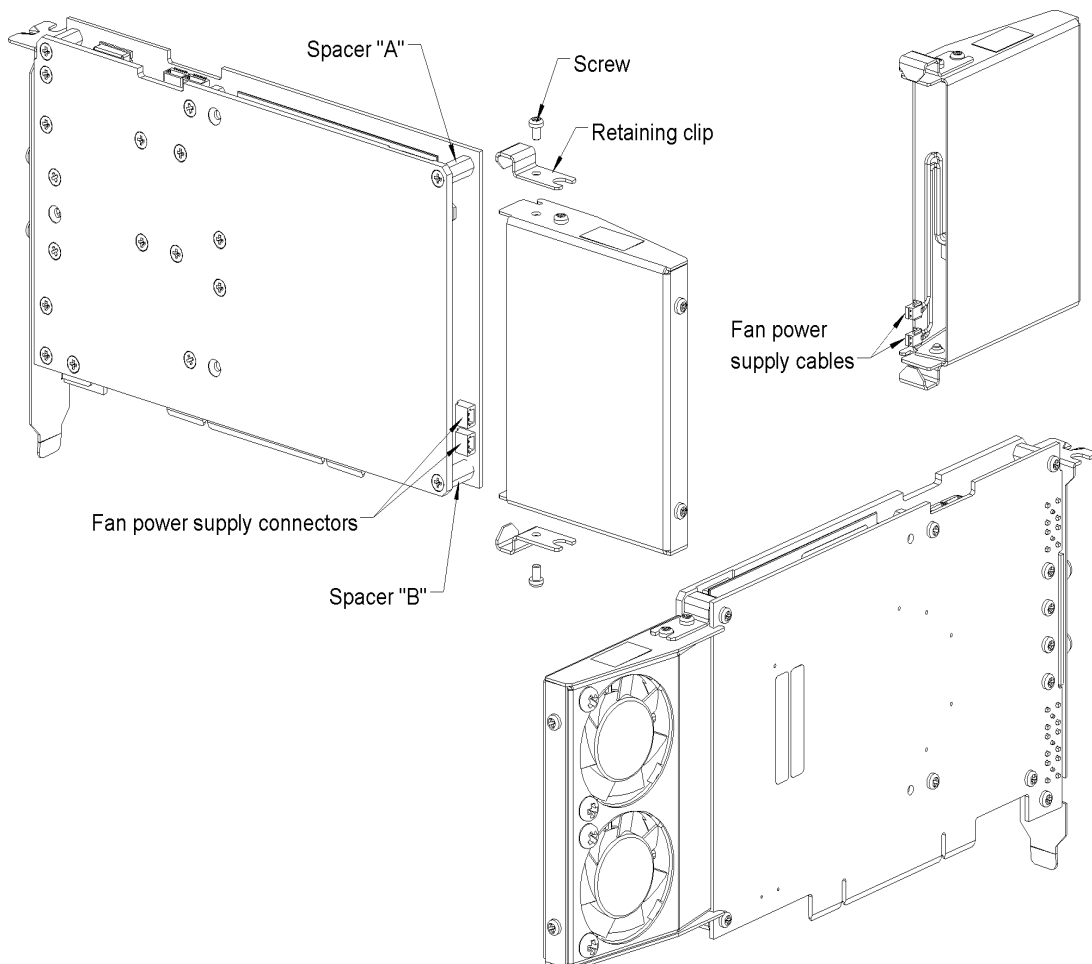

## 14. Appendix J: U1084A Fan Unit

The U1084A Digitizers are supplied with a fan unit. This fan unit is required for operation, and should not be removed.

The cooling fan assembly of the U1084A takes up 2 PC slots at the rear. It has been designed to be mounted in either a left or right orientation to allow adaptation to different PC or chassis hardware, or also to allow two U1084A modules to be positioned side-by-side.

To change the orientation, please use the following procedure:

1. Remove the 2 screws (top & bottom) nearest to the front of the fan unit, and remove the 2 retaining clips (shown pale red in the diagram).
2. Slide the fan unit approximately 15mm to the rear until it clears the circuit board, and rotate it by 180°.
3. Slide the fan unit back towards the module until it is fully seated into the locating slots.
4. Replace the 2 retaining clips, and refit and tighten the 2 screws.

To fit the module to the PC / chassis please use the following procedure:

1. Loosen (but do not remove) the 4 screws holding the rear support bracket (shown in violet in the diagram), and slide it towards the fans.
2. Insert the module into the PCIe slot of the PC or chassis, ensuring that it is fully seated into the PCIe bus connector..
3. Fit a screw to the top front panel and tighten it.
4. Fully extend the rear support bracket and ensure that it is inside the PCIe back plane rail.
5. Tighten the 4 screws.

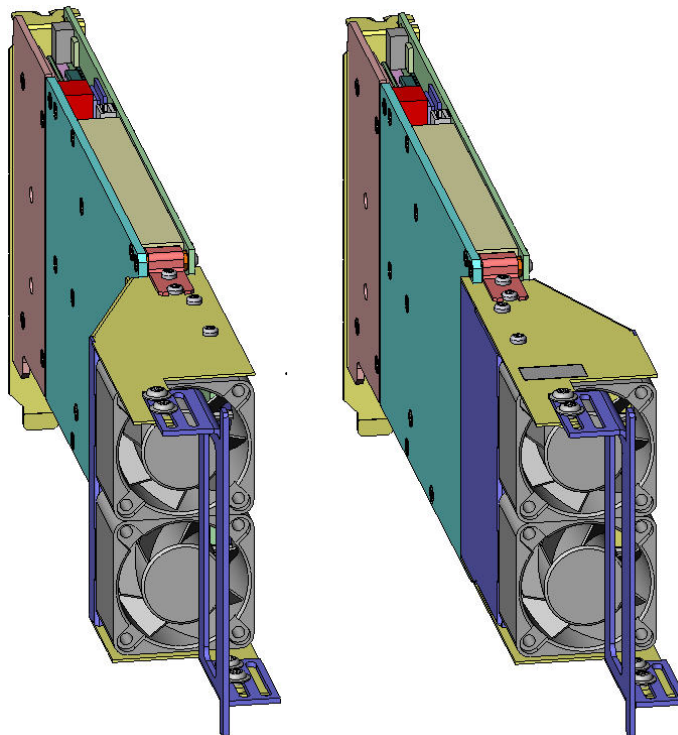

**Warning:** Both the front panel screw and the rear support bracket must be used to correctly support the unit. Failure to do this could result in damage to the unit.

**Note:** The operating temperature specifications may be found in the U1084A datasheet, however it should be noted that the onboard temperature of the U1084A should not be allowed to rise above 52°C, as performance within specifications cannot be guaranteed above this temperature.