

## TO REPLACE THE THERMOSTAT

- a) Ensure the mains supply is switched off.
- b) Remove the top and bottom grilles (2 screws per grille).
- c) Remove thermostat knob.
- d) Remove chassis (4 pan lead screws) and disconnect leads from terminal block.
- e) Disconnect the push on connectors from the faulty thermostat. Note the correct positions.
- f) Remove thermostat (2 screws).
- g) Refit new thermostat, replace connectors and re-assemble in the reverse order (g-a).

## SAFETY

This equipment has been designed and manufactured to the highest international standards, but like all electrical appliances which are operated by mains voltage, care must be taken if you are to obtain the best results and safety is to be assured.

The appliance is not intended for use by persons (including children) with reduced physical, sensory or mental capabilities, or lack of experience and knowledge unless they have been given supervision or instruction concerning use of the appliance by a person responsible for their safety.

Children should be supervised to ensure that they do not play with the appliance.

- Do NOT use this appliance in bathrooms or where similar conditions of excessive moisture are present.
- Do NOT handle the appliance with wet hands.
- Do NOT use the appliance in an enclosed room so small that the heater will generate ambient temperatures in excess of 30°C.
- Do NOT use the appliance with young children unattended.
- Do NOT use the appliance in workshops or rooms where excessive dust is generated or present.
- Do NOT touch outlet grille when appliance is in use.
- Do NOT cover or restrict any aperture of the appliance when in use.
- Do NOT use the appliance if damaged.

If the appliance has been kept in freezing conditions, run at cold/fan setting for 5 minutes before using heat settings.

This appliance meets the requirements of EU Directive 98/336/EEC for EMC.

## GUARANTEE

This guarantee is offered to you as an extra benefit and does not affect your legal rights.

All electrical appliances produced for the Company are guaranteed for one year against faulty material or workmanship. This applies only if the appliance has been used for purposes in accordance with the instructions provided and has not been connected to an unsuitable electricity supply, or subject to misuse, neglect, damage or modified or repaired by any person not authorised by us.

The correct electricity supply voltage is shown on the rating label attached to the appliance. Please retain your receipt as proof of purchase.

## CUSTOMER HELPLINE

Should you need any advice on the use of your new Consort product, or should you require service or repair, please contact our Helpline:

**☎ 01646 692172** Mon to Fri 8.30 am to 3.30 pm

**Consort Equipment Products Limited**

Thornton Industrial Estate, Milford Haven, Pembrokeshire, SA73 2RT

Fax: 01646 69519

Email: [enquiries@consortepl.com](mailto:enquiries@consortepl.com)

Web: [www.consortepl.com](http://www.consortepl.com)

# CLAUDGEN

INSTALLATION, OPERATION AND MAINTENANCE INSTRUCTIONS FOR

## FLOW ZONE

### 3 kW LOW LEVEL FAN HEATERS

Catalogue Numbers HE6137 and HE6139



Models: HE6137 - 240V 3 kW

He6139 - 240V 3 kW + Timer

**PLEASE RETAIN THIS LEAFLET FOR FUTURE MAINTENANCE**

## INSTALLATION

Ensure the electricity supply is disconnected from any relevant fixed wiring before commencing the installation. The supply circuit must be adequate for the input of the appliance and must be protected by a 13 Amp fuse. The heater must not be located immediately below a fixed socket outlet.

## PROCEDURE

1. Remove top grille (2 screws).
2. Mark screw fixing positions on wall in accordance with dimensions shown on the diagram. The unit must be screwed to the wall with 3 screws, through the holes provided in the back panel. Drill 3 holes in wall to suit No. 10 wood screws (round head) and insert rawlplugs. The two corner screws can now be screwed in until the heads are approximately 11.0mm from wall. The unit can be hung on these 2 screws, while the centrally placed screw is positioned. Before finally tightening all 3 screws ensure the unit is truly horizontal.
3. Refit top grille.

## CONTROLS

When the Appliance is connected to the mains supply and the wall socket switched 'ON' the mains neon indicator will light, showing that the power is available to the unit.

All heaters are fitted with a thermostat. To set the thermostat to the required temperature turn the control knob fully clockwise. When desired room temperature is reached, turn the knob slowly anticlockwise and when the thermostat 'clicks' off, leave the control at this setting. Thereafter, the heater controls the heat output automatically.

## USING THE TIMER (MODEL HE6139)

The heater must be connected to the mains supply in order for the timer to operate continuously. The mains neon indicates, when lit, that power is available.

Set the correct time on the timer by rotating the dial clockwise until the correct time is adjacent to the arrow.

## AUTOMATIC OPERATION

1. Switch the rocker switch immediately beneath the timer to the position designated 'Auto'.
2. The 24 hour timer can be set to give any combination of On/Off intervals to a minimum of 15 minutes on. Select the 'On' time required by pressing the black segment (on the circumference of the timer) adjacent to the time required, away from the centre of the dial. This will cause the heater to switch 'On' at the selected time for 15 minutes. Each additional segment pressed out will give a further 15 minutes of operation. In this way select the length of time required for the unit to be 'On' and push out the number of 15 minute segments necessary to select the time period required.
3. The timer can be set to give as many 'On' periods as required during any 24 hour period.
4. This programme will repeat itself every 24 hours until changed. This programme may be over-riden at any time by switching to manual operation.

**NOTE: FOR SAFETY, THE GRILLE MUST BE FITTED**

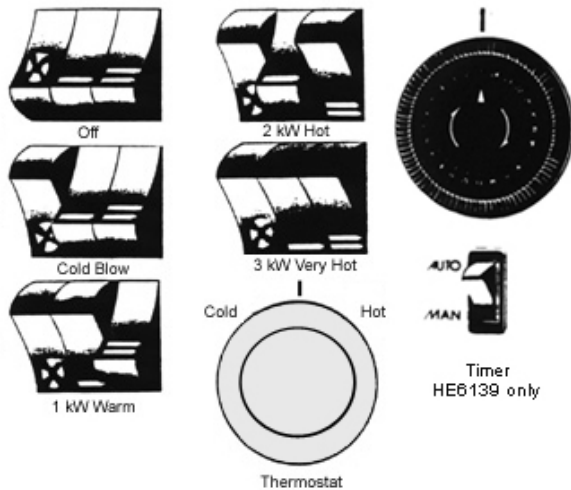
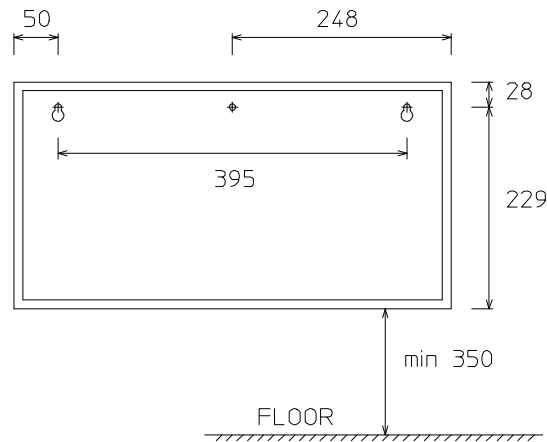

## MANUAL OPERATION

Switch the rocker switch immediately beneath timer to the position designated 'Manual'. The convector will now run continuously, controlled by the heat settings and thermostat as described under controls.

## CONNECTION TO THE MAIN SUPPLY

Electrical installation should be carried out by a competent installer, in accordance with the 17 edition of the IEE Wiring Regulations, (BS.7671: 2008), and any relevant Local Authority Bye-Laws.

This heater is fitted with a 3-core mains supply cable and should be permanently connected to the electricity supply via a double pole switch having 3mm gap on each pole.

A switched Fused Connection unit to BS.1363. Part 4 is a recommended mains supply connection accessory to ensure compliance with safety requirements applicable to fixed-wiring installation.

## MAINTENANCE

ALWAYS ENSURE THAT THE MAIN EXTERNAL ELECTRICAL SUPPLY IS SWITCHED OFF BEFORE ANY MAINTENANCE IS CARRIED OUT.

To obtain the best results from the heater, it is necessary to avoid any accumulation of dust or dirt within the unit or on the air inlet grille. The unit should be cleaned regularly.

If the supply cord on this appliance is damaged, it must be replaced by a special cord which is only available from an Authorised Service Agent or your supplier. Part number: 58000164

## PROTECTION (THERMAL CUT-OUT)

The unit is protected in the event of fan failure, or an obstruction of the free air flow, by a single thermal PTC Self Hold Cut-out. Having tripped the PTC Cut-out remains open, effectively switching off the heating elements as long as mains power is available inside the appliance. The Cut-out will only reset when the appliance is switched OFF and allowed to cool for at least 20 minutes.

## TO RESET THE PTC SELF HOLD CUT-OUT

DO NOT ADJUST BY HAND ANY INTERNAL COMPONENTS:

- a) The Cut-out is reset by switching OFF mains power to the appliance.
- b) Allow the appliance to cool for 20 minutes.
- c) Restart, switch ON the appliance. If the Cut-out trips again a qualified electrician should be called.

## TO REPLACE THE FAN/HEATER UNIT

- a) Ensure that the mains supply is switched off.
- b) Remove the top and bottom grilles (2 screws per grille).
- c) Remove chassis (4 pan head screws) - disconnect leads from terminal block.
- d) Remove front panel (4 hexagon headed screws).
- e) Disconnect the push connectors from the heater and motor leads from relevant switch. Note the correct positions.
- f) Remove the 4 pan head heater fixing screws. The blower/heater can now be lifted out of the unit.
- g) Fit replacement blower/heater and re-assemble in the reverse order (g-a).

## TO REPLACE A SWITCH

- a) Ensure the mains supply is switched off.
- b) Remove the top and bottom grilles (2 screws per grille.).
- c) Remove chassis (4 pan head screws) and disconnect leads from terminal block.
- d) Disconnect the push on connectors to the faulty switch. Note the correct positions.
- e) Depress the plastic tabs on the back of the switch and ease out through the cut-out.
- f) Insert new switch, replace connectors, and re-assemble in the reverse order (f-a).