

Network Camera

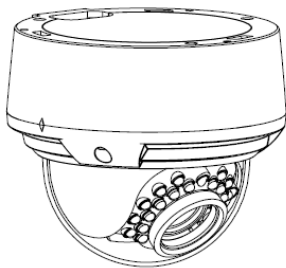

User's Manual

V1.4

--Content--

CHAPTER 1 PROFILE.....	- 2 -
1.1 FUNCTIONS AND CHARACTERISTICS.....	- 2 -
1.2 APPLICATIONS.....	- 3 -
CHAPTER 2 INSTALLATION.....	- 3 -
2.1 CAUTIONS.....	- 3 -
2.2 MEASUREMENTS.....	- 4 -
2.3 COVER REMOVAL AND ATTACHMENT.....	- 5 -
2.4 HARDWARE CONNECT.....	- 13 -
CHAPTER 3 PARAMETER SETUP.....	- 15 -
3.1 SETUP PARAMETER BY IE BROWSER.....	- 15 -
APPENDIX.....	- 16 -

This manual is suitable for IP DOME-IR series

Chapter 1 Profile

Network Camera is a kind of embedded digital surveillance product collected traditional simulation camera and network video server. Adopts embedded Linux operation system and SOC hardware platform of Graim Corp. And has characteristics of high efficiency on system adjustment, solidified code on Flash, small bulk, high stability and reliability.

1.1 Functions and Characteristics

Basic Function

- Video compression tech: adopts H.264 video compression tech, high compression ratio with super agility handling.
- Network function: integrate TCP/IP protocols and video, alarm, voice data supported, built-in WEB browser, IE interface supported.
- Heartbeat function: host computer is able to know running state of network camera real time by heartbeat function.
- PTZ control function: control for PTZ, kinds of decoder protocols and dome cameras supported.
- Alarm function: signal parameter alarm input, on-off parameter alarm output, motion detective, video lost, mask alarm, alarm link output.
- Voice speech: two-way voice speech, one-way voice broadcast.
- POE power supply supported.
- User management: multi-level user popedom management.

Compression Handling Function

- Separate hardware compression, adopts H.264 compression standard on video compression, not only support change code ratio, but also support change frame ratio, while setting up video image quality, it's able to restrict compression bit rate of video image.
- 1920*1080p, 1600*1200p, 1280*720p, D1(PAL:704*576, NTSC:704*480), CIF(PAL:352*288, NTSC:352*240), QCIF(PAL:176*144, NTSC:240*160) supported
- OSD supported, date and time setup available.

Remote interview and transmission function

- One self-compliant 10M/100M Ethernet interface as standard accessory..
- PPPoE, DHCP, DDNS protocol supported.
- Available to set parameter, browse real time video, check network camera

state through applications or IE browser. Available to realize alarm link and save compressed bit rate through network.

- Available to realize remote upgrade and maintenance through network.

1.2 Applications

Suitable for circumstances required for network remote surveillance

- ATM, Bank Counter, Supermarket, Factory etc
- Nursing House, Kindergarten, School etc.
- Intelligentized door management system
- Intelligentized Building, intelligentized community management system
- Electricity station, telecom base station etc unmanned on duty system
- Outdoor bridge, tunnel, crossing traffic etc surveillance system
- flowing line and warehouse surveillance
- 24h surveillance to road traffic
- Remote surveillance to forest, fountain and river etc.

Chapter 2 Installation

2.1 Cautions

- Please check carefully while unpacking, be sure articles inside accordance to the list
- Please read this chapter carefully before installation
- Be sure to off all concerned power while installation
- Check power and voltage in case to damage facility because of unmatched voltage
- Installation circumstance: do not install in circumstances of high humidity or high temperature, please keep good ventilation, pay attention to defend rain, avoid installing in acute vibrate circumstance.
- In times of malfunction, do not attempt to dismantle and service the camera yourself. Please refer to qualified serving personnel to repair or contact our technical department to solve the problems.
Remark: power supply, lens and SD card optional while ex-factory.

2.2 Measurements

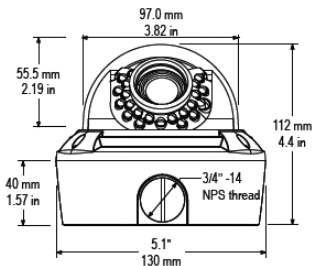

Vandal Dome Dimensions

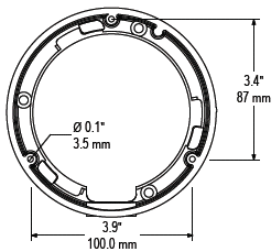

Base hole positions

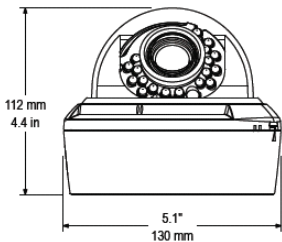

Indoor Dome Dimensions

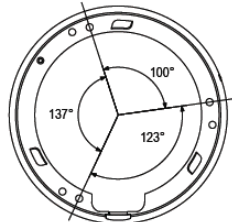

Underside Base hole positions

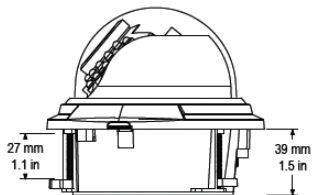

Recess Mount Fitting dimensions

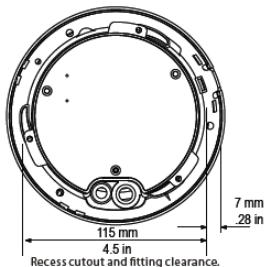

Recess cutout and fitting clearance.

2.3 Cover Removal and Attachment

2.3.1 Packing contents

Indoor Dome package contains the following:

Camera in housing -----	1
Camera Locking screws (PA3 Type) -----	2
Instruction guide (This Document) -----	1
Surface & Flush Mounting Templates -----	2
RCA - BNC test cable -----	1
Junction Box Plate -----	1
Mounting screw pack -----	1



Vandal Dome package contains the following:

Camera in housing -----	1
Camera Locking screws (PM4 Type) -----	3
Instruction guide (This Document) -----	1
Surface Mounting Template -----	1
RCA - BNC test cable -----	1
Junction Box Plate -----	1
Mounting screw pack -----	1
Tamper allen key -----	1
Conduit Key -----	1



2.3.2 Junction box plate

Junction box plate allows fitting of either Vandal dome or Indoor dome to standard 2S, 4S and Octagon junction boxes.

NOTE: Flush side of junction box plate should be attached to junction box

Junction Box fitting plate accessories:

- Junction Box Fitting plate -----1
- 2S / 4S plate screws (KM3.5 Type) -----4
- Octagon fitting screws (KM4 Type) -----2
- Base Fitting Screws PWM3 -----3

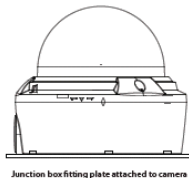
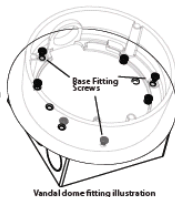
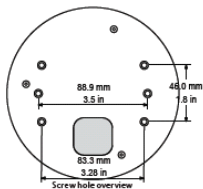

2.3.3 Junction box installation types

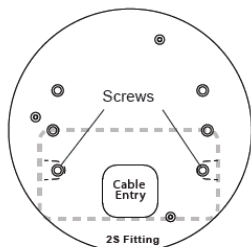

- a. 2S Fitting requires only 2pcs of base attachment screws.

Note: You have a reduced space in which to hide cables using this type of installation. Recommended for indoor dome only.

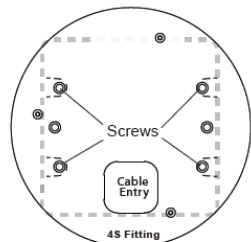

- a. 4S Fitting required 4pcs of base attachment screws.

Note: A 4S junction box provides the most robust fitting of a camera to a junction box. Suitable for both indoor and vandal domes.

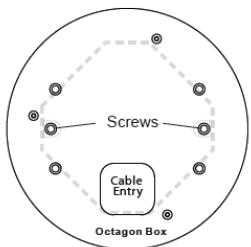

- a. Octagon Box requires only 2pcs of base attachment screws.

Note: Screws used for the octagon box are larger compared to those used for the 2S/4S (M4 type). Suitable for both indoor and vandal domes

2.3.4 Vandal dome fittings

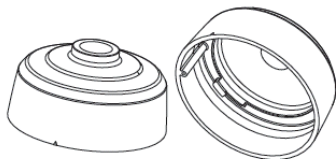

Pendant Cap - model # MNTV2XPC
Replaces the need for the camera base.
Compatible with ceiling conduit installations

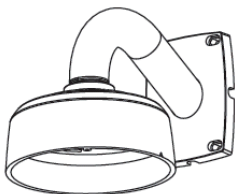

Wall Mount - model # MNTV2XW

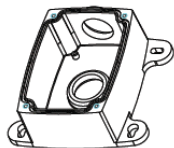

Junction Box Accessory - model # MNTV2XJ
Fits either wall mount and corner mount bracket.
Symmetrical so reversible for top or bottom conduit.

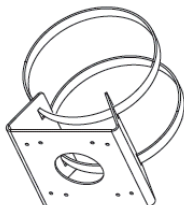

Pole Mount - model # MNTV2XP

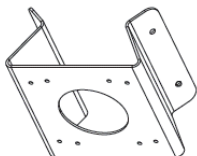

Corner Mount bracket - model # MNTV2XR
Can fit either Wall Bracket or Junction Box.

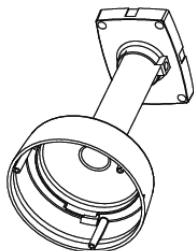

Pendant Mount - model # MNTV2XC

2.3.5 Installation vandal dome

1

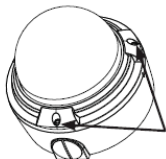

1) Remove the three tamper screws using the provided allen key. Size is standard T-15

Note: If you plan to use conduit fitting, remove conduit cap using the provided conduit key.



2

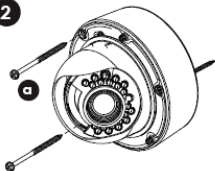

Method 1 - Direct Attach Install

2a) Use included mounting template to mark and pre-drill the required holes. Use 2pc of the 2.8" screws to mount the camera directly to the mounting surface.

Remove (one base locking screw, used for shipping purposes) and install the 3rd 2.8" screw.

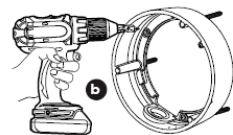

Go to step **4** on page 7 to complete installation.
OR

Method 2 - Camera Base Install

Note: Use this method if installing onto junction box plate.

2b) Remove the camera base by unscrewing the base locking screw, and turn camera module approx. 5 degrees counter-clockwise to detach camera base from the camera module. Now you install the base to the correct holes as indicated on the mount template using the 1.2" screws.

3

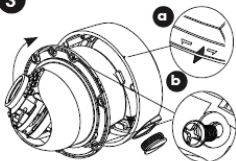

Note: If you plan on installing onto a junction box, attach provided fitting plate first to the junction box and then you attach the camera base to the fitting plate.

3a) Reinsert camera module into camera base by lining up the arrow notches, and turning camera module clockwise to lock into place.

3b) Use the supplied three base locking screws to secure camera base to camera module.

Go to step **4** on page 7 to complete installation.

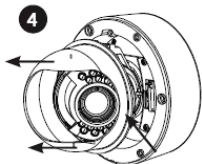

- 4) Remove camera cover by squeezing the back and front of the cover as indicated by the "PRESS" indicators at the same time and lifting it up and away from the lens.

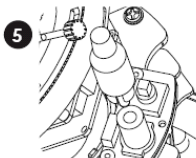

- 5) Insert the included video test cable into the RCA jack and connect to a test monitor to set up camera.

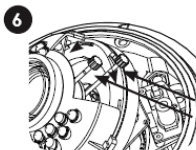

- 6a) Adjust camera viewing angle and secure into place by tightening thumb screw using a flat head screwdriver.
 6b) Adjust lens and OSD as required.
 6c) Re-attach the camera cover, using the thumb screw as a guide, until it snaps into place.

Note: Lens adjustment levers are by default in the locked position. Turn counter clockwise to unlock. Tighten levers to secure lens setting.

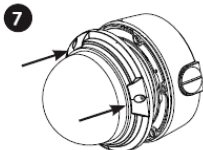

- 7a) Re-attach the camera cover. Line up arrows as shown in figure 3a on page 6 as a guide
 7b) Use the allen key to tighten the tamper screws to create a proper weatherproof seal.

Note: Make sure dome cover cord does not get caught in the rubber seal.

2.3.6 Installation indoor dome (Surface Fitting)

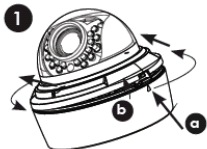

- 1a) Press down on the tab marked with an arrow to lift up the dome cover slightly
- 1b) While pressing on tab, twist the dome cover counter clockwise just a few degrees to release dome cover from back clips. Lift off the cover.

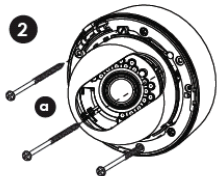

Method 1 - Direct Attach Install

- 2a) Use included mounting template to mark and pre-drill the required holes. Use included 2.8" screws to mount the camera directly to the mounting surface.

Go to step **3** on page 9 to complete installation.
OR

Method 2 - Camera Base Install

Note: Use this method if installing onto junction box plate.

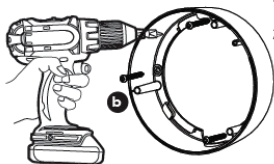

- 2b) Remove the camera base by unscrewing the base locking screws (indicated by padlock markings) and turn camera module approx. 5 degrees counter-clockwise to detach camera base from the camera module. Install the base as indicated using the 1.2" screws.

Note: If you plan on installing onto a junction box, attach provided mounting plate first to the junction box and then attach camera base to the mounting plate.

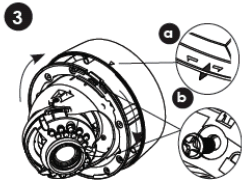

- 3a) Reinsert camera module into camera base by lining up the arrow notches, and turning camera module clockwise to lock into place.
- 3b) Reinstall the base locking screws. (indicated by padlock markings)

Go to step **3** on page 9 to complete installation.

2.3.7 Installation indoor dome (Semi-Flush Fitting)

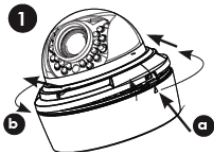

- 1a) Press down on the tab marked with an arrow to lift up the dome cover slightly
- 1b) While pressing on tab, twist the dome cover counter-clockwise to release dome cover
- 1c) Remove the camera base by unscrewing the base locking screws (indicated by a padlock markings) and turn camera module approx. 5 degrees counter-clockwise to detach camera base from the camera module.

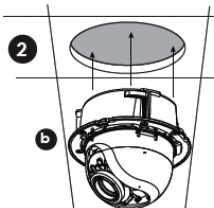

- 2a) Cut semi flush mounting hole into surface using provided flush mounting template.
Note: Always cut according to the inside of the cutout template
- 2b) Insert dome into cutout. Make sure that the mounting arms are not extended.
- 2c) Turn screwdriver clockwise to unlock all of the 3 mounting arms.
- 2d) Continue turning clockwise to move mounting arms down until they make contact with inner mounting surface.

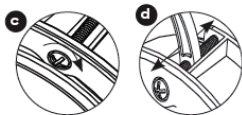

Note: Once mounting arms have made contact with the inner mounting surface, do not apply too much pressure to avoid damaging surface.



- 3a) Remove camera cover by squeezing the back and front of the cover as indicated by the "PRESS" indicators at the same time and lifting it up and away from the lens.
- 3b) Insert the included video test cable into the RCA jack and connect to a test monitor to set up camera. (see page 10)
- 3c) Adjust camera viewing angle and secure into place by tightening thumb screw using a flat head screwdriver. Adjust lens and OSD as required.

Note: Lens adjustment levers are by default in the locked position. Turn counter clockwise to unlock. Tighten levers to secure lens setting.

- 4a) Re-attach the camera cover, using the thumb screw as a guide, until it snaps into place.
- 4b) Reattach dome cover.

2.4 Hardware connect

2.4.1 Hardware interface

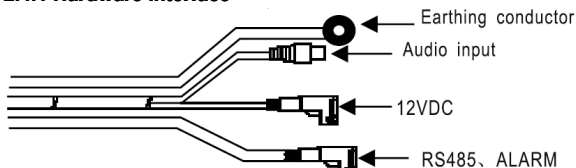

Interface	Connection
Network interface (NIC)	Connect to Ethernet device, such as Ethernet exchanger, HUB etc. See 2.3.3 for network connection.
Audio in/output	Connect to audio in/output device, such as tone arm(impedance: 1k Ω) .
Power (DC12V)	Detailed type see parameter form in "Appendix", please use matched manostat power.
Alarm output (COM OUT)	Connect to alarm output, 1 channel on-off parameter(the connected power must be within range of DC12V and 300mA), detailed connection method see 2.3.2
Alarm input (COM IN)	Connect to alarm input, 2 channels signal alarm(DC5V~DC12V) .
RS-485 interface	Connect to RS-485 device, such as Pan/Tile, PTZ etc.
Video output	1 channels BNC Video output for lens focusing.
SD card insert groove	Insert SD card for local save.
RESET	RESET button, restore ex-factory value.

2.4.2 Alarm output connection

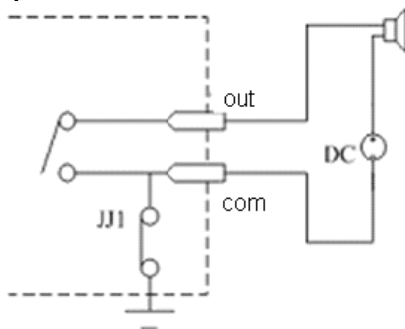

Alarm output connection demonstration



Alarm output is in fact on-off (No voltage), outside power is needed while connection alarm. Outside power must be within DC12V and 300mA while connection DC power.

2.4.3 Selection of reticle

(1) Twisted-pair to connection interface of network camera with HUB(straight connection cable)

1	white-orange		white-orange	1
2	orange		orange	2
3	white-green		white-green	3
4	blue		blue	4
5	white-blue		white-blue	5
6	green		green	6
7	white-brown		white-brown	7
8	brown		brown	8

(2) Twisted-pair to connection interface of network camera with PC(cross connection cable)

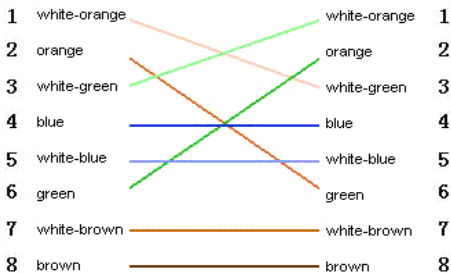

Chapter 3 Parameter setup

Some network parameters must be setup firstly after finishing installation, includes IP address, submask, port etc, can be setup through many kinds of ways, see below two kinds for examples:

1. Setup parameters such as IP address and PPPoE etc through IE browser

2. Setup parameters through applications on client's side.

Please be confirm PC and network camera already be connected, and the network camera can be PING!

3.1 Setup parameter by IE browser

The default IP:192.168.0.120, default port:30001, superuser: admin, superuser password: admin

Login network camera by IE, input IP address, and will shoot out logging in window, input username and password, click "login" to enter IE client interface.

Function detailed guide please refer to "Network Video Manager System Manual".

Important Note: to check device by IE, the premise is to set browser security level, open IE browser, enter "tool/Internet option/security/user-defined level", set security level "security level-low", or directly set "ActiveX, Widget and Insert" to open.

Appendix

Model	Parameter	Description
DPS <input type="checkbox"/>	Image Sensor	1/3" DPS(Digital Pixel System)
	Resolution	540TVL
	Minimum illumination	0.5Lux/F1.2 0Lux (LED-ON)
	S/N Ratio	≥48dB
	Image Frame Rate	PAL:D1(704x576)@25fps, CIF(352x288)@25fps, QCIF(176x144)@25fps, NTSC:D1(704x480)@30fps, CIF(352x240)@30fps, QCIF(240x160)@30fps.

Model	Parameter	Description
COMS <input type="checkbox"/>	Image Sensor	1/4" CMOS
	Resolution	450TVL
	Minimum illumination	0.3Lux/F1.2 0Lux (LED-ON)
	S/N Ratio	≥45dB
	Image Frame Rate	PAL:D1(704x576)@25fps, CIF(352x288)@25fps, QCIF(176x144)@25fps; NTSC:D1(704x480)@30fps, CIF(352x240)@30fps, QCIF(240x160)@30fps.

Model	Parameter	Description
High Resolution CCD <input type="checkbox"/>	Image Sensor	1/3" Sony Super HAD II CCD
	Resolution	540TVL
	Minimum illumination	0.008Lux/F1.2 0Lux (LED-ON)
	S/N Ratio	≥48dB
	Image Frame Rate	PAL:D1(704x576)@25fps, CIF(352x288)@25fps, QCIF(176x144)@25fps; NTSC:D1(704x480)@30fps, CIF(352x240)@30fps, QCIF(240x160)@30fps.

Model	Parameter	Description
Low Resolution CCD <input type="checkbox"/>	Image Sensor	1/3" Sony CCD
	Resolution	500TVL
	Minimum illumination	0.03Lux/F1.2 0Lux (LED-ON)
	S/N Ratio	≥50dB
	Image Frame Rate	PAL:D1(704x576)@25fps, CIF(352x288)@25fps, QCIF(176x144)@25fps; NTSC:D1(704x480)@30fps, CIF(352x240)@30fps, QCIF(240x160)@30fps.

Model	Parameter	Description
1.3 MP CCD □	Image Sensor	1/3" Ex-view 1.3Mega Pixel CCD
	Minimum illumination	0.5Lux @ F1.2 0Lux (LED-ON)
	S/N Ratio	≥48dB
	Image Frame Rate	PAL:1280x720p@25fps NTSC: SXGA(1280x960p)@22.5fps

Model	Parameter	Description
1.3 MP CMOS □	Image Sensor	1/3" MT9M033 COMS
	Minimum illumination	0.5Lux @ F1.2 0Lux (LED-ON)
	S/N Ratio	≥48dB
	Image Frame Rate	PAL:1280x720p@25fps NTSC: SXGA(1280x960p)@22.5fps

Model	Parameter	Description
2 MP CCD □	Image Sensor	1/1.8" SONY Progressive Scan CCD
	Minimum illumination	0.5Lux/F1.2 0Lux (LED-ON)
	S/N Ratio	≥48dB
	Image Frame Rate	1600x1200p@15fps

Model	Parameter	Description
2 MP CMOS 	Image Sensor	1/2.5" MT9P031 CMOS
	Minimum illumination	0.5Lux/F1.2 0Lux (LED-ON)
	S/N Ratio	≥48dB
	Image Frame Rate	PAL:1920x1080p@25fps NTSC:1920x1080p@30fps

Parameter	Description
Video out	1 BNC (PAL/NTSC, 1.0Vp-p, 75Ω)
Video Compression	H.264(ISO/IEC 14496-10)/MJPEG
Bit stream Control	CBR、VBR
Audio Input/Output	1 internal Microphone In, 1 External Microphone In, 1 Audio Line Out
Audio Compression	G711/8KHz, 16bits
	G723.1/6.3kbps (Options) AMR (Options)
Audio bit stream	6.3Kbps
OSD	Time/date/channel NO./ channel name/user-defined
Audio and video sync	Support

Motion detection	Support
Heartbeat	Support
Two-way voice talkback	Support
Alarm and event handling	Through built-in dynamic detection or external input or planned to trigger the events; Through FTP, Email and HTTP uploading images and issued a notice
Network transmission control	Embedded network bandwidth adaptive flow control technology
Web Server	Microsoft Internet Explorer Version 5.5 or higher
Network Protocol	IPv4/v6、RTP/RTCP、TCP/UDP、HTTP、DHCP、DNS、FTP、DDNS、PPPOE、SMTP
Network Ethernet	RJ-45,10/100Base-T
Alarm Input/Output	1 Alarm Input, 1 Alarm Output
RS485	1 Output (1 Input Options)
IR-LED	850nm×21 Pcs IR-LED
IR-LED Driver	ON 1~3Lux; OFF 5~8 Lux
SD Card	Support MicroSD/HC, MiniSD/HC
Safely	Watchdog, Password protection
Temperature (°C)	-10-60 °C, RH10-90% (RUN) -20-70 °C, RH0-95% (STORE)

Supplied Voltage	9~12VDC \pm 5%, 1000mA
POE	802.3af POE(Power over Ethernet)
CMS Client and SDK	Open API for application integration including SDK