



MANUAL INSERT

Model G0574

Radiusing Sander

INTRODUCTION

The Model G0574 Radiusing Sander is based on the Model G1140 Edge Sander with the addition of the radiusing attachment. Refer to the G1140 Edge Sander manual for the sanding unit assembly instructions and refer to the included G0577 Radiusing Attachment manual for radiusing attachment installation instructions. The Model G0574 DOES NOT include the work table, auxiliary table, and miter body listed in the manual of the G1140. These parts are unnecessary when the radiusing attachment is installed. The inventory for the G0574 is as follows:



Figure 1. Model G0574.

Model G0574 Parts:

- Sanding Unit..... 1
- Quick Release Lever..... 1
- Dust Port 1
- 6" X 80" Sanding Belt 1
- Back Stop..... 1
- Feet 4
- Long Support Bracket 1
- Short Support Bracket..... 1
- Guide Rail A 2
- Guide Rail B 4
- Radius Control Swing Arm Assembly 1
- Horizontal Adjustment Tubes 2
- Locking Plate A 2
- Locking Plate B 4
- Brace 1
- Height Adjustment Arms 2
- Idler Roller Cover 1

Model G0574 Hardware Bag:

- Shim 1
- Hex Bolt $\frac{5}{16}$ "-18 x $2\frac{1}{2}$ " 3
- Hex Bolt $\frac{3}{8}$ "-16 x 1" 3
- Flat Washer $\frac{3}{8}$ " 11
- Flat Washer $\frac{5}{16}$ " 6
- Hex Nut $\frac{5}{16}$ "-18 3
- Hex Bolt $\frac{3}{8}$ "-16 x 2 2
- Hex Nut $\frac{3}{8}$ "-16..... 2
- $\frac{7}{32}$ " Hex Wrench..... 1
- 12-14mm Open End Wrench..... 1
- 2mm Hex Wrench 1
- Phillips® Hd Screw 10-24 X $\frac{3}{4}$ " 4

NOTICE

When ordering parts for the Model G0574 Radiusing Sander, refer to the G1140 manual for sanding unit components, and refer to the G0577 manual for radiusing attachment components.

Grizzly **Industrial, Inc.**®

EDGE SANDER MODEL G1140 INSTRUCTION MANUAL



COPYRIGHT © 1996 BY GRIZZLY INDUSTRIAL, INC.
**WARNING: NO PORTION OF THIS MANUAL MAY BE REPRODUCED IN ANY SHAPE
OR FORM WITHOUT THE WRITTEN APPROVAL OF GRIZZLY INDUSTRIAL, INC.**
REVISED APRIL, 1999. PRINTED IN U.S.A.



WARNING!

Some dust created by power sanding, sawing, grinding, drilling, and other construction activities contains chemicals known to the State of California to cause cancer, birth defects or other reproductive harm. Some examples of these chemical are:

- **Lead from lead-based paints.**
- **Crystalline silica from bricks, cement and other masonry products.**
- **Arsenic and chromium from chemically-treated lumber.**

Your risk from these exposures varies, depending on how often you do this type of work. To reduce your exposure to these chemicals: Work in a well ventilated area, and work with approved safety equipment, such as those dust masks that are specially designed to filter out microscopic particles.

Table Of Contents

	PAGE
1. SAFETY RULES	
SAFETY RULES FOR POWER TOOLS	1-2
SAFETY RULES FOR SANDERS	3
2. CIRCUIT REQUIREMENTS	
220V/110V OPERATION.....	4
CIRCUIT LOAD	4
GROUNDING	4
EXTENSION CORDS	5
WIRING DIAGRAM	5
3. GENERAL INFORMATION	
COMMENTARY	6
UNPACKING	7
PIECE INVENTORY	7
CLEAN UP.....	8
SITE CONSIDERATIONS	8
4. ASSEMBLY	
BEGINNING ASSEMBLY	9
FEET	9
WORKING TABLE	10-11
MITER BODY	12
QUICK RELEASE LEVER.....	12
AUXILIARY TABLE	13
DUST HOOD	13
BACK STOP	14
BELT INSTALLATION	14
5. ADJUSTMENTS	
BELT TRACKING	15
AUXILIARY TABLE	15
TABLE TILT.....	16
TABLE HEIGHT.....	16
PLATEN TILT	17
BELT TENSION.....	17
6. OPERATIONS	
TEST RUN.....	18
EDGE & END SANDING.....	18
HORIZONTAL SANDING	19
CONTOUR SANDING	19
7. MAINTENANCE	
GENERAL	20
LUBRICATION	20
TABLE	21
8. CLOSURE.....	21
MACHINE DATA	22
WIRING DIAGRAM	23
PART BREAKDOWN	24
PART LISTS	25
WARRANTY AND RETURNS.....	26

SECTION 1: SAFETY

WARNING

For Your Own Safety Read Instruction Manual Before Operating This Equipment

The purpose of safety symbols is to attract your attention to possible hazardous conditions. This manual uses a series of symbols and signal words which are intended to convey the level of importance of the safety messages. The progression of symbols is described below. Remember that safety messages by themselves do not eliminate danger and are not a substitute for proper accident prevention measures.



Indicates an imminently hazardous situation which, if not avoided, WILL result in death or serious injury.



Indicates a potentially hazardous situation which, if not avoided, COULD result in death or serious injury.



Indicates a potentially hazardous situation which, if not avoided, MAY result in minor or moderate injury. It may also be used to alert against unsafe practices.



This symbol is used to alert the user to useful information about proper operation of the equipment.

WARNING

Safety Instructions For Power Tools

1. **KEEP GUARDS IN PLACE** and in working order.
2. **REMOVE ADJUSTING KEYS AND WRENCHES.** Form habit of checking to see that keys and adjusting wrenches are removed from tool before turning on.
3. **KEEP WORK AREA CLEAN.** Cluttered areas and benches invite accidents.
4. **DON'T USE IN DANGEROUS ENVIRONMENT.** Don't use power tools in damp or wet locations, or where any flammable or noxious fumes may exist. Keep work area well lighted.
5. **KEEP CHILDREN AND VISITORS AWAY.** All children and visitors should be kept a safe distance from work area.
6. **MAKE WORK SHOP CHILD PROOF** with padlocks, master switches, or by removing starter keys.
7. **DON'T FORCE TOOL.** It will do the job better and safer at the rate for which it was designed.
8. **USE RIGHT TOOL.** Don't force tool or attachment to do a job for which it was not designed.

WARNING

Safety Instructions For Power Tools

9. **USE PROPER EXTENSION CORD.** Make sure your extension cord is in good condition. Conductor size should be in accordance with the chart below. The amperage rating should be listed on the motor or tool nameplate. An undersized cord will cause a drop in line voltage resulting in loss of power and overheating. Your extension cord must also contain a ground wire and plug pin. Always repair or replace extension cords if they become damaged.

Minimum Gauge for Extension Cords

AMP RATING	LENGTH		
	25ft	50ft	100ft
0-6	18	16	16
7-10	18	16	14
11-12	16	16	14
13-16	14	12	12
17-20	12	12	10
21-30	10	10	No

10. **WEAR PROPER APPAREL.** Do not wear loose clothing, gloves, neckties, rings, bracelets, or other jewelry which may get caught in moving parts. Non-slip footwear is recommended. Wear protective hair covering to contain long hair.
11. **ALWAYS USE SAFETY GLASSES.** Also use face or dust mask if cutting operation is dusty. Everyday eyeglasses only have impact resistant lenses, they are NOT safety glasses.
12. **SECURE WORK.** Use clamps or a vise to hold work when practical. It's safer than using your hand and frees both hands to operate tool.
13. **DON'T OVERREACH.** Keep proper footing and balance at all times.
14. **MAINTAIN TOOLS WITH CARE.** Keep tools sharp and clean for best and safest performance. Follow instructions for lubricating and changing accessories.
15. **DISCONNECT TOOLS** before servicing and changing accessories, such as blades, bits, cutters, and the like.
16. **REDUCE THE RISK OF UNINTENTIONAL STARTING.** Make sure switch is in off position before plugging in.
17. **USE RECOMMENDED ACCESSORIES.** Consult the owner's manual for recommended accessories. The use of improper accessories may cause risk of injury.
18. **CHECK DAMAGED PARTS.** Before further use of the tool, a guard or other part that is damaged should be carefully checked to determine that it will operate properly and perform its intended function. Check for alignment of moving parts, binding of moving parts, breakage of parts, mounting, and any other conditions that may affect its operation. A guard or other part that is damaged should be properly repaired or replaced.
19. **NEVER LEAVE TOOL RUNNING UNATTENDED. TURN POWER OFF.** Don't leave tool until it comes to a complete stop.

WARNING

Additional Safety Instructions For Sanders

- 1. MAINTAIN A SECURE GRIP ON THE WORKPIECE.** The belt speed is approximately 1800 FPM. If control is lost, the workpiece can be propelled from the machine at extreme speed.
- 2. CREATE A SAFETY ZONE AROUND THE SANDING SURFACE.** If you can't control your workpiece with your hands at least 6" away from the sanding belt, you should create a jig or other device to hold the workpiece safely.
- 3. REPLACE BELTS WHEN WORN OR DAMAGED.** A torn or damaged belt could be unexpectedly expelled from the machine if not replaced.
- 4. KEEP YOUR WORKPIECE SOLIDLY ON THE SANDER TABLE.** A well-secured workpiece is less likely to lose control during sanding operations.
- 5. INSPECT MATERIALS FOR DEFECTS.** Knots and splinters can shoot from the machine with great force. Make sure defective materials are not used on the belt sander. Foreign objects such as nails and staples should also be removed before sanding.
- 6. TURN OFF THE SANDER WHEN NOT IN USE.** Never leave a machine running unattended.
- 7. DO NOT** stand directly in line with sanding accessories when turning the machine on.
- 8. DO NOT** force the workpiece against the belt during operation. Firmly grasp the workpiece in both hands and ease it against the belt using light pressure.
- 9. DO NOT** wear loose clothing while operating this machine. Roll up sleeves or button sleeves at the cuff.
- 10. DO NOT** place hands near, or in contact with belt during operation.
- 11. WEAR A DUST MASK OR RESPIRATOR** when sanding, even if you have a reliable method of dust collection.
- 12. PERFORM MACHINE INSPECTIONS** and maintenance service promptly when called for.

WARNING

Operating this equipment has the potential to propel debris into the air which can cause eye injury. Always wear safety glasses or goggles when operating equipment. Everyday glasses or reading glasses only have impact resistant lenses, they are not safety glasses. Be certain the safety glasses you wear meet the appropriate standards of the American National Standards Institute (ANSI).

CAUTION

No list of safety guidelines can be complete. Every shop environment is different. Always consider safety first, as it applies to your individual working conditions. Use this and other machinery with caution and respect. Failure to do so could result in serious personal injury, damage to equipment or poor work results.

SECTION 2: CIRCUIT REQUIREMENTS

220V/110V Operation

The Model G1140 has a dual-voltage 1½ HP, 1720 RPM motor which has been pre-wired for use in a 220V single phase circuit. The cord set enclosed does not have a plug as the style of plug you require will depend upon the type of service you currently have or plan to install. If you will be installing a new receptacle and plug, we recommend either of the styles shown in **Figure 1**. Note that you have the choice between simple plug-in and twist-lock plug styles.

Should you prefer to utilize the 110V capability, a wiring diagram is provided near the back of this manual showing the wiring changes needed. Operating at 110V will also require installing a grounded plug.



Circuit Load

The Model G1140 will draw approximately 8 amps at 220V and 16 amps at 110V. Circuit protection when operating at 220V should be on a breaker rated at 15 amps or a fuse rated at 20 amps. At 110V a 20 amp slow-blow fuse or breaker should be used. Fusing at amperage ratings higher than these will not adequately protect the motor from high heat caused by overloading. You are cautioned that equipment returned to us for service that shows evidence of being over-fused will be repaired or replaced totally at the customer's expense, regardless of the present warranty status.

Be aware that other machines operating on the same circuit simultaneously will also add load which can cause the circuit protection system to trip.

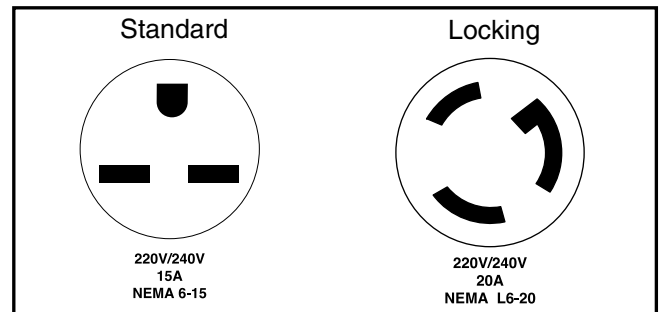

Figure 1. Two typical outlet/plug configurations.

Grounding

In the event of a malfunction or breakdown, grounding provides a path of least resistance for electric current to reduce the risk of electric shock. This tool is equipped with an electric cord having an equipment-grounding conductor which must be properly connected to a grounding plug. The plug must be inserted into a matching outlet that is properly installed and grounded in accordance with all local codes and ordinances.

Improper connections of the electrical-grounding conductor can result in risk of electric shock. The conductor with green or green and yellow striped insulation is the electrical-grounding conductor. If repair or replacement of the electric cord or plug is necessary, do not connect the equipment grounding conductor to a live terminal.

WARNING

This equipment must be grounded. Verify that any existing electrical outlet and circuit you intend to plug into is actually grounded. If it is not, it will be necessary to run a separate 12 A.W.G. copper grounding wire from the outlet to a known ground. Under no circumstances should the grounding pin from any three-pronged plug be removed. **Serious injury may occur.**



Extension Cords

We do not recommend the use of extension cords on 220V equipment. It is much better to arrange the placement of your equipment and the installed wiring to eliminate the need for extension cords. Should it be necessary to use an extension make sure the cord is rated Hard Service (grade S) or better. Refer to the chart in Section 1: Safety Instructions to determine the minimum gauge for the extension cord. The extension cord must also contain a ground wire and plug pin. Always repair or replace extension cords when they become worn or damaged.



Wiring Diagram

Your G1140 machine comes pre-wired for 220 volt operation. A wiring diagram is provided at the back of this manual should it be necessary to repair or revise the wiring. Always utilize a qualified electrician when doing any electrical work on this equipment.



CAUTION

We have covered some basic electrical requirements for the safe operation of your Edge Sander. These requirements are not necessarily comprehensive. You must be sure that your particular electrical configuration complies with local and state codes. Ensure compliance by checking with your local municipality or a licensed electrician.

SECTION 3: GENERAL INFORMATION

Commentary

We are proud to offer the Grizzly Model G1140 Edge Sander. The Model G1140 is part of a growing Grizzly family of fine woodworking machinery. When used according to the guidelines set forth in this manual, you can expect years of trouble-free, enjoyable operation and proof of Grizzly's commitment to customer satisfaction.

The Model G1140 is intended for home and medium-duty professional use. This sander features a 1,720 RPM, 1½ HP capacitor-start motor, mechanical ON/OFF switch, 4" dust port and a cast iron working table. All running parts utilize shielded ball bearings, which require no lubrication for the life of the bearings.

We are also pleased to provide this manual with the Model G1140. It was written to guide you through assembly, review safety considerations, and cover general operating procedures. It represents our effort to produce the best documentation possible. If you have any comments regarding this manual, please write to us at the address below:

Grizzly Industrial, Inc.
% Technical Documentation
P.O. Box 2069
Bellingham, WA 98227-2069

Most importantly, we stand behind our machines. If you have any service questions or parts requests, please call or write us at the location listed below.

Grizzly Industrial, Inc.
1203 Lycoming Mall Circle
Muncy, PA 17756

Phone: (570) 546-9663

Fax: (800) 438-5901

E-Mail: techsupport@grizzly.com

Web Site: <http://www.grizzly.com>

The specifications, drawings, and photographs illustrated in this manual represent the Model G1140 as supplied when the manual was prepared. However, owing to Grizzly's policy of continuous improvement, changes may be made at any time with no obligation on the part of Grizzly. Whenever possible, though, we send manual updates to all owners of a particular tool or machine. Should you receive one, we urge you to insert the new information with the old and keep it for reference.

CAUTION

To operate this, or any power tool, safely and efficiently, it is essential to become as familiar with its characteristics as possible. The time you invest before you begin to use your Model G1140 will be time well spent. **DO NOT** operate this machine until you are completely familiar with the contents of this manual. Make sure you read and understand all of the safety procedures. If you do not understand something, **DO NOT** operate the machine.



Unpacking

This G1140 Edge Sander is shipped from the manufacturer in a carefully packed carton. If you discover the machine is damaged after you've signed for delivery, and the truck and driver are gone, you will need to file a freight claim with the carrier. Save the containers and all packing materials for possible inspection by the carrier or its agent. Without the packing materials, filing a freight claim can be difficult. *If you need assistance determining whether you need to file a freight claim, or with the procedure to file one, please contact our Customer Service.*

WARNING

The G1140 is a very heavy machine (250 lbs. shipping weight). **DO NOT over-exert yourself while unpacking or moving your machine – get assistance. In the event that your machine must be moved up or down a flight of stairs, be sure that the stairs are capable of supporting the combined weight of people and the machine. Serious personal injury may occur.**

When you are completely satisfied with the condition of your shipment, you should inventory its parts.

NOTICE

Please keep all packaging materials until you are satisfied that the machine is in good condition. Should you need to file a freight claim, the carrier's agent will require inspection of those materials. Settling a claim can be difficult if packaging is not available.



Piece Inventory

After all the parts have been removed from the carton, you should have:

- Sanding unit
- Sanding Table
- Trunnions (2)
- Table Bracket w/ Lead Screw
- Lead Screw Bracket
- Hand Wheel
- Stabilizing Bracket
- Stabilizing Post
- Lock Handles (2)
- Plastic Knob
- Lever Handle
- Auxiliary Table w/ Post
- Dust Port
- 6" x 80" Sanding Belt
- Back Stop
- Phillips® Hd Screw 10-24 x 3/4" (4)
- Feet (4)
- Miter Body
- Hex Bolt 5/16" - 18 x 1" (2)
- Flat Washer 5/16" (2)
- Flat Washer 3/8" (2)

In the event that any non proprietary parts are missing (e.g. a nut or a washer...), we would be glad to replace them, or, for the sake of expediency, replacements can be obtained at your local hardware store.

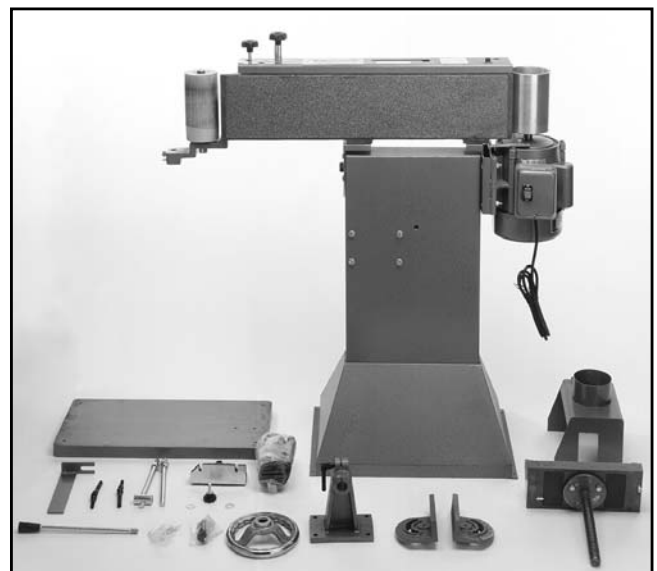

Figure 2. Overview of all the parts.



Clean Up

The unpainted surfaces are coated with a waxy oil to protect it from corrosion during shipment. Remove this protective coating with a solvent cleaner or citrus-based degreaser. Avoid chlorine-based solvents as they may damage painted surfaces should they come in contact. Always follow the usage instructions on the product you choose for clean up.

CAUTION

Many of the solvents commonly used to clean machinery can be highly flammable, and toxic when inhaled or ingested. Always work in well-ventilated areas far from potential ignition sources when dealing with solvents. Use care when disposing of waste rags and towels to be sure they do not create fire or environmental hazards. Keep children and animals safely away when cleaning and assembling this machine.

WARNING

Do not use gasoline or other petroleum-based solvents to remove this protective coating. These products generally have low flash points which makes them extremely flammable. A risk of explosion and burning exists if these products are used. Serious personal injury may occur.

CAUTION

All die-cut metal parts have a sharp edge (called “flashing”) on them after they are formed. This is generally removed at the factory. Sometimes a bit of flashing might escape inspection, and the sharp edge may cause cuts or lacerations when handled. Please examine the edges of all die-cut metal parts and file or sand the edge to remove the flashing before handling.



Site Considerations

1. **Floor Load:** Your G1140 Sander represents a large weight load in a small footprint. Most commercial floors are suitable for the Model G1140. Some residential floors may require additional build up to support both machine and operator.
2. **Working Clearances:** Consider existing and anticipated needs, size of material to be processed through each machine, and space for auxiliary stands, work tables or other machinery when establishing a home for your edge sander. Allow sufficient room to safely run your machines in any foreseeable operation.
3. **Lighting and Outlets:** Lighting should be bright enough to eliminate shadow and prevent eye strain. Electrical circuits should be dedicated or large enough to handle amperage requirements. Outlets should be located near each machine so power or extension cords are clear of high-traffic areas. Observe local electrical codes for proper installation of new lighting, outlets, or circuits.



WARNING

Be certain that this machine is properly grounded before attempting to use it. If you are unsure of the quality and condition of the circuit you intend to use, have it inspected and repaired by a qualified electrician.

NOTICE

Ensure that the Model G1140 is located on a flat, level surface. This will maximize the stability of the machine and ensure that adjustments are accurate. For conditions where permanent mounting is possible, we recommend bolting the Edge Sander to your floor. This type of mounting will minimize vibration and provide a more stable work environment.

SECTION 4: ASSEMBLY

Beginning Assembly

Assembly of the G1140 is straightforward. We have organized the assembly process into steps. Please follow them in sequence.

Tools Required: Only a few common tools are needed to assemble this machine. Specifically, a 6" adjustable wrench, 12mm open end wrench, regular and Phillips® screwdriver and an 8mm Allen® wrench.

WARNING

All die-cut metal parts have a sharp edge (called “flashing”) on them after they are formed. This is generally removed at the factory. Sometimes a bit of flashing might escape inspection, and the sharp edge can cause cuts or lacerations when handled. Please examine the edges of all die-cut metal parts and file or sand the edge to remove the flashing before handling them. Serious injury may occur.

WARNING

This machine is very heavy and can be awkward to handle without help. Get assistance during periods of assembly which require that the machine or any of its major components be moved, tilted, or carried. Failure to use proper lifting techniques could result in serious injury or damage to the machine.



Feet

1. Carefully lay the machine over on its side. Have someone assist you when doing this. Do not attempt to lay the machine over by yourself.
2. Install the four feet using the 10-24 x 3/4" Phillips® Head Screws provided. **Figure 3.** Get assistance and upright the machine.



Figure 3. Installing the feet.



Working Table

1. Bolt the lead screw bracket to the front of the stand using the four Hex Bolts already threaded in place. **See Figure 4.**



Figure 4. Lead screw bracket Installed.

2. Thread the horizontal brace into position, but do not tighten; the brace will require further adjustment later on. **See Figure 5.**



Figure 5. Installing the horizontal brace.

3. Locate the lead screw/table bracket assembly and the handwheel. Thread the handwheel onto the lead screw about halfway and insert the lead screw into the lead screw bracket. **See Figure 6.**



Figure 6. Installing the lead screw assembly.

4. Locate the vertical brace. Turn the horizontal brace approximately 45° and insert the vertical brace through the hole at the end of the horizontal brace. Rotate the horizontal / vertical brace assembly to 90°.
5. Install the hex nut and washer provided, and screw on until ½" of the threaded end is visible above the washer. Insert the threaded end of the vertical brace through the hole in the bottom of the table bracket and re-install the flat washer and hex nut back onto the shaft. **See Figure 7.**

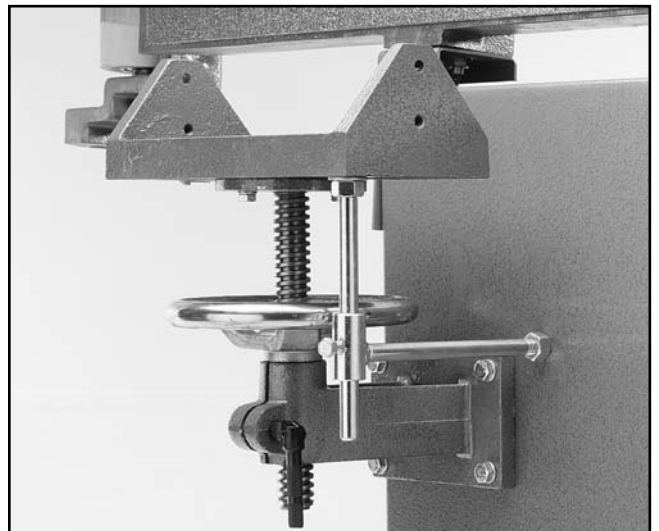

Figure 7. Horizontal / vertical brace installed.

6. Measure the table bracket to the stand to assure it is parallel to the stand. **See Figure 8.** If the bracket is not parallel, remove the vertical brace, thread the horizontal brace in or out an appropriate amount and reinstall the vertical brace.

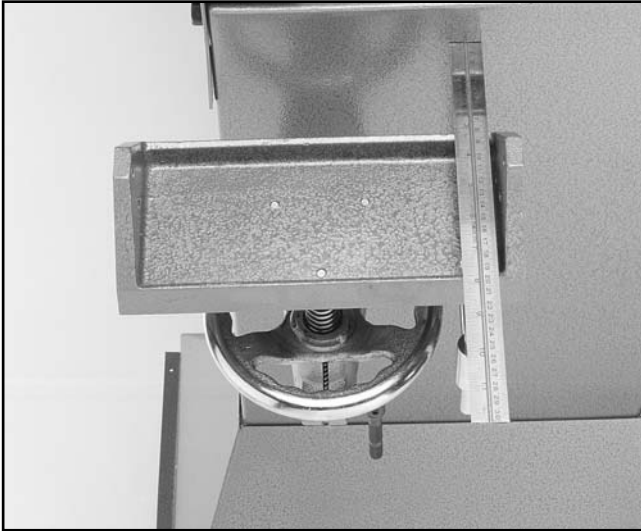

Figure 8. Checking table bracket for parallelism.

7. Once the table bracket has been properly adjusted, tighten the horizontal brace jam nut and the two hex nuts that hold the vertical brace in place.
8. Attach the table trunnions to the table bracket. Each is held in place with a $\frac{3}{8}$ " flat washer and lock handle. **See Figure 9.** The trunnion with the scale attaches to the left side.



Figure 9. Table trunnions installed.

9. Leaving the table trunnion lock handles slightly loose, bolt the working table to the trunnions using the two (2) $\frac{5}{16}$ "-18 x $\frac{3}{4}$ " hex bolts and $\frac{5}{16}$ " flat washers supplied. **See Figure 10.** Adjust the table so it is approximately $\frac{1}{8}$ " to $\frac{3}{16}$ " from the edge of the sanding platen and tighten down the mounting bolts.



Figure 10. Attaching the working table.

10. Adjust the work table 90° to the sanding platen by checking it with a square. Adjust as necessary and tighten the table lock handles. At this time adjust the pointer to 90° . **See Figure 11.**

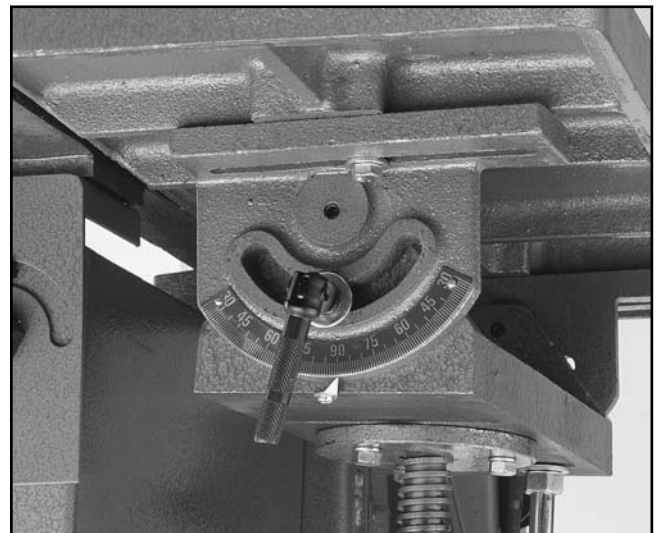

Figure 11. Setting the pointer to 90° .



Miter Body

Set the miter body onto its pivot hole and secure into place with the plastic lock knob provided. **See Figure 12.** The miter body should only be used when sanding the ends of workpieces at least 8" long. Do not use it as a back stop.

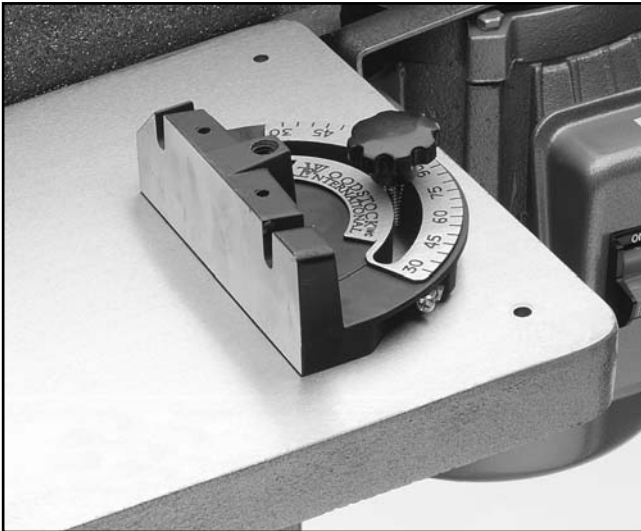

Figure 12. Attaching the miter body.



⚠️ WARNING

Be certain that this machine is properly grounded before attempting to use it. If you are unsure of the quality and condition of the circuit you intend to use, have it inspected and repaired by a qualified electrician. Failure to ensure proper grounding could result in fatal or serious injury and/or equipment damage.

⚠️ CAUTION

Make your workshop child-safe. Ensure that idle machines have their safety keys removed, sharp blades are stored safely out of reach, and that your shop is securely locked when your shop is not in use.

Quick Release Lever

1. Loosen the belt tracking lock knob located at the top left of the machine.
2. Slide the quick release lever through the slot on the top of the platen cover. Thread it into place until it bottoms out. **See Figure 13.** It may be necessary to have an assistant push the idler roller back into the machine to allow the quick release lever to line up with the thread in the yoke.

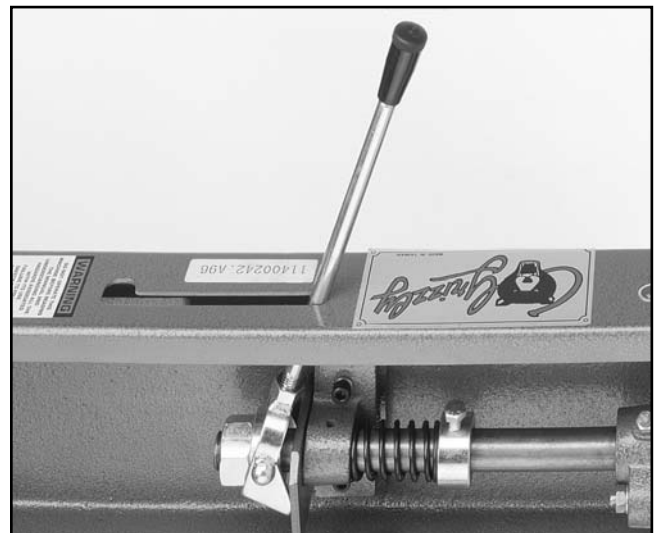

Figure 13. Installing the quick release lever.

⚠️ WARNING

Operating this equipment has the potential to propel debris into the air which can cause eye injury. Always wear safety glasses or goggles when operating equipment. Everyday glasses or reading glasses only have impact resistant lenses, they are not safety glasses. Be certain the safety glasses you wear meet the appropriate standards of the American National Standards Institute (ANSI).



Auxiliary Table

Slide the auxiliary table into place as pictured in **Figure 14**. Tighten the two thumb screws when table is at desired working height. It is not necessary to have the auxiliary table mounted at all times and can be installed only when needed.

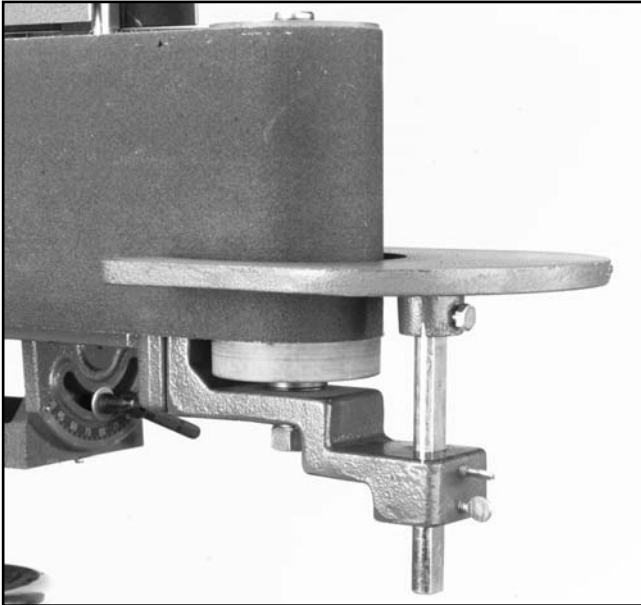

Figure 14. Installing the auxiliary table.



Dust Hood

Bolt the dust hood on using the hex bolts already threaded in place. **See Figure 15.**

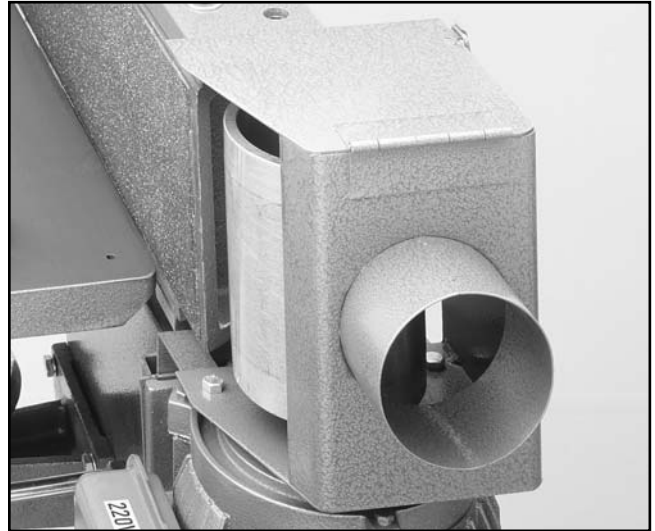

Figure 15. Dust hood mounted in place.

!WARNING

Operating this equipment has the potential for respiratory damage to occur due to the level of airborne dust it produces. Always use a dust collection system AND wear a dust mask or respirator to avoid breathing wood dust. Serious personal injury may occur.



Back Stop

Attach the back stop as shown in **Figure 16**. Set the back stop no more than $\frac{1}{8}$ " from the sandpaper. This will prevent objects from being jammed between the back stop and the platen causing a potentially dangerous situation.



Figure 16. Back stop properly installed.

WARNING

DO NOT attempt to operate this machine without this back stop in place and properly adjusted as described above. An improper gap between the stop and the belt can create a situation where a finger or hand can get trapped against the moving belt. Serious injury could occur.



Belt Installation

1. Loosen the belt tracking lock knob on the top left of the machine. Open the lid of the dust port and move the quick release lever to its locked open position. **See Figure 17.**

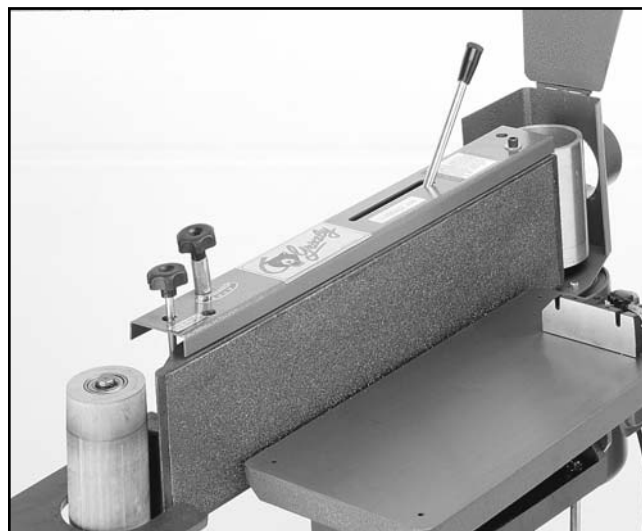

Figure 17. Sander ready for belt installation.

2. Check the back side of the belt for an arrow indicating direction of rotation. The sanding belt rotates counter-clockwise.
3. Slide the belt over the rollers. Move the quick release lever back to its tensioned position. **See Figure 18.** Belt tracking is covered in the next section.

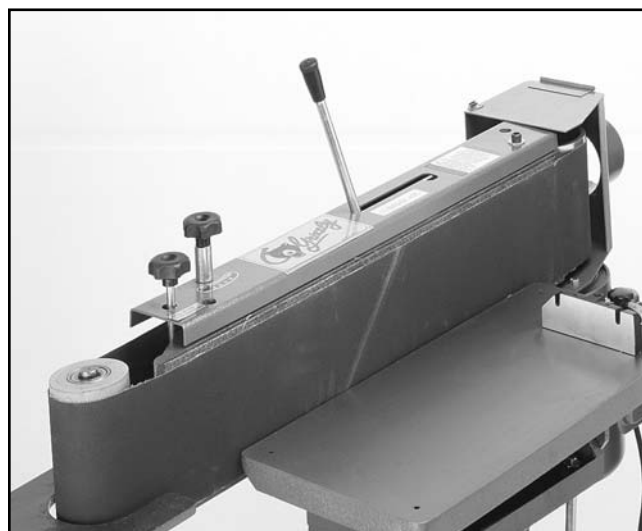

Figure 18. Belt installed.



SECTION 5: ADJUSTMENTS

Belt Tracking

1. Carefully move the belt left to right by hand and adjust the tracking knob as necessary to achieve proper tracking. **See Figure 19.**
2. Before beginning this step, read the entitled **Test Run** on page 18. Connect to power and turn the machine on and off quickly. If the belt appears to track OK turn the machine on and fine tune the tracking. Tighten the tracking lock knob.

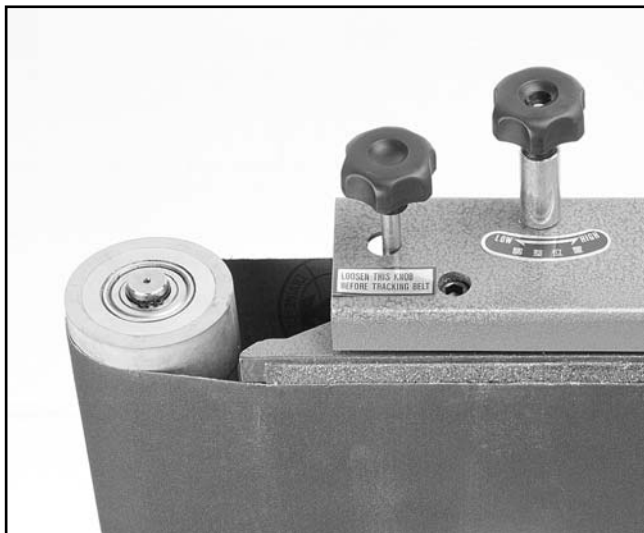

Figure 19. Location of tracking knob.

CAUTION

Moving sanding belts are dangerously abrasive. Use extreme caution when working near sanding surfaces. Use extreme caution while making adjustments that require momentary or extended operation of the edge sander. Failure to exercise care while sanding could result in severe injury.



Auxiliary Table

Loosen the thumb screws, position the auxiliary table, re-tighten the thumb screws. **See Figure 20.** Note that the ends of the roller are tapered. This helps keep the belt tracked. When using the end roller for curved sanding, we recommend you use the center portion of the roller to assure proper belt tracking. This also prevents the edge of the workpiece from becoming tapered.

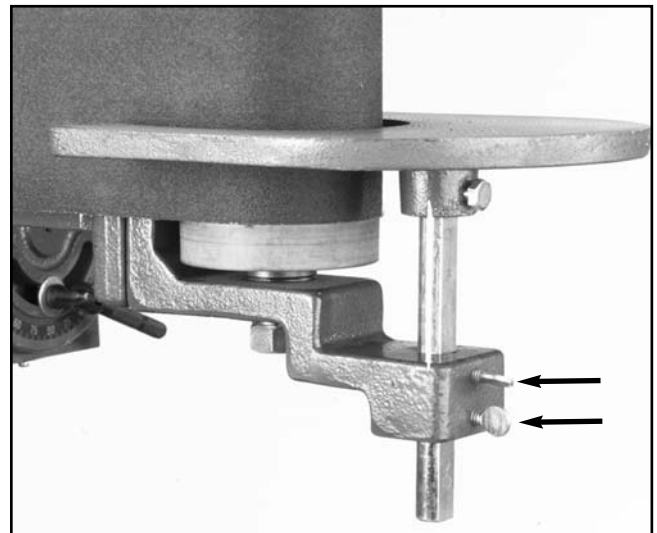

Figure 20. Table adjustment thumbscrews.



Table Tilt

1. Loosen the lock handles, tilt the working table to the desired angle and retighten the lock handles. **See Figure 21.**
2. It may be necessary to re-adjust the working table closer to the platen. Not more than a 1/4" gap should exist between the platen and the working table.

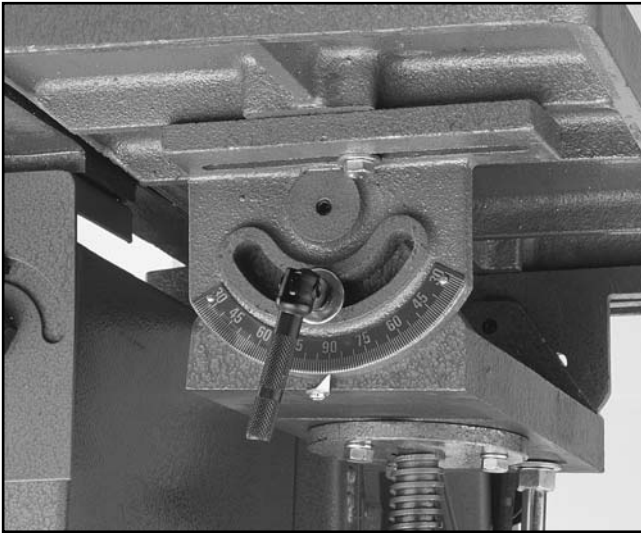

Figure 21. Table tilt adjustment.



Table Height

1. Loosen lead screw lock handle and stabilizing shaft lock bolt. **See Figure 22.**
2. Turn hand wheel and position working table to desired height.
3. Retighten lock handle and lock bolt.

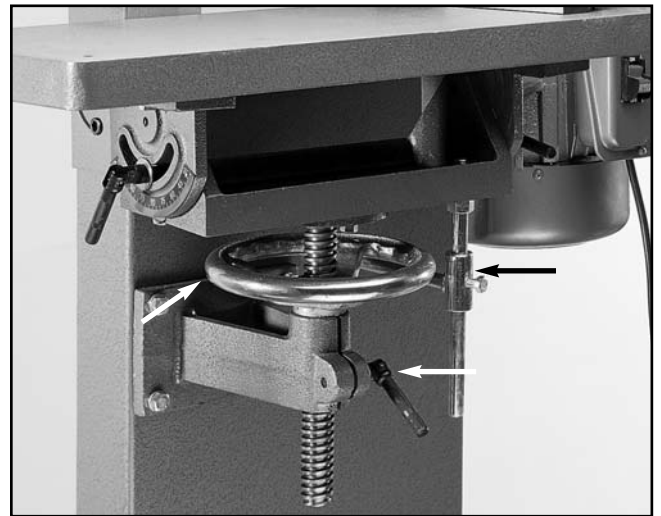

Figure 22. Table height adjustment.



Platen Tilt

1. Loosen the lock bolt shown in **Figure 23**.
2. Carefully tilt the platen assembly over. **Figure 24**.
3. After returning the platen assembly back to its upright position, retighten the lock bolt depicted in **Figure 23**.

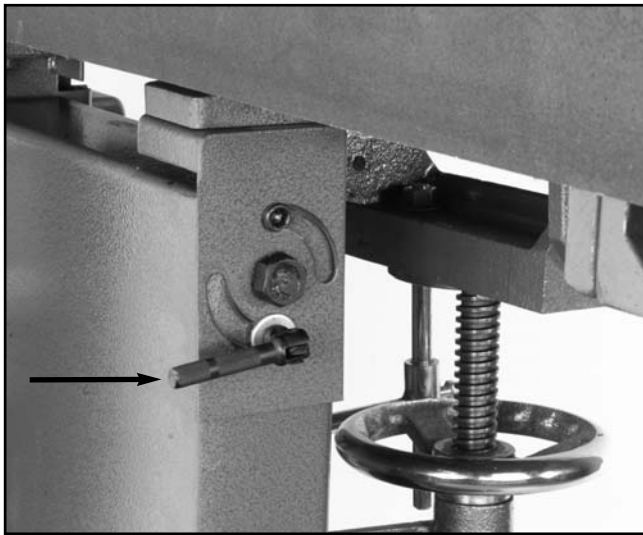

Figure 23. Platen lock bolt.

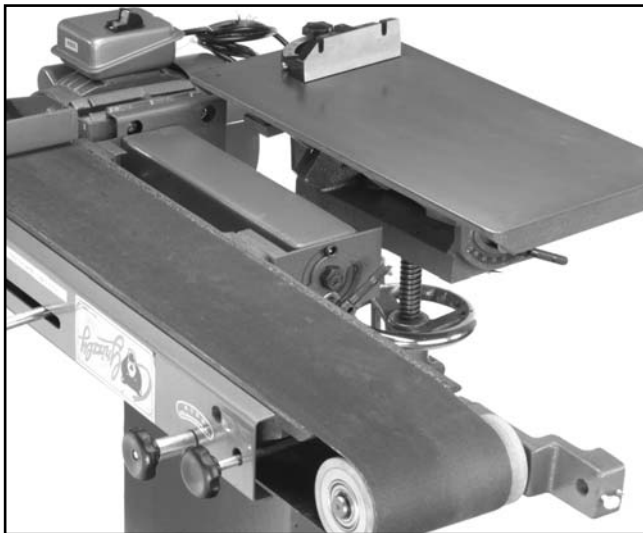

Figure 24. Platen tilted over 90°.



Belt Tension

Belt tension is preset at the factory and usually requires no adjustment. If the need to increase the tension should occur, unthread the retaining nut at the end of the idler roller mounting shaft. **See Figure 25.** Do not unthread the nut more than $\frac{1}{2}$ its length. If tension problems persist, call the service center for further help.

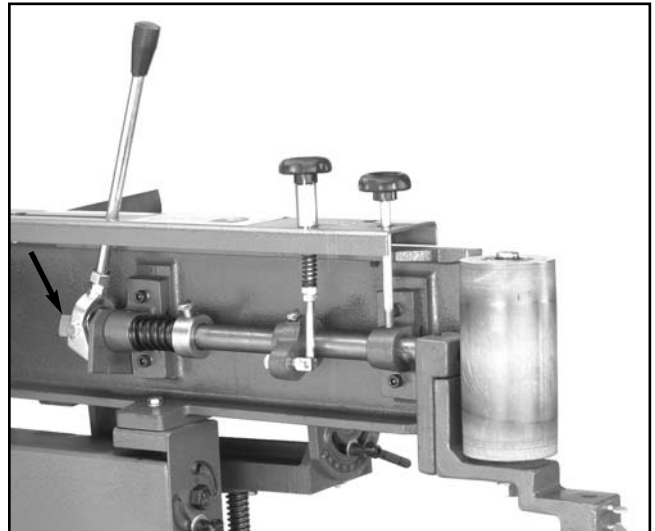

Figure 25. Belt tension mechanism.



⚠️ WARNING

Operating this equipment has the potential to propel debris into the air which can cause eye injury. Always wear safety glasses or goggles when operating equipment. Everyday glasses or reading glasses only have impact resistant lenses, they are not safety glasses. Be certain the safety glasses you wear meet the appropriate standards of the American National Standards Institute (ANSI).

SECTION 6: OPERATIONS

Test Run

Once the assembly is complete and the adjustments are done to your satisfaction, you are ready to test the machine.

Turn on the power supply at the main panel. Press the START button. Make sure that your finger is poised on the STOP button, just in case there's a problem. The edge sander should run smoothly, with little or no vibration or rubbing noises. Strange or unnatural noises should be investigated and corrected before operating the machine further.

If noises occur that can not be found by visual inspection, feel free to contact our service department for help.

If the sander runs smoothly, try sanding a piece of lumber. If a problem exists, stop the machine and review all the adjustments. Call for assistance, if needed.



CAUTION

Use extreme caution when preparing for your initial test run. Always keep one finger on the STOP button in order to quickly shut off the machine in the event of a malfunction.

DO NOT attempt to investigate or adjust the machine while the machine is still running. Turn off the machine and disconnect it from its power source before attempting any repair or adjustment. Serious operator injury could occur if this guideline is not followed.

Edge & End Sanding

Figure 26 depicts a typical edge sanding process. The back stop can be used for shorter workpieces if so desired.

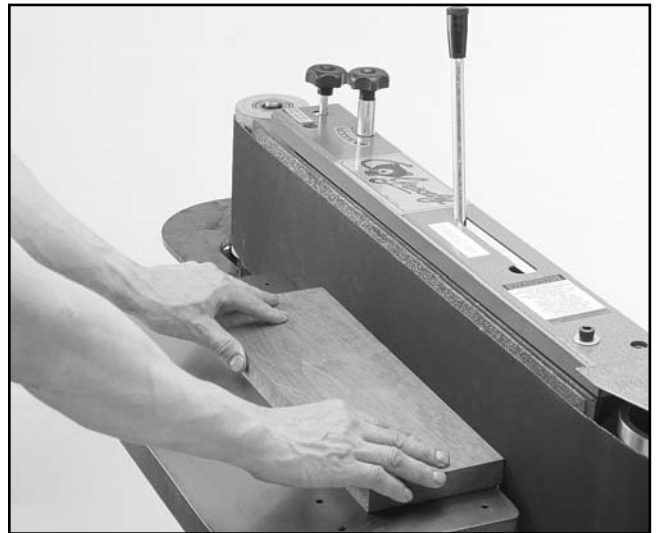

Figure 26. Typical edge sanding method.

Figure 27 depicts a typical method for sanding the end of a workpiece.

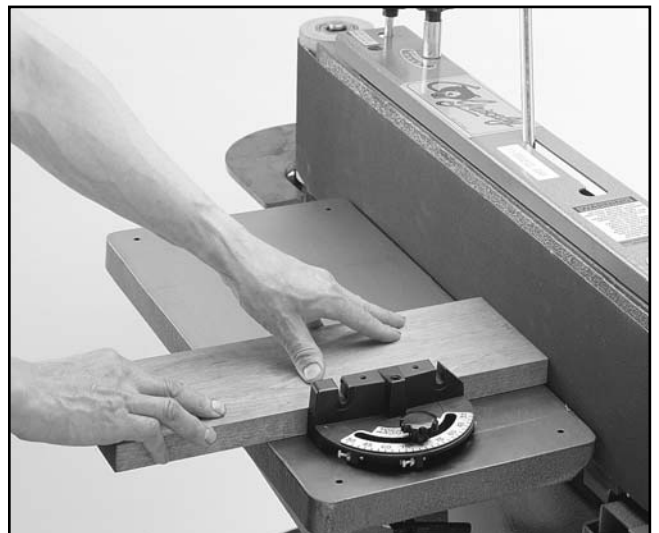

Figure 27. Typical end grain sanding method.



Horizontal Sanding

When face sanding, tilt the platen so it is horizontal and use the back stop to hold your workpiece. Apply even hand pressure while moving the workpiece back and forth for even belt wear.



Figure 28. Typical face sanding method.



!WARNING

Sanding surfaces are capable of causing serious personal injury if they come in contact with fingers, hands or other body parts. Use extreme care to provide a large buffer area between the sanding belt and any part of your body.

Contour Sanding

When contour sanding, adjust the auxiliary table up or down so the workpiece is roughly centered on the roller. Move the workpiece over the roller to achieve your desired profile.

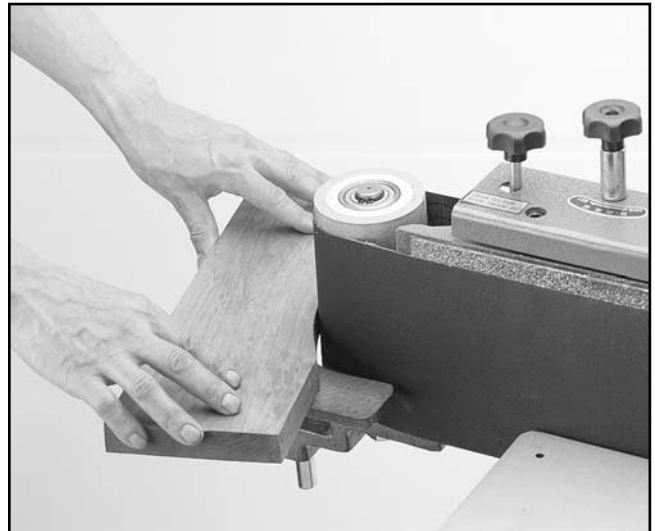

Figure 29. Typical contour sanding method.



!CAUTION

Do not operate this equipment when wearing loose clothing, gloves, neckties, rings, bracelets or other jewelry which might get caught in the moving belt or trapped between the belt and the tables. Serious personal injury may result.

SECTION 7: MAINTENANCE

General

Make a habit of inspecting your sander each time you use it. Check for the following conditions and repair or replace when necessary.

1. Loose mounting bolts.
2. Worn switch.
3. Worn or damaged cords and plugs.
4. Damaged sanding belt.
5. Any other condition that could hamper the safe operation of this machine.



Lubrication

Shielded and pre-lubricated ball bearings require no lubrication for the life of the bearings. In a continuous-use environment, expect the bearings to last for several years. With intermittent use, bearings can be expected to last much longer. All bearings are standard sizes and can be easily replaced.



Table

The table and other non-painted surfaces on the Model G1140 should be protected against rust and pitting. Wiping the sander clean after every use ensures that moisture from sander dust isn't allowed to trap moisture against bare metal surfaces.

Some woodworkers recommend using automotive paste wax on exposed steel and cast iron surfaces. The wax provides a layer of protection, as well as reducing friction between lumber and the table, making cuts faster and smoother. Avoid waxes that contain silicone or other synthetic ingredients. These materials can find their way into lumber that's being worked, and can make staining and finishing difficult. If you use paste wax, make sure that it's 100% Carnauba wax.



SECTION 8: CLOSURE

The following pages contain general machine data, parts diagrams/lists, troubleshooting guide and Warranty/Return information for your Model G1140 Edge Sander.

If you need parts or help in assembling your machine, or if you need operational information, we encourage you to call our Service Department. Our trained service technicians will be glad to help you.

If you have comments dealing specifically with this manual, please write to our Bellingham, Washington location using the address in Section 3: General Information. The specifications, drawings, and photographs illustrated in this manual represent the Model G1140 as supplied when the manual was prepared. However, due to Grizzly's policy of continuous improvement, changes may be made at any time with no obligation on the part of Grizzly. Whenever possible, though, we send manual updates to all owners of a particular tool or machine. Should you receive one, add the new information to this manual and keep it for reference.

We have included some important safety measures that are essential to this machine's operation. While most safety measures are generally universal, Grizzly reminds you that each workshop is different and safety rules should be considered *as they apply to your specific situation*.

WARNING

Operating this equipment has the potential to propel debris into the air which can cause eye injury. Always wear safety glasses or goggles when operating equipment. Everyday glasses or reading glasses only have impact resistant lenses, they are not safety glasses. Be certain the safety glasses you wear meet the appropriate standards of the American National Standards Institute (ANSI).

We recommend you keep a copy of our current catalog for complete information regarding Grizzly's warranty and return policy. If you need additional technical information relating to this machine, or if you need general assistance or replacement parts, please contact the Service Department listed in Section 3: Introduction.

Additional information sources are necessary to realize the full potential of this machine. Trade journals, woodworking magazines, and your local library are good places to start.

WARNING

The Model G1140 was specifically designed for sanding. **DO NOT MODIFY AND/OR USE THIS MACHINE FOR ANY OTHER PURPOSE. Modifications or improper use of this tool will void the warranty.** If you are confused about any aspect of this machine, **DO NOT** use it until you have answered all your questions. **Serious personal injury may occur.**

WARNING

Like all power tools, there is danger associated with the Model G1140 Edge Sander. Accidents are frequently caused by lack of familiarity or failure to pay attention. Use this tool with respect and caution to lessen the possibility of operator injury. If normal safety precautions are overlooked or ignored, serious personal injury may occur.





MACHINE DATA SHEET

Customer Service #: (570) 326-3806 • To Order Call: (800) 523-4777 • Fax #: (800) 438-5901

GRIZZLY MODEL G1140 HEAVY DUTY EDGE SANDER

Design Type Tilting Head Edge Sander, Floor Model

Overall Dimensions and Specifications:

Table Size22" x 10½"
 Height (With Handle Up)49"
 Length47"
 Width20"
 Idler Roller Table Dimensions4¼" x 8"
 Belt Size6" x 80"
 Belt Speed1800 FPM
 Belt Table Tilt60° - 0° - 60°
 Shipping Weight250 lbs.
 Box Size.....45" W x 47" L x 17" H
 Footprint15" x 21½"
 Platen Size6¾" x 29¾"

Construction:

BaseSteel
 TableGround Cast Iron
 Rubber Idler RollerBall Bearing

Motor:

TypeTEFC Capacitor Start Induction
 Horsepower1½ HP
 Phase / Voltage Single Phase / 110V / 120V
 Prewired220V
 Amps16 / 8
 Cycle and RPM60 Hertz / 1720 RPM
 SwitchToggle Safety Switch
 Power TransferDirect Drive
 BearingsShielded & Permanently Lubricated Ball

Features:

.....Sanding Surface Tilts Vertical to Horizontal
Miter Block
4" Dust Port
Quick Belt Release
Graphite Coated Platen

Specifications, while deemed accurate, are not guaranteed.

REVISED 4/99

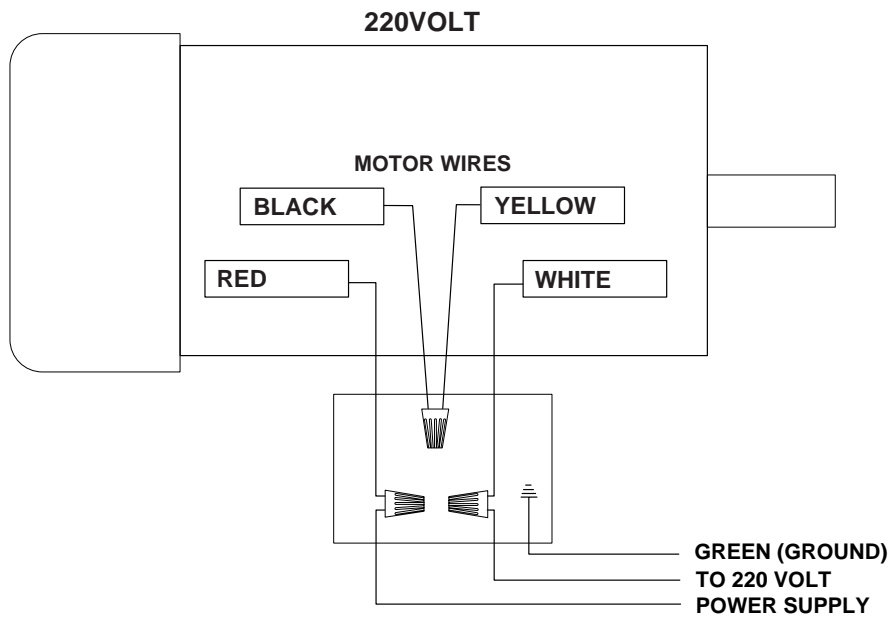
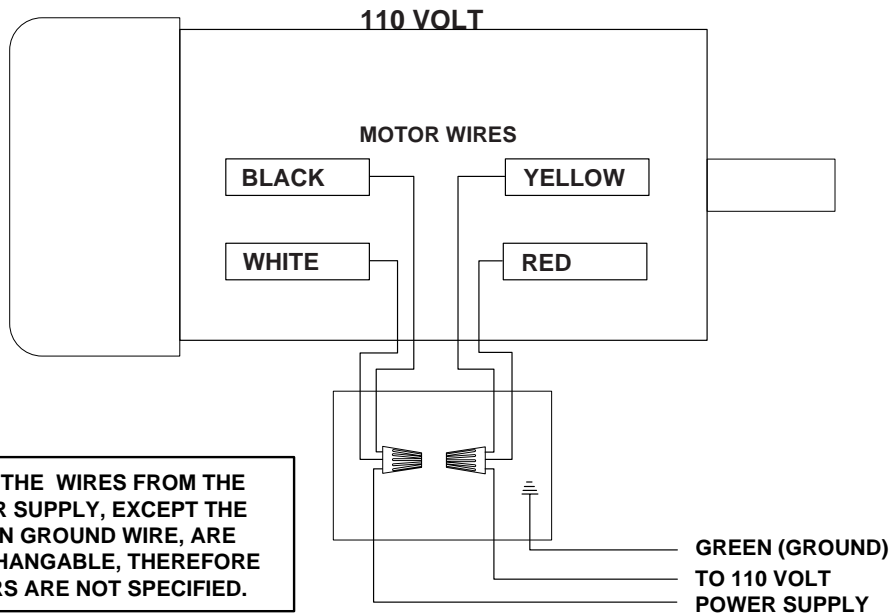

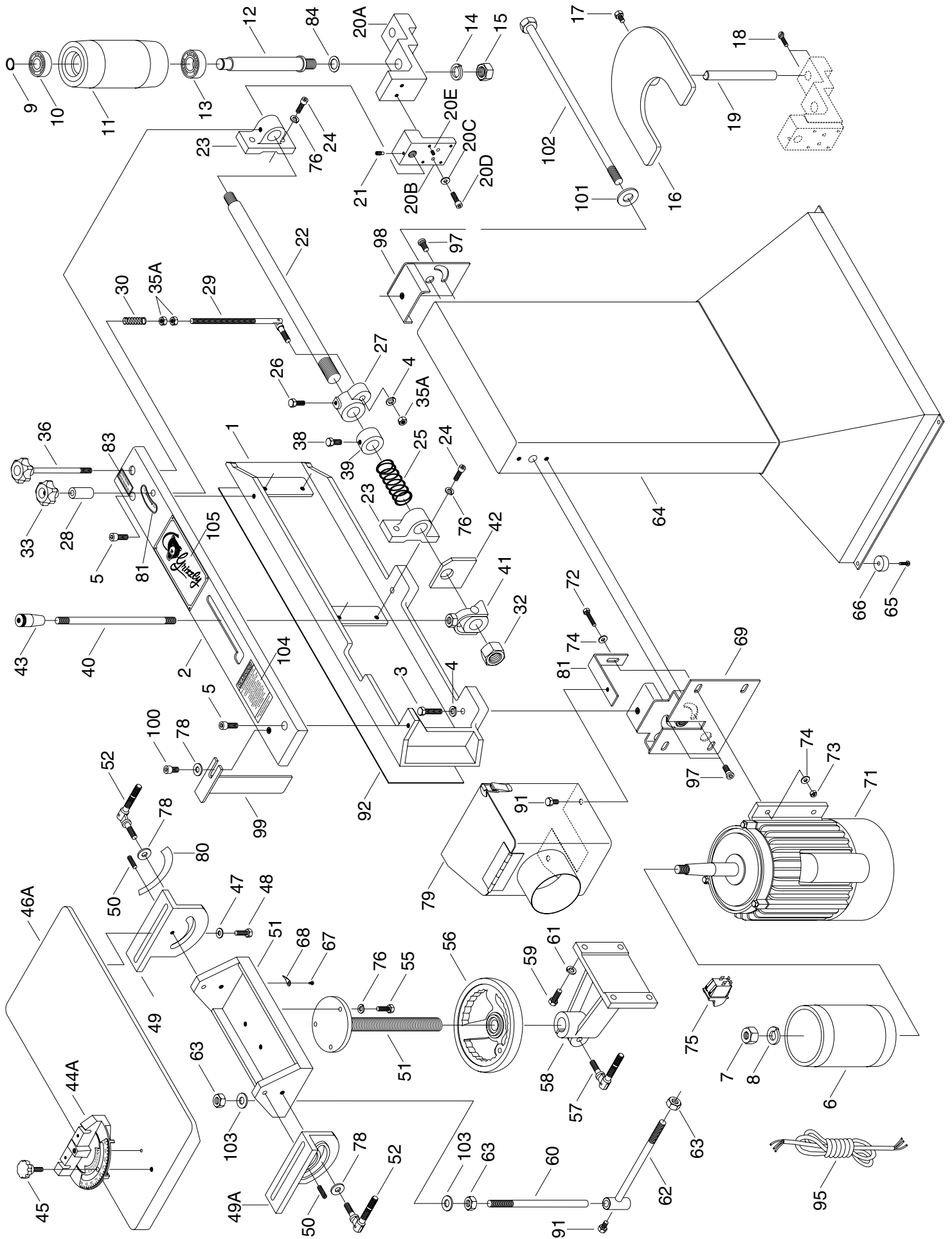

REF	PART #	DESCRIPTION
1	P1531001	PLATEN
2	P1140002	PLATEN COVER
3	PB24	HEX BOLT 3/8"-16 x 1 1/4"
4	PLW04	LOCK WASHER 3/8"
5	PSB14	CAP SCREW 3/8"-16 x 1"
6	P1531006	DRIVER ROLLER
7	PN09	HEX NUT 5/8"-18
8	PLW06	LOCK WASHER 5/8"
9	PR02	EXT RETAINING RING 20mm
10	P6204	BEARING 6204
11	P1531011	RUBBER IDLER ROLLER
12	P1531012	ROLLER AXLE
13	P6205	BEARING 6205
14	PLW06	LOCK WASHER 5/8"
15	PN04	HEX NUT 5/8"-11
16	P1531016	AUXILIARY TABLE
17	PB03	HEX BOLT 5/16"-18 x 1"
18	P1140018	THUMB SCREW
19	P1531019	AUXILIARY TABLE POST
20A	P1531020A	ROLLER SUPPORT BRACKET
20B	P1531020B	ROLLER BLOCK BRACKET
20C	PW02	FLAT WASHER 3/8"
20D	PSB26	CAP SCREW 3/8"-16 x 1 1/2"
20E	PSS03	SETSCREW 1/4"-20 x 3/8"
21	P1531021	SPECIAL SCREW
22	P1531022	BELT ADJUST SHAFT
23	P1531023	ADJUST SHAFT SLIDE
24	PSB03	CAP SCREW 5/16"-18 x 1"
25	P1531025	SPRING
26	PB03	HEX BOLT 5/16"-18 x 1"
27	P1531027	ARM CONTROL CASTING
28	P1531028	SLEEVE
29	P1531029	CONTROL SHAFT
30	P1531030	SPRING
32	PN22	HEX NUT 1" x 8
33	P1531033	TILT KNOB
35A	PN08	HEX NUT 3/8"-16
36	P1531036	LOCK KNOB
38	PB21	HEX BOLT 3/8"-16 x 3/4"
39	P1531039	COLLAR
40	P1531040	LEVER
41	P1531041	SWIVEL ASSEMBLY
42	P1531042	PLATE
43	P1531043	KNOB
44A	P1023201	MITER GAUGE BODY
45	P1019Z016	KNOB

REF	PART #	DESCRIPTION
46A	P1531046A	TABLE
47	PW07	FLAT WASHER 5/16"
48	PB03	HEX BOLT 5/16"-18 x 1"
49	P1531049	TRUNNION, LEFT
49A	P1531049A	TRUNNION, RIGHT
50	PSS01	SET SCREW 5/16"-18 x 1"
51	P1531051	TABLE SUPPORT BRACKET
52	P1531052	LEVER SCREW
55	PB07	HEX BOLT 5/16"-18 x 3/4"
56	P1531056	HAND WHEEL
57	P1531057	LEVER SCREW
58	P1531058	SPLIT CASTING
59	PB18	HEX BOLT 3/8"-16 x 1"
60	P1531060	TABLE ADJ SHAFT
61	PLW04	LOCK WASHER 3/8"
62	P1531062	LEVELING ARM SHAFT
63	PN13	HEX NUT 1/2"-13
64	P1140064	STAND
65	PS08	PHILLIPS® SCRW 10-24 x 3/4"
66	P1531066	FEET
67	PS23	PHILLIPS® HD SCR 8-32 x 1/4"
68	P1531068	POINTER
69	P1140069	MOTOR BRACKET
71	P1531071	MOTOR
72	PB12	HEX BOLT 5/16"-18 x 1 1/4"
73	PN02	HEX NUT 5/16"-18
74	PW07	FLAT WASHER 5/16"
75	PSW06	SWITCH
76	PLW01	LOCK WASHER 5/16"
78	PW02	FLAT WASHER 3/8"
79	P1531079	DUST COLLECTION HOOD
80	P1531081	LEFT BRACKET
81	P1531082	TRACKING SCALE
82	P1531049B	ANGLE SCALE
83	P1531083	LABEL
84	P1531084	SPECIAL WASHER
91	PB09	HEX BOLT 5/16"-18 x 1/2"
92	P1531080	GRAPHITE PAD
95	PWCRD220L	POWER CORD
97	P1140097	SPECIAL SCREW
98	P1140098	BRACKET
99	P1140099	BACK STOP
100	PSB14	CAP SCREW 3/8"-16 x 1"
101	P1140101	SPECIAL WASHER
102	P1140102	LOCK BOLT
103	PW01	FLAT WASHER 1/2"
104	P1140104	WARNING LABEL
105	PLABEL7	GRIZZLY LOGO LABEL

WARRANTY AND RETURNS

Grizzly Industrial, Inc. warrants every product it sells for a period of **1 year** to the original purchaser from the date of purchase. This warranty does not apply to defects due directly or indirectly to misuse, abuse, negligence, accidents, repairs or alterations or lack of maintenance. This is Grizzly's sole written warranty and any and all warranties that may be implied by law, including any merchantability or fitness, for any particular purpose, are hereby limited to the duration of this written warranty. We do not warrant or represent that the merchandise complies with the provisions of any law or acts unless the manufacturer so warrants. In no event shall Grizzly's liability under this warranty exceed the purchase price paid for the product and any legal actions brought against Grizzly shall be tried in the State of Washington, County of Whatcom.

We shall in no event be liable for death, injuries to persons or property or for incidental, contingent, special, or consequential damages arising from the use of our products.

To take advantage of this warranty, contact us by mail or phone and give us all the details. We will then issue you a "Return Number", which must be clearly posted on the outside as well as the inside of the carton. We will not accept any item back without this number. Proof of purchase must accompany the merchandise.

The manufacturers reserve the right to change specifications at any time because they constantly strive to achieve better quality equipment. We make every effort to ensure that our products meet high quality and durability standards and we hope you never need to use this warranty.

Please feel free to write or call us if you have any questions about the machine or the manual.

Thank you again for your business and continued support. We hope to serve you again soon.

WARRANTY CARD

Name _____
Street _____
City _____ State _____ Zip _____
Phone Number _____ E-Mail _____ FAX _____
MODEL # _____ Order # _____

The following information is given on a voluntary basis. It will be used for marketing purposes to help us develop better products and services. Of course, all information is strictly confidential.

- How did you learn about us?
 Advertisement Friend
 Catalog Card Deck
 World Wide Web
 Other _____
- Which of the following magazines do you subscribe to.
 American Woodworker Practical Homeowner
 Cabinetmaker Shop Notes
 Family Handyman Today's Homeowner
 Fine Homebuilding WOOD
 Fine Woodworking Wooden Boat
 Home Handyman Woodshop News
 Journal of Light Construction Woodsmith
 Old House Journal Woodwork
 Popular Mechanics Woodworker
 Popular Science Woodworker's Journal
 Popular Woodworking Workbench
 Other _____
- Which of the following woodworking/remodeling shows do you watch?
 Backyard America The New Yankee Workshop
 Home Time This Old House
 The American Woodworker Woodwright's Shop
 Other _____
- What is your annual household income?
 \$20,000-\$29,999 \$60,000-\$69,999
 \$30,000-\$39,999 \$70,000-\$79,999
 \$40,000-\$49,999 \$80,000-\$89,999
 \$50,000-\$59,999 \$90,000 +
- What is your age group?
 20-29 50-59
 30-39 60-69
 40-49 70 +
- How long have you been a woodworker?
 0 - 2 Years 8 - 20 Years
 2 - 8 Years 20+ Years
- How would you rank your woodworking skills?
 Simple Advanced
 Intermediate Master Craftsman
- What stationary woodworking tools do you own? Check all that apply.
 Air Compressor Panel Saw
 Band Saw Planer
 Drill Press Power Feeder
 Drum Sander Radial Arm Saw
 Dust Collector Shaper
 Horizontal Boring Machine Spindle Sander
 Jointer Table Saw
 Lathe Vacuum Veneer Press
 Mortiser Wide Belt Sander
 Other _____
- How many of your woodworking machines are Grizzly? _____
- Which benchtop tools do you own? Check all that apply.
 1" x 42" Belt Sander 6" - 8" Grinder
 5" - 8" Drill Press Mini Lathe
 8" Table Saw 10" - 12" Thickness Planer
 8" - 10" Bandsaw Scroll Saw
 Disc/Belt Sander Spindle/Belt Sander
 Mini Jointer
 Other _____
- How many of the machines checked above are Grizzly? _____
- Which portable/hand held power tools do you own? Check all that apply.
 Belt Sander Orbital Sander
 Biscuit Joiner Palm Sander
 Circular Saw Portable Planer
 Detail Sander Saber Saw
 Drill/Driver Reciprocating Saw
 Miter Saw Router
 Other _____
- What machines/supplies would you like Grizzly Industrial to carry?
 12" Table Saw Radial Arm Saw
 12" Jointer Panel Saw
 Combination Planer/Jointer Brass Hardware
 Paint & Finishing Supplies Lumber
 Contractor's Supplies
 Other _____
- What new accessories would you like Grizzly Industrial to carry?
 Builders Hardware Hand Tools
 Fasteners Wood Components
 Other _____
- What other companies do you purchase your tools and supplies from?

- Do you think your purchase represents good value?
 Yes No
- Would you recommend Grizzly Imports to a friend?
 Yes No
- Would you allow us to use your name as a reference for Grizzly customers in your area? **Note: We never use names more than three times.**
 Yes No
- Comments: _____

CUT ALONG DOTTED LINE

FOLD ALONG DOTTED LINE

Place
Stamp
Here



**GRIZZLY INDUSTRIAL, INC.
P.O. BOX 2069
BELLINGHAM, WA 98227-2069**

FOLD ALONG DOTTED LINE

Send a Grizzly Catalog to a friend:

Name _____
Street _____
City _____ State _____ Zip _____