



# International User Manual

English





## **WARNING**

Important Safety Information accompanies this device.

Indications, Contraindications, Warnings, Precautions and other Safety Information are contained in the V.A.C.<sup>®</sup> Therapy Safety Information Sheet, located in the transit case.

The ActiV.A.C.<sup>®</sup> Quick Reference Guide is located in a pocket on the inside of the Front Flap of the Carrying Case.

To reduce risk of serious or fatal injury, all caregivers and patients must carefully read and follow all user instructions and safety information that accompany KCI products.

If there are questions or if the V.A.C.<sup>®</sup> Therapy Safety Information Sheet or Quick Reference Guide are missing, immediately contact KCI. See back cover of this User Manual for country specific contact information.

# Table of Contents

<b>Important Safety Information Statement . . . . .</b>	<b>Inside Front Cover</b>
<b>Important Safeguards . . . . .</b>	<b>3</b>
<b>ActiV.A.C.® Therapy System Overview . . . . .</b>	<b>4</b>
<b>Introduction . . . . .</b>	<b>6</b>
<b>Patient Mode . . . . .</b>	<b>8</b>
Patient 'Home' Screen . . . . .	8
Common Screen Control Buttons . . . . .	8
Navigation Buttons . . . . .	9
<b>Patient Operating Instructions . . . . .</b>	<b>10</b>
Power the ActiV.A.C.® Therapy Unit On or Off . . . . .	10
Therapy On or Off . . . . .	10
Audio Pause . . . . .	10
<b>Help Menu. . . . .</b>	<b>11</b>
Changing Languages . . . . .	11
On-screen Operating Instructions . . . . .	11
<b>Battery Charging Instructions . . . . .</b>	<b>12</b>
Battery Charging Indicator Light . . . . .	13
Battery Charge Level Indicator . . . . .	13
<b>Canister Changes . . . . .</b>	<b>14</b>
Identifying Canister and Related Parts . . . . .	14
Changing the Canister . . . . .	15
Carrying Case Parts Identification . . . . .	16
Canister Change (in Carrying Case). . . . .	17
<b>Inserting the Therapy Unit into the Carrying Case . . . . .</b>	<b>20</b>
<b>Carrying Case Configurations . . . . .</b>	<b>21</b>
<b>Clinician Mode . . . . .</b>	<b>22</b>
Clinician Mode Home Screen . . . . .	22
Common Screen Control Buttons . . . . .	22
Navigation Buttons . . . . .	23
<b>Clinician Operating Instructions . . . . .</b>	<b>24</b>
Power the ActiV.A.C.® Therapy Unit On or Off . . . . .	24
Accessing Manual Therapy Settings . . . . .	25
Settings . . . . .	25
Pressure Settings . . . . .	26
Intensity Control . . . . .	26
'Continuous' and 'Intermittent' Modes . . . . .	27
Intermittent Settings . . . . .	27
Settings Confirmation . . . . .	28

(Continued on next page)

**Table of Contents (cont.)**

<b>Clinician Operating Instructions (cont.)</b>	
Settings Guide . . . . .	28
Settings Guide Confirmation . . . . .	30
<b>Starting Therapy . . . . .</b>	<b>31</b>
Seal Check™ Overview . . . . .	31
How to Use Seal Check™ (When Starting Therapy) . . . . .	32
Finding the Leak Using Seal Check™ . . . . .	32
Log Tool Overview . . . . .	33
How to Use Log Tool (When Starting Therapy) . . . . .	33
<b>View or Export Therapy History . . . . .</b>	<b>35</b>
View Therapy History . . . . .	35
Export Therapy History Report . . . . .	36
Troubleshooting USB or Infrared Export Problems . . . . .	36
<b>Clinician Help Menu . . . . .</b>	<b>37</b>
Changing to Patient or Clinician Mode . . . . .	37
<b>Clinician Utilities . . . . .</b>	<b>38</b>
Changing Time and Date . . . . .	38
Changing Pressure Units and Date Format . . . . .	39
Changing Screen Brightness . . . . .	39
Changing AC Light . . . . .	39
<b>Alerts and Alarms . . . . .</b>	<b>40</b>
<b>Important Information About Alerts and Alarms . . . . .</b>	<b>40</b>
Index of Alerts and Alarms . . . . .	40
<b>Frequently Asked Questions . . . . .</b>	<b>50</b>
<b>Standard Precautions . . . . .</b>	<b>52</b>
<b>Care and Cleaning . . . . .</b>	<b>53</b>
<b>Manufacturer Information . . . . .</b>	<b>55</b>
<b>Explanation of Symbols Used . . . . .</b>	<b>56</b>
<b>Specifications . . . . .</b>	<b>57</b>
<b>Customer Contact Information . . . . .</b>	<b>Back Cover</b>

Electronic Printed Document  
 User Responsible For Current Revision Level 340076 Rev B  
 Not For Commercial Print

## Important Safeguards



***WARNING: As with all prescription medical devices, failure to follow product instructions or adjusting settings and performing therapy applications without the express direction and/or supervision of your trained clinical caregiver may lead to improper product performance and the potential for serious or fatal injury. For medical questions, please consult a physician.***



Important Safety Information is located in the transit case and the ActiV.A.C.® Quick Reference Guide is located in a pocket on the inside of the Front Flap of the Carrying Case.

If the V.A.C.® Therapy Safety Information Sheet or Quick Reference Guide are missing, immediately contact KCI for a replacement. See back cover for contact information.

In order for KCI products to provide safe and proper performance:

- The product must be used in accordance with this manual.
- It is recommended that the ActiV.A.C.® Therapy Unit always be kept in the Carrying Case when in use.
- The ActiV.A.C.® Therapy System may present a tripping hazard if placed on the floor. Ensure that the ActiV.A.C.® Therapy Unit is not placed in areas where people may walk.
- **Please note:** To help provide safe and effective use, V.A.C.® Dressings are only to be used with V.A.C.® Therapy Units.
- All assembly, adjustment, modification, maintenance and/or repair should be carried out by qualified personnel authorized by KCI.
- The electrical installation of the room must comply with the appropriate electrical wiring standards.
- Refer to the **Standard Precautions** section of this manual for information on infection control procedures. Refer to the **Care and Cleaning** section for recommended daily and weekly cleaning for the ActiV.A.C.® Therapy Unit.
- Never operate this product if it has a damaged power cord, power supply or plug. Should the power cord, power supply or plug be found to be worn or damaged, contact KCI. See back cover.
- Never drop or insert any object into any opening or tubing of the ActiV.A.C.® Therapy System.
- Do not connect or attach V.A.C.® Therapy units or its components, to devices not recommended by KCI.
- Keep the ActiV.A.C.® Therapy System away from heated surfaces.
- Although the ActiV.A.C.® Therapy System conforms to the intent of the standard IEC 60601-1-2 in relation to Electromagnetic Compatibility, electrical equipment may produce interference. If interference is suspected, separate the equipment and contact KCI. See back cover.



***Liquids remaining on the electronic controls can cause corrosion that may cause the electronic components to fail. Component failures may cause the unit to operate erratically, possibly producing potential hazards to patient and staff.***



- Avoid spilling fluids on any part of the ActiV.A.C.® Therapy Unit.
- If spills do occur, unplug the unit immediately if plugged into electrical source and clean the unit with an absorbent cloth. Ensure there is no moisture in or near the Power Connection and Power Supply Components before reconnecting power. If the ActiV.A.C.® Therapy Unit is not working properly, contact KCI. See back cover of this User Manual for country specific contact information.



- Do not use ActiV.A.C.® Therapy Unit while bathing/showering or where it can fall or be pulled into a tub, shower or sink.
- Do not reach for a product that has fallen into water. Unplug the unit immediately if plugged into electrical source. Disconnect the unit from dressing and contact KCI. See back cover.

## ActiV.A.C.® Therapy System Overview

Specific features are detailed in the Patient Feature Identification section of this manual.

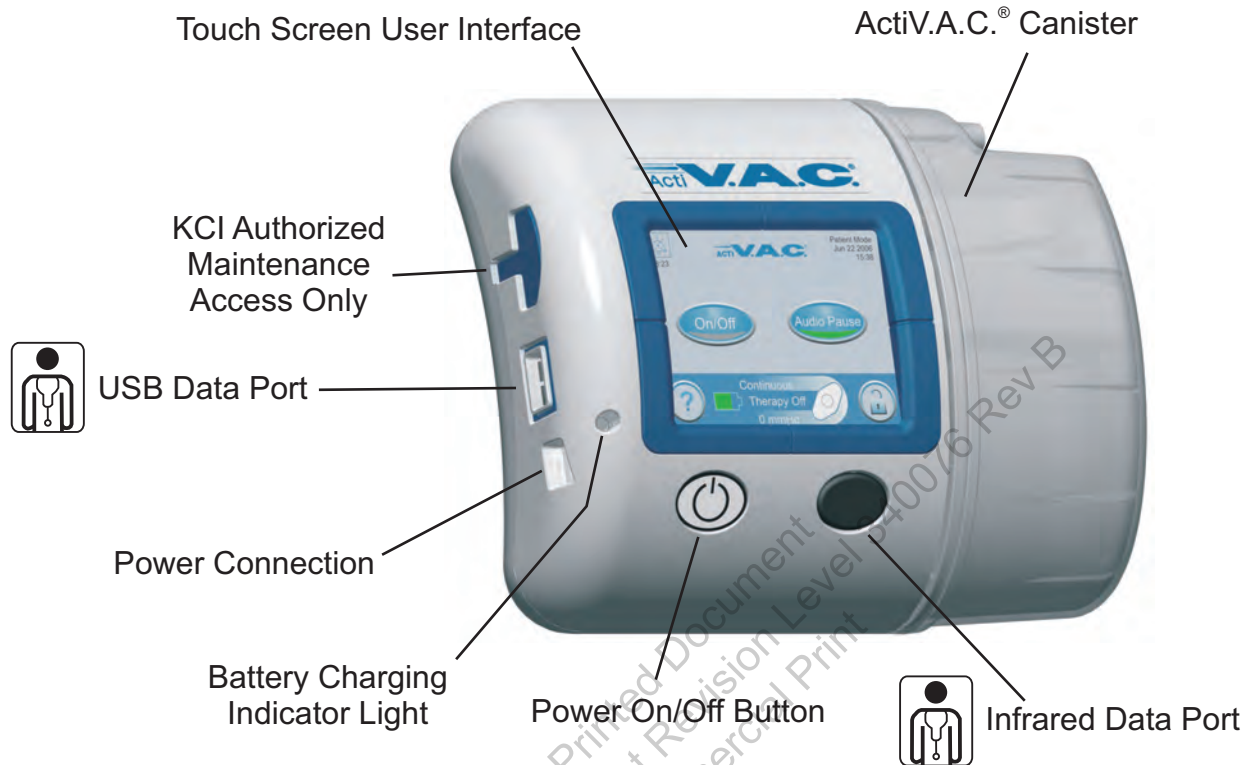

### Typical V.A.C.® Dressing (Not included with therapy unit)



**i** A variety of V.A.C.® Dressings are available for use with the ActiV.A.C.® Therapy System.

## ActiV.A.C.<sup>®</sup> Therapy System Overview

### ActiV.A.C.<sup>®</sup> Power Supply Components

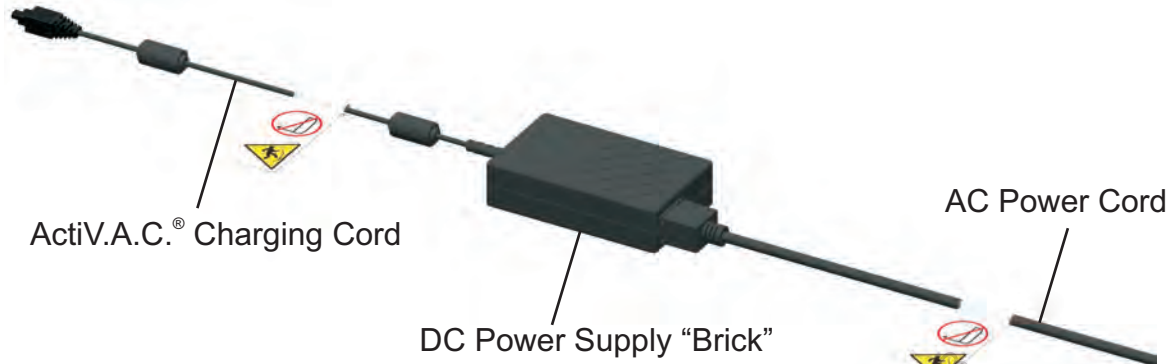

### ActiV.A.C.<sup>®</sup> Carrying Case and Adjustable Strap

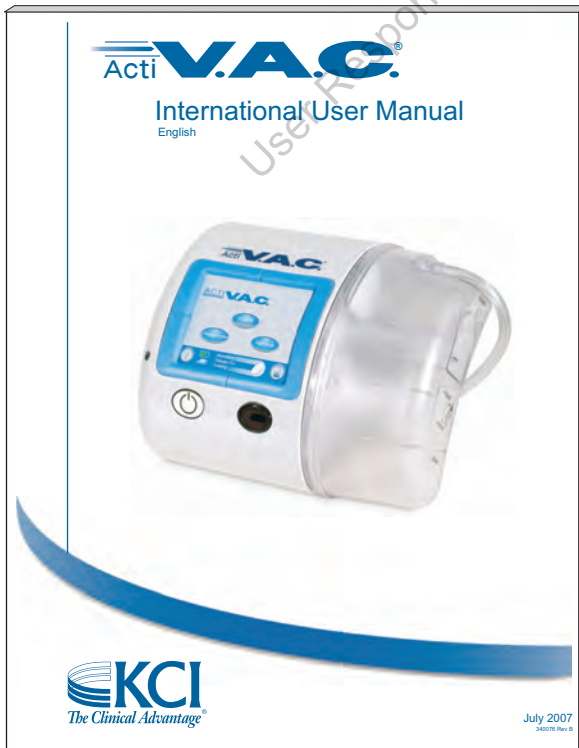

### ActiV.A.C.<sup>®</sup> Quick Reference Guide

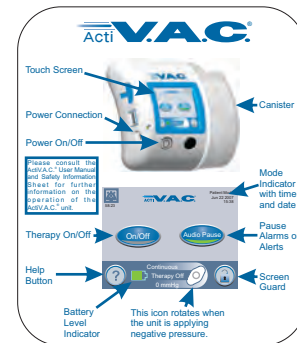

## Introduction

V.A.C.<sup>®</sup> is short for Vacuum Assisted Closure. V.A.C.<sup>®</sup> Therapy is a system that uses controlled negative pressure (vacuum) to create an environment that promotes wound healing by bringing the wound edges together, reducing edema, promoting granulation tissue formation and perfusion, and by removing wound fluids and infectious material. It is a flexible therapy in that, with appropriate precautions in place, may be used in most instances in both hospital and community settings. This advanced wound healing technology, coupled with microprocessor-controlled therapy units, and first-class technical back-up, helps provide peace of mind for both clinicians and patients.

The V.A.C.<sup>®</sup> family of devices is used to help promote wound healing through multiple mechanisms of action under the influence of continuous and/or intermittent negative pressure in association with wound-site feedback control (SensaT.R.A.C.<sup>®</sup> technology). The ActiV.A.C.<sup>®</sup> Therapy System is a Vacuum Assisted Closure<sup>®</sup> System that provides Negative Pressure Wound Therapy (NPWT) and Therapeutic Regulated Acute Care (SensaT.R.A.C.<sup>®</sup>) for use on a variety of chronic and acute wound types.



**V.A.C.<sup>®</sup> Therapy is prescribed by a physician or other licensed prescriber. The therapy should only be administered by a medical practitioner. Patients should not attempt to perform a change of settings and/or therapy application without the express permission of the treating physician and/or under the supervision of a trained clinical caregiver.**



**Important product and therapy indications, contraindications, precautions and safety information apply. Please consult your clinician, the accompanying V.A.C.<sup>®</sup> Therapy Safety Information Sheet, (located in the transit case) Quick Reference Guide (located in the pocket on the inside of the Front Flap of the Carrying Case) and this User Manual prior to use.**

## ActiV.A.C.<sup>®</sup> Therapy System Key Features

### Touch Screen User Interface

The Touch Screen User Interface allows for easy navigation through operational and help menus. A Screen Guard is available to help prevent unintentional changes.

### Battery Operation

In order to facilitate mobility and help patients return to daily activities, battery operation is available with the ActiV.A.C.<sup>®</sup> Therapy Unit. During typical usage, the battery may provide up to 14 hours of operation before needing to be recharged.

### On-Screen Operating Instructions

Abbreviated “Operating Instructions” are available on-screen. Always familiarize yourself with and refer to this manual for detailed and specific information for use.

### Seal Check<sup>™</sup> Tool

This tool assists in finding air leaks in the SensaT.R.A.C.<sup>®</sup> System and dressing through the use of audible tones and on-screen visual aids during the troubleshooting process.

### Carrying Case

A convenient Carrying Case is provided to allow discreet delivery of therapy. It is recommended that the ActiV.A.C.<sup>®</sup> Therapy Unit always be kept in the Carrying Case.



## Introduction (cont.)



### Patient Mode Control

Selection of Patient Mode by the clinician can help prevent unauthorized access to therapy set-up screens. Patient Mode allows the patient to have access to appropriate screen menus.



### Therapy History Report

A chronological log with date and times for therapy starts/stops, therapy settings, alarm occurrences, and canister/dressing changes can be reviewed on-screen or transferred from the ActiV.A.C.<sup>®</sup> Therapy Unit electronically in the form of a Therapy History Report. This electronic transfer can be accomplished by accessing the Infrared Data Port or by inserting a USB flash memory stick into the USB Data Port.



**The USB Data Port is to be used with non-powered memory sticks and drives only. No AC or battery powered drives, computers, computer equipment, or other devices may be used.**



### Settings Guide

V.A.C.<sup>®</sup> Therapy set-up menus are available on-screen to assist in the selection of therapy settings by wound type.



### SensaT.R.A.C.<sup>®</sup> System

The SensaT.R.A.C.<sup>®</sup> System monitors and maintains target pressure at the wound site, helping to deliver consistent therapy. This system includes therapy unit hardware, software, wound exudate collection canister, canister detection method, multi-lumen tubing, connector and SensaT.R.A.C.<sup>®</sup> Pad.

### In-Line Canister/Dressing Connectors

The SensaT.R.A.C.<sup>®</sup> System incorporates an in-line dressing connector and tubing clamps to conveniently allow the wound dressing to be temporarily disconnected from the ActiV.A.C.<sup>®</sup> Therapy Unit.

### 300 ml Canister

The ActiV.A.C.<sup>®</sup> Therapy Unit offers a single use, latex-free, sterile 300 ml wound exudate collection canister.



### Intensity Setting

Intensity is related to the time it takes to reach the target therapy level after the initiation of therapy. The lower the intensity setting, the slower the target therapy level will be reached.



### Therapy Days Display

Screen will display the number of days since V.A.C.<sup>®</sup> Therapy was first initiated on the patient.

### V.A.C.<sup>®</sup> Dressings

A variety of V.A.C.<sup>®</sup> Dressings are available for use with the ActiV.A.C.<sup>®</sup> Therapy System.



Refer to the Standard Precautions section of this manual for information on infection control procedures. Refer to the Care and Cleaning section for recommended daily and weekly cleaning for the ActiV.A.C.<sup>®</sup> Therapy Unit.

## Patient Mode

### Patient 'Home' Screen

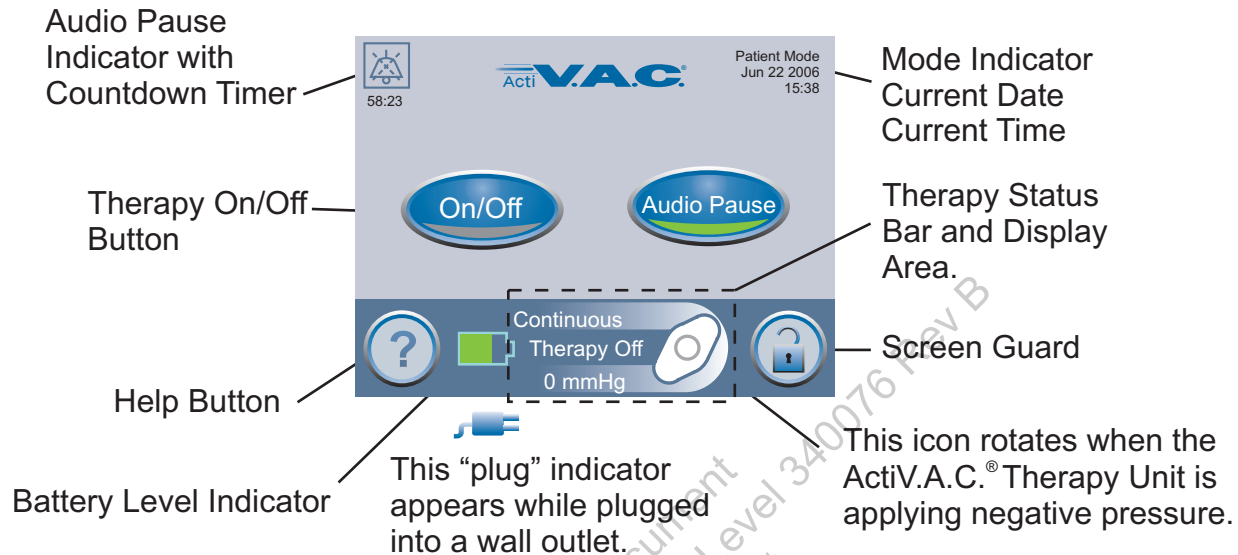

A green lighted crescent means the function is on



An unlit crescent means the function is off.



starts or stops V.A.C.<sup>®</sup> Therapy.



When the Audio Pause button is selected, alerts that do not need immediate attention will be silenced for 60 minutes. A Countdown Timer and Audio Pause Indicator will be displayed in the upper left hand corner of the screen.



**Alarms needing immediate attention override this feature.**

### Common Screen Control Buttons

Most screens have one or more common control buttons. These are:



accesses **Help** screens.



activates the **Screen Guard** feature to help prevent unintentional changes. This feature should be used when cleaning the Touch Screen User Interface.

**To release Screen Guard, press '1' and then '2'.**

## Patient Mode (cont.)

### Navigation Buttons

One or more of these buttons may appear on a screen.

 **Exit** leaves that particular screen.

 **Cancel** stops action in progress.

 **Next** goes to the next screen of that particular procedure.

 **Back** returns to the previous screen of that particular procedure.

 **OK** acknowledges the action is complete and displays the next screen.

Electronic Printed Document  
User Responsible For Current Revision Level 340075 Rev B  
Not For Commercial Print

## Patient Operating Instructions

### Power the ActiV.A.C.<sup>®</sup> Therapy Unit On or Off



Press and hold the **Power On/Off** button for approximately 2 seconds to turn the ActiV.A.C.<sup>®</sup> Therapy Unit On or Off.

The Power On/Off button is located immediately below and to the left of the Touch Screen User Interface. Refer to the Patient Feature Identification section for more information.

The ActiV.A.C.<sup>®</sup> Therapy Unit will go through a self-check routine and then presents a '**Warning Message**' screen. Press '**OK**' to continue to the Patient Mode Home screen (shown below).

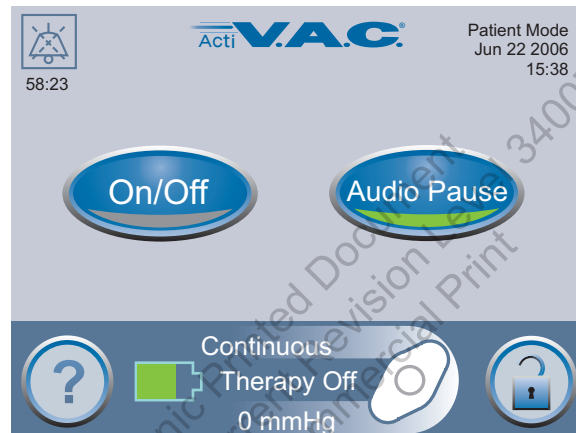

### Therapy On or Off



starts or stops V.A.C.<sup>®</sup> Therapy.



green crescent on the On/Off button means V.A.C.<sup>®</sup> Therapy is on.



**WARNING:** Under clinician supervision, replace V.A.C.<sup>®</sup> Dressing with alternate dressing if therapy is interrupted for more than two hours.

### Audio Pause



When the Audio Pause button is selected, alerts that do not need immediate attention will be silenced for 60 minutes.



58:23

A Countdown Timer and Audio Pause Indicator will be displayed in the upper left hand corner of the screen



Alarms needing immediate attention override the Audio Pause feature. See the Alerts and Alarms section of this manual for details on alarms and how to resolve them.

## Help Menu

### Changing Languages

Press  to access the 'Help Menu'.

Press the 'Globe' (upper left) to access the 'Language' screen.

Use the  buttons to select the required language.

 **WARNING:** Languages should only be selected according to local regulatory requirements.

Press  when finished.

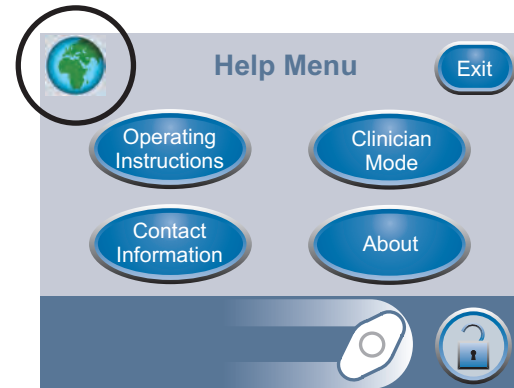

### On-screen Operating Instructions

Press  to access the 'Help Menu'.

Press 'Operating Instructions' to access the 'Operating Instructions' selection screen.

From this 'Operating Instructions' screen, one can browse the various 'Help Screens' that are available.

Choose from:

- 'Operation' instructions,
- 'Cleaning' instructions and
- 'Alarms' for alarm descriptions and their suggested resolutions.

Press  when finished.

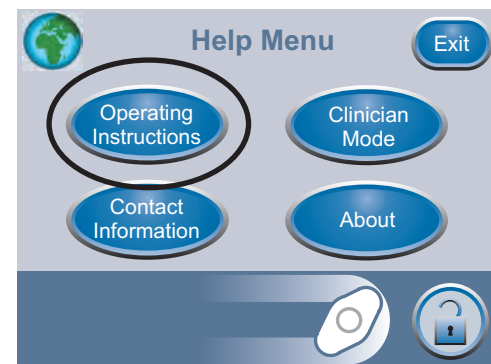

## Battery Charging Instructions

**!** Use only the power supply provided with the ActiV.A.C.® Therapy Unit. Using any other power supply may damage the ActiV.A.C.® Therapy Unit.

**!** If environmental conditions (specifically, low humidity) pose a risk of static electricity, care should be taken when handling the ActiV.A.C.® Therapy Unit when it is out of the Carrying Case and plugged into an AC wall outlet. In rare instances, discharge of static electricity when in contact with the therapy unit may cause the Touch Screen User Interface to darken, the therapy unit to reset or the therapy unit to turn off. If unable to restart therapy by powering the therapy unit off and then on, immediately contact KCI. See back cover of this User Manual for country specific contact information.

**!** **WARNING:** Under clinician supervision, replace V.A.C.® Dressing with alternate dressing if therapy is interrupted for more than two hours.

**⚠** Power cords may present a tripping hazard. Ensure that all cords are out of areas where people may walk.

**i** The ActiV.A.C.® Therapy Unit comes with a rechargeable battery. The battery is not user accessible or serviceable.

**i** The power supply has a two-part cord; one that plugs into an AC wall outlet and one that plugs into the ActiV.A.C.® Therapy Unit.

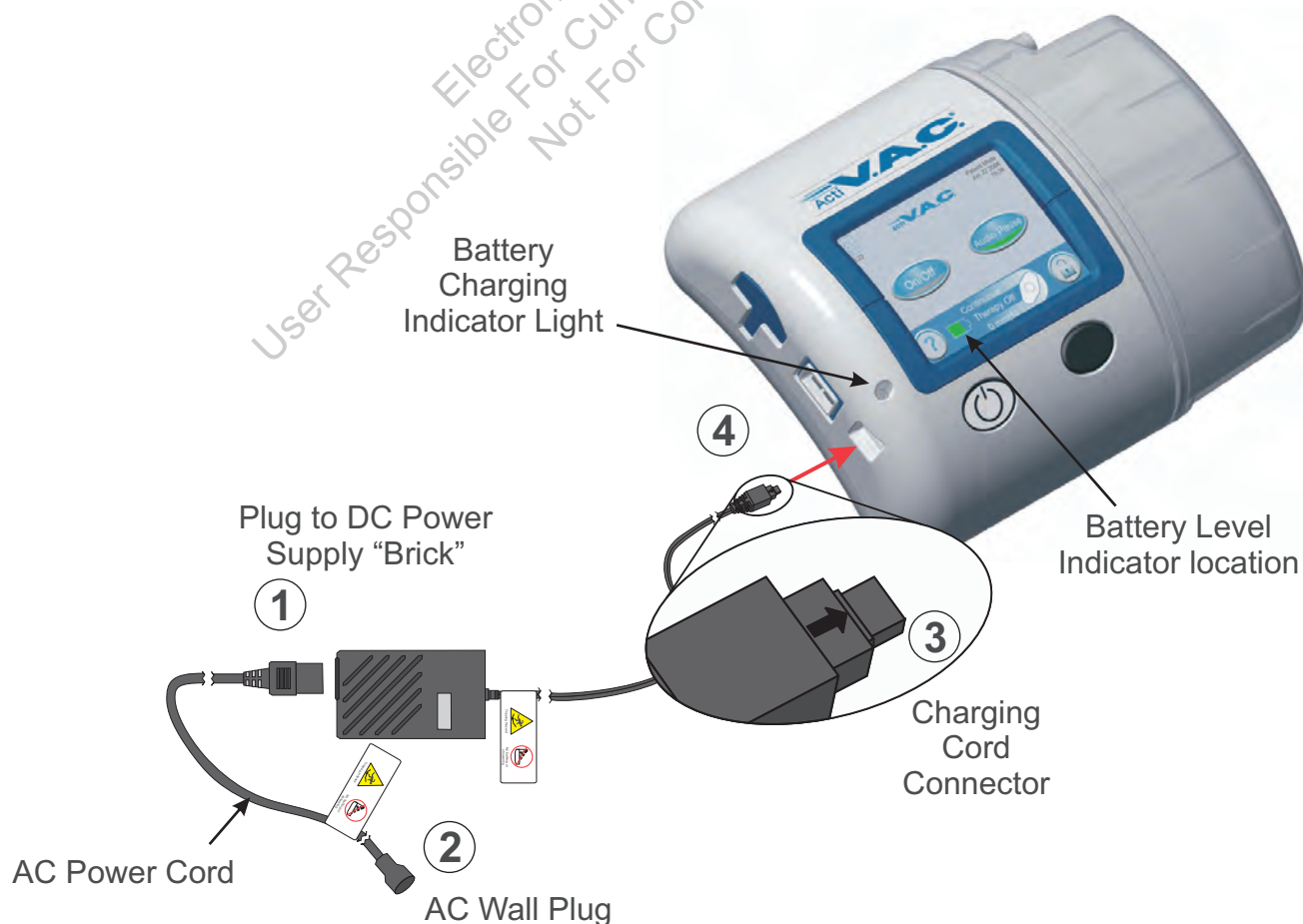

## Battery Charging Instructions (cont.)

Steps are numbered in order. See picture on previous page.

- ① Plug the AC Power Cord into the DC Power Supply “Brick”.
- ② Plug the AC Wall Plug into an AC wall outlet.
- ③ Locate the “Arrow” on the ActiV.A.C.® Charging Cord Connector.
- ④ With ActiV.A.C.® Touch Screen User Interface facing up, the “Arrow” should also be up as the Charging Cord Connector is plugged into the Power Connection on the ActiV.A.C.® Therapy Unit.

 It should take approximately 6 hours to fully recharge the battery from a completely discharged state.

 To maximize battery life, keep the unit plugged in when the patient is not mobile for significant periods.

### Battery Charging Indicator Light

When the ActiV.A.C.® Therapy Unit is correctly plugged into the ActiV.A.C.® Power Supply, the **Battery Charging Indicator Light** will glow **Amber** as the battery is charging.

When the battery has reached full charge the **Battery Charging Indicator Light** will glow **Green**.

### Battery Level Indicator

The battery level is shown on the bottom of the Touch Screen User Interface.



Fully  
Charged



In  
Use



Battery  
Low  
(Charge battery soon)



Battery  
Critical  
(Charge battery  
*immediately*)

## Canister Changes

### Identifying Canister and Related Parts

**!** *Canister Latch Guide on the therapy unit may have sharp edges. Do not handle the ActiV.A.C.<sup>®</sup> Therapy Unit by the Canister Latch Guide.*

**!** *When not in use, always store the ActiV.A.C.<sup>®</sup> Therapy Unit in the Carrying Case without a canister in place.*

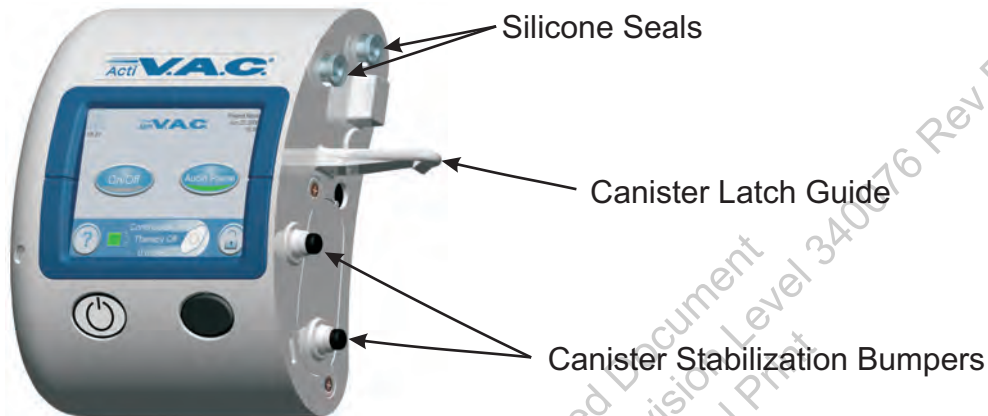



**i** Contact KCI if the Silicone Seals, Canister Latch Guide or the Canister Stabilization Bumpers are damaged or missing. See back cover of this User Manual for country specific contact information.



**!** *Canister is always applied straight on and straight off the ActiV.A.C.<sup>®</sup> Therapy Unit. Do not twist or turn canister when installing or removing.*



## Changing the Canister

-  See **Canister Change (in Carrying Case)** section for change instructions when in the Carrying Case.
-  The ActiV.A.C.<sup>®</sup> Canister should be changed when full (the alarm will sound), or at least once a week to control odor.
-  V.A.C.<sup>®</sup> Therapy is already off if addressing a Canister Full Alarm.

1. Stop V.A.C.<sup>®</sup> Therapy by pressing  on the Touch Screen User Interface.

 Do not turn power off to the ActiV.A.C.<sup>®</sup> Therapy Unit.

2. Slide both tubing clamps toward the tubing connector. See picture ②.
3. Tightly close both tubing clamps. (Several clicks should be heard). See picture ③.
4. Disconnect the dressing tubing from the canister tubing by:
  - (1.) twisting the tubing connectors until the locking tabs are disengaged,
  - (2.) pulling the connector apart. See picture ④.

5. Depress the Canister Latch Release. See picture ⑤.

6. Remove the canister from the therapy unit by pulling the canister directly away from the unit. See picture ⑥.

-  Dispose of the canister according to institution and local environmental regulations.

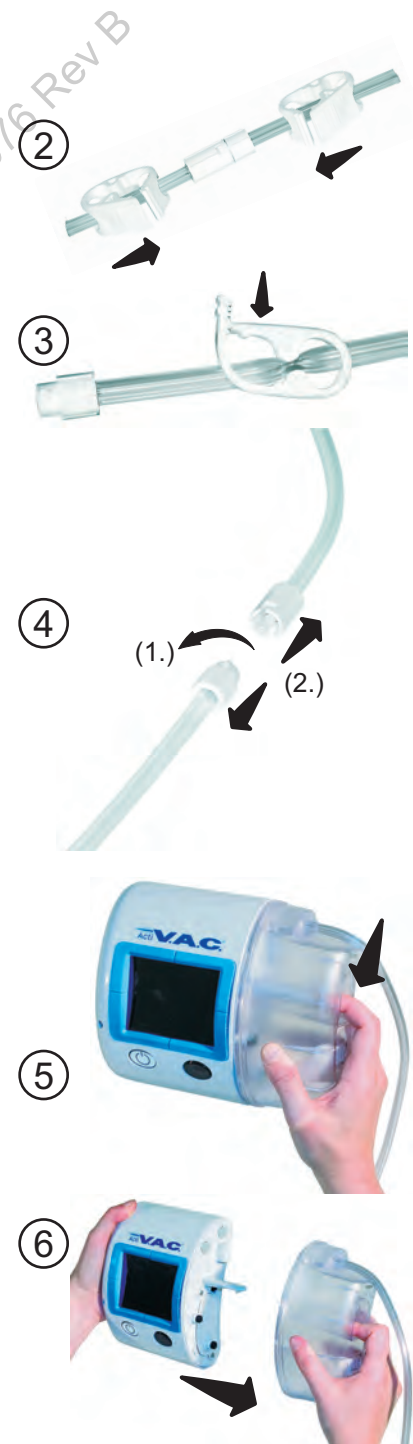

### Changing the Canister (cont.)

7. Install the new canister onto the therapy unit by sliding the opening in the canister over the Canister Latch Guide. Ensure the canister is installed directly onto the therapy unit. See picture (7).

Do not twist or turn the canister as it is being installed.

An audible “click” should be heard when canister is properly installed.



8. Ensure the canister is securely installed on the therapy unit. If the canister is properly installed, the canister cannot be removed by gently pulling the canister directly away from the unit. See picture (8).



9. Reconnect the new canister tubing to the dressing tubing by:

- (1.) pushing the connectors together and
- (2.) twisting the connectors until the locking tabs are fully engaged. See picture (9).

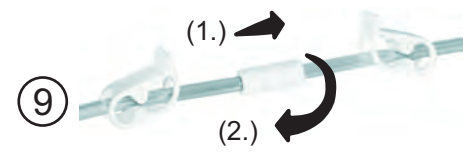

10. Open both tubing clamps. See picture (10).



11. Press  on the Touch Screen User Interface to restart V.A.C.<sup>®</sup> Therapy. Verify the dressing compresses.

### Carrying Case Parts Identification (rear view)



## Canister Change (in Carrying Case)

1. Open the Front Flap on the Carrying Case. See picture ①.

 V.A.C.® Therapy is already off if addressing a Canister Full Alarm.

Stop V.A.C.® Therapy by pressing  on the Touch Screen User Interface. See picture ①.

 Do not turn power off to the ActiV.A.C.® Therapy Unit.

2. Slide both tubing clamps toward the tubing connector. See picture ②.
3. Tightly close both tubing clamps. (Several clicks should be heard). See picture ③.
4. Disconnect the dressing tubing from the canister tubing by:
  - (1.) twisting the tubing connectors until the locking tabs are disengaged,
  - (2.) pulling the connector apart. See picture ④.
5. Close the Front Flap and turn the ActiV.A.C.® Therapy Unit over so that its Front Flap is facing down. See picture ⑤.

6. Unzip the Tubing Storage Pocket Zipper. See picture ⑥.  
Remove the tubing from the Tubing Storage Pocket.

7. Unzip the Center Zipper on the back of the case. Undo the Hook and Loop Fastener on the Access Flap and fold the Access Flap back to begin to expose the canister. See picture ⑦.

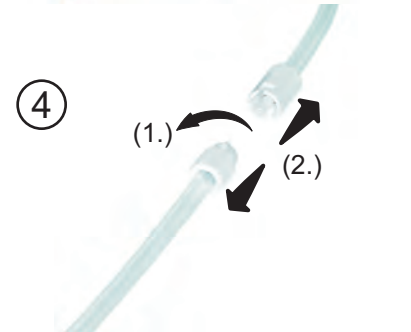

**Canister Change (in Carrying Case) cont.**

8. Grasp the ActiV.A.C.<sup>®</sup> Therapy Unit in one hand and turn the unit and case so that the canister is facing up. Continue to fold the Access Flap back until the canister is fully exposed.

See pictures (8a) and (8b).

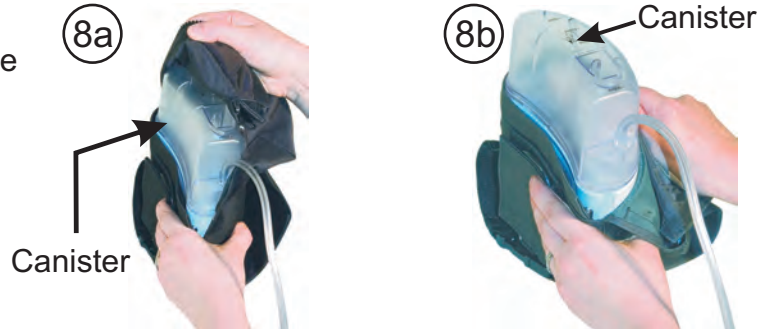

9. Position the ActiV.A.C.<sup>®</sup> Therapy Unit so that the Canister Latch Release can be pressed toward the 50ml graduation mark. See picture (9a).

Press the Canister Latch Release and remove the canister from the therapy unit. See pictures (9a) and (9b).

**i** Dispose of the canister according to institution and local environmental regulations.

10. Install the new canister onto the ActiV.A.C.<sup>®</sup> Therapy Unit by sliding the opening in the canister over the Canister Latch Guide. Do not twist or turn the canister as it is being installed. See picture (10a).

Push the canister onto the therapy unit. An audible “click” should be heard. See picture (10b).

11. Ensure the canister is securely installed on the therapy unit. If the canister is properly installed, the canister cannot be removed by gently pulling the canister directly away from the therapy unit.

**!** **Ensure that no part of the case is between the canister and the ActiV.A.C.<sup>®</sup> Therapy Unit.**

12. Pull the Access Flap back over the canister and ActiV.A.C.<sup>®</sup> Therapy Unit so that the canister is covered by the case.

See pictures (12a) and (12b).

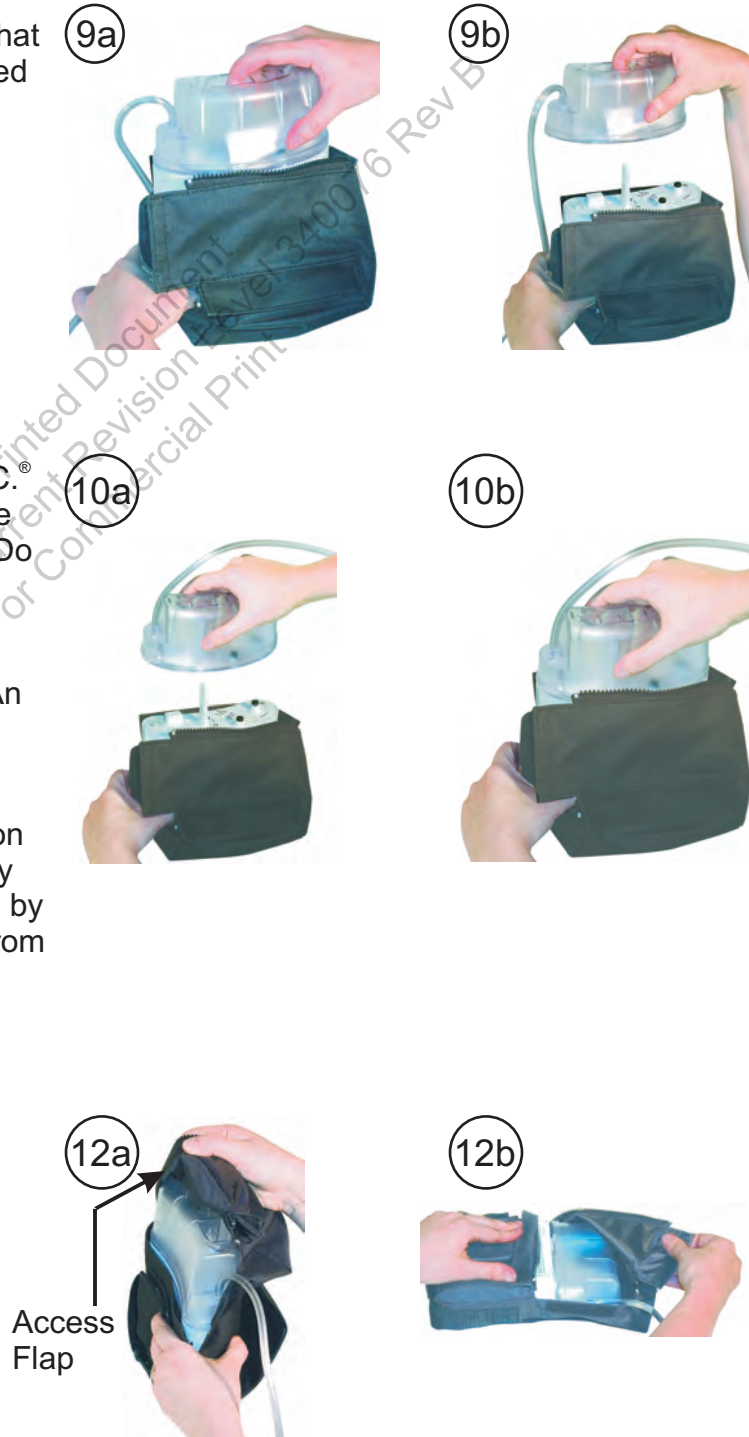

**Canister Change (in Carrying Case) cont.**

13. Secure the Hook and Loop Fastener.  
See Picture (13a).

(13a)



(13b)



Close the Center Zipper over the canister. See picture (13b).

14. Reconnect the new canister tubing to the dressing tubing by:

(14a)

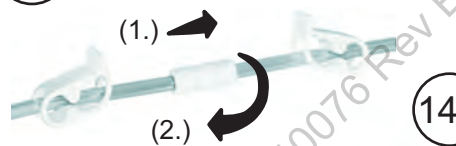

- (1.) pushing the connectors together and
- (2.) twisting the connectors until the locking tabs are fully engaged. See picture (14a).

(14b)

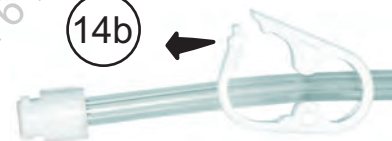

Open both tubing clamps. See picture (14b).

15. Wrap any excess tubing into a bundle and put the tubing into the Tubing Storage Pocket on the bottom of the Carrying Case. See picture (15a).

(15a)



(15b)



**Ensure there are no kinks or the tubing is not pinched as it is put in the Tubing Storage Pocket.**



**Excess tubing may present a tripping hazard. Ensure that excess tubing is stored in the tubing pocket and is out of areas where people may walk.**

Close the Tubing Storage Pocket Zipper. See picture (15b).

16. Picture (16) shows the Carrying Case with the zippers and flaps in their final position. (16)

(16)



(17)



17. Turn the Carrying Case front side up. Open the Front Flap and restart V.A.C.<sup>®</sup>

Therapy by pressing 

See picture (17).

18. When finished, close the Front Flap.

## Inserting the Therapy Unit into the Carrying Case

①



Start with the empty case. Open the Center Zipper and Access Flap.

②



Hold the case open, and with a canister attached and the Touch Screen User Interface facing down, slide the ActiV.A.C.<sup>®</sup> Therapy Unit into the case.

③



Continue to slide the unit into the case until it fits.

④



After the ActiV.A.C.<sup>®</sup> Therapy Unit is completely in the case, fold the Access Flap over the therapy unit.

⑤



Close the Center Zipper.

⑥



Wrap any excess tubing into a bundle. Put the tubing into the Tubing Storage Pocket on the bottom of the Carrying Case. Ensure there are no kinks or the tubing is not pinched as it is put in the Tubing Storage Pocket.



**Excess tubing may present a tripping hazard. Ensure that excess tubing is stored in the tubing pocket and is out of areas where people may walk.**

⑦



Close Tubing Storage Pocket Zipper.

⑧



Finished position with zippers and flaps closed.

## Carrying Case Configurations



The case can be worn over the shoulder with the strap adjusted for comfort.



The case can be worn over the opposite shoulder with the strap adjusted for comfort.



A personal belt can be threaded through the Built-in Belt Loop on the back of the case. The Shoulder Strap should be removed and the loose Buckles connected over the top of the case.



The attached Shoulder Strap can be removed from the Buckles and threaded through the Built-in Belt Loop on the back of the case. The loose Buckles should be connected over the top of the case.



The case has a built-in Multi-function Hook located under a flap on the back of the case. The case can be used with the Shoulder Strap removed, the loose Buckles connected over the top of the case, and the Multi-function Hook over the top of a chair or other secure location.



The ActiV.A.C.<sup>®</sup> Therapy Unit can be carried in the hand by removing the shoulder strap and connecting the loose Buckles over the top of the case.



**Excess tubing may present a tripping hazard. Ensure that excess tubing is stored in the tubing pocket and is out of areas where people may walk.**



When worn or carried, therapy unit should always have the canister pointing down. Ensure that the Buckles are properly snapped together.

## Clinician Mode

### Clinician Mode Home screen

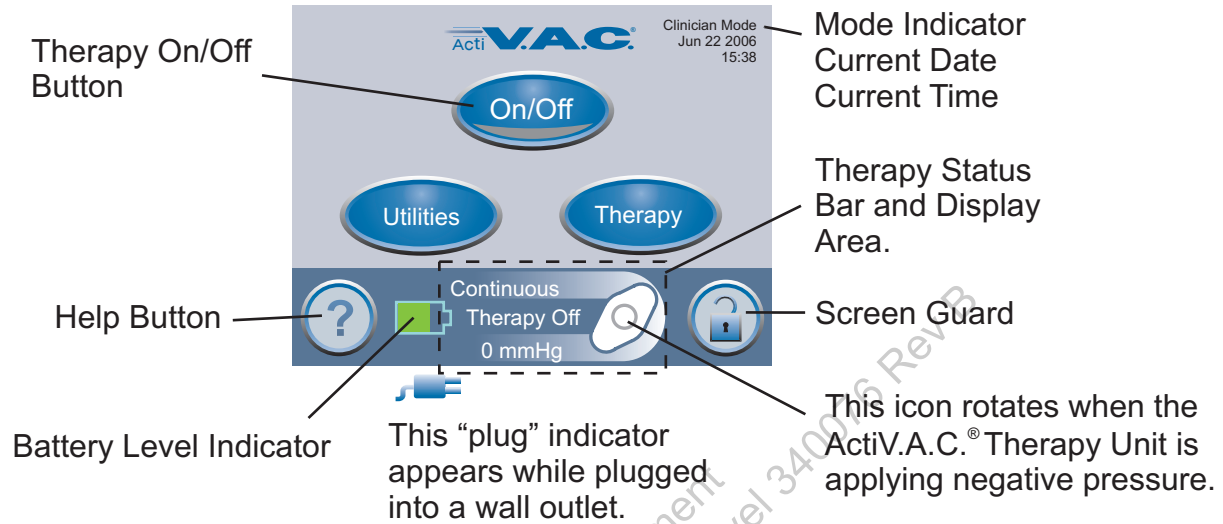

A green lighted crescent means the function is on.



An unlit crescent means the function is off.



**On/Off** starts or stops V.A.C.<sup>®</sup> Therapy.



**Utilities** accesses 'Region Settings' and 'Time/Date' access buttons, 'Screen Brightness' and 'AC Light' buttons.



**Therapy** accesses 'Settings', 'Seal Check™' Tool, 'Settings Guide', and 'History' access buttons.

### Common Screen Control Buttons

Most screens have one or more common control buttons. These are:



accesses **Help** screens when available.



activates the **Screen Guard** feature to help prevent unintentional changes. This feature should be used when cleaning the Touch Screen User Interface.

**To release Screen Guard, press '1' and then '2'.**



**Screen Guard is not a patient lock-out feature.**



## Clinician Mode (cont.)

### Navigation Buttons

One or more of these buttons may appear on a screen.

 leaves that particular screen.

 stops action in progress.

 goes on to the next screen of that particular procedure.

 returns to the previous screen of that particular procedure.

 acknowledges the action is complete and displays the next screen.

 Holding these buttons will rapidly scroll through available selections.

Electronic Printed Document  
User Responsible For Current Revision Level 30076 Rev B  
Not For Commercial Print

## Clinician Operating Instructions



### CAUTION NOTICE TO PATIENTS:

*This section contains specific information intended for clinicians ONLY. Do not attempt to perform any applications or setting adjustments in this section without the express direction and supervision of your treating physician.*



The ActiV.A.C.® Therapy Unit should be delivered already set to the Clinician Mode.



The ActiV.A.C.® Therapy Unit will return to the Patient Mode after about 15 minutes of Touch Screen User Interface inactivity. Refer to Clinician Help Menu section of this manual if necessary.

### Power the ActiV.A.C.® Therapy Unit On or Off



Press and hold the **Power On/Off** button for approximately 2 seconds to turn the ActiV.A.C.® Therapy Unit On or Off.

The Power On/Off button is located immediately below and to the left of the Touch Screen User Interface.

The ActiV.A.C.® Therapy Unit will go through a self-check routine and then presents a **'Warning Message'** screen. Press **'OK'** to continue to this Clinician Mode Home screen (shown below).



## Therapy

### Accessing Manual Therapy Settings

From the Clinician Mode Home screen, press **'Therapy'**, then **'Next'** to access the Therapy screen.

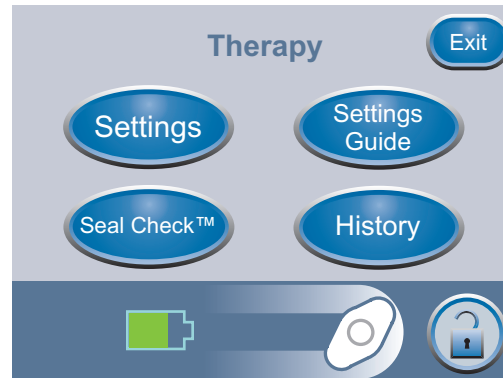

From the **'Therapy'** screen the clinician can access:

- **'Settings'** - Manually set therapy.
- **'Seal Check™'** - Assists in finding leaks.
- **'Settings Guide'** - Guide for preset therapy settings.
- **'History'** - View or export therapy history.

Press **'Exit'** to return to the Clinician Home screen.

### Settings



**Settings changed manually take immediate effect when therapy is on.**

From the Clinician Mode Home screen, press **'Therapy'**, then **'Next'**, then **'Settings'** to access the Settings screen.

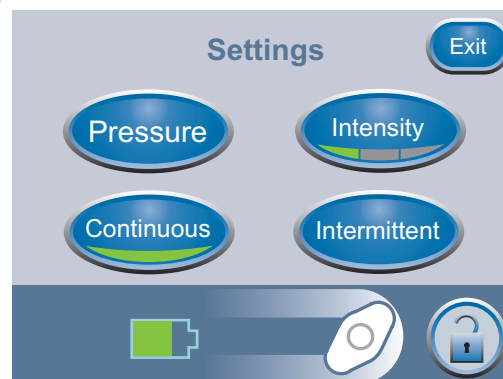

From the **'Settings'** screen the clinician can:

- Change **'Pressure'** settings.
- Change **'Intensity'**.
- Toggle between **'Continuous'** and **'Intermittent'** therapy.
- Set **'Intermittent'** therapy times.

Press **'Exit'** when finished with the 'Settings' screen and go to the 'Confirm' screen.

## Settings (cont.)

## Pressure Settings



**Settings changed manually take immediate effect when therapy is on.**

From the Clinician Mode Home screen, press 'Therapy', then 'Next', then 'Settings', then 'Pressure' to access the Pressure screen.

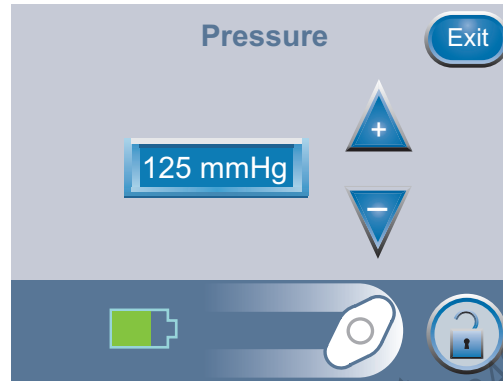

Use the  buttons to change to the desired pressure.

Pressure can be set from 25 to 200 mmHg in increments of 25 mmHg.

Press 'Exit' to return to the 'Settings' screen.



Default setting is: 125 mmHg

## Intensity Control



**Settings changed manually take immediate effect when therapy is on.**

From the Clinician Mode Home screen, press 'Therapy', then 'Next', then 'Settings' to access the Intensity button.

- Intensity is related to the time it takes to reach the target therapy level after the initiation of therapy.
- The lower the intensity setting, the slower the target therapy level will be reached.
- It is recommended that new patients begin therapy at the lowest intensity setting as this allows for slower increase of negative pressure once the foam is compressed in the wound.
- The intensity can remain at the minimum setting throughout the entire length of treatment, if desired.

Press to change levels. Green crescent changes with each setting.



Default setting is: Low

## Settings (cont.)

### 'Continuous' and 'Intermittent' Modes

From the Clinician Mode Home screen, press **'Therapy'**, then **'Next'**, then **'Settings'** to access this screen.

Press  to switch between **'Continuous'** and **'Intermittent'** Therapy.

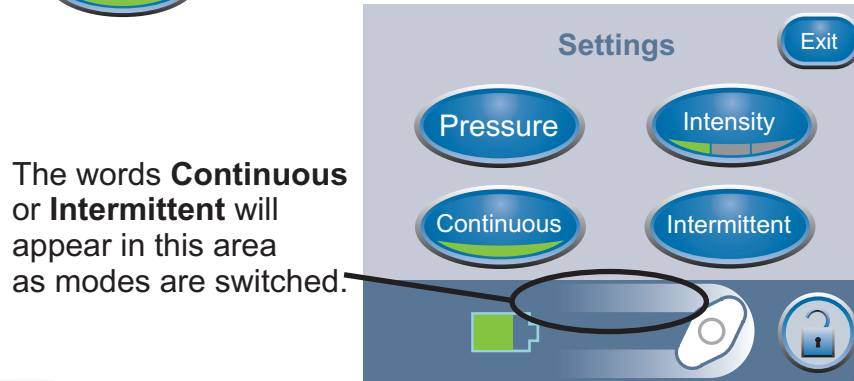

 When the Green Crescent is lit, the ActiV.A.C.® Therapy Unit is in **'Continuous'** mode.

 When the Green Crescent is unlit, the ActiV.A.C.® Therapy Unit is in **'Intermittent'** mode.

 Default setting is: Continuous.

Press **'Exit'** when finished with the 'Settings' screen and go to the 'Confirm' screen.

### Intermittent Settings

 **Changing Intermittent time intervals will take effect next cycle.**

From the Clinician Mode Home screen, press **'Therapy'**, then press **'Settings'**, then press **'Intermittent'** to access this screen.

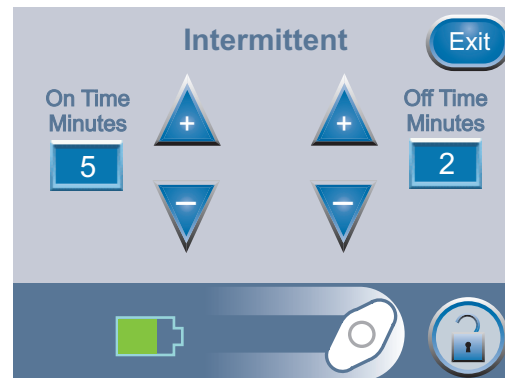

Use the  buttons to change the desired On and Off Time (in minutes).

Both On and Off Times can be set from 1 minute to 10 minutes in 1 minute increments.

 Default setting is: On Time = 5 minutes. Off Time = 2 minutes.

Press **'Exit'** to return to the 'Settings' screen.

## Settings (cont.)

## Settings Confirmation

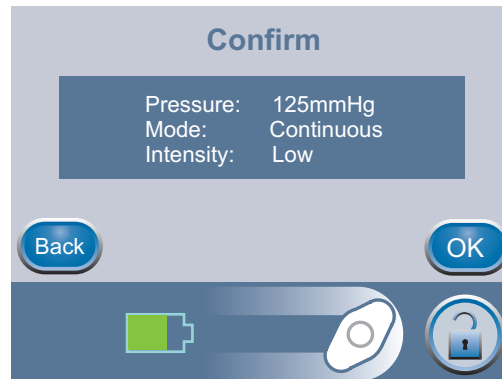

Pressing  when finished with the 'Settings' screen leads to this 'Confirm' screen.



If the displayed settings are as desired, press 'OK' to continue to the Clinician Mode Home screen. Otherwise, press 'Back' to change any settings that are incorrect.

 If settings were changed with V.A.C.® Therapy off, press  to start therapy.

## Settings Guide

-  The Settings Guide tool helps the clinician select from pre-set therapy ranges according to wound type and treating physician's orders. Selected ranges are a guide based on common settings for different wound types. Individual patient conditions may vary. Consult physician to verify settings for each patient.
-  Should physician orders fall outside the pre-set therapy ranges, select 'Other' in this mode or use Manual Therapy Settings detailed earlier in the Clinician section of this manual.

From the Clinician Mode Home screen, press 'Therapy', then 'Next', then 'Settings Guide', and then 'OK' to access this screen.

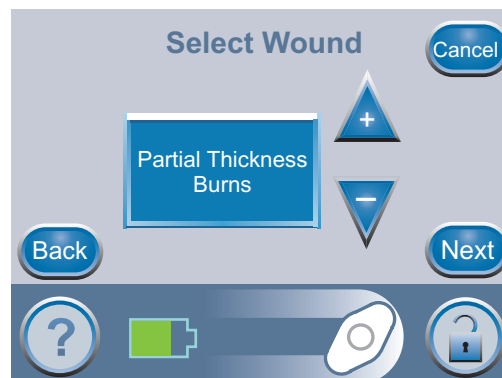

Use the  buttons to select from the available wound type selections.

Press 'Next' when finished with this screen.

## Settings Guide (cont.)



Use the  buttons to select from the available pressure selections.

Pressure selections are in ranges for the wound type selected on the previous screen.

Press '**Next**' when finished with this screen.



For wound types for which 'Intermittent' is an option, this '**Select Mode**' screen will appear.

If 'Intermittent' is not an option, the 'Confirm' screen will appear (see next page).

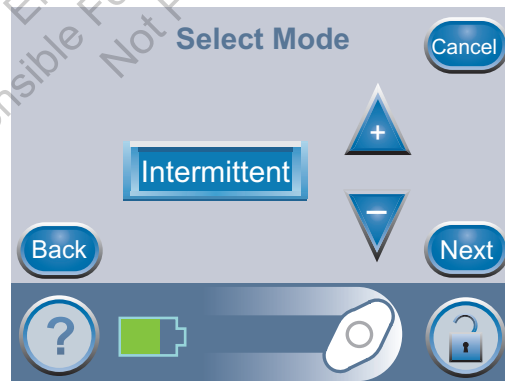



Use the  buttons to choose '**Continuous**' or '**Intermittent**' Therapy.

Press '**Next**' when finished with this screen.

## Settings Guide (cont.)

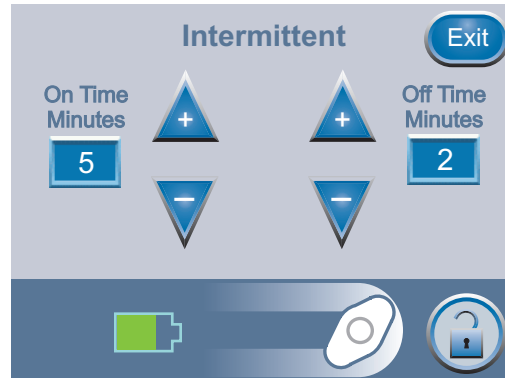
If 'Intermittent' Therapy was chosen on the previous screen, this '**Intermittent**' screen will appear.



Use the  buttons to change the desired On and Off Time (in minutes).

Both On and Off Times can be set from 1 minute to 10 minutes in 1 minute increments.

Press '**Exit**' when finished with this screen.

### Settings Guide Confirmation

 Settings take effect after '**OK**' is pressed.

Once the settings are chosen, this '**Confirm**' screen will appear.



If the displayed settings are as desired, press '**OK**' to continue to the Clinician Mode Home screen. Otherwise, press '**Back**' to change any settings that are incorrect.

 Settings Guide Intensity default is low. Intensity can only be changed using the Manual Therapy Settings.



## Starting Therapy



**WARNING:** Ensure that a new V.A.C.® Dressing was applied and therapy settings have been selected per physician's orders before starting therapy.

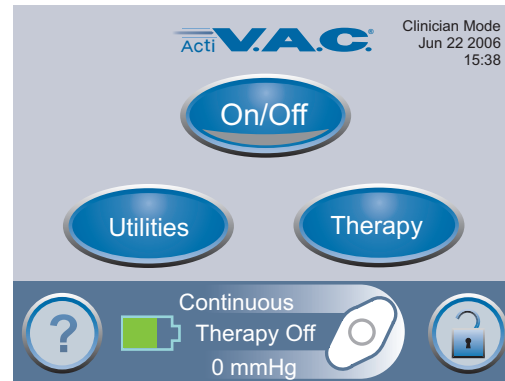

Press  to start therapy and this 'Therapy Start' screen will appear.

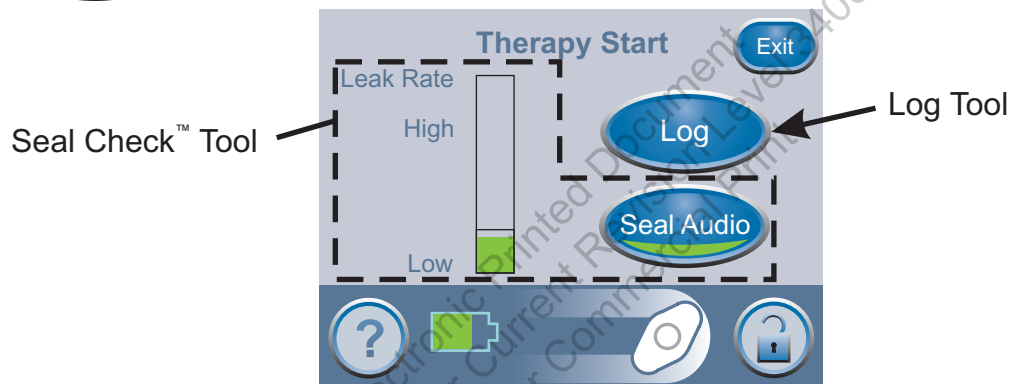

From this screen the clinician can use the 'Seal Check™' Tool to view the integrity of the V.A.C.® Dressing. The clinician can also use the 'Log' Tool to record a canister change or the number of foam pieces used during a dressing change.

### Seal Check™ Overview



Patients only have access to the Seal Check™ Tool through the 'Leak Alarm' screen when the ActiV.A.C.® Therapy Unit detects a possible leak.

- **Seal Check™** is used to help find air leaks.
- **Seal Check™** features an audible tone that speeds up or slows down as the leakage rate changes. Pressing the Seal Audio button will switch between the audible tone being On or Off.
- **Seal Check™** also features a real time bar graph that gives a visual indication of the leakage rate.

The **Seal Check™** Tool appears three (3) different ways:

1. When therapy is started from the Clinician Mode Home screen, discussed on the following pages.
2. When the **Seal Check™** button is pressed from the 'Therapy' screen.
3. When the **Seal Check™** button is pressed on the 'Leak Alarm' screen after the ActiV.A.C.® Therapy Unit detects a possible leak.

## Starting Therapy (cont.)

### How to Use Seal Check™ (When Starting Therapy)

Pressing  located on the Clinician Mode Home screen will immediately display this 'Therapy Start' screen.

Orange bar graph indicates a significant leak.

Green bar graph indicates that the ActiV.A.C.® Therapy System is operating normally.

Line on bar graph is the transition point from green to orange and vice-versa.

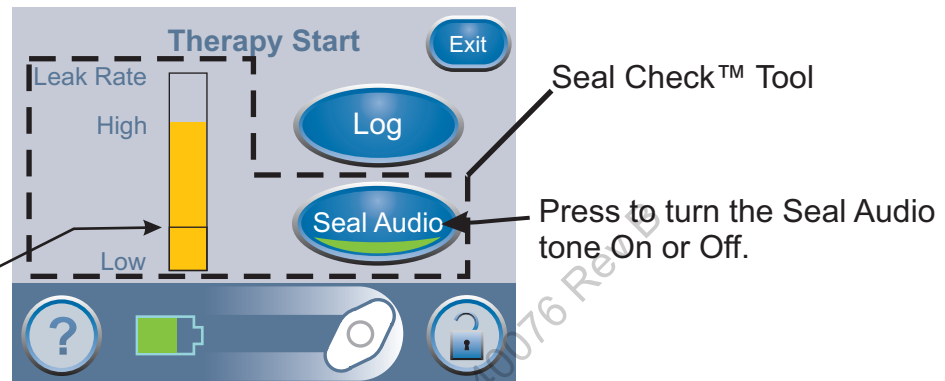

The **Seal Check™** feature provides an audible tone and a bar graph to assist in finding leaks.

- The frequency of the audible tone and the height of the bar graph will reflect the leak rate.
- The audible tone slows down and the bar graph decreases in height as the leak is found.

 During initial dressing draw down, the bar graph should turn orange and then return to a green state if there are no significant leaks.

 Most leaks occur:

- where the drape meets the skin.
- where the SensaT.R.A.C.® Pad is attached to the drape.
- at tubing connections.

### Finding the Leak Using Seal Check™

1. Ensure connector between dressing tubing and canister tubing is properly locked.
2. Ensure the canister is securely installed on the therapy unit. If the canister is properly installed, the canister cannot be removed by gently pulling the canister directly away from the unit
3. While therapy is on and using light pressure, move your hand and fingers slowly around the edges of the drape and the SensaT.R.A.C.® Pad. The bar graph will lower and the audible tone (if **Seal Audio** is on) will slow down when the leak is found.
4. Refer to the **Application Instructions** provided with V.A.C.® Dressings for information on using excess V.A.C.® Drape material to seal the leak area.

When finished with this screen, press '**Exit**' to return to the Clinician Mode Home screen.

## Starting Therapy (cont.)

### Log Tool Overview

- Log Tool can be used to record the number of foam pieces used during a dressing change.
- Log Tool can be used to record canister changes.
- Logged information is viewable and exportable on the Therapy History screens.

### How to Use Log Tool (When Starting Therapy)

Press **Log** on the 'Therapy Start' screen to access this 'Item to Log' screen.

Choose 'Canister' or 'Dressing'.

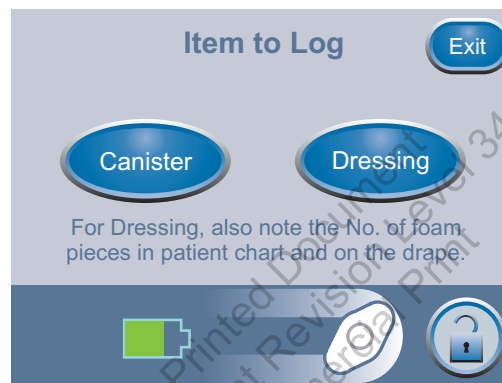

Press 'Exit' to return to the Clinician Mode Home screen.

Press **Canister** to access this 'Canister Replaced' screen.

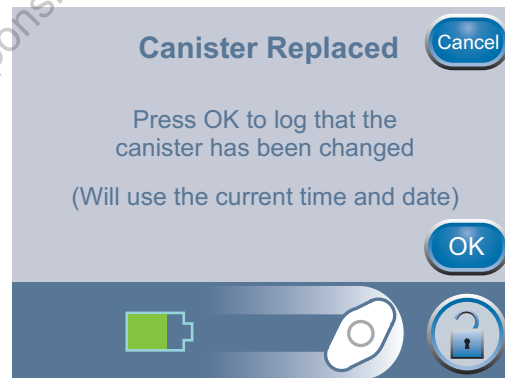

Press 'OK' to log that the canister has been replaced and return to the 'Item to Log' screen. The current time and date will be recorded.

Press 'Cancel' to return to the 'Item to Log' screen without logging an entry.

**Starting Therapy (cont.)**

Press **Dressing** to access this **'Foam Pieces'** screen.

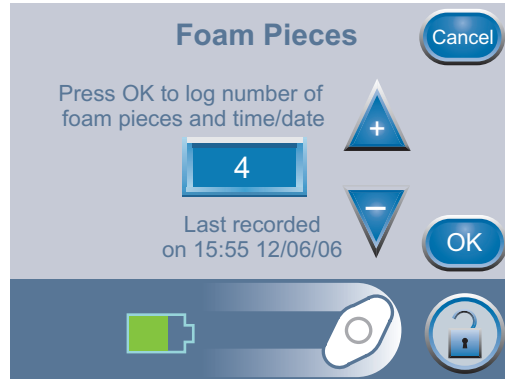

**i** Information displayed represents the last logged entry.

Use the  buttons to change the number of pieces of foam used during the current dressing change.

Press **'OK'** to log the number of foam pieces used and return to the 'Item to Log' screen. The current time and date will be recorded.

Press **'Cancel'** to return to the 'Item to Log' screen without logging an entry.



**Always document the number of foam pieces used in patient chart and on the V.A.C.<sup>®</sup> Drape.**



Logged information will appear in Therapy History as follows:

dd/mm/yy	Time	Event
12/06/06	15:54	Canister Changed
12/06/06	15:55	Dressing Changed, 4

Where the numeral after "Dressing Changed" is the number of foam pieces recorded on the above screen.

## View or Export Therapy History



Therapy History is a chronological log with dates and times for therapy starts/stops, therapy settings, alarm occurrences, and canister/dressing changes. Data can be reviewed on-screen or transferred from the ActiV.A.C.® Therapy Unit electronically in the form of a Therapy History Report.

Starting from the Clinician Mode Home screen, press **'Therapy'**, then **'Next'** then **'History'** to access this screen.



The **'Therapy History'** screen has two options:

- **'View History'**: View Therapy History on screen.
- **'Export History'**: Access to screens where the Therapy History Report can be transferred via USB or IR (Infrared).

### View Therapy History

Press the **'View History'** button on the **'Therapy History'** screen to access this on-screen therapy history display.



Use the  buttons to scroll through the Therapy History Report.



Holding these buttons  will rapidly scroll through the Therapy History Report.

Press **'Exit'** to return to the **'Therapy History'** screen.

## Export Therapy History Report



NOTICE: This data is protected by copyright law and is likely to be confidential. It is intended only for use by or for KCI or clinicians using KCI products. This data is not directly associated with a particular patient. Since this data can be altered if transferred to a different media, the data may only be considered original when downloaded directly from the ActiV.A.C.® unit.



To access the USB or Infrared Data Ports, the ActiV.A.C.® Therapy Unit must be removed from the Carrying Case.

Press the '**Export History**' button on the '**Therapy History**' screen to access this screen.



**The USB Data Port is to be used with non-powered memory sticks and drives only. No AC or battery powered drives, computers, computer equipment, or other devices may be used.**

Press '**Export to USB**' to use USB transfer. Follow screen directions.

Press '**Export to IR**' to use IR (Infrared) transfer. Follow screen directions.

Press '**Exit**' to return to the '**Therapy History**' screen.

## Troubleshooting USB or Infrared Export Problems

### USB:

- Ensure that the USB flash drive (memory stick) being used is USB 2.0 compatible.
- Ensure that the flash drive is fully plugged into the therapy unit. It may be necessary to unplug and re-plug the flash drive into the therapy unit.
- Try using a different USB flash drive.
- Remove the flash drive. Press  to power the unit off and then on. Retry exporting Therapy History.
- If the above steps do not resolve the problem, contact KCI. See back cover of this User Manual for country specific contact information.

### Infrared:

- Ensure that the Infrared Data Port on the receiving device is turned on and is in the receiving mode.
- Ensure that the two Infrared Data Ports are properly aligned (pointed directly at each other) and are within 1 meter (3 feet) of each other.
- Ensure that the lenses of the Infrared Data Ports are clean, not significantly scratched or damaged.
- Press  to power the unit off and then on. Retry exporting Therapy History.
- If the above steps do not resolve the problem, contact KCI. See back cover of this User Manual for country specific contact information.

## Clinician Help Menu

 To access the Clinician Help Menu, the unit must be in Clinician Mode.

### Changing to Patient or Clinician Mode

Press  to access the 'Help Menu'.

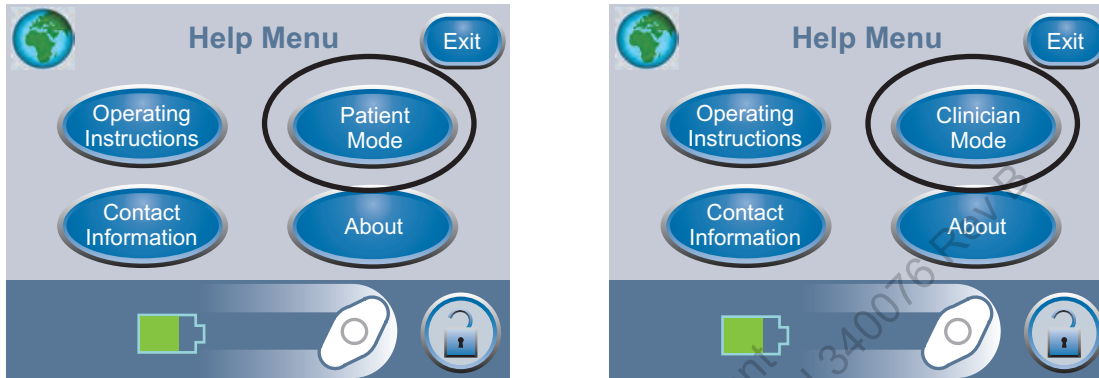

Press '**Patient Mode**' to go to 'Patient Mode'. Press '**Clinician Mode**' to go to 'Clinician Mode'.

One of these confirmation screens will appear, depending on which mode is being accessed.

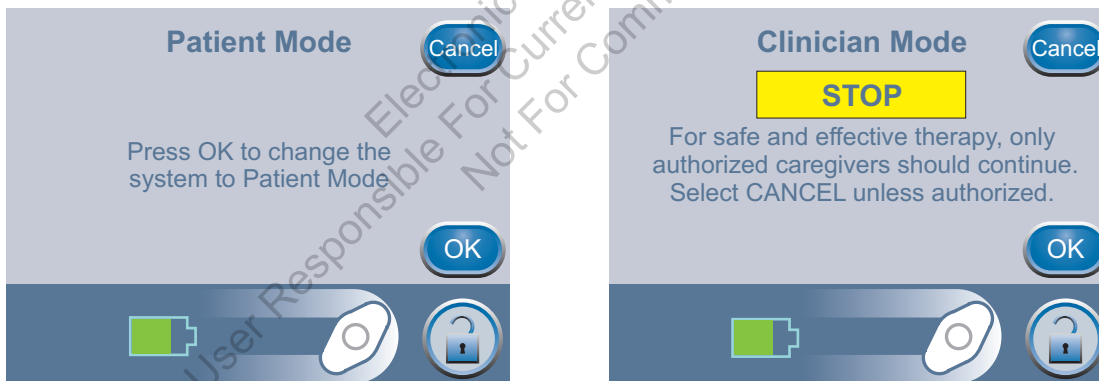

**Only authorized caregivers should access Clinician Mode. Select Cancel unless authorized.**



**WARNING: Patients should not attempt to perform a change of settings and/or therapy application without the express permission of the treating physician and/or under the supervision of a trained clinical caregiver.**

Press '**OK**' to proceed to '**Patient Mode**'. Press and hold '**OK**' for at least 5 seconds to proceed to '**Clinician Mode**'.

Press '**Cancel**' to return to the respective **Help Menu** screen.



How to access On-screen Operating Instructions and Changing Languages are in the Help Menu section of this manual.

## Clinician Utilities

From the Clinician Mode Home screen, press **'Utilities'** to access this screen.

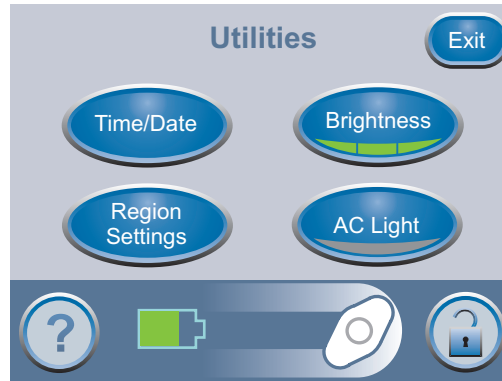

From this **'Utilities'** screen the clinician can:

- Select **'Time/Date'** to set the 'Time/Date' to current time and calendar date.
- Select **'Region Settings'** to set the displayed **'Pressure Unit'** and set the **'Date Format'**.
- Set the display **'Brightness'** of the Touch Screen User Interface.
- Turn the **'AC Light'** On and Off.



Press **'Exit'** to return to the Clinician Home screen.

### Changing Time and Date

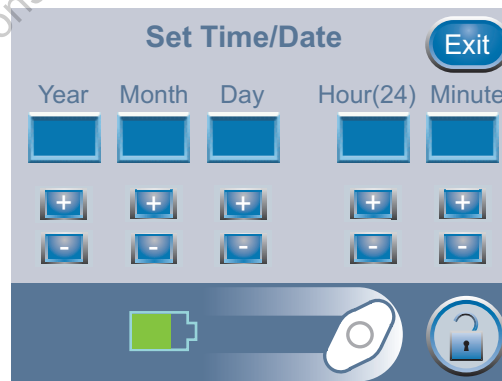
From the Clinician Mode Home screen, press **'Utilities'** then press **'Time/Date'** to access this screen.



Use the  buttons to set current time and calendar date.

 Holding these buttons  will rapidly scroll through available selections.

Press **'Exit'** to return to the **'Utilities'** screen.



## Clinician Utilities (cont.)

### Changing Pressure Units and Date Format

From the Clinician Mode Home screen, press **'Utilities'** then press **'Region Settings'** to access this screen.

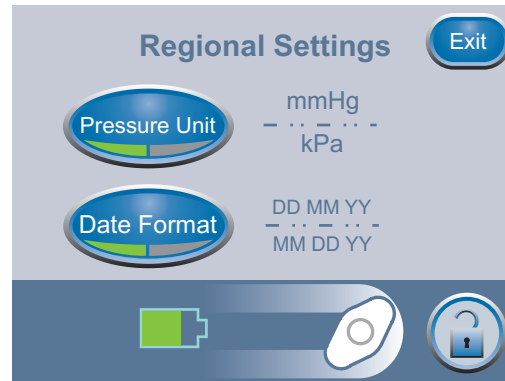

Pressing **'Pressure Unit'** switches between mmHg (millimeters of Mercury) and kPa (kilo-Pascals) units of measurement.

Pressing **'Date Format'** switches between displaying DD.MM.YY (Day-Month-Year) and MM DD YY (Month-Day-Year) formats.

**i** Default settings are: mmHg and MM DD YY.

Press **'Exit'** to return to the **'Utilities'** screen.

### Changing Screen Brightness

Pressing **'Brightness'** switches between three levels of display screen brightness.

**i** Default setting is: High



High



Medium



Low

### Changing AC Light

Pressing **'AC Light'** prevents the display backlight from dimming when the unit is properly connected to the ActiV.A.C.<sup>®</sup> Power Supply.

**i** Default setting is: On



On



Off

## Alerts and Alarms



# ATTENTION:

Important Information about Alerts and Alarms

An **Alert** will be displayed on the Touch Screen User Interface when the ActiV.A.C.® Therapy Unit detects a condition that requires patient or caregiver attention.

Alerts will be accompanied by a **single** audible tone.

Press  for more information.

An **Alarm** will be displayed on the Touch Screen User Interface when the ActiV.A.C.® Therapy Unit detects a condition that **requires immediate patient or caregiver attention in order to ensure the prescribed therapy is being delivered.**

Alarms will be accompanied by a **repeating** audible tone.

Press  to silence the audible tone for 2 minutes.

Press  for more information.



If alarm conditions cannot be resolved, contact KCI. See back cover of this User Manual for country specific contact information.

### Index of Alerts and Alarms

Battery Low Alert . . . . .	41
Battery Critical Alarm . . . . .	41
Canister Full Therapy Interrupted Alarm . . . . .	42
Canister Not Engaged Alarm . . . . .	43
Leak Alarm . . . . .	44
Seal Check™ . . . . .	44
Leak Alarm Therapy Interrupted . . . . .	45
Blockage Alert . . . . .	46
Blockage Alarm Therapy Interrupted . . . . .	46
Low Pressure Alert . . . . .	47
Low Pressure Alarm Therapy Interrupted . . . . .	47
Therapy Inactive Alarm . . . . .	48
System Error Therapy Interrupted Alarm . . . . .	48
Service Timer Expired Alert . . . . .	49

## Alerts and Alarms (cont.)

### Battery Low Alert

This alert screen appears approximately two (2) hours before the battery power level is too low to support continued operation of the ActiV.A.C.® Therapy Unit.

This alert will be accompanied by a single audible tone.

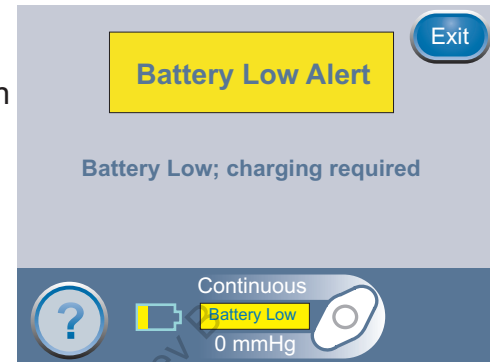

#### To resolve this alert:

1. Connect therapy unit to wall outlet using ActiV.A.C.® Power Supply to recharge battery. An **Amber** light next to the bottom-left of the Touch Screen User Interface will indicate charging is underway. Refer to the Battery Charging section of this manual for more information.
2. Press '**Exit**' on this screen to return to the 'Home Screen'.



V.A.C.® Therapy continues.

### Battery Critical Alarm



This alarm screen appears approximately thirty (30) minutes before the battery power level is too low to support continued operation of the ActiV.A.C.® Therapy Unit.

This alarm will be accompanied by a repeating audible tone.

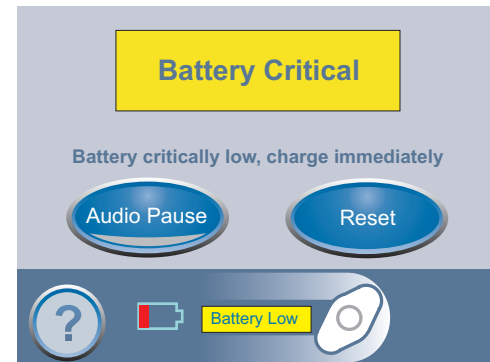
This alarm may be silenced for two (2) minutes during troubleshooting by pressing '**Audio Pause**'.



#### To resolve this alarm:

1. Connect therapy unit to wall outlet using ActiV.A.C.® Power Supply to recharge battery. An **Amber** light next to the bottom-left of the Touch Screen User Interface will indicate charging is underway. Refer to the Battery Charging section of this manual for more information.
2. Press '**Reset**' on this screen to return to the 'Home Screen'.
3. Ensure therapy is on by confirming that the green crescent is lit on the  button. If not, press  to restart therapy.



**WARNING:** Under clinician supervision, replace V.A.C.® Dressing with alternate dressing if therapy is interrupted for more than two hours.



V.A.C.® Therapy continues; however, if this alarm is not resolved within thirty (30) minutes, therapy will be interrupted.

## Alerts and Alarms (cont.)

## Canister Full Therapy Interrupted Alarm



This alarm screen appears when the ActiV.A.C.<sup>®</sup> Therapy Unit detects that the canister is full and should be replaced.

This alarm will be accompanied by a repeating audible tone.

This alarm may be silenced for two (2) minutes during troubleshooting by pressing '**Audio Pause**'.

**To resolve this alarm:**

1. Check fluid level of canister by holding the therapy unit so that the Graduated Marks on the canister are level and parallel to the floor.

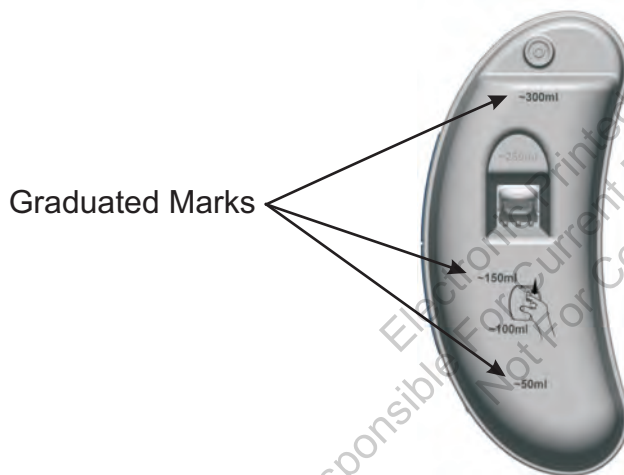

**i** A full canister is approximately 300 ml.

2. If canister is not full, press "Cancel".
3. If canister is full, change canister and press '**Reset**' on this screen to return to the 'Home Screen'. See the **Canister Change** section of this manual for additional information.
4. Restart therapy by pressing .

**!** **WARNING:** Under clinician supervision, replace V.A.C.<sup>®</sup> Dressing with alternate dressing if therapy is interrupted for more than two hours.

## Alerts and Alarms (cont.)

### Canister Not Engaged Alarm

This alarm screen appears when the ActiV.A.C.® Therapy Unit detects that the canister is not fully seated and properly latched.

This alarm will be accompanied by a repeating audible tone.

This alarm may be silenced for two (2) minutes during troubleshooting by pressing 'Audio Pause'.

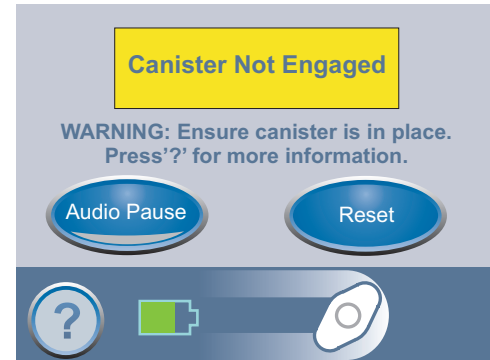

#### To resolve this alarm:

1. Remove the canister by pressing the Canister Latch Release on the canister.
2. Inspect the canister and ActiV.A.C.® Therapy Unit to ensure no foreign objects or debris interfere with the canister and therapy unit's mating surfaces.
3. Ensure both Silicone Seals and both Canister Stabilization Bumpers are present.



Silicone Seals

If Silicone Seals or Canister Stabilization Bumpers are missing or damaged, contact KCI. See back cover of this User Manual for country specific contact information.

Canister Stabilization Bumpers

4. Re-attach the canister to the ActiV.A.C.® Therapy Unit ensuring that the canister is fully engaged and latched. An audible "click" should be heard when canister is properly installed.
5. Press '**Reset**' on this screen to return to the 'Home Screen'.
6. Restart therapy by pressing .
7. If this alarm continues to appear, repeat steps 1 through 6 with a new canister. If alarm condition cannot be resolved, contact KCI. See back cover of this User Manual for country specific contact information.



**WARNING:** Under clinician supervision, replace V.A.C.® Dressing with alternate dressing if therapy is interrupted for more than two hours.

## Alerts and Alarms (cont.)

### Leak Alarm

Flashing **green** oval

This alarm screen appears when the ActiV.A.C.® Therapy Unit detects a significant air leak.

If this alarm is not resolved in three (3) minutes, therapy will be interrupted.

This alarm will be accompanied by a repeating audible tone.

This alarm may be silenced for two (2) minutes during troubleshooting by pressing **'Audio Pause'**.

**i** If this alarm is resolved within 3 minutes without using the Seal Check™ Tool, the ActiV.A.C.® Therapy Unit will automatically reset and the 'Home' screen will be displayed. Pressing **'Reset'** on this screen to return to the 'Home' screen.

#### To resolve this alarm:

1. Ensure connector between dressing tubing and canister tubing is properly locked.
2. Ensure canister is fully engaged. (See Canister Not Engaged Alarm.)
3. Press to use the **Seal Check™** Tool to help identify leaks in dressing.

**i** The patient's only access to the Seal Check™ Tool is through this Leak Alarm screen.

### Seal Check™

The **Seal Check™** feature provides an audible tone and bar graph to assist in finding leaks.

- The frequency of the audible tone and the height of the bar graph will reflect the leak rate.
- The audible tone frequency slows down and the bar graph decreases in height as the leak is found.

- Orange bar graph indicates a significant leak.
- Green bar graph indicates that the ActiV.A.C.® Therapy System is operating normally.

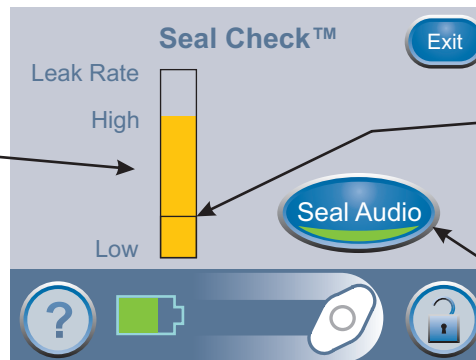

Line on bar graph is the transition point from green to orange and vice-versa.

Press to turn the Seal Audio tone on or Off.



### Finding the Leak

Most leaks occur:

- i**
  - where the drape meets the skin.
  - where the SensaT.R.A.C.® Pad is attached to the drape.
  - at tubing connections.

## Alerts and Alarms (cont.)

### Leak Alarm (cont.)

4. While therapy is on and using light pressure, move your hand and fingers slowly around the edges of the drape and the SensaT.R.A.C.® Pad. The bar graph will lower and the audible tone (if **Seal Audio** is on) will slow down when the leak is found.
5. Refer to the **Dressing Application Instructions for Use** provided with V.A.C.® Dressings for information on using excess V.A.C.® Drape material to seal the leak area.
6. Once the leak is resolved using the Seal Check™ Tool, press  on the Seal Check™ screen to return to the 'Home' screen.
7. Once the leak is resolved, ensure that V.A.C.® Therapy is on by observing that the green crescent is lit on the  button and the icon is rotating on the 'Home' screen.

 If this alarm is **not** resolved within 3 minutes, the **Leak Alarm Therapy Interrupted** alarm will appear and therapy will stop.

### Leak Alarm Therapy Interrupted

This alarm screen appears when the ActiV.A.C.® Therapy Unit has detected a leak that has not been resolved and therapy has been interrupted.

This alarm will be accompanied by a repeating audible tone.

This alarm may be silenced for two (2) minutes during troubleshooting by pressing '**Audio Pause**'.



#### To resolve this alarm:

1. Press '**Reset**' on this screen to return to the '**Home Screen**'.
2. Restart therapy by pressing .

If the leak condition was not resolved, the ActiV.A.C.® Therapy Unit will take several minutes to re-identify that a leak exists before the **Leak Alarm** will reappear and provide the opportunity to continue troubleshooting a leak using the **Seal Check™** Tool.

The patient's only access to the Seal Check™ Tool is through the Leak Alarm screen.

Should the leak not be resolved within three minutes, this screen will once again appear and therapy will stop.



**WARNING: Under clinician supervision, replace V.A.C.® Dressing with alternate dressing if therapy is interrupted for more than two hours.**



If alarm condition cannot be resolved, contact KCI. See back cover of this User Manual for country specific contact information.

## Alerts and Alarms (cont.)

## Blockage Alert

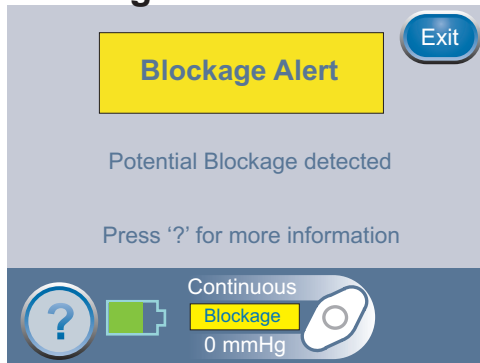

This alert screen appears when the ActiV.A.C.® Therapy Unit has detected a potential blockage and is working to determine if a Blockage Alarm needs to be displayed.

This alert will be accompanied by a single audible tone.

**To resolve this alert:**

1. Ensure both clamps on the dressing and canister tubing are open.
2. Ensure that the tubing is not kinked, crimped or blocked in any way.
3. If the Blockage Alert remains after completing steps 1 and 2, lowering the therapy unit and tubing to the same level as, or below, the wound site may resolve this alert. If the alert is cleared by lowering the unit, normal use may resume.
4. Press 'Exit' to return to the 'Home' screen.



The ActiV.A.C.® Therapy Unit continues to attempt to apply therapy.

## Blockage Alarm Therapy Interrupted

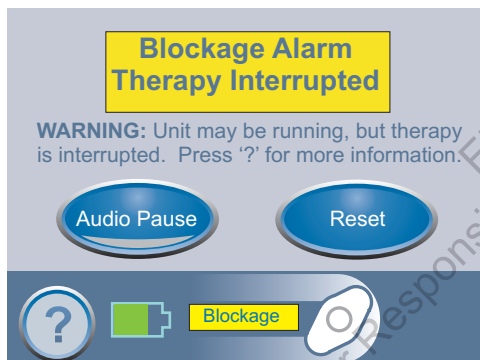

This alarm screen appears when the ActiV.A.C.® Therapy Unit has determined that a blockage is present.

This alarm will be accompanied by a repeating audible tone.

This alarm may be silenced for two (2) minutes during troubleshooting by pressing 'Audio Pause'.

**To resolve this alarm:**

1. Ensure both clamps on the dressing and canister tubing are open.
2. Ensure that the tubing is not kinked, crimped or blocked in any way.
3. If the Blockage Alarm remains after completing steps 1 and 2, lowering the therapy unit and tubing to the same level as, or below, the wound site may resolve this alert. If the alert is cleared by lowering the unit, normal use may resume.
4. Press 'Reset' on this screen to return to the 'Home Screen'.



**WARNING: Therapy unit remains on; however, negative pressure at the wound may be below set pressure, potentially compromising therapeutic benefits.**



**WARNING: Under clinician supervision, replace V.A.C.® Dressing with alternate dressing if therapy is interrupted for more than two hours.**



If alarm condition cannot be resolved, contact KCI. See back cover of this User Manual for country specific contact information.



## Alerts and Alarms (cont.)

### Low Pressure Alert

This alert screen appears when the ActiV.A.C.® Therapy Unit has not reached the selected therapy set pressure.

This alert will be accompanied by a single audible tone.

#### To resolve this alert:

1. Ensure both clamps on the dressing and canister tubing are open.
2. Ensure that the tubing is not kinked, crimped or blocked in any way.
3. If the Low Pressure Alert remains after completing steps 1 and 2, lowering the therapy unit and tubing to be level with or below the wound site may resolve this alert. If the alert is cleared by lowering the unit, normal use may resume.
4. Press **'Exit'** to return to the **'Home'** screen.



V.A.C.® Therapy, at a lower than selected pressure, is still being applied.

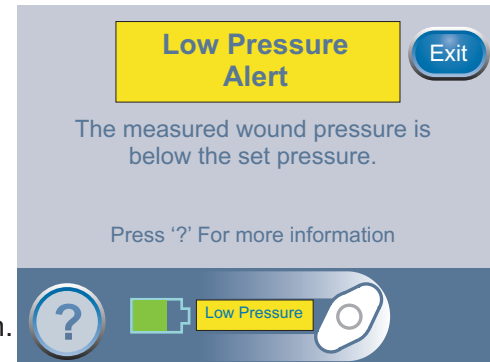

### Low Pressure Alarm Therapy Interrupted

This alarm screen appears when the ActiV.A.C.® Therapy Unit has not reached the selected therapy set pressure and negative pressure at the wound may be below set pressure, potentially compromising therapeutic benefits.

This alarm will be accompanied by a repeating audible tone.

This alarm may be silenced for two (2) minutes during troubleshooting by pressing **'Audio Pause'**.

#### To resolve this alarm:

1. Ensure both clamps on the dressing and canister tubing are open.
2. Ensure that the tubing is not kinked, crimped or blocked in any way.
3. If the Low Pressure Alarm Therapy Interrupted remains after completing steps 1 and 2, lowering the therapy unit and tubing to be level with or below the wound site may resolve this alarm. If the alert is cleared by lowering the unit, normal use may resume.
4. Press **'Reset'** on this screen to return to the **'Home Screen'**.



**WARNING: Therapy unit remains on; however, negative pressure at the wound may be below set pressure, potentially compromising therapeutic benefits.**



**WARNING: Under clinician supervision, replace V.A.C.® Dressing with alternate dressing if therapy is interrupted for more than two hours.**



If alarm condition cannot be resolved, contact KCI. See back cover of this User Manual for country specific contact information.

## Alerts and Alarms (cont.)



## Therapy Inactive Alarm

This alarm screen appears when the ActiV.A.C.® Therapy Unit has detected that V.A.C.® Therapy has been off for fifteen (15) minutes (with the unit powered on) without the Touch Screen User Interface being touched.

This alarm will be accompanied by a repeating audible tone.

This alarm may be silenced for two (2) minutes during troubleshooting by pressing 'Audio Pause'.

**To resolve this alarm:**

1. Press 'Reset' on this screen to return to the 'Home Screen'.
2. Restart therapy by pressing .
3. If V.A.C.® Therapy is not desired, turn the ActiV.A.C.® Therapy Unit off by using the **Power On/Off**  button on the front of the unit.



**WARNING: Under clinician supervision, replace V.A.C.® Dressing with alternate dressing if therapy is interrupted for more than two hours.**

## System Error Therapy Interrupted Alarm

This alarm screen appears when there is a technical fault within the ActiV.A.C.® Therapy Unit.

Several different types of system errors may occur. A number will appear in the yellow alarm box that represents the diagnostic code of the technical fault.

This alarm will be accompanied by a repeating audible tone.

This alarm may be silenced for two (2) minutes during troubleshooting by pressing 'Audio Pause'.

**To resolve this alarm:**

1. Record the error number.
2. Power the unit off and then on using the **Power On/Off**  button on the front of the unit.
3. If error persists, contact KCI. See back cover of this User Manual for country specific contact information.



**WARNING: Under clinician supervision, replace V.A.C.® Dressing with alternate dressing if therapy is interrupted for more than two hours.**

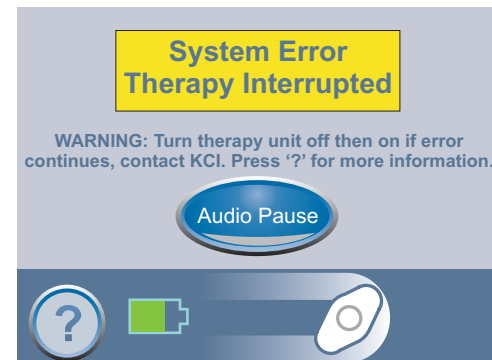

## Alerts and Alarms (cont.)

### Service Timer Expired Alert



This alert screen appears when the ActiV.A.C.® Therapy Unit has reached its service time limit.

Once the Service Timer has expired, this alert will appear every time the unit is powered up.

When 'Days Left' reaches (0) zero, this alert will reappear periodically during therapy.

#### **To resolve this alert:**

1. Contact KCI to obtain a new Service Timer code. See back cover of this User Manual for country specific contact information.
2. Press '**Enter Code**' to enter the code obtained from KCI.

Electronic Printed Document  
User Responsible For Current Revision Level 340016 Rev B  
Not For Commercial Print

## ActiV.A.C.® Frequently Asked Questions

**Q: How much does the ActiV.A.C.® Therapy Unit weigh?**

**A:** The ActiV.A.C.® Therapy Unit weighs ~1.08 kg (~2.4 lbs) with an empty canister installed.

**Q: How long does it take to charge the battery and how long will a fully charged battery last?**

**A:** It takes approximately 6 hours to fully charge the battery. The ActiV.A.C.® battery can maintain a charge up to 14 hours.

**Q. The ActiV.A.C.® Therapy Unit is sometimes noisy. Why is this?**

**A.** During normal operation it may be possible to hear the therapy unit stopping and starting (therapy on/off). This is to ensure accurate delivery of pressure.

**Q: How do I know if the ActiV.A.C.® Therapy Unit is working properly?**

**A:** The Therapy Status Bar at the bottom of the Touch Screen User Interface indicates specific therapy information. The rotating icon, also found in the Therapy Status Bar, indicates the ActiV.A.C.® Therapy Unit is applying negative pressure. Wound fluid may or may not be seen moving in the tubing.

**Q: What if I do not hear an audible click when installing a canister onto the ActiV.A.C.® Therapy Unit?**

**A:** An audible click should be heard when installing a new canister. Occasionally, you may not hear an audible click. If the canister is properly installed, the canister cannot be removed by gently pulling the canister directly away from the unit.

**Q: Is the ActiV.A.C.® Canister specific to the ActiV.A.C.® Therapy Unit?**

**A:** Yes, the 300 ml canister is specifically designed to be used with the ActiV.A.C.® Therapy Unit.

**Q: What languages are available in the ActiV.A.C.® Therapy Unit?**

**A:** When fully implemented, the therapy unit is pre-programmed with the following languages: English, Spanish, Swedish, Dutch, German, Italian, French, and Danish.



***WARNING: Languages should only be selected according to local regulatory requirements.***

**Q: Is the ActiV.A.C.® Therapy Unit allowed in flight?**

**A:** Commercial airlines will allow the ActiV.A.C.® Therapy Unit to be carried onboard with documentation from a physician, typically in the form of a doctor's prescription. The User Manual should also be available for presentation, and not in checked baggage. The label on the therapy unit and the User Manual identify the ActiV.A.C.® Therapy Unit as a medical device.

The security check point can be handled in one of two ways:

- The canister tubing and dressing tubing can be clamped and disconnected from each other. This will allow the therapy unit and canister to go through security detection in a bin, while the patient moves through the security scanner with the dressing in place.
- Alternatively, the patient can keep the dressing attached to the therapy unit, and have the security personnel hand-wand the patient and therapy device

## ActiV.A.C.® Frequently Asked Questions (cont.)

All airline rules and regulations regarding electronic equipment must be followed when traveling by air. The device should be turned off, in keeping with other electronic devices (during take off and landing). If the unit is off longer than 2 hours, the V.A.C.® Dressing should be removed and replaced with an alternate dressing.

**Q: Are there any recommendations to note when traveling?**

**A:** It is recommended that the patient travel with a fully charged battery, an alternate dressing, extra ActiV.A.C.® Canister and the User Manual. Consult your clinician prior to traveling for patient specific recommendations. A car adapter is available, for a fee, from your KCI representative.

**Q: Can the ActiV.A.C.® Therapy System be used when undergoing diagnostic procedures?**

**A:** The chart below can be used to determine whether V.A.C.® Therapy can continue during specific procedures.



**WARNING:** It is important to note that the ActiV.A.C.® Therapy Unit cannot be taken into the Magnetic Resonance Imaging (MRI) suite or the Hyperbaric Oxygen Therapy (HBO) chamber. See the V.A.C.® Therapy General Safety Information Sheet that accompanies the ActiV.A.C.® Therapy Unit for specific instructions concerning MRI and HBO therapy.



**WARNING:** Under clinician supervision, replace V.A.C.® Dressing with alternate dressing if therapy is interrupted for more than two hours.

Diagnostic Procedures	Therapy Unit Compatible	Therapy Unit <u>NOT</u> Compatible
MRI		<b>X</b>
HBO		<b>X</b>
X-Ray	<b>X</b>	
CAT Scan (CT)	<b>X</b>	
Dye Tests	<b>X</b>	
Fluoroscopy	<b>X</b>	
Ultrasound	<b>X</b>	



There is a possibility of shadow casting in the area of the wound if the V.A.C.® Dressing is left in place for the diagnostic procedures that are indicated Therapy Unit Compatible. The decision to keep the V.A.C.® Dressing in place or not should be made by the radiologist, radiology technician and/or the wound care practitioner.



**Please note:** To help provide safe and effective use, V.A.C.® Dressings are only to be used with V.A.C.® Therapy Units.

## Standard Precautions

The following are the KCI recommended daily and weekly cleaning and infection control procedures for the ActiV.A.C.<sup>®</sup> Therapy Unit.



**Always follow Standard Precautions.**

Standard Precautions are designed to reduce the risk of transmission of microorganisms from both known and unknown sources of infection. These precautions can be applied to all patients, regardless of their diagnosis or presumed infection status. Standard Precautions should be used when contact is anticipated with blood and all body fluids. This also includes secretions and excretions, except sweat, regardless of whether blood is visible or not, non-intact skin (i.e., open wounds) and mucous membranes.

### Hand Washing

Proper hand washing is the most important step in preventing the spread of infection. Follow these steps to properly wash hands:

- Wet hands with warm, running water and apply liquid or clean bar soap. Lather well.
- Rub hands together vigorously for at least 15 seconds.
- Scrub all surfaces, including the backs of hands, wrist, between fingers and under fingernails.
- Rinse well.
- Dry hands with a clean or disposable towel.
- Use a towel to turn off the faucet.

Alcohol based hand sanitizers are a good alternative when soap and water are not available. They have been shown to be more effective than soap and water in decreasing the number of bacteria and viruses. Use only 'alcohol based' products since the hand sanitizers without alcohol do not have the same effect. To properly use an alcohol based sanitizer, follow these steps:

- Apply about ½ teaspoon of the product to the palm of the hand.
- Rub hands together, covering all surfaces of the hands, until they are dry.

If hands are visibly dirty, however, wash with soap and water rather than a sanitizer.

Wash hands before and after direct contact with the patient. When using gloves, wash hands immediately after gloves are removed, between patient contacts and when necessary to avoid transfer of microorganisms to other patients or environments. It may be necessary to wash hands between tasks and procedures on the same patient to prevent cross-contamination of different body sites.

### Gloves

Wear medical gloves when touching blood, body fluids, secretions, excretions and contaminated items. Medical gloves may be clean and non-sterile, latex or latex-free. Put clean gloves on just before touching moist areas, such as mucous membranes and non-intact skin. Change gloves between tasks and procedures on the same patient when gloves become contaminated or soiled. Remove gloves promptly after use, before touching non-contaminated items and environmental surfaces. Gloves do not provide complete protection against hand contamination. Hands should be washed immediately after completed tasks or procedures to avoid transfer of microorganisms to other people or environments.

### Mask, Eye Protection, Face Shield

Wear a mask and eye protection or a face shield to protect the mucous membranes of the eyes, nose and mouth during procedures, and patient care activities that are likely to generate splashes or sprays of blood, body fluids, secretions and excretions.

## Standard Precautions (cont.)

### Gown

Wear a gown (a clean, non-sterile gown is adequate) to protect skin and to prevent soiling of clothing during procedures and patient care activities that are likely to generate splashes or sprays of blood, body fluids, secretions or excretions. Select a gown that is appropriate for the activity and amount of fluid likely to be encountered. Remove a soiled gown as promptly as possible, and wash hands to avoid transfer of microorganisms to other people or environments.

### Patient Care Equipment

Handle used patient care equipment soiled with blood, body fluids, secretions and excretions in a manner that prevents skin and mucous membrane exposures, contamination of clothing and transfer of microorganisms to other patients or environments.

### Linen

Handle, transport and process used linen soiled with blood, body fluids, secretions and excretions in a manner that prevents skin and mucous membrane exposures and contamination of clothing and that avoids transfer of microorganisms to other people, patients and environments.

### Waste Disposal

Discard all disposable items (all tubing, connectors, clamps, used canister, used dressings, etc.) in accordance with local medical waste disposal regulations.

## Care and Cleaning

### Cleaning the Touch Screen User Interface

- Lock the Touch Screen User Interface by pressing . Follow on screen instructions to unlock.
- Do not use any liquid to clean the Touch Screen User Interface.
- Use a soft, non-abrasive cloth to *gently* clean the Touch Screen User Interface. Pressing too hard may damage the Touch Screen User Interface.

### Daily Care and Cleaning

Perform a visual inspection of the unit. Check for any sign of contamination and ensure that the unit is functioning properly. If there are signs of contamination or the unit appears dirty, follow the Weekly Care and Cleaning instructions below.

If the unit is not operating properly refer to the **Alerts and Alarms** section of this manual or contact your healthcare provider or KCI.



Avoid spilling liquid on any part of the ActiV.A.C.<sup>®</sup> Therapy Unit. Liquids remaining on electronic controls can cause corrosion which can cause the electronic components to fail. Component failure may cause the ActiV.A.C.<sup>®</sup> Therapy Unit to operate erratically, possibly causing a potential hazard to patient or care providers.



Particular care must be taken when handling undiluted chlorine bleach, including proper shielding of eyes. Always mix solution by adding the concentrated chlorine bleach to the water.

### Weekly Care and Cleaning

To help reduce risk of infection and contact with blood and body fluids wear protective equipment when cleaning the ActiV.A.C.<sup>®</sup> Therapy Unit.

At least once per week, the ActiV.A.C.<sup>®</sup> Therapy Unit should be wiped with a diluted solution of 5 milliliters bleach in 1 liter (1 teaspoon bleach in 1 quart) of warm water. Use a soft cloth and wring out excess solution until the cloth is damp and not dripping. Other cleaning solutions should not be used as they may damage the ActiV.A.C.<sup>®</sup> Therapy Unit.

This page left intentionally blank

Electronic Printed Document  
User Responsible For Current Revision Level 340076 Rev B  
Not For Commercial Print



## Manufacturer Information

For additional information concerning the ActiV.A.C.<sup>®</sup> Therapy System, contact your local KCI Representative or:



### Manufacturer

**KCI USA, INC.**  
San Antonio, Texas 78219 USA  
[www.kci1.com](http://www.kci1.com)

### EC REP

**KCI Medical Products (UK), Ltd.**  
Wimborne, Dorset  
BH21 7SH  
United Kingdom  
[www.kci-medical.com](http://www.kci-medical.com)

© 2007 KCI Licensing, Inc. All Rights Reserved. All trademarks designated herein are property of KCI Licensing, Inc, its affiliates and licensors. Those KCI trademarks designated with the "®" symbol are registered and those designated with "TM" are considered to be proprietary trademarks or are pending trademark applications in at least one country where this product/work is commercialized. Most KCI products referred to herein are subject to patents or patent applications.



Electronically Printed Document  
User Responsible For Content Revision  
Not For Commercial Printing  
076 Rev B

## Explanation of Symbols Used



Warning or Caution statement of possible hazard to system, patient or staff



Important Operational Information



Caution: Consult Accompanying Documents



**WARNING:** Consult Accompanying Documents



Consult Instructions For Use



Clinician Use Only



Keep Dry



Tripping Hazard



No Bathing or Showering



Power On/Off

SN

Serial Number



Date of Manufacture



Manufacturer



Approximate symbol



Temperature Limits Symbol



Authorized Representative in the European Community

IPX0

Not protected against harmful effects of water



Alternating Current



Direct Current



Class II



Type B, Applied Part



Conforms with the Waste Electrical and Electronic Equipment Directive (2002/96/EC). At the end of useful life, dispose of all waste according to local requirements, or contact your local KCI subsidiary or agent for advice.



Conforms with the Medical Device Directive (93/42/EEC) and has been subject to the conformity procedures laid down in the council directive.



Medical Equipment classified with respect to Electrical Shock, Fire and Mechanical Hazards Only in accordance with UL 60601-1 and to CAN/CSA C22.2 No. 601.1

Standards, including JIS amendment by Underwriters Laboratory Inc.



Medical Equipment classified with respect to Electrical Shock, Fire and Mechanical Hazards Only in accordance with UL 60601-1

Standards, including JIS amendment by Underwriters Laboratory Inc.

Refer to Explanation of Symbols Used if symbols appear on the product or accompanying documentation.

## Specifications\*

Dimensions:	19.3 x 15.2 x 6.4 cm (7.6" W x 6" H x 2.5" D)
Weight (with empty canister attached):	~1.08 kg (~2.4 lbs)
Pressure Options:	25 to 200 mmHg (3.3 to 26.6 kPa)
Therapy Delivery Modes:	Continuous or Intermittent
Canister Volume:	~300 ml
<b>Electrical:</b>	
Battery Run Life:	Approximately 14 hours, depending on settings.
Battery Charge Time:	Approximately 6 hours from a fully discharged state.
External Power Supply Input:	100-240VAC .72A @ 115VAC 47-63 Hz
External Power Supply Output:	12V, 3.3 A
Patient & Enclosure Leakage Current:	<100 Microamps
<b>Environmental Conditions:</b>	
Storage Conditions	
Temperature Range:	-20°C (-4°F) to 60°C (140°F)
Relative Humidity Range:	0-95% non-condensing
Operating Conditions	
Temperature Range:	5°C (41°F) to 40°C (104°F)
Relative Humidity Range:	0-95% non-condensing
Altitude Range:	0 to 4267 m (0 to 14,000 feet)
Optimum Performance:	0 to 2438 m (0 to 8,000 feet)
IEC Classification	
Medical Equipment	
Equipment not suitable for use in presence of flammable anesthetic mixture with air, oxygen or nitrous oxide.	
Type B, Applied Part	
Class II	
IPX0	

\*Specifications subject to change without notice.

## Customer Contact Information

### International

KCI Europe Holding B.V.  
The Netherlands  
T: +31 (0)20 426 0000  
F: +31 (0)20 426 0099  
E-mail: info@kci-medical.com

### Australia

KCI Medical Australia Pty. Ltd.  
T: +61 (0) 2 9630 8877  
Orders: 1300 KCI VAC (1300 524 822)  
F: +61 (0) 2 9630 8855  
Orders Fax: 1800 KCI VAC (1800 524 822)  
E-mail: postmasterAU@kci-medical.com  
Enquiries: 1800 815 529

### Austria

KCI Austria GmbH  
T: +43 (0)1 86 330  
F: +43 (0)1 86 330 6  
E-mail: austria@kci-medical.com

### Belgium

KCI Medical Belgium bvba  
T (free): 0800 73411  
T: +31 (0)30 635 58 85  
F (free): 0800 73415  
F: +31 (0)30 259 96 91  
E-mail: infoBE@kci-medical.com

### Canada

KCI Medical Canada, Inc.  
T: +1 905 565 7187  
T (free): 1 800 668 5403  
F: +1 905 565 7270  
E-mail: infocanada@kci-medical.com

### Denmark

KCI Medical ApS  
T: +45 3990 0180  
F: +45 3990 1498  
E-mail: postmasterdk@kci-medical.com

### France

KCI Medical Sarl  
T: +33 (0) 1 69 74 71 71  
T (free): 0 800 47 83 47  
F: +33 (0) 1 69 74 71 72  
E-mail: kcifrance@kci-medical.com

### Germany

KCI Medizinprodukte GmbH  
24h Hotline: 0800 783 3524  
T: +49 (0)611 33544-0  
freefax: 0800 329 3524  
F: +49 (0)611-33544-759  
E-mail: postmasterDE@kci-medical.com

### Ireland

KCI Medical Ltd.  
T: +353 (0)14659510  
T (free): 1800 333377  
F: +353 (0)14659500  
E-mail: postmastIE@kci-medical.com

### Italy

KCI Medical Srl  
T: +39 02 457 1741  
F: +39 02 457 1742 10  
E-mail: info\_italy@kci-medical.com

### Japan

KCI KK  
Tel: +81-3-3230-3854  
Fax: +81-3-3230-3856

### Latin America

KCI International  
T (free): 1 800 531 5396, extension 6335  
T: +1 210 255 6335  
F: +1 210 255 6991  
E-mail: postmasterLSA@kci-medical.com

### Middle East (Rep. Office)

KCI Medical Middle East  
T: +971 4 20 454 20  
F: +971 4 20 454 16  
E-mail: postmasterME@kci-medical.com

### Netherlands

KCI Medical B.V.  
T: +31 (0)30 635 58 85  
F: +31 (0)30 637 76 90  
E-mail: infoNL@kci-medical.com

### Norway

KCI Medical AS  
T: +47 (0) 6684 5100  
F: +47 (0) 6684 5099  
Visitor's address: Nye Vakåsvei 12NO-1395  
Hvalstad

### Singapore

KCI Medical Asia Pte. Ltd.  
T: +65 6742 6686  
F: +65 6749 6686  
E-mail: postmasterSG@kci-medical.com

### South Africa

KCI Medical South Africa (Pty.) Ltd.  
T: +27 (0)11 315 0445  
F: +27 (0)11 315 1757  
E-mail: kcisa@kci-medical.com

### Spain

KCI Clinic Spain, S. L.  
T: +34 902 100 835  
F: +34 902 200 835  
E-mail: postmastES@kci-medical.com

### Sweden

KCI Medical AB  
T: +46 (0)8 544 996 90  
F: +46 (0)8 544 996 91  
E-mail: postmasterse@kci-medical.com

### Switzerland

KCI Medical GmbH  
T: 0848 848 900  
T: +41 (0)43 455 3000  
F: 0848 848 901  
F: +41 (0)43 455 3020  
E-mail: postmasterCH@kci-medical.com

### United Kingdom

KCI Medical Ltd.  
24h Hotline: +44 (0)800 980 8880  
T: +44 (0)1865 840 600  
F: +44 (0)1865 840 626  
E-mail: ukmarket@kci-medical.com

[www.kci-medical.com](http://www.kci-medical.com)