

# **ELP-362M ELP-362M90**

## **Underwater Locator Beacon**

### **User's Manual**

May 2015  
P/N: 362-17001-M  
Rev. C



***RJE INTERNATIONAL, INC.***

RJE INTERNATIONAL, INC  
15375 Barranca Parkway Suite I-112  
Irvine, California, 92618 U.S.A.  
[www.rjeint.com](http://www.rjeint.com)

Tel: +1-949-727-9399  
Fax: +1-949-727-0070  
e-mail: [sales@rjeint.com](mailto:sales@rjeint.com)

---

## Preface

This manual describes the installation and operation of the ELP-362M: P/N ELP-362M (30 day), and the ELP-362M90: P/N ELP-362M90 (90 day) Underwater Locator Beacons, water-activated acoustic beacons designed for use on marine voyage recorders. This manual is divided into the following six sections:

- 1 Description**
- 2 Specifications**
- 3 Installation and Checkout**
- 4 Beacon Maintenance**
- 5 Return Procedures**
- 6 Warranty**

## Proprietary Information

The information, description, and illustrations in this manual are the property of RJE International, Inc. Materials may not be reproduced or disseminated without the prior written consent of RJE International, Inc.

## Changes

RJE International, Inc. reserves the right to make changes to meet new specifications at any time without incurring any obligation to modify previously installed units. This manual is provided for informational and reference purposes only and is subject to change without notice.

## Notes and Warnings

Where applicable, special notes and warnings are presented as follows:

---

**NOTE:** A reminder to check that certain criteria are met before proceeding further in a step or sequence.

---



---

**WARNING:** A reminder that dangerous consequences could result if certain recommended procedures are not followed

---

---

# Table of Contents

<b>1</b>	<b>Description</b> .....	1
	<b>External Construction</b> .....	2
	<b>Internal Construction</b> .....	3
	<b>Theory of Operation</b> .....	3
	<b>Locating the Beacon</b> .....	3
<b>2</b>	<b>Specifications</b> .....	4
	<b>General Specifications</b> .....	4
	<b>Testing Qualification Summary</b> .....	5
<b>3</b>	<b>Installation and Checkout</b> .....	6
	<b>Installation Considerations</b> .....	6
	<b>Installation Procedures</b> .....	7
	<b>Pre-Deployment Tests</b> .....	9
	<i>ATS-260M Acoustic Test Set</i> .....	9
	<i>ATS-260M Acoustic Test Set Service</i> .....	10
	<i>Alternative Battery Check</i> .....	11
<b>4</b>	<b>Beacon Maintenance</b> .....	12
	<b>Beacon Cleaning</b> .....	12
	<b>Periodic Beacon Test</b> .....	12
	<b>Beacon Maintenance Precautions</b> .....	12
	<b>Battery Maintenance</b> .....	13
	<i>Tooling Requirements</i> .....	13
	<i>Torque Requirements</i> .....	14
	<b>Beacon Disposal</b> .....	14
	<b>Beacon Storage</b> .....	14
<b>5</b>	<b>Return Procedures</b> .....	15
<b>6</b>	<b>Warranty</b> .....	16

---

## List of Figures

<i>Figure 1-1 ELP-362M90 and Mounting Bracket</i> .....	<i>1</i>
<i>Figure 1-2 ELP-362M90 Installed in Mounting Bracket</i> .....	<i>2</i>
<i>Figure 1-3 ELP-362M90 Dimensions</i> .....	<i>2</i>
<i>Figure 1-4 Locating the VDR Capsule After Water Activation</i> .....	<i>3</i>
<i>Figure 3-1 Mounting Bracket Hole Pattern</i> .....	<i>7</i>
<i>Figure 3-2 Securing the Mounting Bracket</i> .....	<i>8</i>
<i>Figure 3-3 Installing the Beacon into the Mounting Bracket</i> .....	<i>8</i>
<i>Figure 3-4 Connecting the ATS-260M Acoustic Test Set</i> .....	<i>10</i>

# 1 Description

The ELP-362M and ELP-362M90 Underwater Locator Beacons are durable, water-activated, underwater location aids. The beacons transmit an acoustic signal at 37.5 kHz once every second after activation. The acoustic output for the 30 day battery will remain above 157.0 dB for 30 days. The acoustic output for the 90 day battery will remain above 157.0 dB for 90 days.

The ELP-362M90 Underwater Locator Beacon with 90 day battery life meets the AS8045a Specifications and can be used on all new Voyage Data Recorders manufactured after July 1, 2014. The ELP-362M Underwater Locator Beacon with 30 day battery life can be used on all Voyage Data Recorders manufactured prior to July 1, 2014.

RJE International, Inc. also offers both a standard mounting bracket kit (P/N B362-05591) and a customer specific mounting bracket kit (P/N B362-08320). Either kit allows the beacon to be securely mounted (Please contact RJE International, Inc. if the standard mounting bracket does not meet your needs). The beacon and its standard mounting bracket are shown in Figure 1-1. The beacon is also shown installed in its standard mounting bracket in Figure 1-2, and a dimensional outline of the beacon is shown in Figure 1-3.

This section provides a general descriptive overview of the beacon, its theory of operation, and use.

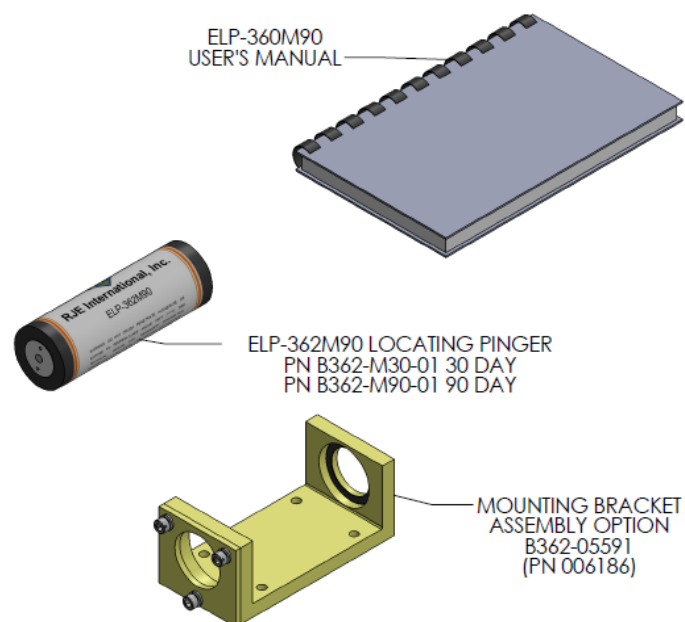

**Figure 1-1 ELP-362M90 and Mounting Bracket**

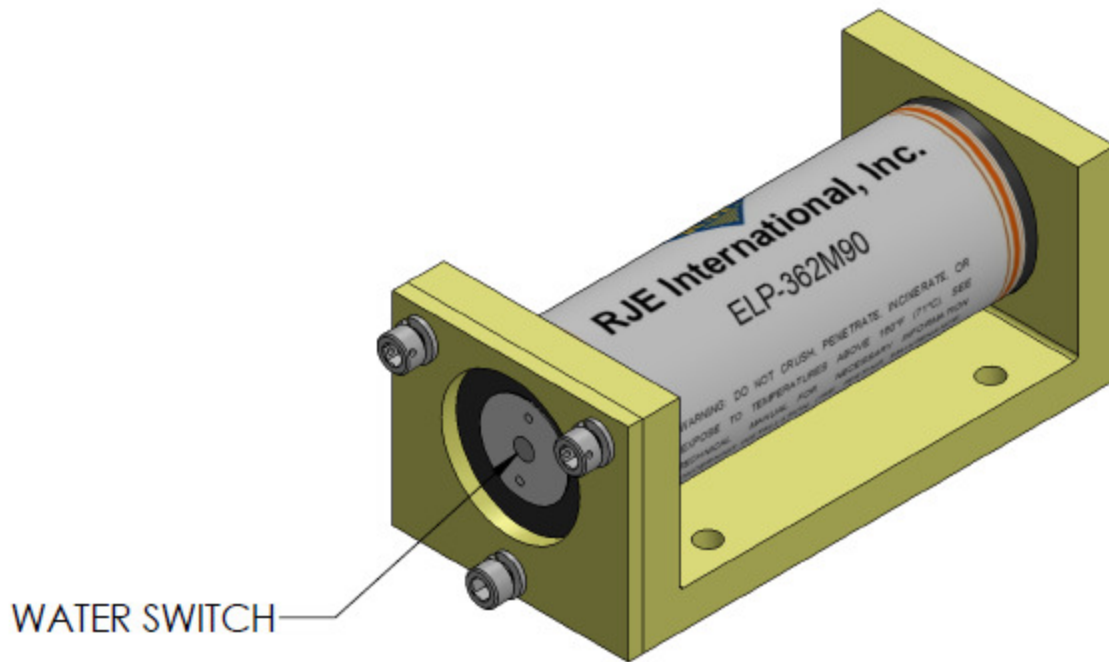

*Figure 1-2 ELP-362M90 Installed in Mounting Bracket*

## External Construction

The beacon is contained in a water-tight aluminum case capable of withstanding high-impact shock and deep-water immersion. As shown in Figure 1-2, one of the end caps has a water-activated built in switch that causes the beacon to begin transmitting when the switch comes in contact with water.

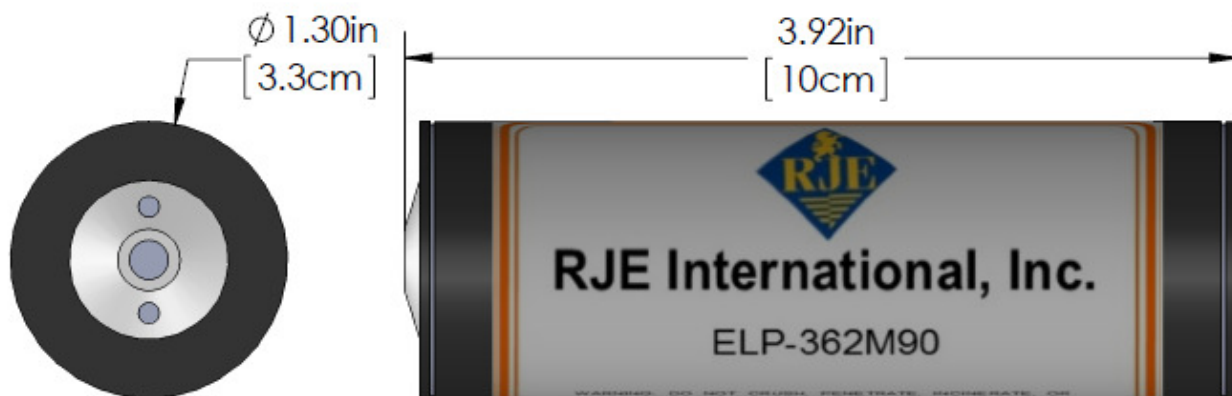

Figure 1-3 ELP-362M90 Dimensions

## Internal Construction

The major internal components of the beacon include a printed circuit board assembly, a urethane-encapsulated transducer assembly, and a battery. The battery is contained in its own, separate, user accessible compartment.

## Theory of Operation

The printed circuit board assembly generates all the necessary logic functions to produce a pulse with the desired characteristics. The pulse is then transformed from a CMOS level square wave to a much larger 37.5 kHz sinusoidal pulse by a transformer. The output of the transformer drives the urethane-encapsulated transducer, which propagates through the housing in the form of a tuned 37.5 kHz acoustic signal.

## Locating the Beacon

When the beacon is immersed in water, it will begin to radiate an acoustic signal which can be received and transformed into an audible signal by either the RJE International, Inc. APR-272 or DPL-275A Acoustic Pinger Receivers. When used in conjunction with the RJE International, Inc. Model DHA-151 Directional Hydrophone, either pinger receiver can be used as a shipboard portable receiver to determine the general vicinity of the VDR Capsule. After the area is known, a diver can be deployed with the DPL-275A, which will give the exact location of the VDR Capsule. Other equivalent pinger receivers may also be used.

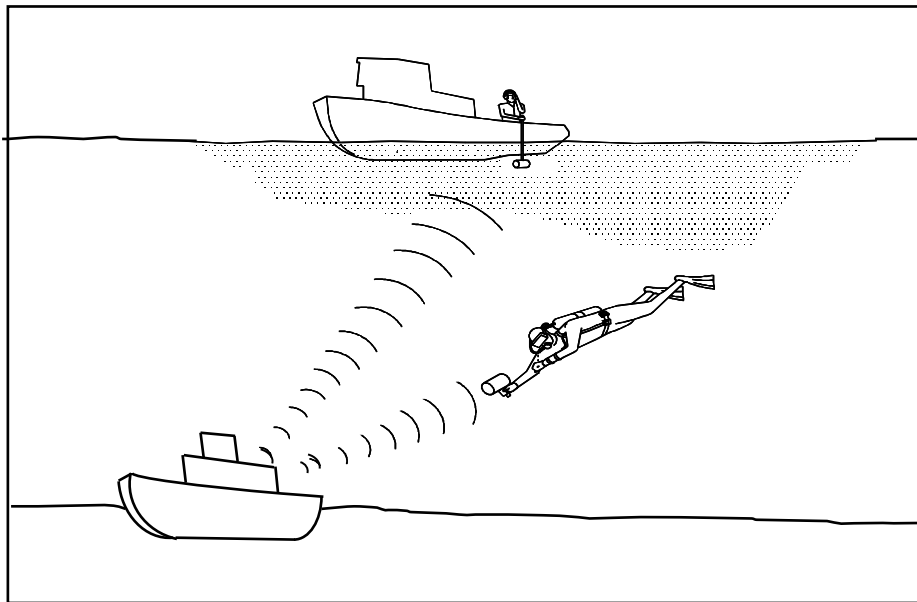

*Figure 1-4 Locating the VDR Capsule After Water Activation*

# 2 Specifications

This section provides information on the operating and environmental specifications on the ELP-362M and ELP-362M90 Underwater Locator Beacon.

## General Specifications

<u>ELP-362M</u>	<u>Specifications</u>	<u>ELP-362M90</u>
37.5 kHz, $\pm$ 1 kHz	<b>Operating Frequency:</b>	37.5 kHz, $\pm$ 1 kHz
0 to 20,000 feet (6,096 meters)	<b>Operating Depth:</b>	0 to 20,000 feet (6,096 meters)
$\geq$ 9 ms	<b>Pulse Length:</b>	$\geq$ 9 ms
P/N B362-M30-01, Incl. battery, o-ring, lube & inst.	<b>Battery Kit:</b>	P/N B362-M90-01, Incl. battery, o-ring, lube & inst.
$\geq$ 30 days	<b>Operating Life:</b>	$\geq$ 90 days
7 years from date of manufacture	<b>Battery Storage Life in Beacon:</b>	7 years from date of manufacture
$\geq$ 160.5 dB re 1 $\mu$ Pa @ 1 meter	<b>Acoustic Output:</b>	$\geq$ 160.5 dB re 1 $\mu$ Pa @ 1 meter
$\geq$ 157.0 dB re 1 $\mu$ Pa @ 1 meter	<b>Acoustic Output After 30 Days:</b>	
	<b>Acoustic Output After 90 Days:</b>	$\geq$ 157.0 dB re 1 $\mu$ Pa @ 1 meter
Fresh or salt water immersion	<b>Activation:</b>	Fresh or salt water immersion
80% sphere	<b>Beam Pattern:</b>	80% sphere
1.30 in. (3.30 cm) diameter	<b>Case Size:</b>	1.30 in. (3.30 cm) diameter
3.92 in (10 cm) long		3.92 in (10 cm) long
7075 T6 aluminum	<b>Case Material:</b>	7075 T6 aluminum
4.75 oz. (134g) Maximum	<b>Weight:</b>	5.85 oz. (165g) Maximum
-55°C (-67°F) to 71°C (160°F)	<b>Storage Temperature:</b>	-55°C (-67°F) to 71°C (160°F)
-2°C (28°F) to 38°C (100°F)	<b>Operating Temperature:</b>	-2°C (28°F) to 38°C (100°F)



## ***Testing Qualification Summary***

The beacon is designed to meet the performance specifications of AS8045a. A summary of the testing qualifications is presented in the table below.

<b>ELP-362M90 AS8045a Testing Qualification Summary</b>		
<b>Testing Conditions</b>	<b>RTCA DO-160G Section No.</b>	<b>Description of Test Conducted</b>
Altitude	4.6.1	Equipment tested to Category D2 (50,000 ft.)
Decompression	4.6.2	
Overpressure	4.6.3	
Temperature Variation	5.0	Equipment tested to category A
Vibration	8.0	Equipment tested to RTCA DO-160G Figure 8-4 Curve C (Fixed Wing) and Figure 8-2b Curve U2 (Rotary Wing)
Sand and Dust	12.0	Equipment tested to Category S
Fungus	13.0	Equipment tested to Category F
Salt Spray	14.0	Equipment tested to Category S
Magnetic Effect	15.0	Equipment tested to Category Z
Induced Signal Susceptibility	19.0	Equipment tested to category ZC
Other Tests	—	Performance, environmental and Crash Survivability Testing performed as required by AS 8045a

---

# 3 Installation and Checkout

This section encompasses the installation considerations and procedures for mounting the beacon using the mounting bracket kit, and a pre-deployment test that can be conducted using a RJE International, Inc. ATS-260M Acoustic Test set.

---

## Installation Considerations

To minimize the probability of physical damage or inadvertent activation, the following precautions should be considered when mounting the beacon:

- *The beacon should normally be mounted in according to the recorders manufacturer recommendations and should be mounted to a sturdy structure without weakening the structure itself.*
- *The beacon should be mounted in an area guarded against heavy equipment tearing loose and striking the beacon and should be mounted in a way that provides convenient access during regular inspections and tests.*
- *The beacon should be mounted in an area where sound absorbent materials are not present. Avoid affixing labels to the beacon or any other material that would affect the acoustic beam.*
- *The shelf life of the battery will be decreased when exposure to higher than normal temperatures. The maximum temperature where the beacon is mounted should not exceed 71°C (160° F).*
- *Nonconformance to the mounting instructions or intended use may void the warranty.*

## Installation Procedures

Carefully unpack the beacon and inspect it for shipping damage. If any damage is evident, it should be reported to the freight carrier and to RJE International, Inc. The mounting bracket kit includes an aluminum mounting bracket, an aluminum end plate, three drilled (for lockwire) socket head cap screws, and three lock washers.

**NOTE:** Before installing the mounting bracket, be sure that it will be possible to install and remove the beacon once the bracket is installed.

To mount the beacon, perform the following steps:

1. Refer to the mounting bracket hole pattern shown in Figure 3-1 and drill four 0.191 in (0.48 cm) diameter holes.
2. Secure the mounting bracket with four 10-32 stainless steel screws and associated hardware (not supplied) as shown in Figure 3-2.
3. Slide the beacon into the bracket as shown in Figure 3-3. Rotate the beacon until the battery date is visible and secure it in place with the end plate and the three drilled socket head cap screws.
4. Lockwire the drilled screws and clean the water activation switch (refer to section 4 Beacon Cleaning).

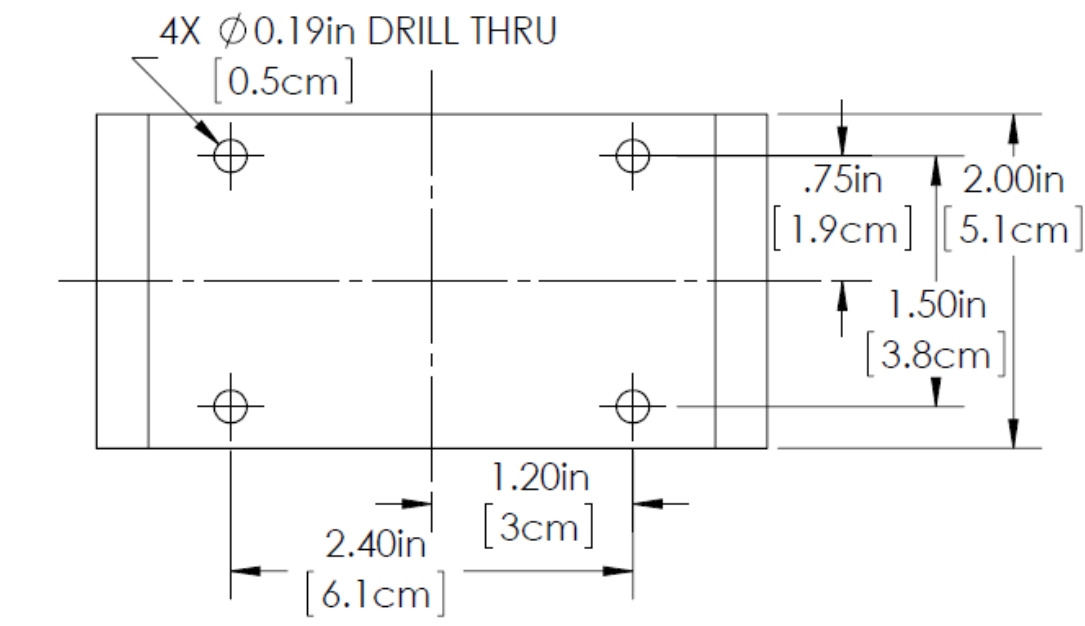

**Figure 3-1 Mounting Bracket Hole Pattern**

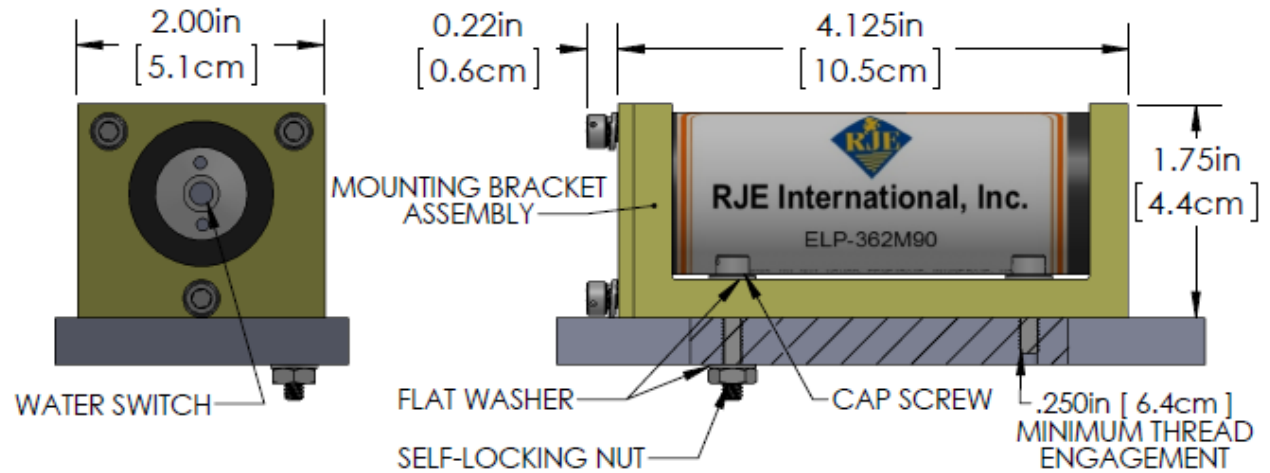

**Figure 3-2 Securing the Mounting Bracket**

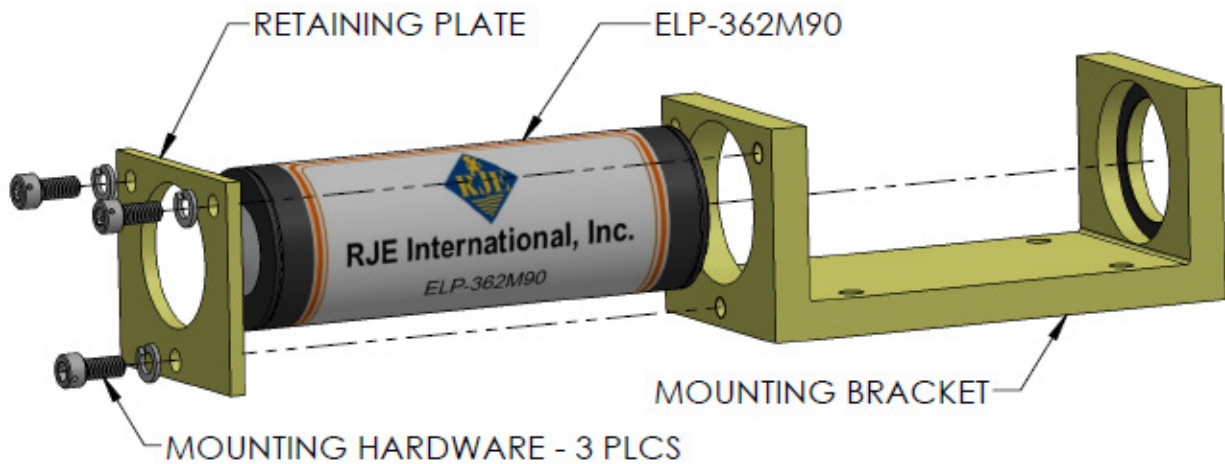

**Figure 3-3 Installing the Beacon into the Mounting Bracket**

---

## Pre-Deployment Tests

A pre-deployment test on each beacon should be performed before and after mounting using the RJE International, Inc. ATS-260M Acoustic Test Set. The test set can be used to check both the beacon's battery condition and operation. Also, an alternative method using a digital voltmeter can be used to check the beacon's battery condition.

### ***ATS-260M Acoustic Test Set***

To use the ATS-260M Acoustic Test Set to verify the battery condition and test the operations of the beacon, use the following procedure:

1. Place the test set probe on the water activation switch as shown in Figure 3-4. It is not necessary to remove the beacon from the mount to conduct the test.
2. Place the hand probe on the exposed stainless steel contact on the other end of the beacon, as shown in Figure 3-4. Do not place hand probe on anodized surface.
3. Hold down the button labeled **PUSH TO TEST** on the test set handle.
4. Check the beacon battery condition by observing the green and red indicators on the test set.

***If the green indicator is lit, the battery is good.***

***If the red indicator is lit, the battery should be replaced.  
(See Section 3 Alternate Battery Check)***

5. Check the beacon operating condition by listening for an audible tone from the test set and /or observing the amber indicator.

***If there is an audible tone and /or the amber indicator is flashing, the beacon is operating properly.***

***If there is no audible tone and the amber indicator is not flashing, the beacon is not operating properly.***

---

**NOTE:** If the beacon does not operate properly, return it RJE International, Inc. for service. (See Section 5 *Return Procedures* for instructions on how to return the beacon.)

---

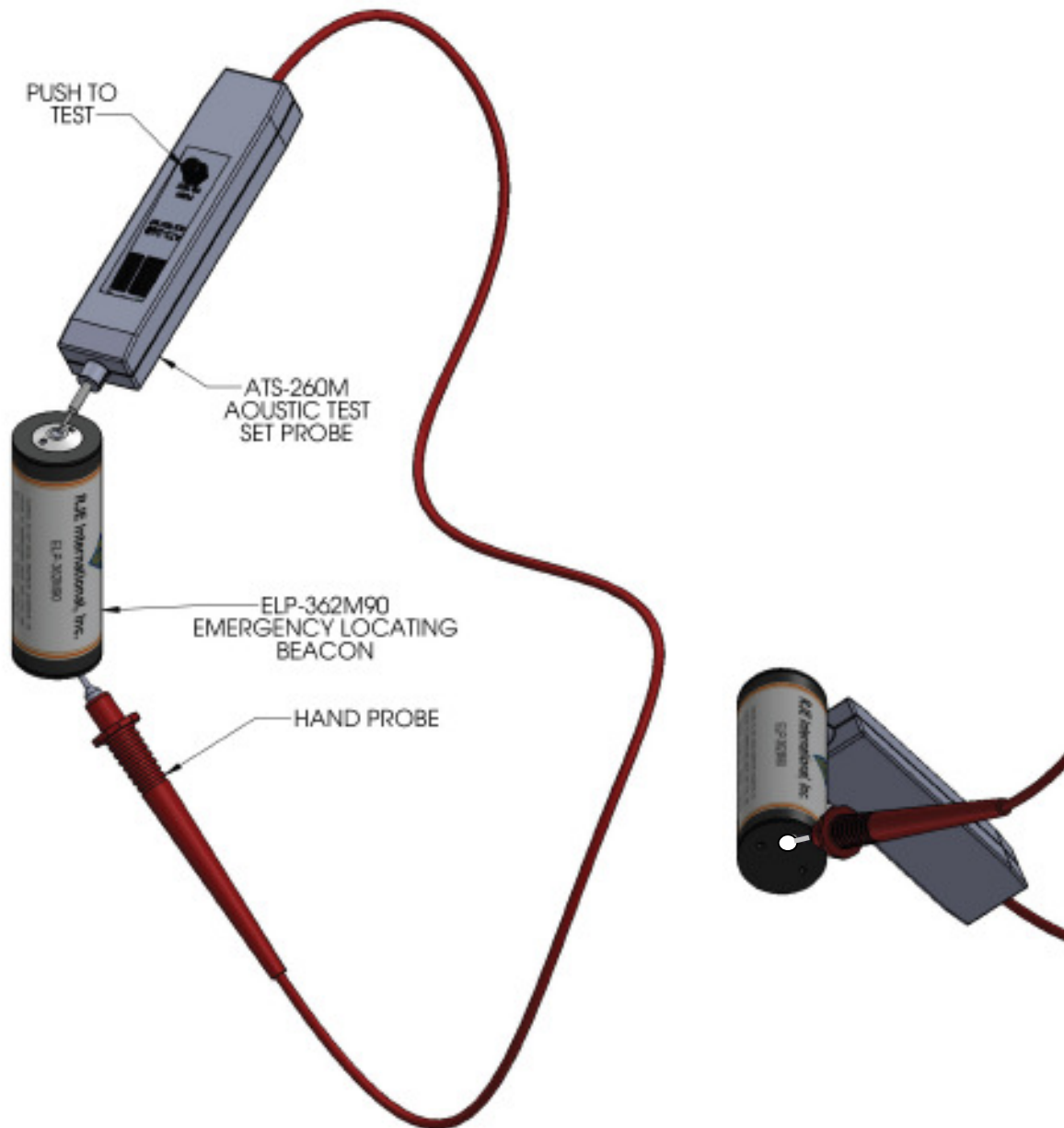

**Figure 3-4 Connecting the ATS-260M Acoustic Test Set**

### **ATS-260M Acoustic Test Set Service**

The ATS-260M Acoustic Test Set is factory calibrated at the date of manufacture. Under normal operating conditions the tester does not require re-calibration; however, should service be required, contact RJE International, Inc. (See Section 5 *Return Procedures* for instructions on how to return the test set.)

---

### ***Alternative Battery Check***

In addition to using the test set to check the beacon's battery condition, a high-impedance (minimum input impedance of 10 Megohms) digital voltmeter can be used to measure the battery voltage. Use the following procedure to measure the battery voltage:

1. Place the negative meter lead on the water activation switch.
2. Place the positive meter lead on the exposed stainless steel contact on the beacons other end. Do not place the meter lead on anodized surface.
3. Read the voltmeter.

***If the voltmeter reading is 6.0 volts or more, the beacon has sufficient operating power.***

***If the voltmeter reading is less than 6.0 volts, DO NOT remove the battery access end cap. (See Section 5 Return Procedures for instructions on how to return the beacon.)***



**WARNING:** Failure to observe these precautions could result in the release of hazardous chemicals.

---

---

# 4 Beacon Maintenance

This section covers the cleaning, recommended testing interval, disposal, storage procedures, and battery replacement for the ELP-362M and ELP-362M90 Underwater Locator Beacons.

## Beacon Cleaning

The end cap with the water switch and the end cap with the exposed stainless steel contact, should remain free and clear of dirt, grease, and dust. The end caps should be cleaned with a mild detergent and dried thoroughly with a clean cloth. This process should be repeated periodically depending on the local environment.

## Periodic Beacon Test

When the beacon is installed on a voyage data recorder, the recommended maintenance interval is the same as that of the recorder, or 12 months, whichever is shortest. Follow the *Pre-Deployment Tests* referenced in Section 3 of this User's Manual.

## Beacon Maintenance Precautions

The following precautions should be exercised when handling or storing the beacon:

- ***The beacon should not be exposed to temperatures in excess of 71°C (160°F), as the battery life can be reduced by storage in a high temperature environment.***
- ***Any situation that could possibly crush or penetrate the case of the beacon should be avoided.***



## Battery Maintenance

Replace the battery by the date stamped on the beacon label, where the three letters represent the month, and the four numbers represent the year.

*Example:* MAR2001 is March of 2001

Other date codes prior to this manual revision include the following:

1. Three letters represent the month and two numbers represent the year:

*Example:* MAR 01 is March of 2001

2. Two numbers to the left of a “/” represent the month and two numbers to the right of the “/” represent the year

*Example:* 03/01 is March of 2001



**WARNING:** Hazardous chemicals are used in the beacon battery. Dispose of the battery in accordance with local regulations.

Use the battery replacement procedure provided with the lithium battery replacement kit P/N B362-M30-01 (30 day battery) or P/N B362-M90-01 (90 day battery). Battery replacement should be performed by authorized personnel only.

### Tooling Requirements

Item	Manufacturer	Part Number
Torque Wrench	Commercially Available	-----
1/2" Socket	Commercially Available	-----
Torque Adapter	RJE International, Inc.	B362-09111
ATS-260M Test Set	RJE International, Inc.	362-00012

### *Torque Requirements*

Location	Torque
Bottom End Cap	2 to 2.5 foot pounds (2.7 to 3.4 newton meters).

## Beacon Disposal

If it is necessary to dispose of the beacon, perform the Alternative Battery Check referenced in Section 3 of this User's Manual first.

If the battery voltage is 6.0 volts or more, remove the battery and dispose of the battery and beacon in accordance with local regulations.

If the battery voltage is less than 6.0 volts, DO NOT remove the battery access end cap and dispose of the beacon in accordance with local regulations.



**WARNING:** Failure to observe these precautions could result in the release of hazardous chemicals.

---

## Beacon Storage

When long-term storage is required, the beacon should be stored in a cool, dry environment in its original shipping container.

---

# 5 Return Procedures

If you need to return an ELP-362M or an ELP-362M90 Underwater Locator Beacon for warranty service, contact RJE International, Inc. for a **Return Material Authorization (RMA)** number and shipping instructions.

**RJE International, Inc.**  
**Tel: +1-949-727-9399**  
**Fax: +1-949-727-0070**  
**e-mail: sales@rjeint.com**

You will need to provide the following information to receive a **Return Material Authorization (RMA)**:

- **Reason for return**
- **Number of beacons to be returned**
- **Serial number of each unit**
- **Shipping method, if applicable**

---

**NOTE:** Do not ship a beacon without a **Return Material Authorization**.

---

# 6 Warranty

**LIMITED WARRANTY.** RJE International, Inc. warrants that the products sold hereunder shall be free from defects in materials and workmanship under normal use and service when correctly installed, used and maintained for a period of 60 months from date of shipment from RJE International, Inc. or from an RJE International, Inc. distributor. Purchaser's receipt of any product delivered hereunder shall be an unqualified acceptance of and a waiver by Purchaser of the right of Purchaser to make a claim with respect to such product unless Purchaser gives RJE International, Inc. notice of any claim within 60 months after the receipt of such product. This warranty is limited to repair or replacement of the said product at RJE International, Inc. plant in Irvine, California, providing the product was not abused or operated other than in accordance with the RJE International, Inc. instruction manuals. RJE International, Inc. does not assume responsibility for any damage due to leakage or implosion. RJE International, Inc. reserves the right to modify its warranty at any time, in its sole discretion. THIS LIMITED WARRANTY IS NOT TRANSFERABLE.

**LIMITATION OF LIABILITY.** RJE INTERNATIONAL, INC. MAKES NO OTHER WARRANTY REGARDING ITS PRODUCTS OR THE PRODUCTS OF OTHERS EITHER EXPRESS OR IMPLIED; AND, ANY IMPLIED WARRANTY OF MERCHANTABILITY OR FITNESS FOR A PARTICULAR PURPOSE WHICH EXCEEDS THE FORGOING WARRANTIES IS HEREBY DISCLAIMED BY RJE INTERNATIONAL, INC. AND EXCLUDED FROM ANY AGREEMENT MADE BY ACCEPTANCE OF ANY ORDER. RJE INTERNATIONAL, INC. DOES NOT ACCEPT LIABILITY BEYOND THE REMEDIES SET FORTH HEREIN INCLUDING ANY LIABILITY FOR PRODUCTS NOT BEING AVAILABLE FOR USE OR FOR LOST OR CORRUPTED DATA, LOSS OF BUSINESS, LOSS OF PROFITS, LOSS OF USE OF THE PRODUCT OR ANY ASSOCIATED EQUIPMENT, COST OF CAPITAL, COST OF SUBSTITUTE OR REPLACEMENT PRODUCT, FACILITIES OR SERVICES, DOWN-TIME, CHARGES FOR PURCHASER'S TIME AND EFFORT, THE CLAIMS OF THIRD PARTIES, INJURY TO PROPERTY, OR ANY OTHER DIRECT, INDIRECT, SPECIAL, RELIANCE, INCIDENTAL OR CONSEQUENTIAL DAMAGES, REGARDLESS OF THE NATURE OF THE CLAIM AND WHETHER OR NOT FORESEEABLE AND WHETHER OR NOT BASED ON BREACH OF WARRANTY, CONTRACT OR TORT (INCLUDING NEGLIGENCE) OR STRICT LIABILITY, EVEN IF RJE INTERNATIONAL, INC. HAS BEEN ADVISED OF THE POSSIBILITY OF SUCH DAMAGES, OR FOR ANY CLAIM BY ANY THIRD PARTY EXCEPT AS EXPRESSLY PROVIDED HEREIN.

THIS LIMITATION OF LIABILITY APPLIES BOTH TO PRODUCTS AND SERVICES AND SUPPORT PROVIDED PURCHASER UNDER THIS AGREEMENT. NO ORAL OR WRITTEN INFORMATION OR ADVICE GIVEN BY RJE INTERNATIONAL, INC., ITS AGENTS OR EMPLOYEES SHALL CREATE A WARRANTY OR IN ANY WAY INCREASE THE SCOPE OF THE LIMITED WARRANTY PROVIDED ABOVE. ANY AND ALL LIABILITY OF RJE INTERNATIONAL, INC. IS EXPRESSLY LIMITED TO THE PRICE PURCHASER HAS PAID FOR THE PRODUCTS. PURCHASER'S SOLE REMEDY AGAINST RJE INTERNATIONAL, INC. IN ANY DISPUTE UNDER THIS AGREEMENT SHALL BE TO SEEK RECOVERY OF THE AMOUNTS PURCHASER PAID, PURSUANT TO THE LIMITED WARRANTY PROVIDED ABOVE, UPON THE PAYMENT OF WHICH RJE INTERNATIONAL, INC., ITS AGENTS AND EMPLOYEES, AND AFFILIATES, WILL BE RELEASED FROM AND DISCHARGED OF ALL FURTHER OBLIGATIONS AND LIABILITY TO PURCHASER.

THE LIMITED WARRANTY OF RJE INTERNATIONAL, INC. GIVES PURCHASER SPECIFIC LEGAL RIGHTS, AND PURCHASER MAY ALSO HAVE OTHER RIGHTS THAT VARY FROM STATE TO STATE. SOME STATES DO NOT ALLOW LIMITATIONS ON HOW LONG AN IMPLIED WARRANTY LASTS OR THE EXCLUSION OR LIMITATION OF INCIDENTAL OR CONSEQUENTIAL DAMAGES, SO THE ABOVE LIMITATIONS OR EXCLUSIONS MAY NOT APPLY TO PURCHASER.