

CONTENTS

I. JOINING APPLIANCES / TABLES	2
II. DATAPLATE and TECHNICAL DATA	14
III. GENERAL INSTRUCTIONS	15
IV. THE ENVIRONMENT	16
1. PACKING	16
2. USE	16
3. CLEANING	16
4. DISPOSAL	16
5. RADIO INTERFERENCE	16
V. INSTALLATION	16
1. GUIDELINES	16
2. UNPACKING	16
3. POSITIONING	16
4. CONNECTIONS	17
VI. INSTRUCTIONS FOR THE USER	17
1. COOKTOP USE (N9E/N7E)	17
2. ELECTRIC OVEN	19
VII. CLEANING	20
1. EXTERNAL PARTS	20
2. OTHER SURFACES	20
3. FILTERS	20
4. IDLEPERIODS	20
5. INTERNAL PARTS	20
VIII. MAINTENANCE	21
1. WARNINGS	21
2. TABLE OF WARNINGS	21
3. INEFFICIENCIES DETECTED DURING COOKING	21

II. DATAPLATE and TECHNICAL DATA

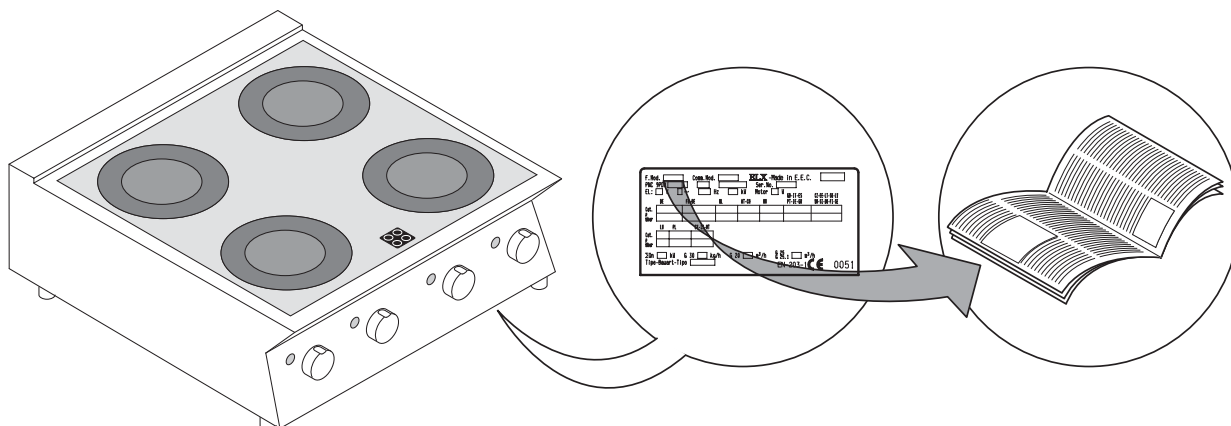

ATTENTION

This instruction manual contains information relevant to various appliances. See the dataplate located under the control panel to identify the appliance (see fig. above).

TABLE A - Infrared appliances technical data

MODELS TECHNICAL DATA		N9E			N7E				
		+9IRED2000 400mm	+9IREH4000 800mm	+9IREH400N 800mm	+7IRED2000 400mm	+7IREH4000 800mm	+7IREH40E0 800mm	+7IRED200N 400mm	+7IREH400N 800mm
Power supply voltage	V	400	400	230	400	400	230	230	230
Frequency	Hz	50/60	50/60	50/60	50/60	50/60	50/60	50/60	50/60
Phases	No.	3+N	3+N	3	3+N	3+N	3	3	3
Hotplates	No.	2	4	4	2	4	4	2	4
Cooktop hotplates	kW	6,8	13,6	13,6	4,4	8,8	8,8	4,4	8,8
Oven	kW	-	-	-	-	-	4,95	-	-
Max. total power	kW	6,8	13,6	13,6	4,4	8,8	13,75	4,4	8,8
Power supply cable section	m m ²	1,5	2,5	6	1,5	2,5	6	1,5	2,5

TABLE A - Induction appliances technical data

MODELS TECHNICAL DATA		N9E					N7E							
		+9INED2000 400mm	+9INEH4000 800mm	+9INED200N 800mm	+9INEH400N 800mm	+9INEDW00P 400mm	+7INED2000 400mm	+7INEH4000 800mm	+7INEH2F00 800mm	+7INED200N 800mm	+7INEH400N 800mm	+7INED200P 400mm	+7INEH400P 800mm	+7INEDW00P 400mm
Power supply voltage	V	400	400	230	230	400	400	800	400	230	230	400	400	400
Phases	No.	3+N	3+N	3	3	3+N	3+N	3+N	3+N	3	3	3+N	3+N	3+N
Frequency	Hz	50/60	50/60	50/60	50/60	50/60	50/60	50/60	50/60	50/60	50/60	50/60	50/60	50/60
Hotplates	No.	2	4	2	4	1	2	4	2	2	4	2	4	1
Max. total power	kW	10	20	10	20	5	7	14	10	7	14	10	20	5
Power supply cable section	m m ²	2,5	4	4	10	2,5	2,5	4	4	4	10	2,5	4	2,5

III. GENERAL INSTRUCTIONS

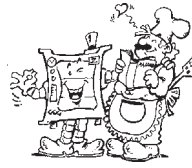

- Read the instruction manual carefully before using the appliance.

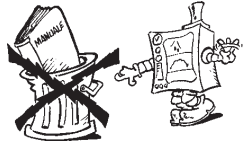

- Keep the instruction manual for future reference..



- **RISK OF FIRE** - Keep the area around the appliance free and clear of combustibles. Do not keep flammable materials in the vicinity of the appliance.





- Install the appliance in a well-ventilated place to avoid the creation of dangerous mixtures of unburnt gases in the room.
- Air recirculation must take into account the air necessary for combustion 2 m³/h/kW of gas power, as well as the well-being of persons working in the kitchen.
 - Inadequate ventilation causes asphyxia. Do not obstruct the ventilation system in the place where this appliance is installed. Do not obstruct the vents or ducts of this or other appliances.

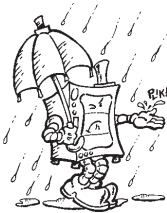

- Place emergency telephone numbers in a visible position.

- Installation, maintenance and conversion to another type of gas must only be carried out by qualified personnel authorised by the manufacturer. For assistance, contact an authorised technical centre. Demand original replacements parts.
- This appliance is designed for cooking food. It is intended for industrial use. Any use different from that indicated is **improper**.
- This appliance is not intended for use by people (including children) with limited physical, sensory or mental abilities or without experience and knowledge of it, unless they are supervised or instructed in its use by a person responsible for their safety.
- Personnel using the appliance must be **trained**. Do not leave the appliance unattended when in use.
- Turn the appliance off in case of a fault or poor operation.



- Do not use products (even if diluted) containing chlorine (sodium hypochlorite, hydrochloric or muriatic acid, etc.) to clean the appliance or the floor under it. Do not use metal implements to clean steel parts (wire brushes or Scotch Brite type scouring pads).
- Do not allow oil or grease to come into contact with plastic parts.
- Do not allow dirt, fat, food or other residuals to form deposits on the appliance.
- Do not clean the appliance with direct jets of water.
- The symbol  given on the product indicates that it should **not** be considered domestic waste, but must be correctly disposed of in order to prevent any negative consequences for the environment and the health of people. For further information regarding the recycling of this product, contact the product agent or local dealer, the after-sales service or the local body responsible for waste disposal.

Failure to observe the above can compromise the safety of the appliance. Failure to observe the above invalidates the warranty.

IV. THE ENVIRONMENT

1. PACKING



The packing materials are environmentally friendly and can be stored without risk or burned in an appropriate waste incineration plant.

Recyclable plastic components are marked with:



Polyethylene: outer wrapping, instruction booklet bag, gas nozzle bag.



Polypropylene: roof packing panels, straps.



Polystyrene foam: corner protectors.

2. USE

Our appliances offer high performance and efficiency. To reduce electricity, water or gas consumption, do not use the appliance empty or in conditions that compromise optimum efficiency (e.g. with doors or lids open, etc.); the appliance must be used in a well-ventilated place, to avoid the creation of dangerous mixtures of unburnt gases in the room.

When possible, preheat only before use.

3. CLEANING

In order to reduce the emission of pollutants into the environment, clean the appliance (externally and when necessary internally) with products that are more than 90% biodegradable (for further information refer to section V "CLEANING").

4. DISPOSAL



Do not disperse in the environment. Our appliances are manufactured using more than 90% (in weight) recyclable metals (stainless steel, iron, aluminium, galvanised sheet, copper, etc.).

Make the appliance unusable by removing the power cable and any compartment or cavity closing devices (when present) in order to avoid the risk of someone becoming trapped inside.

5. RADIO INTERFERENCE

This appliance conforms to Directive EEC 89/336 relevant to the suppression of radio interference.

V. INSTALLATION

1. GUIDELINES

Important!

The technological systems and **equipment must be installed by qualified personnel authorized to issue the certificates of conformity and compliance with current regulations.**

Important!

The equipment is marked with the induction generator frequency or frequency range in kHz.

Caution: Magnetic fields!



The symbol  on the bottom panel of the equipment indicates the presence of magnetic fields generated by the same (frequency range: 10-100 kHz).

Important!

In case of accidental breaking of the vitroceramic surface, immediately unplug the equipment.

2. UNPACKING

Remove the packing. Carefully remove the protective film from metal surfaces. Remove any traces of glue using a suitable solvent.

IMPORTANT! Immediately check for any damage caused during transport.

- Inspect the packaging materials before and after unloading.
- The forwarder is responsible for the goods during transport and delivery.
- Make a complaint to the forwarder in the event of apparent or hidden damage. Specify any damage or shortages on the dispatch note.
- The driver must sign the dispatch note: the forwarder can reject the claim if the dispatch note is not signed (the forwarder can provide the necessary form)
- For hidden damage or shortages becoming apparent only after unpacking, request the forwarder for inspection of the goods within and not later than 15 days from delivery.
- Keep all the documentation contained in the packing.

3. POSITIONING

3.1. GENERAL INFORMATION

- Handle the equipment with care in order to avoid damage or danger to persons. Use a pallet for handling and positioning.
- The installation diagram given in this instruction manual gives the appliance dimensions and the position of connections (gas, electricity, water). Check that they are available and ready for making all the necessary connections.
- The appliance can be installed separately or combined with other appliances of the same range.
- The appliances are not designed for built-in installation. Leave at least 10 cm between the appliance and side or rear non-combustible walls. Leave at least 25 cm between the appliance and side or rear walls made from combustible materials.
- Suitably insulate surfaces that are at distances less than those recommended.
- Maintain an adequate distance between the appliance and any combustible walls. Do not store or use flammable materials and liquids near the appliance.
- Leave an adequate space between the appliance and any side walls in order to enable subsequent servicing or maintenance operations.
- Check and if necessary level the appliance after positioning. Incorrect levelling of the appliance can affect combustion and cause malfunctioning.

3.2. FLOOR FIXING

To avoid accidental tipping of built-in half-module appliances installed separately, fix them to the floor carefully following the instructions enclosed with the corresponding accessory (F206136).

3.3. COMBINING APPLIANCES

- (Fig. 1A) Undo the 4 fixing screws and remove the control panels of the appliances.
- (Fig. 1B) Remove the fixing screw nearest the control panel, from each side to be joined.
- (Fig. 1D) Bring the appliances together and level them by turning the feet until the tops match.
- (Fig. 1F) From the rear of the appliances, insert the coupling plate supplied in the side housings on the back panels. Secure the plate with two flathead M5 screws provided.
- (Fig. C) Turn one of the two plates inside the appliances 180°.
- (Fig. E) From inside the control panel of the same appliance, join them at the front side, screwing one TE M5x40 screw (supplied) on the opposite insert.

NB: For appliances installed individually or for appliances at the front of an installation (where the joining plate is not used), insert the plug "T" (Fig1G) supplied, in the side housings on the back. Tighten the plug with the self-tapping screw supplied.

3.4 ASSEMBLY AND JOINING OF COUNTER TOP APPLIANCES ON BASE, OVEN, BRIDGE, CANTILEVER

Follow the instructions supplied with the optional product chosen.

IMPORTANT! INSTALLATION LIMITS Induction appliances cannot be installed on the hygienic base or hot cupboard, as this would make cooling of the components impossible, with consequent malfunctioning. In case of installation on a counter, position a baffle (A) to separate the cooling air inflow (IN) and outflow (OUT). The baffle must close the space between the bottom and the counter.

IMPORTANT! OPERATING LIMITS. Induction appliances: to guarantee continuous operation at maximum power, the room temperature must be below 40 °C.

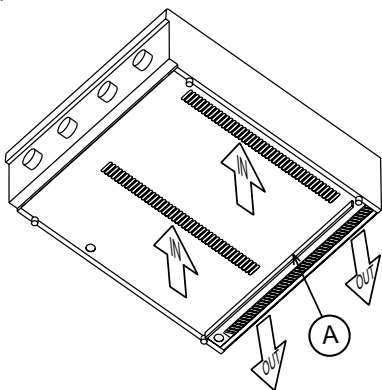

3.5 SEALING GAPS BETWEEN APPLIANCES

Follow the instructions supplied with the optional sealing paste pack.

4. CONNECTIONS

4.1. ELECTRIC APPLIANCES

4.1.1. ELECTRICAL CONNECTION (Fig. 2A-Table A)

IMPORTANT! Before making the connection, check the compatibility of the dataplate specifications with the mains voltage and frequency.

- To access the terminal board, remove the control panel of the appliance by removing the fixing screws (fig. 2A 1-2).
- Connect the power supply cable to the terminal board as shown in the wiring diagram enclosed with the appliance.
- Secure the power supply cable with the cable clamp.

IMPORTANT! The manufacturer declines any responsibility if the safety regulations are not respected.

4.1.2. POWER SUPPLY CABLE

Unless otherwise specified, our appliances do not come equipped with a power supply cable. The installer must use a flexible cable having characteristics at least equivalent to H05RN-F rubber-insulated type cables. Protect the cable section outside the appliance with a metal or rigid plastic pipe.

4.1.3. CIRCUIT BREAKER

Install a circuit breaker ahead of the appliance. Contact opening distance and maximum leakage current must comply with current regulations.

4.2. EQUIPOTENTIAL NODE AND EARTH CONNECTION

Check the conformity of the electrical system with current standards and ensure that the prescribed protection and safety devices are installed. The appliance must be earthed; it must be included in an equipotential node by means of the screw located under the appliance frame at the front right. The screw is marked with the symbol .

VI USER INSTRUCTIONS

1. COOKTOP USE (N9E/N7E)

1.1. INFRARED MODELS

The 1/2 module cooktops have two 3,4kW. (N9E)/2,2 kW (N7E). radiating zones. The 1 module cooktops have four 3,4kW. (N9E)/2,2 kW (N7E) radiating zones.

All the radiating zones have a temperature limiter that cuts off the electrical power when the temperature reaches the max. value. The limiter resets automatically. For correct use and to obtain energy-saving, observe the following:

- turn on the hotplate only after positioning the pot;
- do not leave the hotplate turned on without pots or with empty pots;
- do not allow cold liquids to spill on the hotplate when hot.

1.1.1 CHOICE OF POTS

- All types of metal containers with a smooth bottom that does not scratch the vitroceramic can be used.
- The bottom of the containers must be clean and dry before use.
- The diameter of the bottom of containers must coincide with that of the cooking zone. The optimum thickness of s/steel containers is 4 - 6 mm.
- The bottoms of containers must be perfectly flat in order to offer better energy transmission.

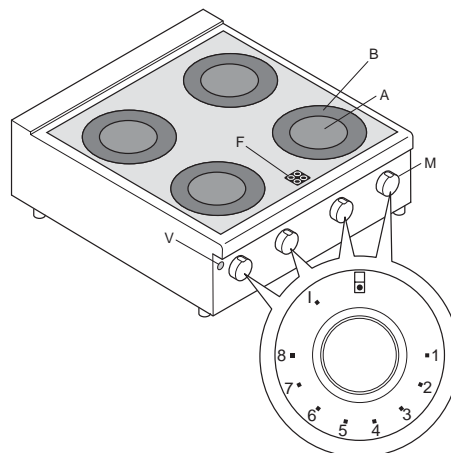

Switching on

- Turn on the switch installed ahead of the appliance.
- To turn on central zone "A" of the relevant hotplate, turn knob "M" to the desired power. The knob has the following positions:
"0": radiating zones A-B off;
"1"... "5": minimum power;
"6"... "8": medium power;
"9": maximum power.
- Lighting up of green indicator "V" signals that the power is on.
- To turn on the two concentric zones "A" and "B" of each cooking area at the same time, turn the knob to pos. "6", then turn it the other way to the desired power.
- To have only one heating zone (central area A) again, turn the knob pointer to "0" then turn it to the desired power.
- When the temperature of the radiating zone exceeds 50° C the corresponding red light "F" comes on. It goes off only when the zone temperature falls below 50° C.

Switching off

- Turn the control knobs "M" to "0".

1.2. INDUCTION MODELS

The induction appliance has 2 or 4 independent round heating zones that can be adjusted separately. The electric power of each heating zone is 5 kW.

NOTE: The induction cooking plate (in vitroceramic) is ready to use; a pre-heat phase is not necessary.

1.2.1 CHOICE OF POTS

The induction cooking system is equipped with a pot recognition system. If the pot is removed from a turned on cooking area, that area switches off automatically. When the pot is put back on the zone, the zone comes on again.

- It is advisable to use pots specially designed for induction, and in particular multilayer-type pots.
- Use pots with bottom in iron, iron plate, enamelled iron, cast iron, special multilayer metals.
- Do not use pots in layered metal with aluminium body and open edge.
- This heating system does not work with unsuitable materials; these are: nickel-chromium s/steel, aluminium, copper, brass, glass, porcelain.
- Pots of diameter less than approx. **12 cm** are not recognized by the system; heating remains off.
- It is also advisable to use pots with **MAXIMUM** diameter **28 cm** in order to obtain maximum heating efficiency.
- To avoid compromising inductor functionality, never **use pots with bottoms that are not perfectly flat**: the temperature may not be measured correctly, damaging the appliance.

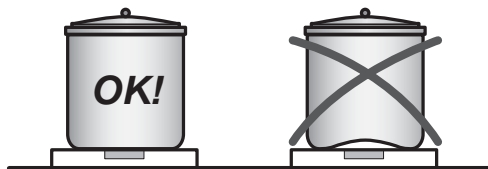

- Do not use empty pots or pans on the appliance as they can quickly reach very high temperatures.

1.2.2 OPERATION WITH KNOB

Each heating zone is controlled by a knob "M":

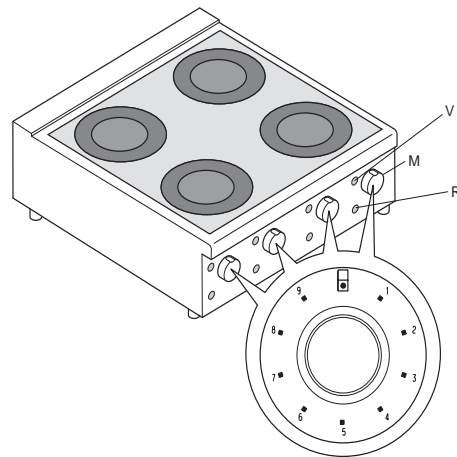

- Turn on the switch installed ahead of the appliance.
- To turn on the relevant heating zone turn knob "M" to the desired power.

The knob has the following positions:

- "0": zones off;
- "1"... "4": minimum power;
- "5"... "8": medium power;
- "9": maximum power.

When the switch is turned on and a suitable pot is positioned on the appliance, green On indicator "V" lights up. If there are no pots or an unsuitable pot on the appliance, the light flashes at 2-second intervals.

Lighting up of red lamp "R" signals a serious problem in the inductor. In this case, call the authorized technical assistant.

1.3. COOKING ADVICE

- Optimum even heating is achieved with pots properly centred on the circular serigraphy.
- Never place more than one pot on the same circular area.
- Never allow two or more pots to touch on the top when switched on.
- Induction has a very low inertia in transferring electric energy from the source to the food: if the energy value is changed the reaction on the food occurs immediately.
- Heating is very rapid: at max. power, bottoms of empty pots and pans reach approx. 200°C.
- Shifting the pot on the vitroceramic plate causes uneven conduction of heat on the bottom and therefore food sticking to a part of it: the pot must always remain in the middle of the cooking zone.
- When heating oil or fat, watch the pot constantly because these substances can quickly overheat and burn.

1.4. SAFETY INSTRUCTIONS

- **The hotplate cannot be cooled with water.** Do not allow pot contents to spill on the hotplate, for example, when filling them with water from a side pourer.
- For reasons of strength, a 6 mm thick vitroceramic top is used. In this way the appliance is suitable for normal use in industrial kitchens. There is an unavoidable residual risk of breakage due to punctiform impacts, e.g. objects falling on it.

CAUTION! Be careful when handling the pots and pans. Any excessive knocking could damage the vitroceramic top.

- If the vitroceramic plate has cracks or is broken, the induction appliance must not be turned on. This would be dangerous.
- As a result of the transmission of heat from the pot, the vitroceramic plate is very hot after every cooking process and therefore must not be touched (avoid burns).
- Due to dangers in the event of overheating, empty pots must not be heated unattended.
- Do not place paper, cardboard, cloths, etc, between the pot and the plate, because this could cause fire.
- As the transmission of heat occurs rapidly and unevenly in metal objects, no other object except pots must be placed on the cooktop. The strong heating could cause burns to personnel.
- Do not place closed tinned foods, aluminium foil, cutlery or other metal objects on the cooking zone.
- If a splashguard device is used for cooking, it must not have a metal surface.
- When using the appliances, objects such as rings and watches worn by the user can become very hot if brought near the surface of the appliance.
- Persons wearing pacemakers should see a doctor to know if their safety is guaranteed near this type of appliance.
- Do not place credit cards, telephone cards, tape cassettes or other articles that react to magnetization on the glass plate.
- The induction appliance is equipped with internal air cooling. The are intake and discharge openings must not be blocked with objects or cloths, otherwise the appliance could be damaged due to excessive overheating.
- Do not clean this appliance with jets of water.
- Repairs can only be carried out by personnel trained by the manufacturer.
- Make sure the pots do not touch and that they are always placed a certain distance from each other.

2. ELECTRIC OVEN USE

The heating elements are controlled by a 4-position selector knob "D", whereas the oven temperature is controlled by a thermostat "E".

The selector knob allows the most suitable type of heating to be chosen, switching on the heating elements in an appropriate way:

- Off position
- 1 "appliance On" position
- upper and lower heating elements
- upper heating element
- lower heating element
-

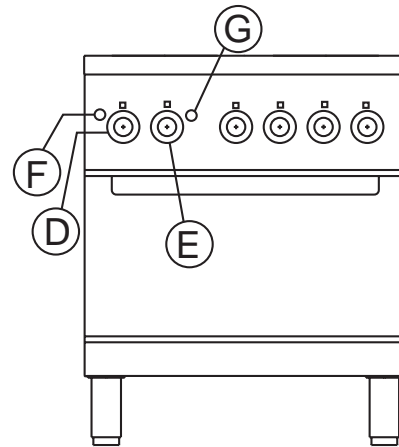

NB! The oven door must be closed for all types of cooking.

2.1. SWITCHING THE OVEN ON

Turn heating element control knob "D" to the required setting. Lighting up of green indicator "F" signals appliance power On. Turn thermostat knob "E" to the required cooking temperature (between 140 and 320 °C). Lighting up of yellow indicator "G" signals that the heating elements are on; it goes off when the set temperature is reached.

2.2. SWITCHING OFF

Turn the control knobs to the Off position "0". Turn off the electrical switch installed ahead of the appliance.

VII CLEANING

CAUTION!

Before carrying out any cleaning operation, disconnect the appliance from the electrical power supply.

Do not use flammable substances for cleaning and do not leave containers with such substances near the appliances.

1. EXTERNAL PARTS

SATIN-FINISH STEEL SURFACES (daily)

- Clean all steel surfaces: dirt can be easily removed as soon as it forms.
- Remove dirt, fat and food residuals from steel surfaces when cool, using soapy water, applied with or without detergent with a cloth or sponge. Dry the surfaces thoroughly after cleaning.
- With stubborn dirt, grease or food residuals, wipe the cloth/sponge with the grain of the satin finish and rinse often: rubbing in a circular motion combined with the particles of dirt deposited on the cloth/sponge could damage the steel's satin finish.
- Iron objects could ruin or damage the steel: damaged surfaces become dirty more easily and are more liable to corrode.
- Have the satin finish repaired if necessary.

SURFACES BLACKENED BY HEAT (when necessary)

Exposure to high temperatures can cause the formation of dark marks. These do not constitute damage and can be removed by following the instructions given in the previous paragraph.

2. OTHER SURFACES

VITROCERAMIC SURFACES

- Clean the vitroceramic top using a paper serviette soaked in a specific detergent for glass; rinse the top, then dry with a clean and dry cloth.
- Do not clean the top when hot.

Infrared:

Use a razor blade scraper (supplied) to clean the top;

- Using the scraper, immediately remove any pieces of plastic or spots of sugary food from the cooking zone: on melting due to the high temperature, these ruin the vitroceramic.

Induction

- Immediately remove any pieces of aluminium foil from the cooking zone, to avoid damaging the induction device.

3. FILTERS

AIR FILTERS

To avoid breakage and damaging the application, **check and clean the filter at least once a month**. This operation must be carried out by an authorized technician (the filter is inside the appliance).

For cleaning: remove the filter from its seat and bang it hard to clean off the dust. If the filter is dirty with grease, wash it with degreasing soap, then rinse and dry. At the end of the operation, refit the filter in its seat.

Every three months it is advisable to replace the filter if it has deteriorated.

4. IDLE PERIODS

If the appliance is not going to be used for some time, take the following precautions:

- Close any cocks or main switches installed ahead of the appliances.
- Rub all s/steel surfaces vigorously with a cloth moistened with vaseline oil in order to form a protective film.
- Periodically air the premises.
- Have the appliance checked before using it again.
- To avoid too rapid evaporation of accumulated moisture and consequent breaking of the element, when turning on again, leave electric appliances on minimum for at least 45 minutes.

5. INTERNAL PARTS (every 6 months)

IMPORTANT! Operations to be carried out exclusively by specialized technicians.

- Check the condition of internal parts.
- Remove any deposits of dirt inside the appliance.
- Check and clean the flue system.

N.B.: In certain ambient conditions (e.g. **intensive** use of the appliance, salty environment, etc.) cleaning should be more frequent.

VIII MAINTENANCE

NOTES: For that purpose, it is advisable to stipulate a maintenance contract.

1. WARNINGS

Red light on and green light flashing between two longer lighting phases requires an initial action by the user and, if necessary, a more thorough check by the after-sales service, according to the table given below.

Each cooking zone has an internal temperature control device

that is activated before any overheating, reducing the cooking zone power by 30%. If overheating persists, the cooking zone is temporarily turned off. Cooling is quicker if the pot is taken off the vitroc ceramic plate. It is advisable to turn the zone off with the control knob and wait a while. When cooled, the cooking zone can be switched on again by turning the control knob from "0" to the desired setting.

2. TABLE OF WARNINGS

No. LAMP GREEN LED	IMPORTANT	CAUSE	CORRECTIVE ACTION (USER)	CORRECTIVE ACTION (AFER-SALES SERVICE)
1	Overcurrent in hardware	Material of pot unsuitable	Use a pot made from appropriate material	-
2	Inductor not fed	Inductor not connected to generator	Disconnect the appliance from the mains and call the after-sales service	Correctly connect the inductor
3	IGBT temperature (power terminals) too high	Dirty air filters	Disconnect the appliance from the mains and call the after-sales service	Clean the air filters
		Cooling duct obstructed		Make sure the cooling air inlet and outlet are not blocked
		Ingestion of hot air from the cooling inlets		Check the cooling air path
		Cooling fan blocked or faulty		Clean or replace the cooling fan
		Temperature sensor of power terminals faulty		Replace the temperature sensor
4	Inductor temperature too high or too low	The pot is empty	Remove the pot, switch the unit off and wait until the cooking zone has cooled	-
		Inductor temperature sensor faulty	-	Replace the inductor temperature sensor
5	Control interface interruption	control interface faulty	Disconnect the appliance from the mains and call the after-sales service	Check or replace the control interface
6	Power electronics temperature too high or too low	Dirty air filters	Disconnect the appliance from the mains and call the after-sales service	Clean the air filters
		Cooling duct obstructed		Make sure the cooling air inlet and outlet are not blocked
		Ingestion of hot air from the cooling inlets		Check the cooling air path
		Cooling fan blocked or faulty		Clean or replace the cooling fan
		Power electronics temperature sensor		Replace the temperature sensor
7	Cooking zone temperature sensor	The cooking zone temperature sensor is faulty	Disconnect the appliance from the mains and call the after-sales service	Check or replace the inductor temperature sensor
8	Mains phase fault	A phase is lacking or phases not synchronised	Disconnect the appliance from the mains and call the after-sales service	Check the main power supply
9	External temperature	Temperature too high/low; faulty sensor	Disconnect the appliance from the mains and call the after-sales service	Check/replace the sensor
10	Communication error	Error on CAN-Bus or LIN line	Disconnect the appliance from the mains and call the after-sales service	Check the internal connections
		Disconnection between the generator and controls		
11	Initialisation error	Error during hardware initialisation	Disconnect the appliance from the mains and call the after-sales service	Wait for the generator to reset after 30s
12	Error in mains current	Error in mains current measurement	Disconnect the appliance from the mains and call the after-sales service	Check the main power supply
13	Error in mains voltage	Mains voltage too high or too low	Disconnect the appliance from the mains and call the after-sales service	Check the main power supply
14	Voltage error in a phase	Voltage of a phase too high or too low	Disconnect the appliance from the mains and call the after-sales service	Check the main power supply
15	Empty pot protection	Mains error	Disconnect the appliance from the mains and call the after-sales service	Disconnect the appliance, wait a few seconds and switch it on again
		Pot empty		Disconnect the appliance, remove the pot and wait a few minutes until the cooktop has cooled completely
		Coil sensor fault		Replace the sensor

3. INEFFICIENCIES DETECTED DURING COOKING

INEFFICIENCY	CAUSE	CORRECTIVE ACTION
Insufficient heating of cooking zone	Material of pot unsuitable	Use a pot made from appropriate material
	A mains phase is lacking	Check the mains connections
Continuous heating of cooking zone at max. power	Control interface faulty	Check or replace the control interface
A free cooking zone starts working	Pot detection sensor faulty	Repair or replace the generator
Small metal objects are heated	Pot detection sensor faulty	Repair or replace the generator
No heating of cooking zone	Pot bottom less than 12 cm wide	Use a pot of suitable size
	A phase is lacking	Check the mains connections
The appliance does not respond	Main fuse blown	Check the mains connections
	Supply line faulty	
The fuses blow when switching the appliance on	Short circuit in generator	Repair or replace the generator
Failed heating of a single cooking zone	Generator faulty	Repair or replace the generator