

XMC1200 CPU Card

For XMC1000 Family

CPU-12A-V1

XMC1200 CPU Card

Board User's Manual

Revision 1.0, 2013-03-08

Microcontroller

Edition 2013-03-08

**Published by
Infineon Technologies AG
81726 Munich, Germany**

**© 2013 Infineon Technologies AG
All Rights Reserved.**

Legal Disclaimer

The information given in this document shall in no event be regarded as a guarantee of conditions or characteristics. With respect to any examples or hints given herein, any typical values stated herein and/or any information regarding the application of the device, Infineon Technologies hereby disclaims any and all warranties and liabilities of any kind, including without limitation, warranties of non-infringement of intellectual property rights of any third party.

Information

For further information on technology, delivery terms and conditions and prices, please contact the nearest Infineon Technologies Office (www.infineon.com).

Warnings

Due to technical requirements, components may contain dangerous substances. For information on the types in question, please contact the nearest Infineon Technologies Office.

Infineon Technologies components may be used in life-support devices or systems only with the express written approval of Infineon Technologies, if a failure of such components can reasonably be expected to cause the failure of that life-support device or system or to affect the safety or effectiveness of that device or system. Life support devices or systems are intended to be implanted in the human body or to support and/or maintain and sustain and/or protect human life. If they fail, it is reasonable to assume that the health of the user or other persons may be endangered.

Revision History

Page or Item	Subjects (major changes since previous revision)
Revision 1.0, 2013-03-08	

Trademarks of Infineon Technologies AG

AURIX™, C166™, CanPAK™, CIPOS™, CIPURSE™, EconoPACK™, CoolMOS™, CoolSET™, CORECONTROL™, CROSSAVE™, DAVE™, DI-POL™, EasyPIM™, EconoBRIDGE™, EconoDUAL™, EconoPIM™, EconoPACK™, EiceDRIVER™, eupec™, FCOS™, HITFET™, HybridPACK™, I²RF™, ISOFACE™, IsoPACK™, MIPAQ™, ModSTACK™, my-d™, NovalithIC™, OptiMOS™, ORIGA™, POWERCODE™, PRIMARION™, PrimePACK™, PrimeSTACK™, PRO-SIL™, PROFET™, RASIC™, ReverSave™, SatRIC™, SIEGET™, SINDRION™, SIPMOS™, SmartLEWIS™, SOLID FLASH™, TEMPFET™, thinQ!™, TRENCHSTOP™, TriCore™.

Other Trademarks

Advance Design System™ (ADS) of Agilent Technologies, AMBA™, ARM™, MULTI-ICE™, KEIL™, PRIMECELL™, REALVIEW™, THUMB™, μVision™ of ARM Limited, UK. AUTOSAR™ is licensed by AUTOSAR development partnership. Bluetooth™ of Bluetooth SIG Inc. CAT-iq™ of DECT Forum. COLOSSUS™, FirstGPS™ of Trimble Navigation Ltd. EMV™ of EMVCo, LLC (Visa Holdings Inc.). EPCOS™ of Epcos AG. FLEXGO™ of Microsoft Corporation. FlexRay™ is licensed by FlexRay Consortium. HYPERTERMINAL™ of Hilgraeve Incorporated. IEC™ of Commission Electrotechnique Internationale. IrDA™ of Infrared Data Association Corporation. ISO™ of INTERNATIONAL ORGANIZATION FOR STANDARDIZATION. MATLAB™ of MathWorks, Inc. MAXIM™ of Maxim Integrated Products, Inc. MICROTEC™, NUCLEUS™ of Mentor Graphics Corporation. MIPI™ of MIPI Alliance, Inc. MIPS™ of MIPS Technologies, Inc., USA. muRata™ of MURATA MANUFACTURING CO., MICROWAVE OFFICE™ (MWO) of Applied Wave Research Inc., OmniVision™ of OmniVision Technologies, Inc. Openwave™ Openwave Systems Inc. RED HAT™ Red Hat, Inc. RFMD™ RF Micro Devices, Inc. SIRIUS™ of Sirius Satellite Radio Inc. SOLARIS™ of Sun Microsystems, Inc. SPANSION™ of Spansion LLC Ltd. Symbian™ of Symbian Software Limited. TAIYO YUDEN™ of Taiyo Yuden Co. TEAKLITE™ of CEVA, Inc. TEKTRONIX™ of Tektronix Inc. TOKO™ of TOKO KABUSHIKI KAISHA TA. UNIX™ of X/Open Company Limited. VERILOG™, PALLADIUM™ of Cadence Design Systems, Inc. VLYNQ™ of Texas Instruments Incorporated. VXWORKS™, WIND RIVER™ of WIND RIVER SYSTEMS, INC. ZETEX™ of Diodes Zetex Limited.

Last Trademarks Update 2011-11-11

Table of Contents

1	Overview	7
1.1	Key Features	7
1.2	Block Diagram	7
2	Hardware Description	8
2.1	Power Supply	8
2.2	Reset	9
2.3	Clock Generation	9
2.4	Boot Option	9
2.5	Debug Interface and virtual com port	9
2.6	LED	9
2.7	Potentiometer	10
2.8	Application Card connector	10
3	Production Data.....	12
3.1	Schematics	12
3.2	Layout and Geometry	15
3.3	Bill of Material	15

List of Figures

Figure 1	Block Diagram of XMC1200 CPU Card	7
Figure 2	XMC1200 CPU Card	8
Figure 3	Power Supply circuit.....	8
Figure 4	LEDs circuit	10
Figure 5	Potentiometer Circuit.....	10
Figure 6	Pinout of the 2x30 pin edge connector	11
Figure 7	Schematic 1 of 2 XMC1200 CPU Card	13
Figure 8	Schematic 2 of 2 XMC1200 CPU Card	14
Figure 9	XMC1200 CPU Card layout and geometry	15

List of Tables

Table 1	Debug connector X201	9
Table 2	LEDs Pinout	10
Table 3	XMC1200 CPU Card	15

Introduction

This document describes the features and hardware details of the XMC1200 CPU Card. This board is mounted with ARM® Cortex™-M0 based XMC1200 Microcontroller from Infineon Technologies AG and part of Infineon's XMC1000 offering of Kits

1 Overview

The XMC1200 CPU Card (CPU-12A-V1) houses the XMC1200 Microcontroller and a 2x30 pin edge for application expansion. This board along with application cards (e.g. LED Lighting Application Card) demonstrates the capabilities of XMC1200. The main use case for this board is to demonstrate the generic features of XMC1200 device including tool chain. The focus is safe operation under evaluation conditions. The board is neither cost nor size optimized and does not serve as a reference design.

1.1 Key Features

The XMC1200 CPU Card is equipped with the following features:

- XMC1200 (ARM® Cortex™-M0 based) Microcontroller, TSSOP38
- Connection to application cards via card edge connector
- Detachable SEGGER J-Link debugger and UART virtual COM port, with micro USB connector
- Five user LEDs
- Potentiometer, connected to analog input P2.5
- Power supply via Micro-USB connector

1.2 Block Diagram

Figure 1 shows the functional block diagram of the XMC1200 CPU Card.

Features include:

- On board Debugger, for downloading and debugging of application code
- Virtual com port for uart communication with terminal program e.g. Hyperterminal.
- 2x30 Card edge connector, for extension to application card e.g. LED Lighting and Motor Control Application Card.
- 5 User LEDs connected to GPIO P0.0, P0.2, P0.5, P0.6, P0.7
- Variable resistor R110 connected to Analog input P2.5
- All the pins of XMC1200 are accessible via the connector JP101, JP102, JP103 and JP104

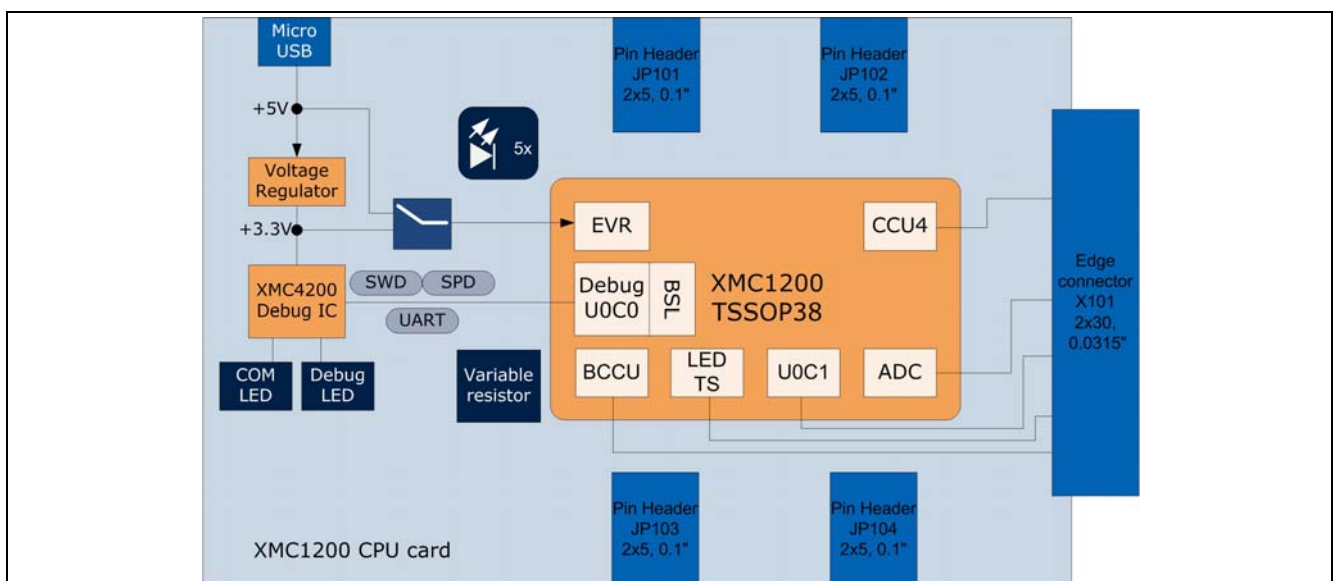

Figure 1 Block Diagram of XMC1200 CPU Card

2 Hardware Description

The following sections give a detailed description of the hardware and how it can be used.

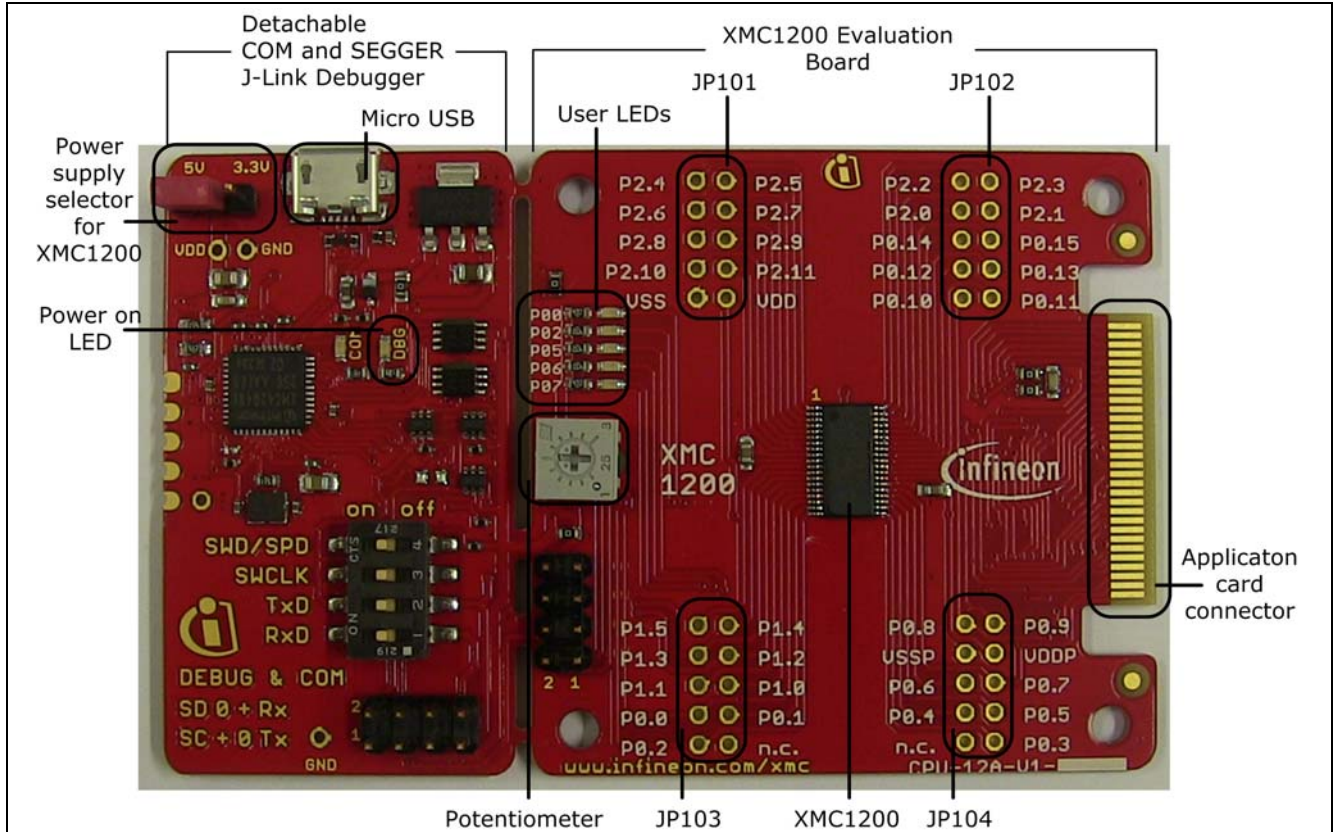

Figure 2 XMC1200 CPU Card

2.1 Power Supply

XMC1200 CPU Card is powered from the micro USB connector (5V); however, there is a current limit that can be drawn from the host PC through USB. If the CPU_12A_V1 board is used to drive other application card (e.g. Colour LED Card or White LED Card) and the total current required exceeds 500mA, then the board needs to be powered by external power supply connected to VDD and GND connection on board.

The XMC1200 device can operate by power supply of 1.8V till 5.5Vdc. On this board, 5Vdc is used to power the XMC1200 device. However, if user wants to power the XMC1200 device with 3.3Vdc, then, set Jumper at JP201 to 3.3V side.

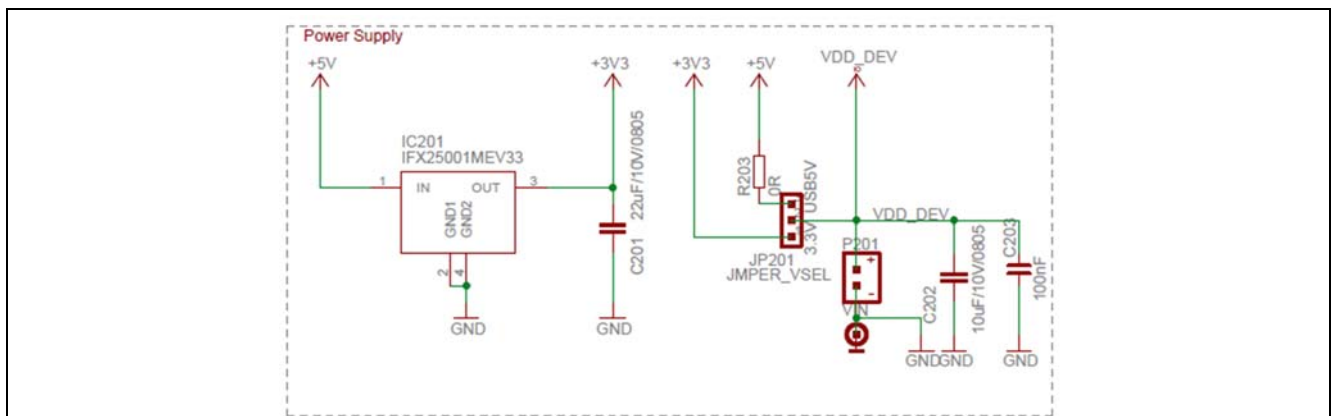

Figure 3 Power Supply circuit

2.2 Reset

XMC1200 does not have a reset pin, hence, user needs to unplug and replug the USB cable to achieve power-on with master reset to the XMC1200 device.

2.3 Clock Generation

No external clock source is required. XMC1200 has two internal oscillators DCO1 and DCO2. DCO1 has a clock output of 64MHz. DCO2 is used to generate the standby clock running at 32.768KHz which is used for Real Time Clock too. The main clock, MCLK and fast peripheral clock, PCLK, are generated from DCO1's output.

2.4 Boot Option

After power-on with master reset, XMC1200 device will enter different boot mode depend on the BMI (Boot Mode Index) value stored in XMC1200's flash configuration sector 0 (CS0). The BMI value pre-programmed in the XMC1200 CPU Card is User mode with debug enabled, hence, XMC1200 CPU Card will start to run the application code in its embedded Flash after power on reset.

2.5 Debug Interface and virtual com port

XMC1200 CPU Card has on-board debugger which supports Serial Wire Debug (SWD) and Single Pin Debug (SPD) as debug interface. SPD is a proprietary debugging protocol from Infineon Technologies and it requires only 1 pin for debug communication. The debugger also provides a virtual COM port which support UART communication via P1.3 (rx-in) and P1.2 (tx-out) of XMC1200. There is a 2x5 pins Header Debug connector X201.

Table 1 Debug connector X201

Pin	Signal Name	XMC1200 Signal	Description
1	SWCLK	P0.15	SWD clock signal
2	SWD(SPD)	P0.14	SWD / SPD signal
3	VDDP	VDDP	+5V
4	GND	VSSP	Ground
5	GND	VSSP	Ground
6	VDDP	VDDP	+5V
7	PC_TXD	P1.3	UART data received
8	PC_RXD	P1.2	UART data transmit

2.6 LED

The port pins P0.0, P0.2, P0.5, P0.6 and P0.7 are connected to LED101, LED102, LED103, LED104 and LED105 respectively. The LED is turns on by output 'Low' at the port pin.

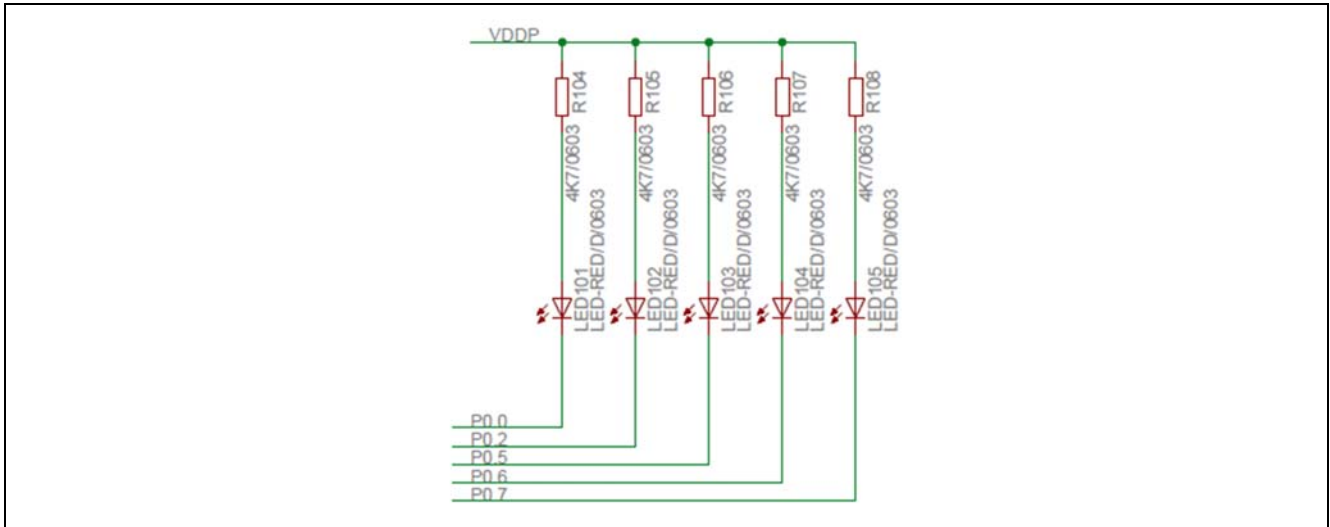

Figure 4 LEDs circuit

Table 2 LEDs Pinout

LED	XMC1200 Port Pin	Description
LED101	P0.0	Output 'Low' to on LED
LED102	P0.2	Output 'Low' to on LED
LED103	P0.5	Output 'Low' to on LED
LED104	P0.6	Output 'Low' to on LED
LED105	P0.7	Output 'Low' to on LED

2.7 Potentiometer

XMC1200 CPU Card provides a potentiometer R110 for ease of use and testing of the on-chip analog to digital converter. The potentiometer is connected to the analog input P2.5. The analog output of the potentiometer is the same the VDDP voltage supplied to the XMC1200 device.

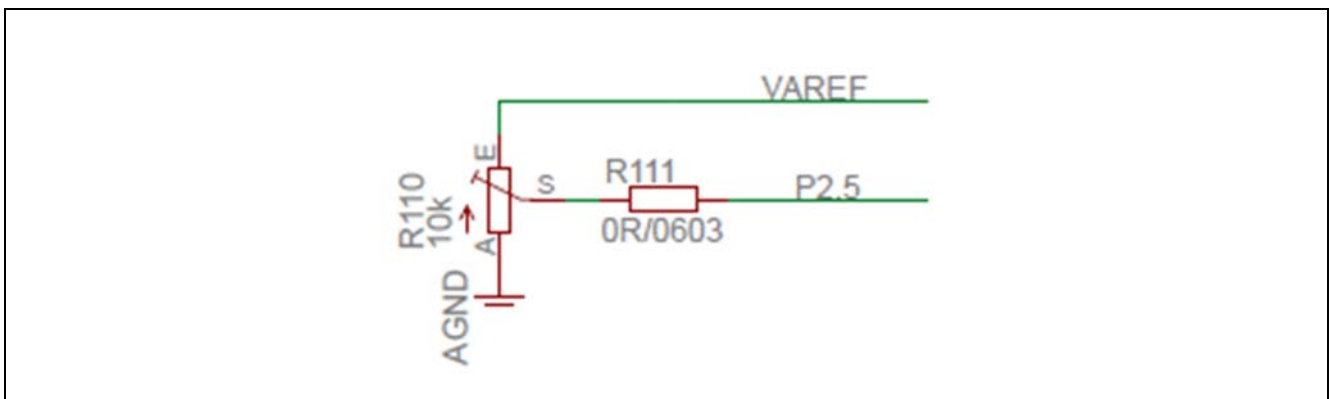

Figure 5 Potentiometer Circuit

2.8 Application Card connector

XMC1200 CPU Card has a 2x30 pins card edge connector. The mating connector is SAMTEC HSEC8-130-01-L-RA-XX.

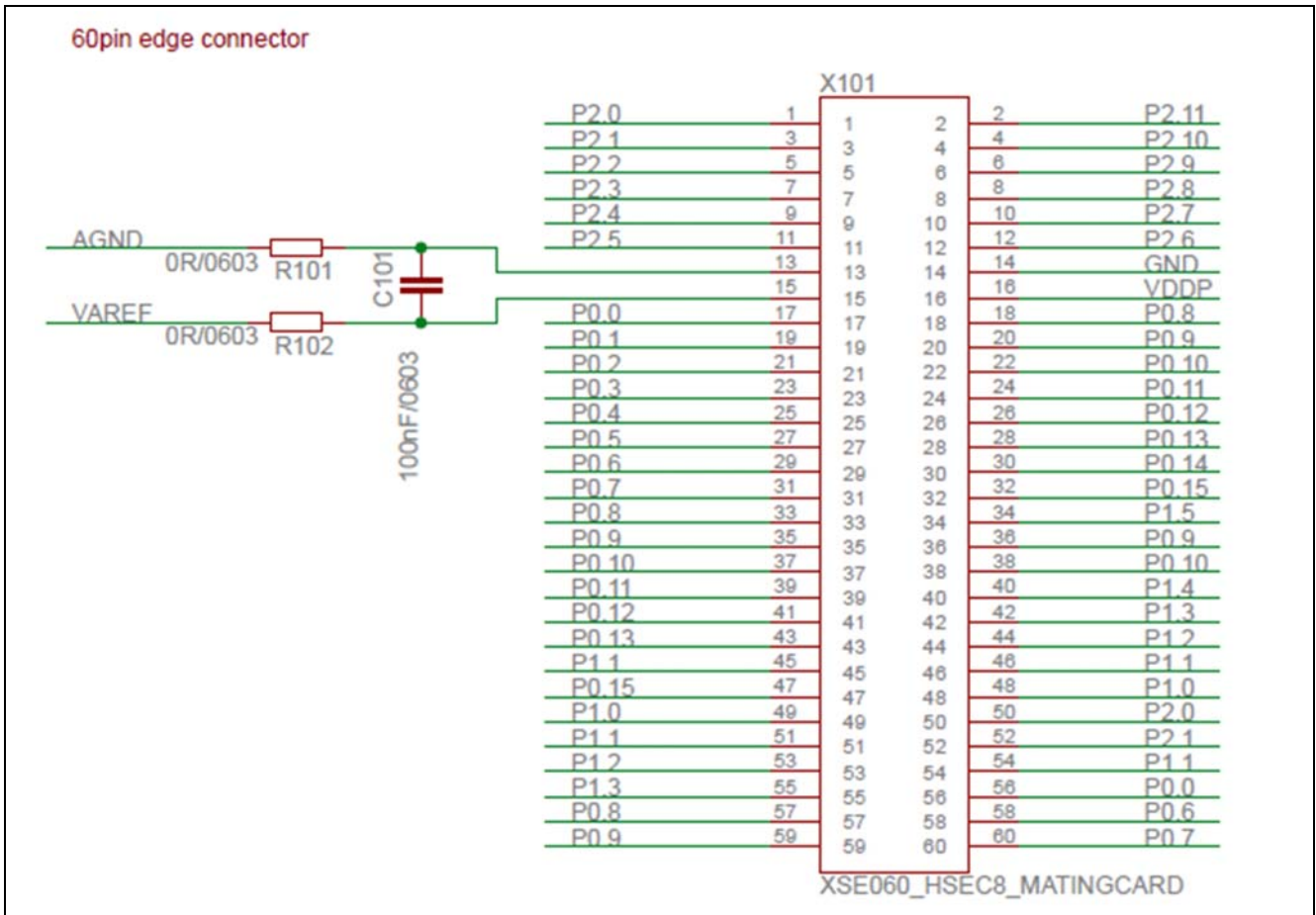

Figure 6 Pinout of the 2x30 pin edge connector

3 Production Data

3.1 Schematics

This chapter contains the schematics for the XMC1200 CPU Card:

- Figure 7: CPU, Pin Headers, Potentiometer and LED and 60pin Edge connector
- Figure 8: On-board Debugger, Power Supply

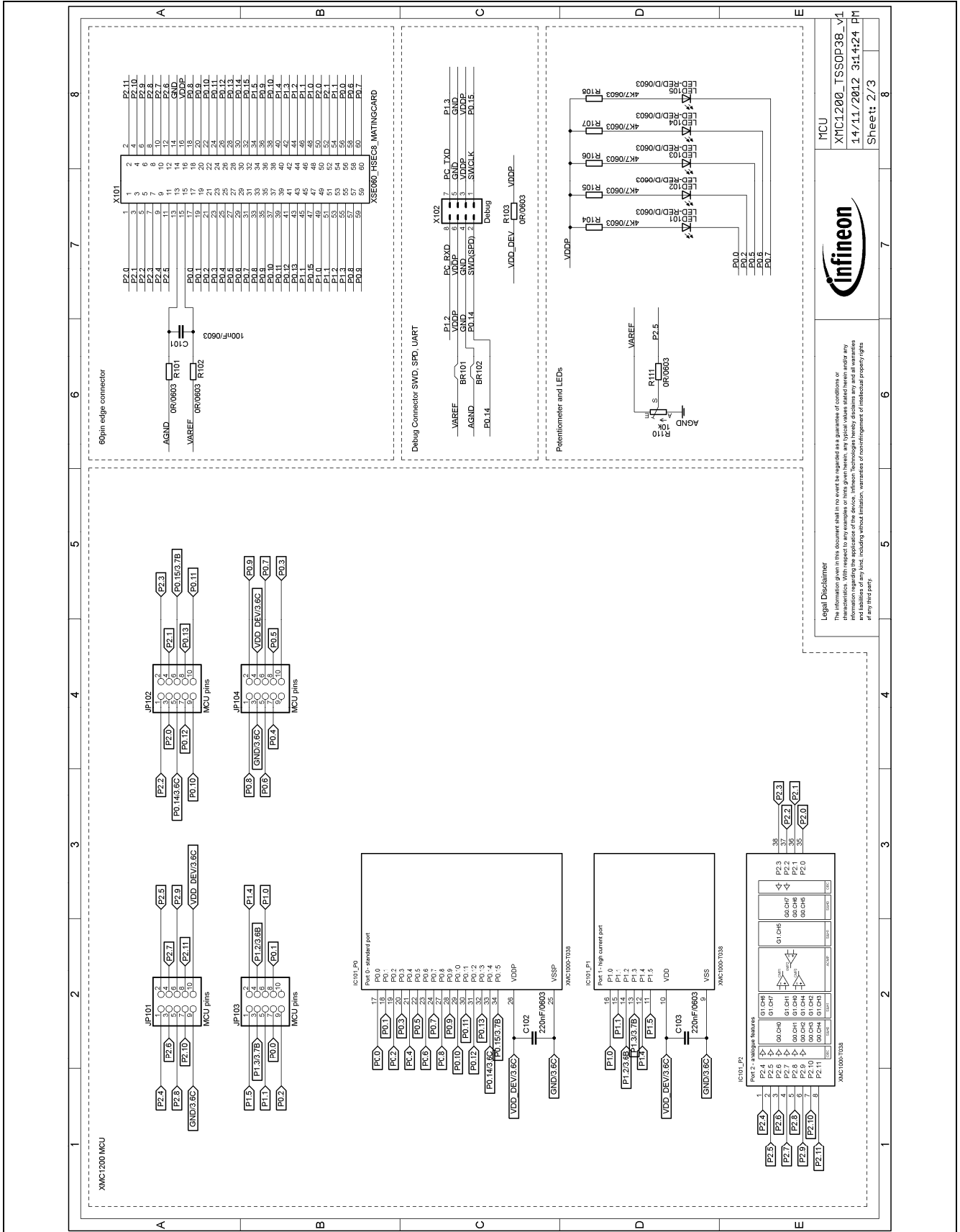

Figure 7 Schematic 1 of 2 XMC1200 CPU Card

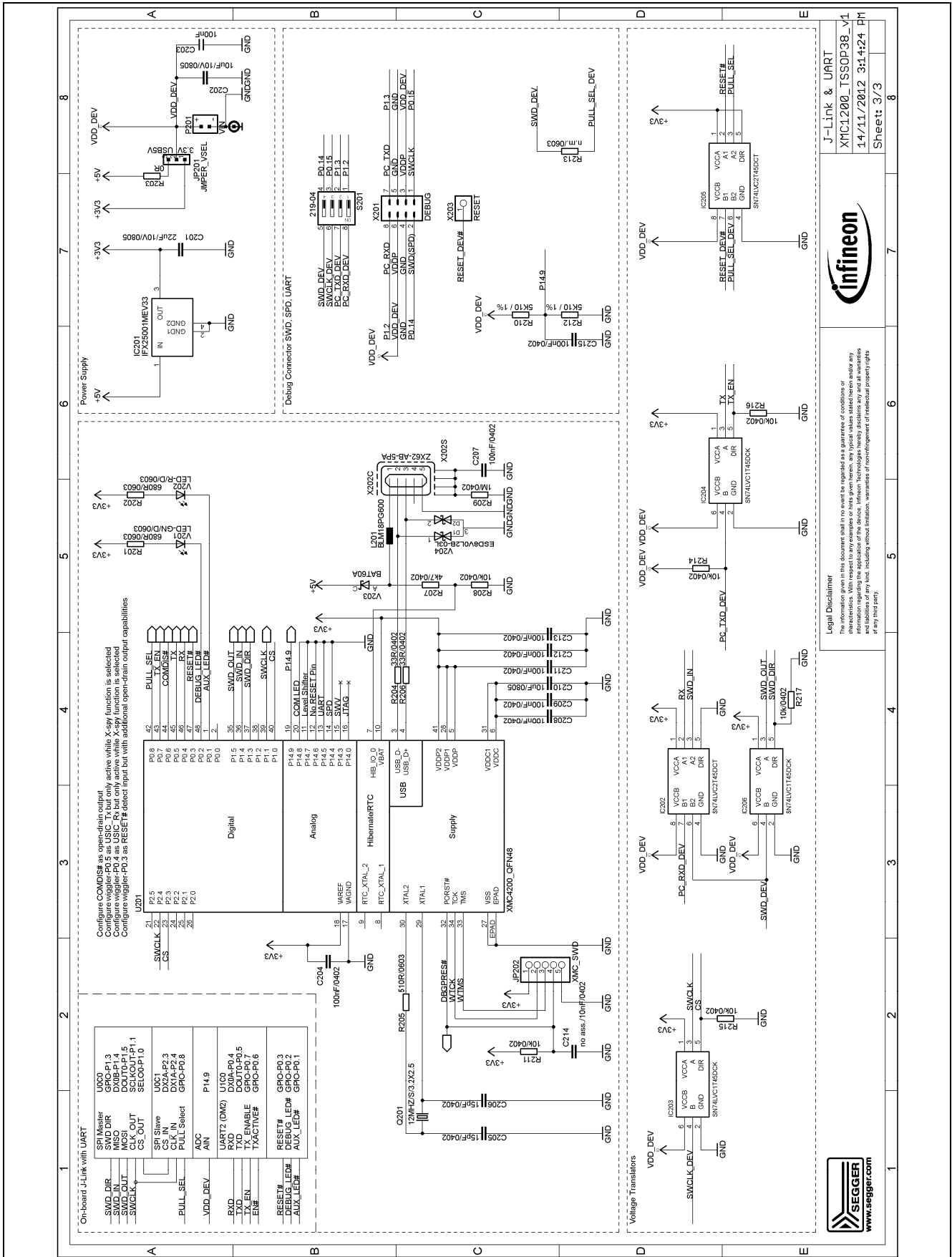

Figure 8 Schematic 2 of 2 XMC1200 CPU Card

3.2 Layout and Geometry

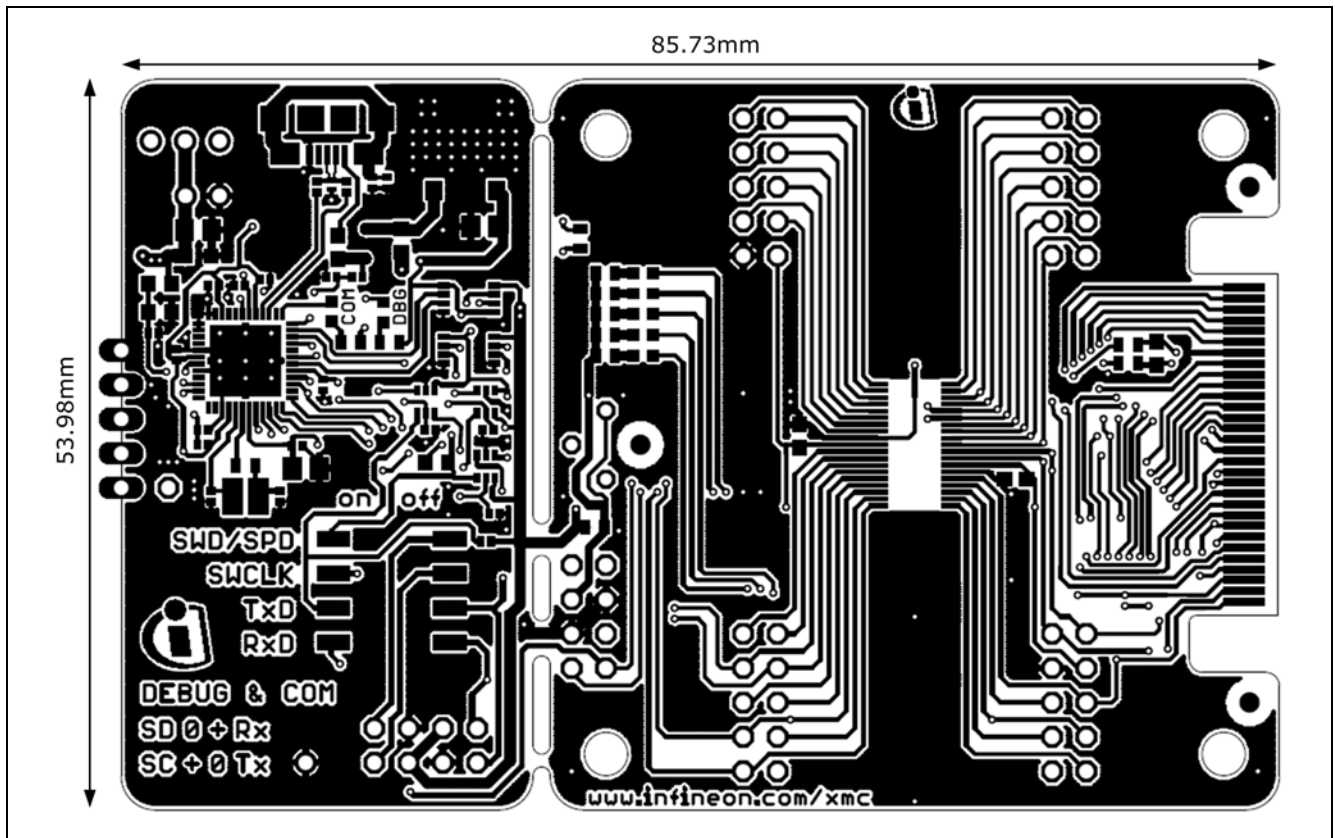

Figure 9 XMC1200 CPU Card layout and geometry

3.3 Bill of Material

Table 3 XMC1200 CPU Card

No.	Qty	Value	Device	Reference Designator
1	1	100nF/10V/10%/0603	Capacitor	C101
2	1	220nF/10V/10%/0603	Capacitor	C102
3	1	220nF/10V/10%/0603	Capacitor	C103
4	1	22uF/10V/10%/0805	Capacitor	C201
5	1	10uF/10V/10%/0805	Capacitor	C202
6	1	100nF/10V/10%/0603	Capacitor	C203
7	1	100nF/10V/10%/0402	Capacitor	C204
8	1	15pF/10V/10%/0402	Capacitor	C205
9	1	15pF/10V/10%/0402	Capacitor	C206
10	1	100nF/10V/10%/0402	Capacitor	C207
11	1	100nF/10V/10%/0402	Capacitor	C208
12	1	100nF/10V/10%/0402	Capacitor	C209
13	1	10uF/10V/10%/0805	Capacitor	C210
14	1	100nF/10V/10%/0402	Capacitor	C211
15	1	100nF/10V/10%/0402	Capacitor	C212
16	1	100nF/10V/10%/0402	Capacitor	C213

No.	Qty	Value	Device	Reference Designator
17	1	100nF/10V/10%/0402	Capacitor	C215
18	1	SN74LVC2T45DCT	Resistor	IC202
19	1	SN74LVC1T45DCK	Resistor	IC203
20	1	SN74LVC1T45DCK	Resistor	IC204
21	1	SN74LVC2T45DCT	Resistor	IC205
22	1	SN74LVC1T45DCK	Resistor	IC206
23	1	BLM18PG600	Ferrite Bead	L201
24	1	LED-RED/D/0603	Red ChipLED	LED101
25	1	LED-RED/D/0603	Red ChipLED	LED102
26	1	LED-RED/D/0603	Red ChipLED	LED103
27	1	LED-RED/D/0603	Red ChipLED	LED104
28	1	LED-RED/D/0603	Red ChipLED	LED105
29	1	12MHZ/S/3.2X2.5	Quarz	Q201
30	1	0R/0603	Resisto	R101
31	1	0R/0603	Resistor	R102
32	1	0R/0603	Resistor	R103
33	1	4K7/0603	Resistor	R104
34	1	4K7/0603	Resistor	R105
35	1	4K7/0603	Resistor	R106
36	1	4K7/0603	Resistor	R107
37	1	4K7/0603	Resistor	R108
38	1	10k	Potentiometer	R110
39	1	0R/0603	Resistor	R111
40	1	680R/0603	Resistor	R201
41	1	680R/0603	Resistor	R202
42	1	33R/0402	Resistor	R204
43	1	510R/0603	Resistor	R205
44	1	33R/0402	Resistor	R206
45	1	4k7/0402	Resistor	R207
46	1	10k/0402	Resistor	R208
47	1	1M/0402	Resistor	R209
48	1	5K10/1%/0603	Resistor	R210
49	1	10k/0402	Resistor	R211
50	1	5K10/1%/0603	Resistor	R212
51	1	10k/0402	Resistor	R214
52	1	10k/0402	Resistor	R215
53	1	10k/0402	Resistor	R216
54	1	10k/0402	Resistor	R217
55	1	JMPER_VSEL	1x3 Header	JP201
56	1	JUMPER	Red	JP201a
57	1	219-04	Switch - DIL	S201
58	1	MA04-2	2x4 Header	X102
59	1	MA04-2	2x4 Header	X202

No.	Qty	Value	Device	Reference Designator
60	1	LED-GN/D/0603	ChipLED	V201
61	1	LED-R/D/0603	ChipLED	V202
62	1	ESD8V0L2B-03L	Diode	V204
63	1	ZX62-AB-5PA	Micro-USB	X202
64	1	XMC1200-T038	Microcontroller, Infineon	IC101
65	1	IFX25001MEV33	3V3 regulator, Infineon	IC201
66	1	XMC4200_QFN48	Microcontroller, Infineon	U201
67	1	BAT60A	Diode	V203
68	1	BRIDGE10X10	BRIDGE10	BR101
69	1	BRIDGE10X10	BRIDGE10	BR102
70	1	no ass./10nF/0402	Capacitor	C214
71	1	no ass./MCU	2x5 pin header	JP101
72	1	no ass./MCU	2x5 pin header	JP102
73	1	no ass./MCU	2x5 pin header	JP103
74	1	no ass./MCU	2x5 pin header	JP104
75	1	no ass./XMC_SWD	1x5 pin header	JP202

www.infineon.com

Published by Infineon Technologies AG