

RHINO MOTION CONTROLS

RMCS-1110 v1.0

Hybrid AC Driver with ENABLE
(Max. 80Vdc and 7A per phase)

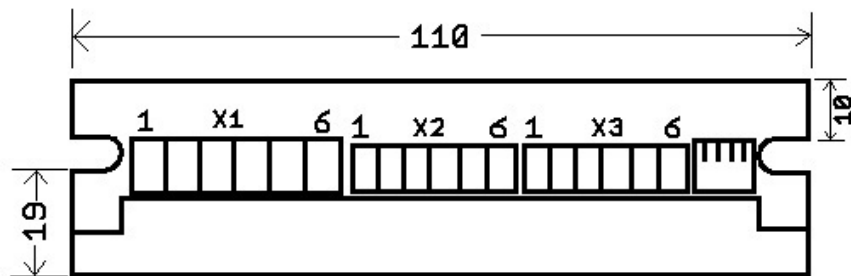
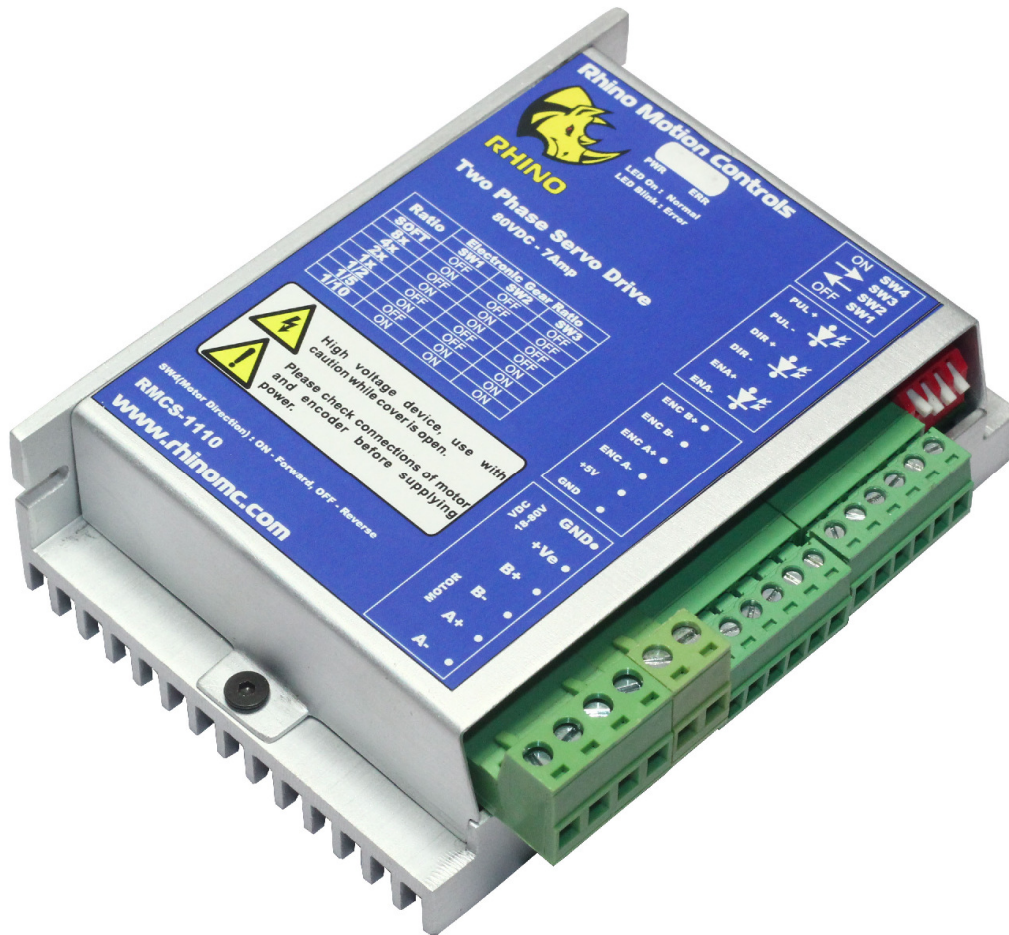

Front View

Installation Manual and Datasheet

<http://www.rhinomc.com>

RHINO MOTION CONTROLS

RMCS-1110 v1.0

Hybrid AC Driver with ENABLE
(Max. 80Vdc and 7A per phase)



Key Features

- Smooth and quiet operation at all speeds and extremely low motor heating
- Industrial grade performance for an alternating current servo motor
- Field oriented control based low voltage servo loop
- Fully configurable position and velocity loop
- Input supply voltage from 18VDc to 80VDC
- Delivers up to 7amps of continuous current
- Selectable gear-ratio for encoder with counts from 4000 to 10000 per revolution
- PULSE, DIRECTION and ENABLE inputs with opto-isolated interface
- Short-circuit protection for the motor outputs, over-voltage and under-voltage protection
- LED indication for power and error states

Description

Thank you for purchasing RMCS-1110, Hybrid AC Driver. RMCS-1110 is Rhino Motion Controls introductory hybrid low voltage AC drive designed for smooth and quiet operation without compromising on torque and control at higher speeds. It has short-circuit protection for the motor outputs, over-voltage and under-voltage protection and will survive accidental motor disconnects while powered-up.

The RMCS-1110 delivers a low-voltage servo performance using a field oriented control (FOC) current loop for two-phase hybrid PMSM motors. It also provides a fully configurable position and velocity loop with feed-forward variables to achieve close to zero lag in servo performance.

Two phase PMSM servo systems give an advantage of higher speed, faster response and very low motor heating.

The RMCS-1110's FOC control gains are calibrated on start-up based on motor characteristics and also adjusted dynamically while the motor is in motion. This control algorithm makes it capable of achieving better torque at higher speeds in comparison to comparable drives in its range.

The PULSE/STEP, DIRECTION and ENABLE inputs are optically isolated. Both inputs work with 2.5V, 3.3V or 5V logic drive signals. The input drive current is 5mA at 2.5V so almost all logic family (74LS, 74HC, etc.) can be used to drive these inputs.

The RMCS-1110 hybrid AC drive is warranted to be free of manufacturing defects for six months from the date of purchase. Please see the section on service, support and warranty at the end of this document.

<http://www.rhinomc.com>

Page 2

Hybrid AC Driver [RMCS-1110]

RHINO MOTION CONTROLS

RMCS-1110 v1.0

Hybrid AC Driver with ENABLE
(Max. 80Vdc and 7A per phase)



Technical Specifications

Specification	Min	Max	Units	Comments
Supply Voltage	18	80	Volts DC	Between +Ve and GND
Phase Current	0.5	7	Amps	As demanded by load
Servo Loop Speed	500	1000	Hz	
Power Dissipation	0	15	Watts	—
Short-Circuit Current	7	10	Amps	In case of motor terminal short
PUL and DIR Voltage	2.5	7	Volts DC	Between + and – input pins
Ambient Temp.	0	70	Celsius	
Humidity	0	95%		Non condensing
Step Frequency	—	200	kHz	
Direction Setup time	500	—	ns	Steps is clocked on positive edge

Mechanical Specifications

Specification	Details
Dimensions (L * W * H)	110mm * 77mm *33mm
Weight	155gms
Heat Sink	Anodized Aluminum 3mm thickness
Mounting Screw Holes	3.6mm minimum diameter

Caution

- Read this document carefully before installing and using you drive
- Inputs voltage to the drive must not exceed the maximum of 80VDC or it may damage the drive
- Reversing polarity power supplied to the drive will damage the drive or power supply
- Connecting the power supply wires to the terminals outputs of the motor coils will damage the drive
- Short-circuiting the motor terminals to +Ve power or to each other or to GND may damage the drive
- Excess humidity or condensation on the drive may damage the drive
- Voltage in excess of 7V between the PULSE+ and PULSE- or DIR+ and DIR- or ENA+ and ENA- input terminals may damage the opto-isolators
- Reverse voltage in excess of 7V between the PULSE- and PULSE+ or DIR- and DIR+ or ENA+ and ENA- input terminals may damage the opto-isolators
- Heat sink is designed to dissipate heat from the drive circuitry as long as the ambient temperature is less that 70 degrees Celsius. Ambient temperature in excess of that may damage the drive
- Do not un-plug the terminals of the motor while the drive is powered up and running

RHINO MOTION CONTROLS

RMCS-1110 v1.0

Hybrid AC Driver with ENABLE
(Max. 80Vdc and 7A per phase)



Power and Motor Terminal Assignments

Terminal No.	Terminal Name	Description
Terminal 1	A-	Motor Coil Phase A-
Terminal 2	A+	Motor Coil Phase A+
Terminal 3	B-	Motor Coil Phase B-
Terminal 4	B+	Motor Coil Phase B+
Terminal 5	+V	Power +Ve (18VDC to 80VDC Max wrt. GND)
Terminal 6	GND	Power Ground or Power -Ve

Encoder Terminal Assignments

Terminal No.	Terminal Name	Wire Colour	Description
Terminal 1	GND	BLACK	Power Ground or Power -Ve
Terminal 2	+V	RED	Power +Ve (5VDC wrt. GND)
Terminal 3	A-	GREEN	Motor Coil Phase A-
Terminal 4	A+	YELLOW	Motor Coil Phase A+
Terminal 5	B-	WHITE	Motor Coil Phase B-
Terminal 6	B+	BLUE	Motor Coil Phase B+

Pulse and Direction Input Assignments

Terminal No.	Terminal Name	Description
Terminal 1	ENA-	Enable (Motor Free) -Ve optically isolated input
Terminal 2	ENA+	Enable (Motor Free) +Ve optically isolated input
Terminal 3	DIR-	Direction -Ve optically isolated input
Terminal 4	DIR+	Direction +Ve optically isolated input
Terminal 5	PUL-	Pulse -Ve optically isolated input
Terminal 6	PUL+	Pulse +Ve optically isolated input

Switch Selection Table for Step Selection

Resolution	SW1	SW2
1/10	ON	ON
1/5	OFF	ON
1/2	ON	OFF
1x	OFF	OFF

Switch (4): Sets Direction
SW4 ON – Forward Direction
SW4 OFF – Reverse Direction

RHINO MOTION CONTROLS

RMCS-1110 v1.0

Hybrid AC Driver with ENABLE
(Max. 80Vdc and 7A per phase)



RS-232 command port

A 4pin command port is available on the drive for debug and tuning routines. This port is assessable on the main drive board after opening the drive cover. The communication settings are given below along with a command list. A cable for connecting a RS-232 DB9 to the port is usually shipped with the drive.

After connecting it to a computer the drive can be accessed by simple commands using any terminal software. The baud rate of 115200bps is default with no flow control, 8 bit data and 1 stop bit.

The below list of commands can be used to read or write a register. A new line and carriage return is required to process any command.

Command and Register Table

Command List	Register Description	Default	Max
A	Position Proportional Gain	256	30000
B	Velocity Proportional Gain	4000	30000
C	Velocity Integral Gain	25	30000
D	Velocity Damping	100	30000
E	No. of Poles in Motor Construction	50	100
F	Encoder Counts Per Revolution	4000	10000
G	Current Loop P-Gain	96	1000
H	Current Limit	2400	4000
I	Position Error Limit	8	200
J	Current Loop I-Gain	48	1000
K	Acceleration Feed-Forward	7	100
L	Home Position in Counts	0	0
N	Velocity Feed-Forward	65	30000
O	Position Integral Gain	48	1000
R	LED Trigger Level for Current	1200	4000

Additional Commands

Command List	Description	Default	Max
P	Go To Absolute Position	0	+/-32767
M	Go To Relative Position	0	+/-32767
S	Start Data Stream	0	
T	Stop Data Stream	0	
a	Go to Acceleration and Deceleration	1	1000
s	Go to Velocity Setting	0	2000

<http://www.rhinomc.com>

RHINO MOTION CONTROLS

RMCS-1110 v1.0

Hybrid AC Driver with ENABLE
(Max. 80Vdc and 7A per phase)



X	Set Defaults
Y	Save to EEPROM

Power Supply Selection

The general rule of thumb to get the most out of the motor is to drive it with a supply voltage that is at least 3 to 4 times its rated supply voltage. A DC regulated power supply with good low-ESR decoupling capacitors on its output is recommended for best performance of this drive.

LED Status and Error Codes

There is a single LED on this drive for power and error status messages. In case the LED is blinking or flickering please check all connections and powered-down, wait for 5 seconds and then power-up the drive once again.

LED State	Message
Green LED ON and steady	Powered up and calibrated
Red LED Flickering randomly	Current Trigger Level Achieved
Red LED blinking	Short circuit on motor terminals or drive message to connection error

Guide to General Problems

Problem Symptom	Possible Reasons and Solutions
Motor is not rotating	Drive is not powered up Motor is not connected properly to the drive Drive is in an error state, check LED status Pulse and Direction inputs are not connected properly or are not supplying enough current
Motor rotates in the wrong direction LED is blinking	Motor Phase connections may be reversed Check LED status messages in this document and check connections and voltages accordingly
Drive is not powering up (no LED)	Drive might be damaged due to incorrect installation or handling Check that the connectors to the drive are tightly plugged in Check the supply voltage is adequate and in correct polarity Drive might be damaged due to incorrect installation or handling
Erratic Motion on Motor	Power supply voltage not stable or regulated Motor Coil damaged or not connected to the drive correctly Current setting on the motor too high Control signals of Pulse or Direction are not connected properly or not supplying enough voltage and current

<http://www.rhinomc.com>

RHINO MOTION CONTROLS

RMCS-1110 v1.0

Hybrid AC Driver with ENABLE
(Max. 80Vdc and 7A per phase)



Motor stalls during accelerating

Control signal interference due to power supply or environmental noise

Motor load is too high

Acceleration is too high

Gain settings is too low of the Motor

Power Supply is too low for Motor or Speed

Excessive Motor or Drive Heating

Drive is damaged

Power supply voltage is too high

Not enough cooling or ventilation for motor or drive

Control Signal Connection NPN pull-down

In this connection technique all the signal +ve inputs are connected to a common high voltage VCC. The opto-isolators LED is turned-on by a pull-down on the -Ve terminals by an NPN-transistor output

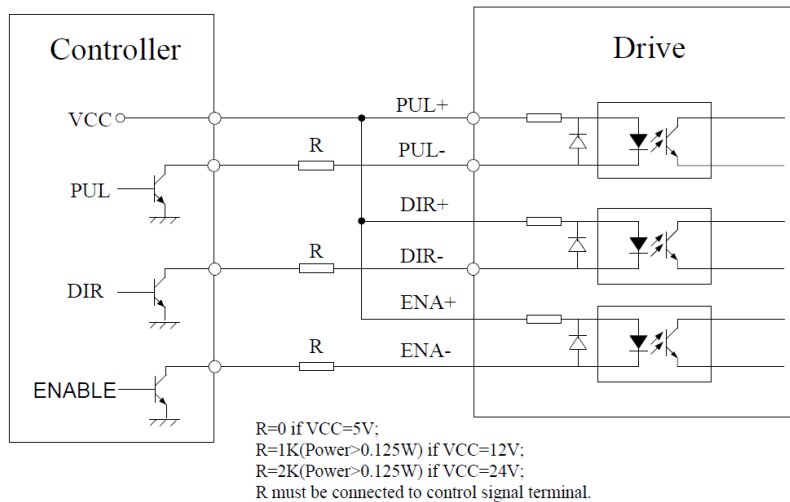

Control Signal Connection PNP pull-up

In this connection technique all the signal -ve inputs are connected to a common low voltage GND. The opto-isolators LED is turned-on by a pull-up on the +Ve terminals by an PNP-transistor output

RHINO MOTION CONTROLS

RMCS-1110 v1.0

Hybrid AC Driver with ENABLE
(Max. 80Vdc and 7A per phase)

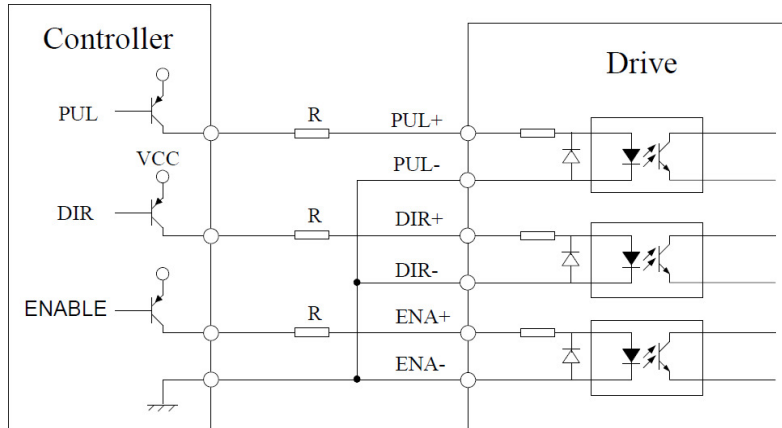

R=0 if VCC=5V;
R=1K(Power>0.125W) if VCC=12V;
R=2K(Power>0.125W) if VCC=24V;
R must be connected to control signal terminal.

Control Signal Connection Differential

In this connection technique each input is differential controlled and no necessity for a common voltage

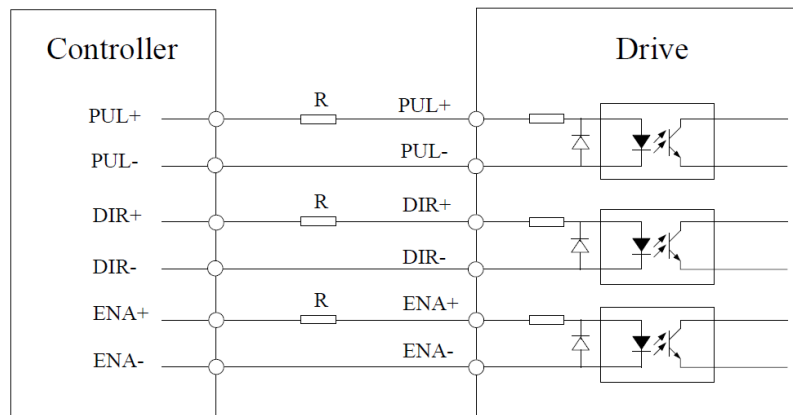

R=0 if VCC=5V;
R=1K(Power>0.125W) if VCC=12V;
R=2K(Power>0.125W) if VCC=24V;
R must be connected to control signal terminal.

2-phase, 4-lead Motors Connections

4 lead motors are the least flexible but easiest to wire. Speed and torque will depend on winding inductance. In setting the drive output current, multiply the specified phase current by 1.4 to determine the peak output current.

RHINO MOTION CONTROLS

RMCS-1110 v1.0

Hybrid AC Driver with ENABLE
(Max. 80Vdc and 7A per phase)

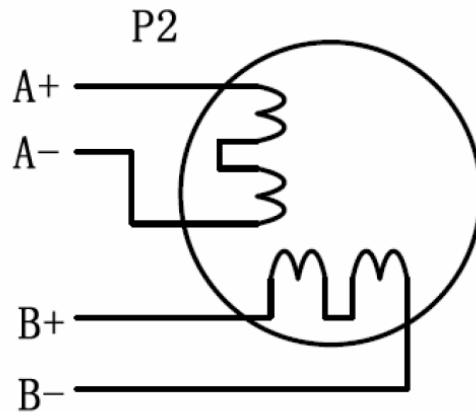

Service and Support

Service and support for this product are available from the Rhino Motion Controls Web site (<http://www.rhinomc.com>) and our customer service email: info@rhinomc.com

Six-Month Warranty

Rhino Motion Controls (rhinomc.com) warrants its products against defects in materials and workmanship for a period of 6 months from shipment delivery. During the warranty period, Rhino Motion Controls will either, at its option, repair or replace products which proved to be defective.

Exclusions

The above warranty does not extend to any product damaged by reasons of improper or inadequate handlings by customer, improper or inadequate customer wirings, unauthorized modification or misuse, or operation beyond the electrical specifications of the product and/or operation beyond environmental specifications for the product.

Obtaining Warranty Service

To obtain warranty service, please contact our customer service department at info@rhinomc.com before returning product for service. Please make sure that you have gone through this entire installation manual and datasheet before deciding that your product is liable for replacement or repair under this 6-month warranty. Customer shall prepay shipping charges for products returned to Rhino Motion Controls for warranty service, and Rhino Motion Controls shall pay for return of products to customer.

Warranty Limitations

<http://www.rhinomc.com>

RHINO MOTION CONTROLS

RMCS-1110 v1.0

Hybrid AC Driver with ENABLE
(Max. 80Vdc and 7A per phase)



Rhino Motion Controls makes no other warranty, either expressed or implied, with respect to the product. Rhino Motion Controls specifically disclaims the implied warranties of merchantability and fitness for a particular purpose. Some jurisdictions do not allow limitations on how long and implied warranty lasts, so the above limitation or exclusion may not apply to you. However, any implied warranty of merchantability or fitness is limited to the 6-month duration of this written warranty.

Disclaimer

Copyright © Rhino Motion Controls, 2012

Neither the whole nor any part of the information contained in, or the product described in this manual, may be adapted or reproduced in any material or electronic form without the prior written consent of the copyright holder.

This product and its documentation are supplied on an as-is basis and no warranty as to their suitability for any particular purpose is either made or implied.

This document provides preliminary information that may be subject to change without notice.