

---

**IVIE Enterprises**

[www.ivie-ent.com](http://www.ivie-ent.com) Ph:(918)254-5161 or (888)262-5161 Fax:(918)250-4807





**FM-1500HD,  
1700HD,  
2000, & 2300**

**Section II  
Parts and Service Manual**

(78179F)

## MAINTENANCE OF THE MACHINE

 **WARNING:** Maintenance must be done by authorized personnel only.

 **WARNING:** Disconnect the electrical plug from the electrical outlet before doing any repairs or maintenance to the machine.

Clean your machine frequently. It will have longer life and need fewer repairs. Replace damaged or worn parts with the correct Clarke Technology parts.

 **CAUTION:** Keep all fasteners tight. Keep all adjustments according to specifications.

---

## MANTENIMIENTO DE LA MAQUINA

 **AVISO:** El mantenimiento debe ser efectuado por personal autorizado.

 **AVISO:** Desconecte siempre el enchufe de la caja de enchufe de la red antes de efectuar cualquier operación de mantenimiento o reparación.

Limpie regularmente su máquina. La guardará más tiempo. Evitará así los gastos de reparación. Cambie las piezas desgastadas o dañadas sólo usando piezas originales adecuadas CLARKE TECHNOLOGY.

 **CUIDADO:** Aprete todas las sujeciones. Efectúe todos los reglajes según las indicaciones descritas en el libro de instrucciones.

---

## ENTRETIEN DE LA MACHINE

 **AVERTISSEMENT:** L'entretien ne peut être effectué que par un membre du personnel agréé.

 **AVERTISSEMENT:** Débranchez toujours la fiche de la prise réseau avant de procéder à toute opération d'entretien ou à une réparation.

Nettoyez régulièrement votre machine. Elle durera plus longtemps. Vous éviterez des frais de réparation. Remplacez les pièces usagées ou endommagées par les pièces d'origine Clarke Technology appropriées.

 **ATTENTION:** Resserrez toutes les fixations. Effectuez tous les réglages selon les indications figurant dans le manuel d'utilisation.

## Switches

 **WARNING:** All electrical repairs must be done by authorized personnel only. The machine must be tested after electrical repairs are made to make sure it is safe to operate. Disconnect the electrical plug from the outlet before doing any electrical repairs to this machine.

The start and stop switches are in the handle. If any part of the switch is not operating, replace the part. If any part of the electrical system of the machine is not operating or is damaged, replace the part. Make sure all connections are tight. Return the machine to a Clarke Technology Service Branch or a Clarke Technology Authorized Service Center for electrical repairs and testing.

---

## INTERRUPTORES

 **AVISO:** Todas las reparaciones eléctricas deben ser efectuadas sólo por técnicos autorizados. Después de cada reparación, hay que comprobar el aislamiento eléctrico. Desconecte siempre el enchufe del cable de alimentación antes de realizar cualquier reparación eléctrica en la máquina.

Los interruptores arranque/parada se encuentran en el mango. Si un componente del interruptor no funciona, cambie este componente. Si una pieza del sistema eléctrico de la máquina no funciona o está dañada, cambie la pieza. Mande la máquina a un centro de mantenimiento autorizado CLARKE TECHNOLOGY o al centro técnico CLARKE TECHNOLOGY más cercano para las reparaciones o comprobaciones del sistema eléctrico.

---

## INTERRUPTEURS

 **AVERTISSEMENT:** Toutes les réparations électriques ne peuvent être effectuées que par des techniciens agréés. Après toute réparation électrique, l'isolation électrique de la machine doit être vérifiée. Débrancher toujours la fiche du câble d'alimentation avant d'effectuer toute réparation électrique sur la machine.

Les interrupteurs de marche/arrêt se trouvent dans la poignée. Si une pièce de l'interrupteur ne fonctionne pas, remplacer cette pièce. Si une pièce du système électrique de la machine ne fonctionne pas ou est endommagée, remplacer cette pièce. Renvoyer la machine dans un centre d'entretien agréé Clarke Technology ou au centre technique Clarke Technology le plus proche pour faire effectuer les réparations et les vérifications du système électrique.

**CLARKE TECHNOLOGY Floor Maintainer**  
**Models 1500HD, 1700HD, 2000, 2300**  
**Sub-Assemblies Available - Reference Assembly Drawing**  
**Beginning with Serial No. ZE (4/01)**

Gear Unit Assembly	Part No. 503542
Locking Cam Assembly Includes Items: 14, 15, 16, 17 & 135	Part No. 501440
Handle Tube Assembly (2300 only)	Part No. 503970
Handle Tube Assembly (1500HD, 1700HD & 2000)	Part No. 503941

**CLARKE TECHNOLOGY Floor Maintainer**  
**Accessories Available**

<b>ACCESSORY</b>	<b>FM-2300</b>	<b>FM-2000</b>	<b>FM-1700HD</b>	<b>FM-1500HD</b>
Polishing Brush	490912	480916	460908	450914
Scrubbing Brush Bassine	490914	480918	460912	450918
Steel Wire Brush	490916	480924	460918	450916
Nylon Scrub Brush (metal back)		480932	460946	450962
Flagged Nylon Brush (metal back)			460970	450968
Nylon Scrub Brush (wood back)			460972	
Flagged Nylon Brush (wood back)			460973	
Dry Carpet Cleaning Scrub Brush		11406A	11405A	
Sanding Disc Assembly		480206	460215	450214
Grinding Disc Assembly w/6 stones			500212	450212
Replacement Stones			451212	451212
Perma Grip Drive Pad Assembly	66105A	505991	505990	66102A
Super Grip Drive Pad Assembly		37011A	37088A	
Solution Tank Assembly	508641	508641	508641	508641
Spray Buff Attachment	440570	440570	440570	440570
Lambswool Polishing Pad	495904	485904	465908	455908

**IVIE Enterprises**

[www.ivie-ent.com](http://www.ivie-ent.com) Ph:(918)254-5161 or (888)262-5161 Fax:(918)250-4807

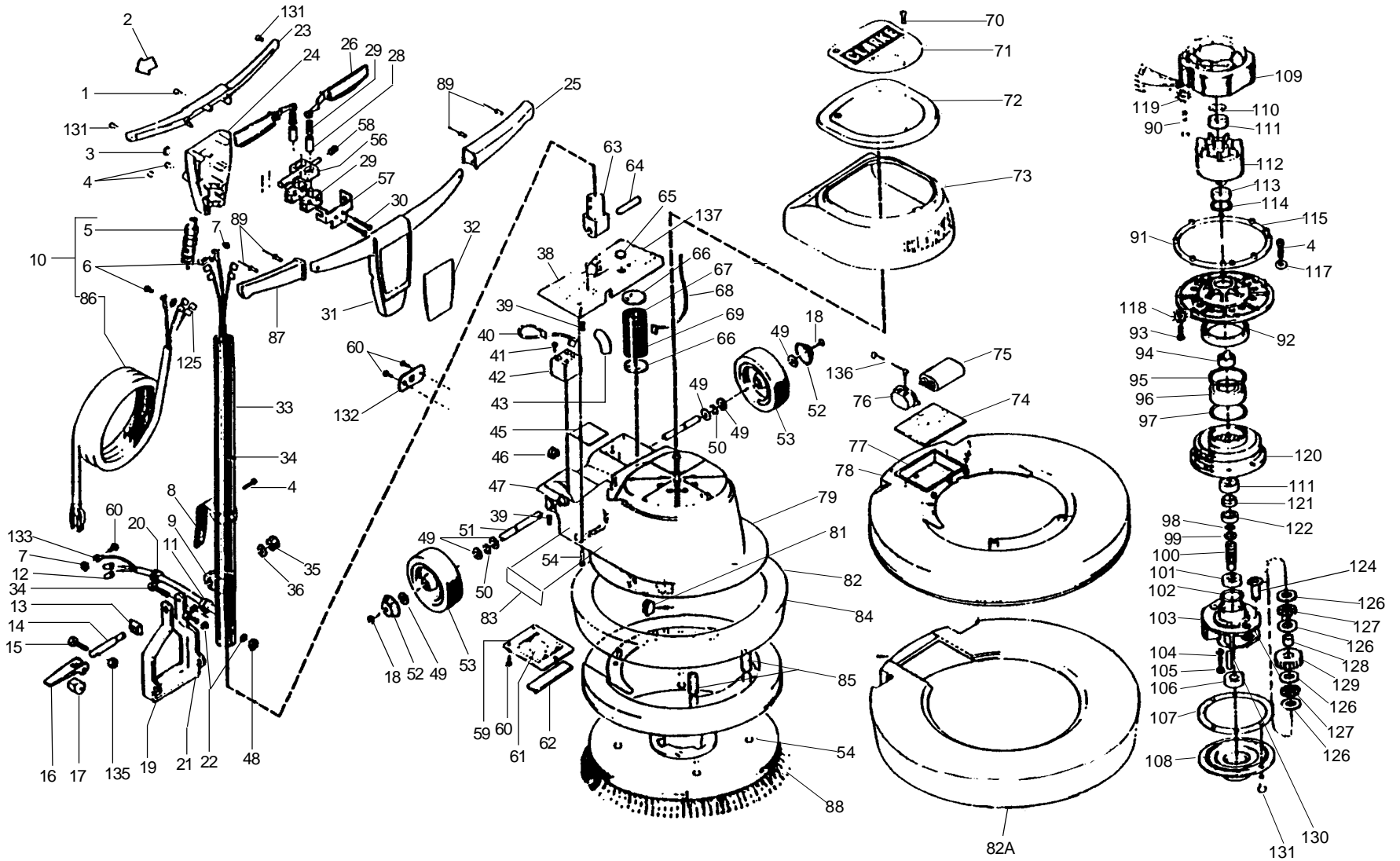

CLARKE TECHNOLOGY Floor Maintainer  
Models 1500HD, 1700HD, 2000, 2300 Assembly Drawing 4/01

**CLARKE TECHNOLOGY Floor Maintainer**  
**Models 1500HD, 1700HD, 2000, 2300**  
**Assembly Parts List 4/01**

Ref	Part No.	Description	Qty.
1	962391	Screw - 10-24 x 1 Soc Cap	1
2	445178	Label - Interlock	1
3	501302	Plug - Button	1
4	962289	Screw - ¼-20 x ¾	7
	962289	Screw-¼-20 x ¾ (FM-2300)	5
5	467504	Strain Relief	1
	497504	Strain Relief (FM-2300)	1
6	962015	Screw - 10-24 x ¾ Pan Hd	2
7	980675	Washer-190IDx4060DExThd	3
8	504540	Hook - Cord	1
9	502040	Clamp - Handle Tube	1
10	908275	Cord Assm.-50 Ft.	1
	908279	Cord Assm.-50 Ft. (FM-2300)	1
11	627561	Strain Relief	1
12	911178	Connector - 120V	2
	911178	Connector - 230V	3
13	743850	Guide - Handle Lock	1
14	501346	Bolt - Cam Lock	1
15	960969	Screw - Shoulder 5/16 x ¾ Lg.	1
16	503942	Handle - Cam Lock	1
17	508546	Stop - Clamp	1
18	962823	Screw - ¼-20 x ½ Pn St Mach	2
19	500342	Arm - handle	1
20	857557	Strain Relief	1
21	85812A	Screw - 5/16-18 x 7/8 Hx	1
22	980652	Washer-.319x.586x.078StLk	3
23	24507A	Housing - Handle & Switch	1
24	22109A	Cover-Switch Hsg	1
	22116A	Cover-Switch Hsg (FM 2300)	1
25	34612A	Grip-Handle, Left	1
26	505140	Lever - Switch	2
27	508340	Spring - Switch Lever	2
28	500241	Adapter - Switch	2
29	911690	Switch	2
30	84807A	Screw - 6-32 x 1 5/8 Pn St	2
31	24508A	Cover - Switch Front	1
32	70038A	Label,Switch HSG, FM-1500HD	1
	70039A	Label,Switch HSG,FM-1700HD	1
	70040A	Label, Switch HSG,FM-2000	1
	70041A	Label, Switch HSG,FM-2300	1
33	68318A	Tube - Handle	1
34	41925A	Cord - Interconnecting, Handle	1
35	980648	Washer-17/32 ID x 1 1/16 OD Pln	1
36	920365	Nut -1/2-13 Nylock	1
38	22105A	Cover - Main Hsg.	1
39	962233	Screw - ¼-20 x 5/16 St St	2
40	911736	Lead Asm - Capac/Relay	1
	911736	Lead Asm-Capac/Relay (FM-2300)	2
41	962606	Screw-6-32 x 3/8 Pn St Type	1
42◆	507572	Relay Mtr 1 hp	1
	507502	Relay-Mtr ¾ hp-1½ hp (FM-2300)	1
43	504740	Insulator - Elbow	1
44	930093	Rivet - 1/8 x 5/16	2
46	501142	Bushing	2
	501142	Bushing (FM-2300)	3
47	501141	Bushing - Link Arm	2
48	920110	Nut - 5/16-18 Elas Stop	1
49	980215	Washer-Wheel Thrust	6
50	167308	Ring-Retaining	2

Ref	Part No.	Description	Qty.
51	507741	Shaft - Wheel	1
52	501540	Cap - Hub	2
53	59961A	Wheel Asm, Grey	2
54	962337	Screw - ¼-20 x ½ Sc St Cap	9
56	38004A	Stop - Switch Interlock	1
57	61120A	Bracket - Stop Switch	1
58	67900A	Spring - Switch Lever	1
59	502342	Cover - Main Hsg., Bottom	1
	502345	Cover-Main Hsg. Bottom (FM-2300)	1
60	962826	Screw 10-24 x 3/8 Pn Hd	6
61	509806	Wiring Diagram	1
	509871	Wiring Diagram	1
62	502474	Cushion Capacitor	2
63	509240	Tongue - Handle Tube	1
64	506740	Pin-Handle Pivot	1
65	501345	Plug, Button	1
66	502403	Cushion Capacitor	2
67	502304	Cover, Capacitor	1
68	911737	Lead Asm., Capac/Line	1
69	502402	Capacitor	1
70	962727	Screw 8-32 x ½ Pn Typ T	3
71	70051A	Nameplate, ALTO	1
72	22106A	Cover, Drip	1
73	31237B	Bumper, Main Housing	1
74	502472	Cushion Capacitor, Bottom	1
75	502476	Capacitor, Run (FM-2300)	2
76	501371	Boot, Run, Capacitor(FM-2300)	2
77◆	502473	Cushion, Capacitor (FM-2300)	1
78	507871	Shield - (FM-2300)	1
79	24502C	Main Hsg.	1
	24503C	Main Housing (FM 2300)	1
81◆	506842	Plug, Hole	1
82	31233B	BumperFM-1500HD	1
	31234B	Bumper FM-1700HD	1
	31235B	Bumper FM-2000	1
82A	31236B	BumperFM-2300	1
83	77378A	Label, Clarke Technology	1
84	507841	ShieldFM-1500HD	1
	507851	ShieldFM-1700HD	1
	507861	Shield FM-2000	1
85	508242	Spacer, Brush, Shield	2
86◆	907078	Cord 50 Ft. (w/o clips)	1
	907094	Cord 50' (w/o clips) (FM 2300)	1
87	34613B	Grip Handle, Right	1
88	450914	Brush Asm., FM-1500HD	Ref
	460908	Brush Asm., FM-1700HD	Ref
	480916	Brush Asm., FM-2000	Ref
	490912	Brush Asm., FM-2300	Ref.
89	930108	Rivet 1/8 x 3/8 Red	4
90◆	85310B	Screw 10-24 x 2 Pn St	4
	85371A	Screw ¼-20 x 2 ¼ Pn (FM-2300)	4
91	500240	Adapter, Gear Unit	1
92	507640	Seal	1
93	962892	Screw ¼-20 x ¾ Pn St.	8
	962716	Screw ¼-20 x 1 ½ Pn St.	10
94	502407	Coupling Drive	1
95	507302	Ring, Retaining	1
96	902609	Bearing	1

**Parts List continued on page 26.**

NOTE: ◆ indicates a change has been made since the last publication of this manual.

**IVIE Enterprises**

[www.ivie-ent.com](http://www.ivie-ent.com) Ph:(918)254-5161 or (888)262-5161 Fax:(918)250-4807

**CLARKE TECHNOLOGY Floor Maintainer  
Models 1500HD, 1700HD, 2000, 2300  
Assembly Parts List 4/01 (Continued)**

Ref	Part No.	Description	Qty.
97	507604	Seal, Ring, Gear O'Ring	1
98	507341	O'Ring	1
99	507340	Ring, Retaining	1
100	507740	Shaft, Pinion	1
101	902580	Bearing	1
102	507603	Seal, Idler, Hsg., O'Ring	1
103	504248	Housing, Idler, Gear	1
104	980685	Washer $\frac{5}{16}$ ID x $\frac{7}{16}$ OD	2
105	962841	Screw $\frac{5}{16}$ -18 x $1\frac{1}{4}$	2
106	902573	Bearing	1
107	503403	Gasket, Gear Unit	1
108	502303	Cover, Ring, Gear Hsg.	1
109	503173	Field 1 HP	1
	503174	Field $1\frac{1}{2}$ HP, (FM-2300)	1
110	318303	Spring, Load	1
111	902550	Bearing	2
112◆	500409	Rotor 1HP	1
	500472	Rotor $1\frac{1}{2}$ HP (FM-2300)	1
113	902654	Bearing	1
114	467328	Ring, Retaining	1
115	508271	Spacer, Gear Unit (FM-2300)	1
117	980657	Washer $\frac{1}{4}$ Lck., (FM-1500HD FM-1700HD, FM-2000)	2
118	980614	Washer, Shakproof #1114	8
119	980603	Washer, Shakeproof #1110	
120	504241	Housing, Ring Gear	1
121	508240	Spacer, Oil Seal	1
122	507641	Seal, Pinion	1
124◆	507743	Pin, Idler Gear	2
125	911389	Clip, Terminal	
126	980045	Washer, Thrust	8
127	902040	Bearing, Thrust	4
128	902048	Bearing, Idler, Needle	2
129◆	503541	Gear, Idler	2
130	925536	Pin $\frac{5}{16}$ x $1\frac{1}{4}$ Dowel	1
131	962241	Screw 10-24 x $\frac{1}{2}$ Sc St.	10
132	66636A	Plate, Strain, Relief	1
133	911933	Clip, Terminal	1
	911948	Clip, Terminal (FM-2300)	1
134	85817A	Screw $\frac{5}{16}$ -18 x $\frac{7}{8}$ Hx	1
135	920349	Nut $\frac{1}{4}$ -20 Elas. Stop	1
137	506359	Plate, Fire & Sanding	1
NI	911194	Lead Asm., White, (FM-2300)	2

NOTE: ◆ indicates a change has been made since the last publication of this manual.

**IVIE Enterprises**

[www.ivie-ent.com](http://www.ivie-ent.com) Ph:(918)254-5161 or (888)262-5161 Fax:(918)250-4807

**Wiring Diagram - 120V 50-60 Hz  
FM 1500HD, FM 1700HD, FM 2000 4/01**

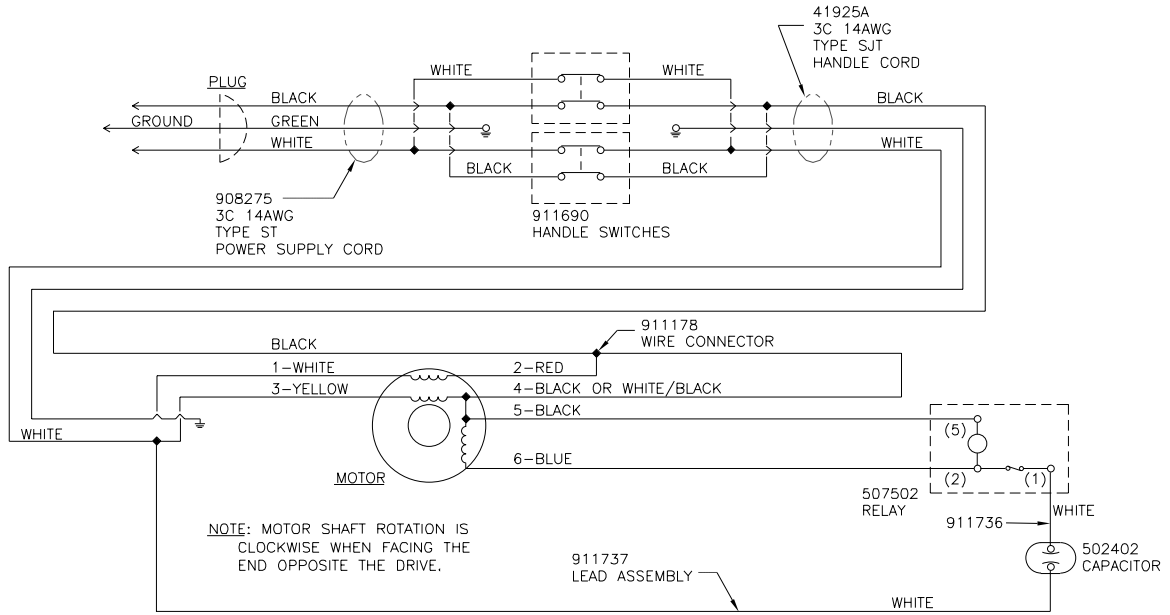

**Caution:** Do not bent the push-on male terminal tabs on the switch.

**Wiring Diagram - 230V 50-60 Hz  
FM 1500HD, FM 1700HD, FM 2000 4/01**

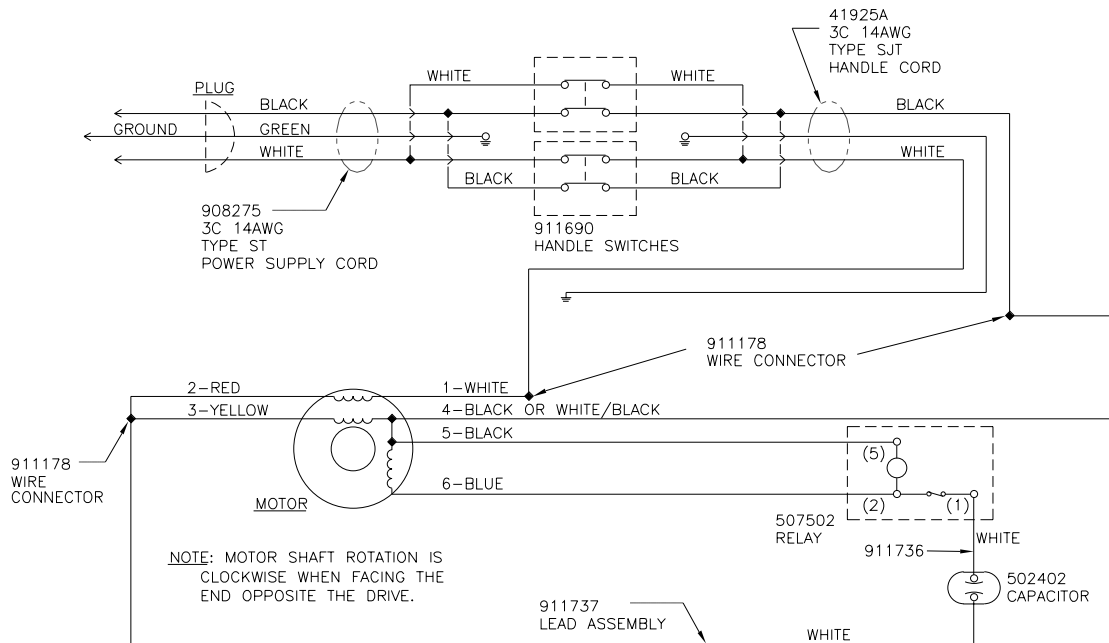

**WARNING: Repairs by qualified personnel only.**  
**AVERTISSEMENT: Reparations par personnel specialise seulement.**  
**ADVERTENCIA: Unicamente personal calificado deberian hacer reparaciones.**