

ZINGS 志诚



**ZK6201 CONTROLLER
USER'S MANUAL**

The clarification of notation used within this manual



WARNING

WARNING:

A WARNING indicates a potentially hazardous situation which, if not avoided, could result in death, serious personal injury or property damage.



CAUTION

CAUTION:

A CAUTION indicates a potentially hazardous situation which, if not avoided, could result in damage to equipment or property.



NOTE:

A NOTE provides other helpful information that does not fall under the warning or caution categories.



WARNING:

Read this entire manual pertaining to the work to be performed before installing, operating, or servicing this controller. Practice all plant and safety instructions and precautions. Failure to follow instructions can cause personal injury and/or property damage.

The engine or other type of prime mover should be equipped with an overspeed shutdown device to protect against runaway or damage to the prime mover with possible personal injury, loss of life, or property damage.

The overspeed shutdown device must be totally independent of the prime mover control system. An over temperature or low pressure shutdown device may also be needed for safety, as appropriate.



CAUTION—BATTERY CHARGING

To prevent damage to a controller that uses an alternator or battery-charging device, make sure the charging device is turned off before disconnecting the battery from the system.

Controllers contain static-sensitive parts. Observe the following precautions to prevent damage to these parts:

Do not disassemble the rear back of controller and touch the components or conductors on a printed circuit board.

Contents

1. Description.....	5
2. The Outline Dimension Drawings and Controller Wiring.....	6
3. Panel Operation	10
4. Control and Operation Instruction.....	12
5. Measure and Display Data	19
6. Warning and Shutdown Alarm.....	20
7. Parameters Setting	27
8. Installation Guide	54
9. LCD displays and Menu System.....	63
10. Technical Specification	67
Drawing	69

This manual is only suitable for ZK6201 Automatic control module, user must carefully read this manual first.

1. Description

ZK6201 is a new generation Automatic control module for single Genset, which adopts bran-new outline configuration, focus on the requirements of customers, and perfectly improves the performance of controller. It fully meets the auto control requirements of different kinds of Genset for user or special assembly factory.

The module also monitors and protects the engine, indicating operational status, fault conditions and metering on the front panel LCD and LED's.

- True RMS measure of voltage and current.
- Multi-Language menu.
- 128 x 64 pixel LCD display.
- 4 analog inputs for kinds of optional sensors that can be used for measuring oil pressure, coolant temperature, fuel level and so on; parameters can be configured by user.
- More outputs of configurable auxiliary control relays.
- More configurable isolated digital inputs.
- Buttons on control panel are used for selecting control modes, starting and stopping the operating procedure, displaying data and modifying the parameters. LED indicators are used for indicating the operation mode of controller and the running status of Genset, and LCD displays each measuring parameter and status.
- Flexible equipped with RS485, RS232 and USB, realizing remote monitor; or communicated with PC, fully realizing functions of remote signaling, telemetering and remote control, can read and set the running parameters of controller.
- With GPRS-DTU or Ethernet-DTU for remote communication instead of RS485, RS232, or USB port for remote communication.
- Optional CANbus, read and control the parameters for ECU engine.
- All connections of the controller by secure plug and socket, for ease and convenience to connect, move, maintain and replace the device. Optional ultra low temperature function, the ambient temperature is from -40°C to 70°C. Built-in smart charger and auxiliary circuit protect and control the charging of accumulators effectively, intelligent selection (12V/24V), long run floating charge, which stops automatically and begins charging by the charging device distribution in the genset when the genset starts.
- The box of controller, which accord with IEC standard production strictly, adopting steel structure and plastic spraying surface, is beautiful and durable. All internal input and output cable terminals arranged in unison.

2. The Outline Dimension Drawings and Controller Wiring
2.1 Outline dimensions of the controller

● Wall-mounted type

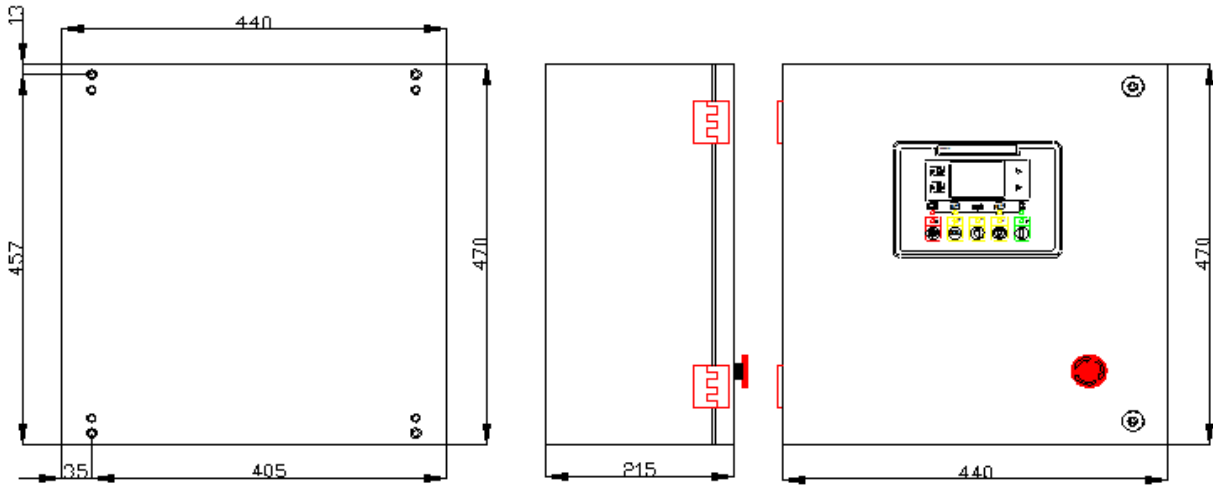

● Vertical type

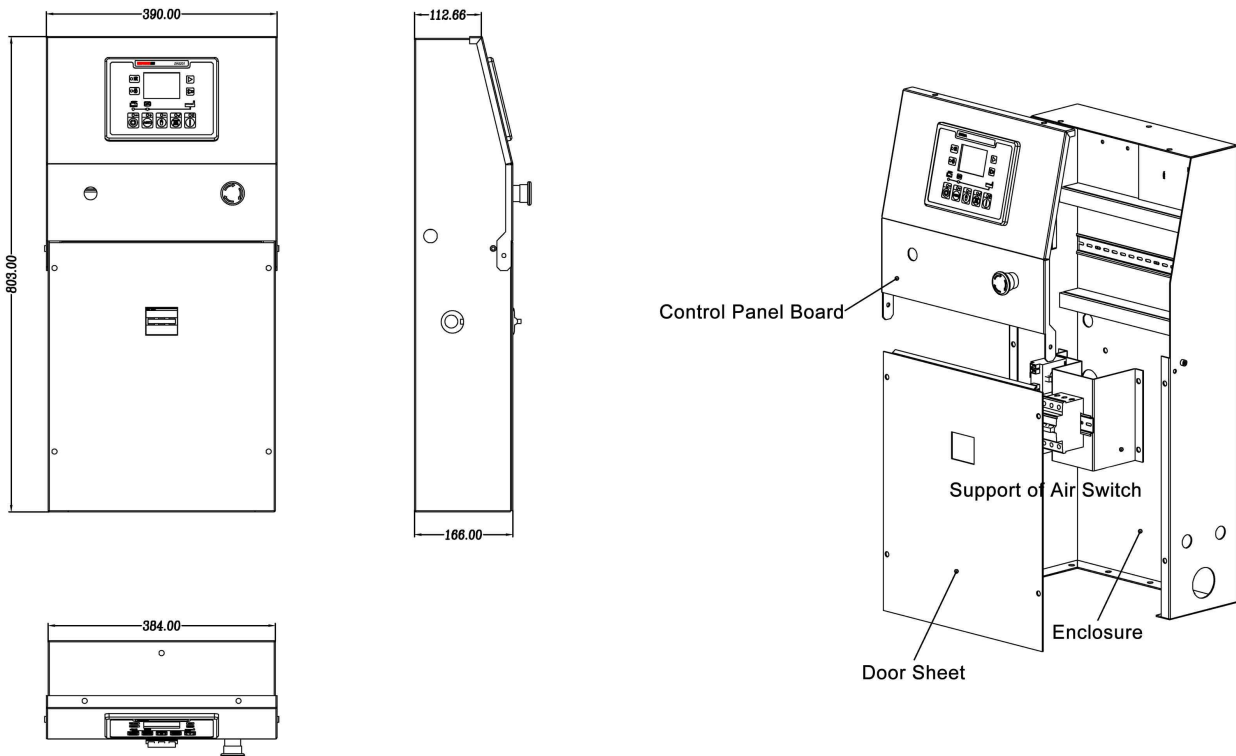

2.2 Following Details:

Module Dimensions	W192mm×H144mm
Panel Cutout	W174mm×H126mm
Thickness	D56m (without connection)

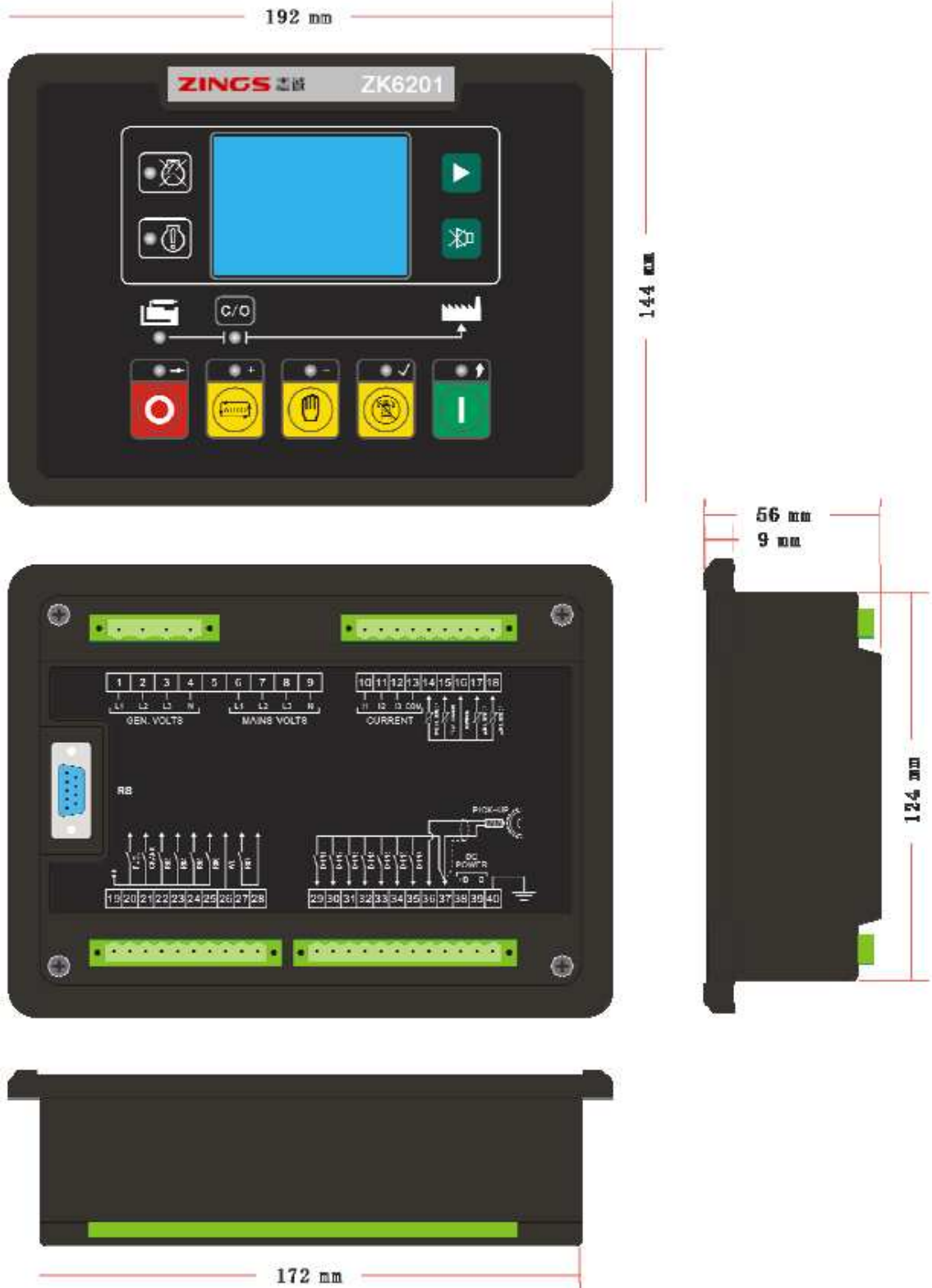

2.3 Terminal Connections:

Pin no.	Function Description	Signal	Dim
1	GEN. VL1-N input	0-330Vac	1mm ²
2	GEN. VL2-N input	0-330Vac	1mm ²
3	GEN. VL3-N input	0-330Vac	1mm ²
4	GEN. Neutral		1mm ²
5	Not used		
6	Not used		
7	Not used		
8	Not used		
9	Not used		
10	I1 Gen current input (S1)	0-5A	2.5mm ²
11	I2 Gen current input (S1)	0-5A	2.5mm ²
12	I3 Gen current input (S1)	0-5A	2.5mm ²
13	Comm. port for current inputs (S2)	0-5A	2.5mm ²
14	LOP sensor	<1KΩ	2.5mm ²
15	HET sensor	<1KΩ	2.5mm ²
16	Sensor com. port		2.5mm ²
17	Auxiliary sensor #1	Resistance type sensor (<1KΩ)	2.5mm ²
18	Auxiliary sensor #2	Resistance type sensor (<1KΩ)	2.5mm ²
19	Common port for relay outputs		2.5mm ²
20	Fuel solenoid relay output	N.O. contact, 16A/30Vdc	2.5mm ²
21	Start relay output	N.O. contact, 16A/30Vdc	2.5mm ²
22	Relay output 3 (GCB close/open)	N.O. contact, 3A/30Vdc, configurable (1)	1mm ²
23	Relay output 4	N.O. contact, 3A/30Vdc, configurable (2)	1mm ²
24	Relay output 5	N.O. contact, 3A/30Vdc, configurable (3)	1mm ²
25	Relay output 6	N.O. contact, 3A/30Vdc, configurable (4)	1mm ²
26	charger excitation power output	if not used, do not connect to negative	1mm ²
27	Relay output 7		1mm ²
28	Relay output 7	N.O. contact, 3A/30Vdc, configurable (5)	1mm ²
29	Configurable digital input signal 1	low level is active	1mm ²
30	Configurable digital input signal 2	low level is active	1mm ²
31	Configurable digital input signal 3	low level is active	1mm ²
32	Configurable digital input signal 4	low level is active	1mm ²
33	Configurable digital input signal 5	low level is active	1mm ²
34	Configurable digital input signal 6	low level is active	1mm ²
35	Configurable digital input signal 7	low level is active	1mm ²
36	Magnetic pick-up signal (+)	1-70Vac	2 core hield
37	Common for configurable inputs and magnetic pick-up signal (-)		
38	Battery supply (+B)		2.5mm ²
39	Battery supply (-B)	12V/24V (8-35Vdc continuous)	2.5mm ²
40	Ground		2.5mm ²



NOTE:

- Relay output 3 is configured as GCB close/open relay when default setting, however it can be reconfigured by user if required.

2.4 Typical Wiring Diagram

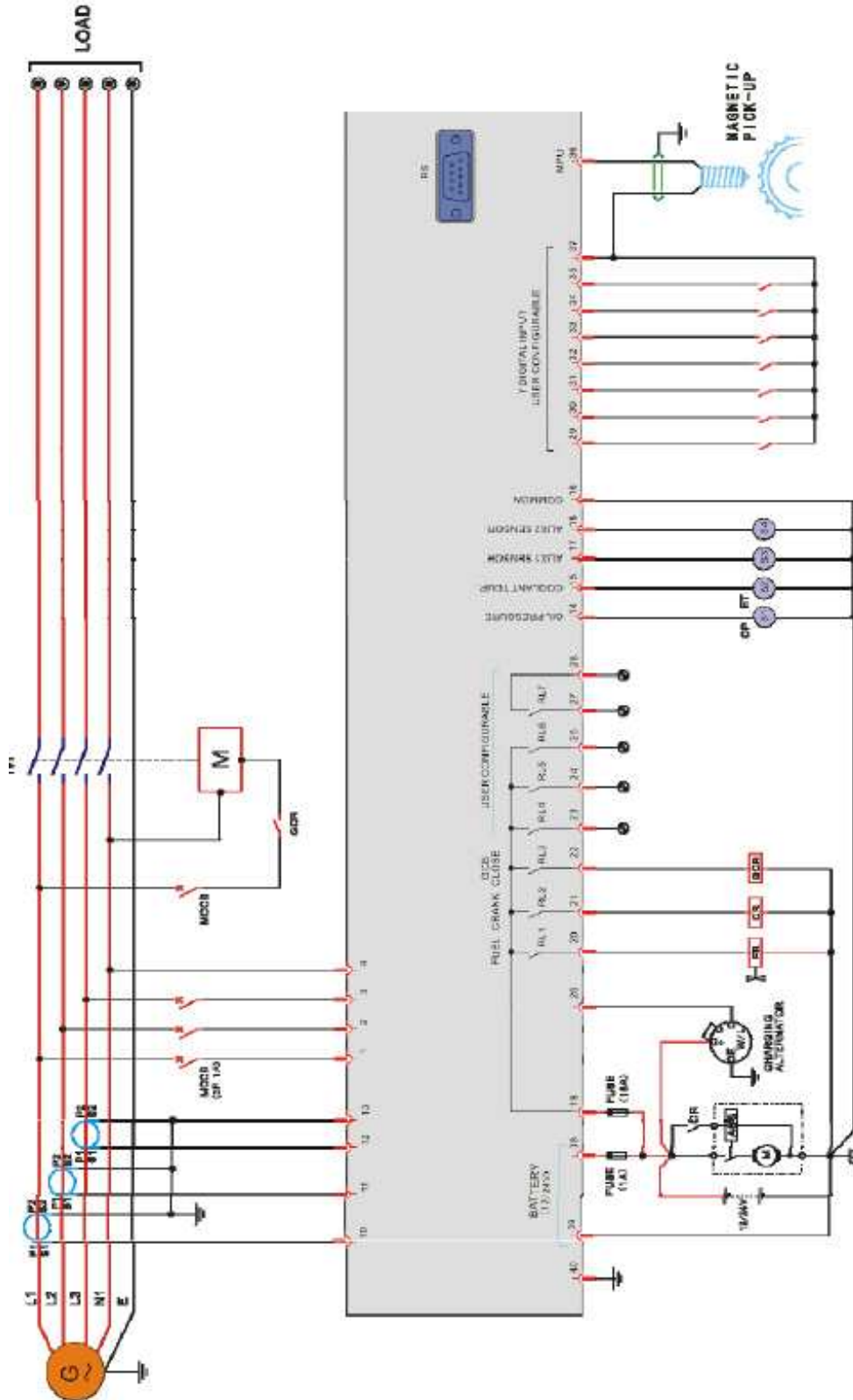







3. Panel Operation







The operation panel consists of 3 sections: LCD display indicating measurement parameters, LED indicator for common failure, and push buttons for Genset and selection of control modes.

LCD with 128*64 pixels can display multi-line data in the same time. LCD also has a backlight so that the operator can clearly read information day or night. After pressing any button the backlight will automatically turn off after a preset time.

The LCD display and its control push buttons provide a friendly operational interface for the operator to easily control the Genset, read information and parameter setting.

Control buttons and LED



Function Description	Tag
<p>Scroll Button Scroll menu for parameters display / enter into or exit parameters setting by pressing and holding this button for 2sec.</p>	
<p>MUTE / Lamp Test Button When failure occurs, alarm buzzer sounds. Pressing mute button will mute the sound. LCD displays mute icon. Press it again will clean mute function, buzzer continues to sound. Press and hold this button for 2sec, all LEDs illuminate simultaneously.</p>	
<p>AUTO Mode Button / LED / "+" Value Increase The push button is used for selecting "auto mode". When the controller is running in AUTO mode, the LED above the button is illuminated. The activation and deactivation of the "remote start signal input" controls the starting and stopping of the Genset. When in parameters setting mode, this button is used to increase value / scroll down menu.</p>	
<p>MAN Mode Button / LED / "-" Value Decrease The push button is used for selecting "manual mode". When the controller is running in MANUAL mode, the LED above the push button is illuminated. The Start and Stop push buttons control the starting of the Genset. When in parameters setting mode, this button is used to decrease value / scroll up menu.</p>	
<p>TEST Mode Button / LED / "✓" Confirm Parameters Configure The push button is used for selecting "test mode". When controller is running in TEST mode, the LED above the push button is illuminated, the controller starts the generator simulating the activation of "remote start signal". When in parameters setting mode, this button is used to enter into submenu /confirm modification.</p>	
<p>START Button / LED / Return The push button is used for manually start the Genset. When controller is running in MANUAL mode, press this button to start the generator. When in parameters setting mode, this button is used to return.</p>	

<p>STOP / RESET Button / “→” Move Setting</p> <p>The Push button is used for manually stops the Genset. No matter what mode the controller is running, press and hold this button for 2sec to stop the generator, the mode of the controller will be default to “MAN” mode automatically from “AUTO” or “TEST” mode and the generator will be shut down after cool down period, during the cool down period if you press and hold this button for 2sec again, the generator will be shut down immediately.</p> <p>If failure occurs, press this button, the shutdown alarm lockout can be cleared. When in parameters setting mode, this button is used to move to next parameters setting position.</p>	
<p>C/O Button</p> <p>It is used to close/open the switch of Gen when controller is running in MANUAL mode.</p>	
<p>Shutdown Alarm (FAILURE) LED</p> <p>The LED will illuminate permanently when shutdown alarm occurs.</p>	
<p>Pre-alarm (WARNING) LED</p> <p>The LED will illuminate permanently when pre-alarm occurs.</p>	
<p>GEN. Normal LED</p> <p>Gen. normal LED will illuminate after both voltage and frequency of the Gen. Reach loading voltage and frequency.</p>	
<p>GCB Closed LED</p> <p>LED will illuminate when GCB is closed and power supplied by Gen, LED will flash when GCB failure occurs.</p>	

4. Control and Operation Instruction

The controller has 3 modes: AUTO, MANUAL and TEST.

4.1 Operation Modes Setting:

Operation	Description
Press and hold the “AUTO” button for 2sec, the LED above the button is illuminated; the controller is running in “AUTO” mode.	
Press and hold the “MAN” button for 2sec, the LED above the button is illuminated; the controller is running in “MAN” mode.	
Press and hold the “TEST” button for 2sec, the LED above the button is illuminated; the controller is running in “TEST” mode.	



NOTE:

- Only 1 mode can be selected from above 3 modes.
- Controller keeps the states for the previous mode when changing the operation mode, then implements the control procedure of the next mode according to the present states.

4.2 AUTO Control Sequence:

The controller is running in “AUTO” mode.

Generator Auto Start Sequence:



NOTE:

- To achieve remote start, one of configurable inputs must be defined as remote start signal.

The Start delay timer is activated, when it times out, the preheat relay output is energised (if preheat function selected), the timer starts. When it times out, the fuel relay output is energised, and operates the fuel solenoid of the engine. After 300ms delay, the start relay output is energised, the start motor engages and begins to crank. When the engine speed reaches the crank cutout RPM, the start relay output is de-energised and the safety-on delay starts. When the safety-on times out, if the controller detects that the parameters of the Genset such as voltage, frequency, oil pressure, coolant temperature are normal, and no other failure is detected this indicates the Genset has successfully started and running normally. The LCD displays the Genset Measurement Parameters.

When Generator is running normally, Gen. Normal LED illuminates, the timer for GEN. ON delay is activated, when it times out, GCB close/open relay closes, then the transfer switch switches on Gen. The Gen Aux. Switch’s contact feeds back a signal to a configurable input on the controller. GCB closed LED illuminates.

**NOTE:**

- When remote signal is active, the start-delay timer is activated, if remote start signal is inactive during this period, the start delay timer terminates immediately, the controller terminates the starting procedure, then recovers to the original standby status.
- During cranking or idle period, if the remote start signal is inactive, the controller stops the start procedure, then recovers to the original standby status.
- Under any conditions, GEN. ON delay only can be started after Safety-on Delay times out.

**NOTE:**

The start motor will power off while cranking if there are one of the following conditions occur:

- The generator's frequency reaches the preset value (configurable cranking cutout value);
- The AC engine speed reaches **crank cutout value**;
- Generator's Voltage reaches the **crank cutout value** (optional);
- Charger voltage reaches **crank cutout value** (optional);
- Cutout P-delay time's up (optional);
- Cranking time's up.

Controller can not implement crank procedure in one of following conditions:

- The generator's frequency reaches the preset value (configurable cranking cutout value);
- The AC engine speed reaches **crank cutout value**;
- Generator's Voltage reaches the **crank cutout value** (optional);
- LOP switch is opened or oil pressure is higher than **crank cutout value** (optional).

**CAUTION:**

If magnetic pickup is not used, to avoid damage to the start motor please make sure the generator's voltage is higher than the measurable value of controller while cranking, since the crank cutout signal is sensed from the generator voltage and frequency.

**NOTE:**

Above control procedure, assumes that one of configurable inputs has been configured as **Gen Aux. Switch Closed** and connects the switch's N.O. Aux. contact signal to this port. If you do not configure an input as **Gen Aux. Switch Closed**, then the GCB closed LED illuminates is only an indication that the GCB close/open relay should have been closed.

If you have selected idle function, the idle relay will be closed at the same time as the crank relay is closed, the idle timer will begin counting down after successful crank, when it times out, the idle relay opens, other procedure is the same as above.

**NOTE:**

Controller will not detect under voltage, under frequency, under speed, and charge failure during idle period.

Repeat Crank: During the crank period, if the engine can not ignite and controller will not output start signal during crank rest. Once crank rest timer times out the start relay energises once again and will attempt to start engine again. The above procedure will be repeated until engine successfully ignites or reaches the preset number of crank attempt.

If any shutdown alarm occurs during crank, controller will stop cranking immediately, and the Genset only can be restarted after clearing the failure and reset.

Start Failure: When the procedure above repeats again and again and reaches the preset number of crank attempt, the crank relay output is then de-energised. The failure LED illuminates and the LCD displays Fail to Start.

**CAUTION:**

If Fail to Start occurs, operator must check the whole Genset system to find out failure reason, only after clearing the failure can press “STOP / RESET” button to relieve fault lock out status, and restart the Genset.

Generator shutdown sequence:

When remote start signal is inactive, GCB close/open relay de-energises, Gen is off load, the timer for cool down is activated, when it times out, the fuel relay de-energises, generator stops and recovers to its standby status.

**NOTE:**

When remote start signal is inactive, directly enter into cooldown status if none relay is defined as GCB close/open relay output.

Stop Failure: When cool down times out, the fuel relay opens and the timer for Stop delay begins. If the controller detects that the voltage of the generator or oil pressure or the speed of engine is greater than the cutout values or LOP switch is open, when it times out, the failure LED illuminates and the LCD displays **Fail to stop**.

**NOTE:**

After stop failure, the controller will not energise the crank relay output if the failure has not been removed and the controller reset.

4.3 MAN control Sequence:

The controller is running in “MANUAL” mode.

Generator starting sequence:

Pressing “START” button the fuel relay is energised, and operates the fuel solenoid of engine, After 300ms delay, the start relay output is energised, the start motor engages and begins to crank, When the engine speed reaches the crank cutout RPM, the start relay output is de-energised and the safety-on delay starts. When the safety-on times out, if the controller detects that the parameters of the Genset such as voltage, frequency, oil pressure, coolant temperature are normal, and no other failure is

detected this indicates the Genset has successfully started and running normally. The LCD displays the Genset Measurement Parameters.

After both voltage and frequency of generator respectively reached the loading value, the Gen. Normal LED illuminates, the GCB close/open relay will not be closed automatically.

Press the “C/O” button of Gen to close the Gen switch manually, then Gen is on load, the Gen Aux. switch’s contact feeds back the signal to a configurable input on our controller, GCB closed LED illuminates. Press the “C/O” button of Gen again to open the Gen switch manually, the Gen is off load, the GCB closed LED is turned off at the same time.

**NOTE:**

- When the controller is running in “MANUAL” mode, the Gen must be normal, or the “C/O” button of Gen will be disabled.

Generator stopping sequence:

Press “STOP” button, GCB close/open relay opens, the generator is off load, the cool down timer starts, when it times out, the fuel relay is de-energised, then the fuel solenoid opens immediately, generator stops and goes to standby status.

If press “STOP” button again during cool down period, generator stops immediately without cool down time.

4.4 TEST control Sequence:

When the Controller is running in “TEST” mode means it simulates remote start signal is activated. There are two kinds of “TEST” modes, one is “Test with load”, another is “Test without load”, and they can be selected through parameter setting.

Test with load: GCB close/open relay will be closed after the generator is started successfully and running normally, then Gen will be on load.

Test without load: GCB close/open relay will not be closed after the generator is started successfully and running normally, the Mains remain on load.

4.5 The start and stop sequence of engine whose fuel solenoid is N. O. type:

There are two kinds of fuel solenoids for an engine, one is N.C. type, the valve of this solenoid is closed when the engine is in standby and it can be opened by switching on power; another is N.O. type, the valve of this solenoid is opened when engine is in standby and it can be closed by switching on power. All control sequences above are for N.C. type.

Start control sequence for N.O. type:

During the starting sequence the fuel relay of controller will not energise, fuel solenoid is off power, fuel solenoid is normally open so no signal required for fuel solenoid to activate.

Stop control sequence for N.O. type:

During the controller’s stop sequence, the fuel relay energises, fuel solenoid is on power, the fuel solenoid closes the fuel valve and the engine begins to stop. After a delay (same as Stop delay) fuel relay deenergises, disconnecting the supply from the fuel solenoid.

Other control sequences same as engine whose fuel solenoid is N. C. type.

4.6 Idle function:

For **idle** function configure one of the configurable outputs as **idle**.
Refer to the flow chart **4.10** for start and stop for **idle** control flows.

**NOTE:**

Controller will not detect under voltage, under frequency, under speed, and charge failure during idle period.

4.7 Preheat function:

For **Preheat** function, configure one of the configurable outputs as **Preheat**, the controller has 5 selectable preheat control modes as below:

Mode 1 — during preheat time, preheat relay output energises.

Mode 2 — during preheat time, preheat relay output energises until the successful ignition.

Mode 3 — during preheat time, preheat relay output energises until safety-on delay times out.

Mode 4 — one of the configurable inputs is defined as **Preheat**, preheat relay output energises when this configurable input is active, and de-energises when configurable input is inactive.

Mode 5 —the A-sensor 2 use is defined as **Preheat**, preheat relay output energises when the temperature falls below the **Preheat ON** value, and de-energises until the temperature reaches the **Preheat OFF** value.

For preheat mode 1 to 3, please refer to the flow chart **4.10** for start and stop for **Preheat** control flows.
For preheat mode 4 to 5, **Preheat** function is active immediately when the controller is switched on power.

During crank period, the **Preheat** relay output will not energise in any of above modes.

4.8 The function of forcing start:

Reason to add this function to the controller is that when the engine under abnormal conditions, e.g. the battery voltage is too low or ambient temperature is too low, or generator only outputs voltage at a high speed when magnetic pick-up is not used, the Genset cannot be started successfully when it implements the build-up cranking process of controller. There are 2 methods to solve these conditions in the controller:

First method: when controller is running in “MANUAL” mode, normally the crank time will not exceed the pre-set value, but you can press “START” button and hold without changing the related parameters until it has started, the crank time depends on the holding time on the button. Safety-on timer begins after it has successfully started. The other processes and protections are the same as for a normal start.

Second method: when controller is running in “MANUAL” mode, configure the “**EX. Crank permit**” as “1”, shown as schematic below, a PB switch is externally mounted to control cranking. Close PB switch, engine cranks, when the speed reaches 150RPM or generator voltage output is not less than AC 20V if magnetic pick-up is not used, then controller functions are triggered, the fuel relay output is energised, safety-on timer begins after the speed reaches crank cutout value, the other processes and protections are the same as normal start. If the speed falls below 150RPM within safety-on time, controller will be reset and return to standby status.

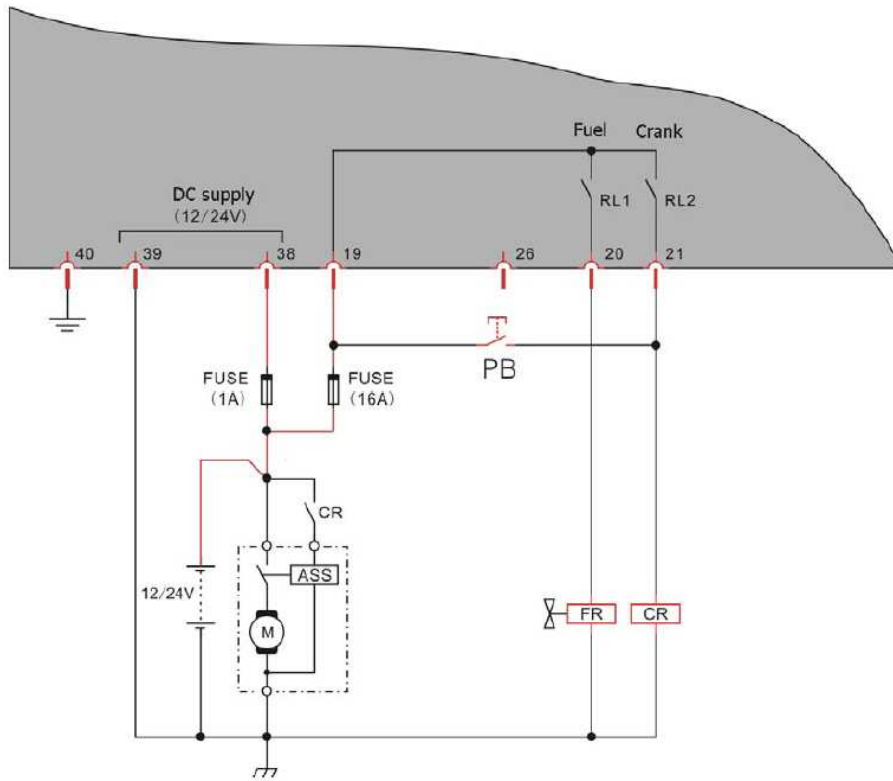

CAUTION:

- We normally don't recommend using the second method to solve this condition.
- Pay attention to the installation of PB switch to avoid cranking when the Genset is running.

4.9 Speed control for actuator motor (optional):

Controller with this speed control function controls the speed motor of engine and regulates the size of fuel via continuously output speed raise/ lower switch control signal with PID function, making engine's running speed stable within the setting range.

4.10 Flow chart for start and stop

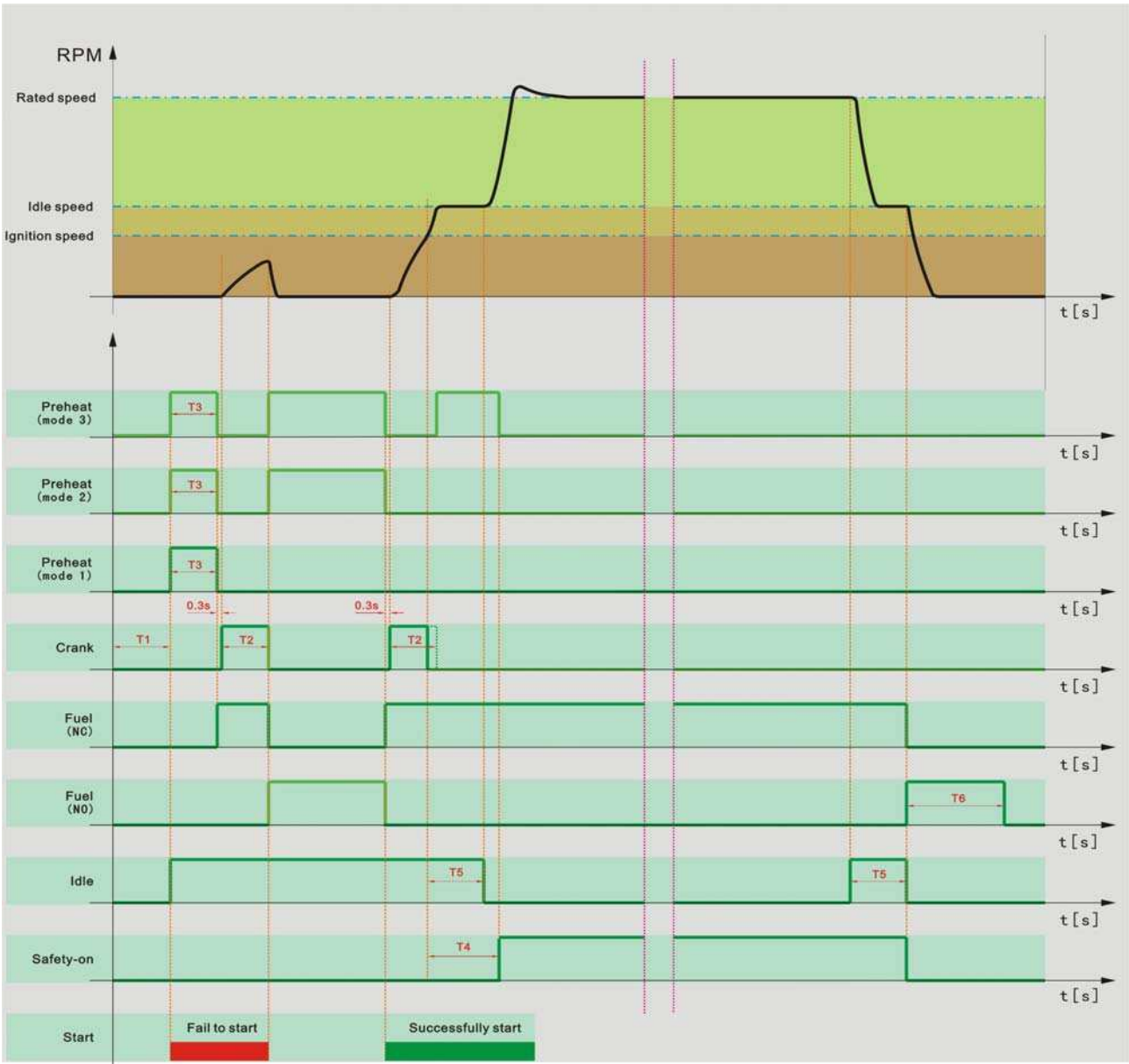

T1 - start delay

T2 - safety-on delay

T3 - crank time

T4 - idle time

T5 - pre-heat time

T6 - Stop delay



NOTE:

If T4 is longer than T5, oil pressure protection is ignored during T5.
 If T4 is shorter than T5, oil pressure protection becomes effective after T4 in T5.

5. Measure and Display Data

Gen VPh-N **L1-N L2-N L3-N**

Gen VPh-Ph **L1-L2 L2-L3 L3-L1**

Gen frequency **Hz** (L1)

Gen 3 phases current **I1 I2 I3**

Gen 3 phases apparent power **KVA AL1 AL2 AL3 ΣA**

Gen 3 phases active power **KW PL1 PL2 PL3 ΣP**

Gen 3 phases reactive power **KVAr QL1 QL2 QL3 ΣQ**

Gen 3 phases power factor **PFL1 PFL2 PFL3 PF(AV)**

Gen total active energy **(KWhr) ΣE**

Gen total reactive energy **(KVArhr) ΣE**

Engine speed **RPM** (signal derived from magnetic pick-up or generator Hz)

Engine oil pressure **Bar / PSI** (signal from engine LOP sensor)

Engine coolant temperature **°C/°F** (signal from engine HET sensor)

AUX. analog input #1

AUX. analog input #2

Battery voltage **Vdc**

Genset Running hour **Hour**

6. Warning and Shutdown Alarm

6.1 Pre-alarm (warning)

(NOTE: Pre-alarms are non-critical failure conditions and do not affect the operation of the generator system, they serve for drawing the operators' attention to an undesirable condition so they can remove it to ensure continuous running of the system. When Pre-alarms occur, the Pre-alarm LED illuminates, but failure will not be locked out and the unit will not shutdown. Once the Pre-alarm failure is removed the Pre-alarm LED will automatically turn off.)

Pre-alarm / Description	LCD displays
<p>CHARGE FAILURE: After safety-on times up, if the charging voltage from the excitation contact of alternator is lower than the "ALT. low preALM", the pre-alarm LED illuminates and the buzzer sounds, LCD displays:</p>	<p>WARN: CHARGE FAILURE</p>
<p>BATT. UNDER VOLT: If controller detects that battery voltage has fallen below the "Batt. Undervolt", pre-alarm LED illuminates and the buzzer sounds, LCD displays:</p>	<p>WARN: BAT. UNDER VOLT</p>
<p>BATT. OVER VOLT: If controller detects that battery voltage has exceeded the "Batt. overvolt", the pre-alarm LED illuminates and the buzzer sounds, LCD displays:</p>	<p>WARN: BAT. OVER VOLT</p>
<p>LOW OIL PRESS: If controller detects that the engine oil pressure has fallen below the "Oil-P low preALM" after the safety-on timer expired, the pre-alarm LED illuminates and the buzzer sounds, LCD displays:</p>	<p>WARN: LOW OILPRESS</p>
<p>HIGH TEMP: If controller detects that engine coolant temperature has exceeded the "Coolant preALM", the pre-alarm LED illuminates and the buzzer sounds, LCD displays:</p>	<p>WARN: HIGH TEMP.</p>
<p>OVER SPEED: If engine speed exceeds the "Over SP preALM", the pre-alarm LED illuminates and the buzzer sounds, LCD displays:</p>	<p>WARN: OVER SPEED</p>

<p>UNDER SPEED: If engine speed falls below the “Under SP preALM” after the safety-on timer has expired, the pre-alarm LED illuminates and the buzzer sounds, LCD displays:</p>	<p>WARN: UNDER SPEED</p>
<p>OVER CURRENT: configure “Overcurrent action” as “warning”, if controller detects that any phase output current exceeds the “Overcurrent level” after the safety-on timer has expired, the pre-alarm LED illuminates and the buzzer sounds, LCD displays:</p>	<p>WARN: OVER CURRENT</p>
<p>OVER FREQ: If controller detects that generator’s frequency has exceeded the “GEN-Hz over preALM” after the safety-on timer has expired, the pre-alarm LED illuminates and the buzzer sounds, LCD displays:</p>	<p>WARN: OVER FREQ.</p>
<p>UNDER FREQ: If controller detects that generator’s frequency has fallen below the “GEN-Hz under preALM” after the safety-on timer has expired, the pre-alarm LED illuminates and the buzzer sounds, LCD displays:</p>	<p>WARN: UNDER FREQ.</p>
<p>GEN. OVER VOLT: If controller detects that any phase output voltage of generator has exceeded the “GEN-V over preALM” after the safety-on timer has expired, the pre-alarm LED illuminates and the buzzer sounds, LCD displays:</p>	<p>WARN: GEN. OVER VOLT</p>
<p>GEN. UNDER VOLT: If controller detects that any phase output voltage of generator has fallen below the “GEN-V under preALM” after the safety-on timer has expired, the pre-alarm LED illuminates and the buzzer sounds, LCD displays:</p>	<p>WARN: GEN. UNDER VOLT</p>
<p>OVERLOAD: If controller detects that the active power of generator has exceeded the “KW Overload preALM” after the safety-on timer has expired, the pre-alarm LED illuminates and the buzzer sounds, LCD displays:</p>	<p>WARN: KW OVERLOAD</p>
<p>D-INPUT: If one of configurable D-inputs has been configured as pre-alarm, when D-input is active, the pre-alarm LED illuminates and the buzzer sounds, LCD displays:</p>	<p>WARN: D-INPUT *</p>

<p>AUX1 LOW LEVEL: when A-sensor 1 use and A-sen 1 under act. have been configured as “fuel level” and “pre-alarm”, if controller detects that the level has fallen below the “under level”, the pre-alarm LED illuminates and the buzzer sounds, LCD displays:</p>	<p>WARN: LOW FUEL LEVEL</p>
<p>If A-sensor 1 use has been configured as “temperature”, LCD displays:</p>	<p>WARN: AUX1 LOW TEMP.</p>
<p>AUX1 HIGH LEVEL: when A-sensor 1 use and A-sen 2 over act. have been configured as “fuel level” and “pre-alarm”, if controller detects that the level has exceeded the “over level”, the pre-alarm LED illuminates and the buzzer sounds, LCD displays:</p>	<p>WARN: HIGH FUEL LEVEL</p>
<p>If A-sensor 1 use has been configured as “temperature”, LCD displays:</p>	<p>WARN: AUX1 HIGH TEMP.</p>
<p>AUX2 LOW LEVEL: when A-sensor 2 use and A-sen 2 under act. have been configured as “temperature” and “pre-alarm”, if controller detects that the temperature has fallen below the “under level”, the pre-alarm LED illuminates and the buzzer sounds, LCD displays:</p>	<p>WARN: AUX2 LOW TEMP.</p>
<p>If A-sensor 2 use has been configured as “oil pressure”, LCD displays: (it is active after safety-on timer has expired)</p>	<p>WARN: AUX2 LOW PRES.</p>
<p>AUX2 HIGH LEVEL: when A-sensor 2 use and A-sen 2 over act. have been configured as “temperature” and “pre-alarm”, if controller detects that the temperature has exceeded “over level”, the pre-alarm LED illuminates and the buzzer sounds, LCD displays:</p>	<p>WARN: AUX2 HIGH TEMP.</p>
<p>ECU ALARM: When using J1939 CAN bus, if the failure detected by ECU, the controller will receive this information from the ECU immediately, the pre-alarm LED illuminates and the buzzer sounds, LCD displays:</p>	<p>WARN: ECU ALARM</p>
<p>GCB FAILURE: If GCB close/open relay is closed, the timer for GCB closing time is activated, when it times out, if the controller does not receive the feed back signal from Gen Aux. Switch’s contact, then Gen fail to load alarm is activated. The GCB closed LED flashes and the buzzer sounds, LCD displays:</p>	<p>WARN: GCB FAILURE</p>



NOTE:

- Controller continuously detects battery voltage during standby period and **Battery Under/Over Voltage** Pre-alarms are active.
- **Battery under** Voltage pre-alarm is inactive during cranking.



CAUTION:

Under the period of safety-on delay, some pre-alarms (e.g.: under speed, under voltage, low oil pressure) are inactive, the safety-on time must be carefully and properly set to make Genset have full protection.



NOTE:

To make the pre-alarm for **GCB FAILURE** active, please configure one of the configurable inputs as **Gen Aux. Switch Closed** and connects the switch's N.O. Aux. contact to this port. After pre-alarm occurred, the controller is locked out, you must press reset button to remove.

6.2 Shutdown Alarm

(NOTE: shutdown alarm failures immediately lock out the system and stop the Genset. The failure must be removed and the controller reset before restarting the Genset.)

Shutdown Alarm / Description	LCD displays
START FAILURE: if engine does not fire after the preset number of crank attempt has been made, the Shutdown alarm LED illuminates and buzzer sounds, LCD displays:	ALARM: START FAILURE
STOP FAILURE: if engine does not stop after the Stop delay expired, the Shutdown alarm LED illuminates and buzzer sounds, LCD displays:	ALARM: STOP FAILURE
EMERGENCY STOP: Configure a configurable input as emergency stop, when the input signal is active, controller immediately stops all relay control outputs except alarm, Genset is shut down, the Shutdown alarm LED illuminates and buzzer sounds, LCD displays:	ALARM: E.STOP
LOW OIL PRESS: if controller detects that the oil pressure level still falls below "Oil-P low Alarm" or LOP switch closes after the safety-on timer has expired, engine stops immediately, the Shutdown alarm LED illuminates and buzzer sounds, LCD displays:	ALARM: LOW OILPRESS

<p>ENGINE HIGH TEMP: if controller detects that engine coolant temperature has exceeded the “Coolant Alarm” or HET switch closes, engine stops immediately, the Shutdown alarm LED illuminates and buzzer sounds, LCD displays:</p>	<p>ALARM: HIGH TEMP.</p>
<p>OVER SPEED: if controller detects that engine speed exceeds the “Over SP Alarm”, engine stops immediately, the Shutdown alarm LED illuminates and buzzer sounds, LCD displays:</p>	<p>ALARM: OVER SPEED</p>
<p>UNDER SPEED: if controller detects that engine speed falls below the “Under SP Alarm” after the safety-on timer has expired, engine stops immediately, the Shutdown alarm LED illuminates and buzzer sounds, LCD displays:</p>	<p>ALARM: UNDER SPEED</p>
<p>OVER CURRENT: configure “Overcurrent action” as “shutdown”, after safety-on delay times out, if controller detects that any phase output current is higher than “Overcurrent level”, the Genset will be shut down immediately, the Shutdown alarm LED illuminates and buzzer sounds, LCD displays:</p>	<p>ALARM: OVER CURRENT</p>
<p>OVER FREQ: if controller detects that Genset’s frequency exceeds the “GEN-Hz over Alarm” after the safety-on timer has expired, Genset stops immediately, the Shutdown alarm LED illuminates and buzzer sounds, LCD displays:</p>	<p>ALARM: OVER FREQ.</p>
<p>UNDER FREQ: if controller detects that Genset’s frequency falls below the “GEN-Hz under Alarm” after the safety-on timer has expired, Genset stops immediately, the Shutdown alarm LED illuminates and buzzer sounds, LCD displays:</p>	<p>ALARM: UNDER FREQ.</p>
<p>GEN. OVER VOLT: After safety-on delay times out, If controller detects that any phase output voltage of generator is higher than “GEN-V over Alarm”, Genset stops, the Shutdown alarm LED illuminates and buzzer sounds, LCD displays:</p>	<p>ALARM: GEN. OVER VOLT</p>
<p>GEN. UNDER VOLT: After safety-on delay times out, If controller detects that any phase output voltage of generator is lower than “GEN-V under Alarm”, Genset stops, the Shutdown alarm LED illuminates and buzzer sounds, LCD displays:</p>	<p>ALARM: GEN. UNDER VOLT</p>

<p>OVERLOAD: After safety-on delay times out, if controller detects the active power is higher than “KW Overload Alarm”, Genset stops, the Shutdown alarm LED illuminates and buzzer sounds, LCD displays:</p>	<p>ALARM: KW OVERLOAD</p>
<p>LOSS OF PICKUP: if magnetic pick-up is used, when the controller detects no signal from magnetic pickup during safety-on or idle period, Genset stops, the Shutdown alarm LED illuminates and buzzer sounds, LCD displays:</p>	<p>ALARM: LOSS OF PICKUP</p>
<p>LOP SENSOR OPEN: when controller detects that the resistance of LOP-sensor exceeds the range of measurement, it means LOP sensor open, Genset stops, the Shutdown alarm LED illuminates and buzzer sounds, LCD displays:</p>	<p>ALARM: P-SENSOR OPEN</p>
<p>ECU DATA FAIL: when using J1939 CAN bus, if controller detects no data from the ECU, Genset stops, the Shutdown alarm LED illuminates and buzzer sounds, LCD displays:</p>	<p>ALARM: ECU DATA FAIL</p>
<p>ECU SHUTDOWN: when the ECU detects a shutdown alarm and sends it to controller, the Shutdown alarm LED illuminates and buzzer sounds, LCD displays:</p>	<p>ALARM: ECU SHUTDOWN</p>
<p>LOW FUEL LEVEL: when A-sensor 1 use and A-sen 1 under act. have been configured as “fuel level” and “alarm”, if controller detects that the level has fallen below the “under level”, Genset stops immediately, the shutdown alarm LED illuminates and the buzzer sounds, LCD displays:</p>	<p>ALARM: LOW FUEL LEVEL</p>
<p>AUX1 HIGH TEMP.: when A-sensor 1 use and A-sen 1 over act. have been configured as “temperature” and “alarm”, if controller detects that the temperature has exceeded the “over level”, Genset stops, the shutdown alarm LED illuminates and the buzzer sounds, LCD displays:</p>	<p>ALARM: AUX1 HIGH TEMP.</p>
<p>AUX2 LOW LEVEL: when A-sensor 2 use and A-sen 2 under act. have been configured as “oil pressure” and “alarm”, if controller detects that the oil pressure has fallen below the “under level”, Genset stops immediately, the shutdown alarm LED illuminates and the buzzer sounds, LCD displays: (it is active after safety-on delay expired)</p>	<p>ALARM: AUX2 LOW PRES.</p>

<p>AUX2 HIGH LEVEL: when A-sensor 2 use and A-sen 2 over act. have been configured as “temperature” and “alarm”, if controller detects that the temperature has exceeded the “over level”, Genset stops immediately, the shutdown alarm LED illuminates and the buzzer sounds, LCD displays:</p>	<p>ALARM: AUX2 HIGH TEMP.</p>
--	--------------------------------------

**NOTE:**

If engine speed signal is derived from generator output voltage frequency, it is used for control and failure protection parameters, for convenience of user, some data is expressed by RPM, $RPM = HZ * 60 / \text{pair of poles}$.

**NOTE:**

While the Genset is running, if there is high coolant temperature, low oil pressure or over speed failure the controller will shutdown it immediately without delay. During the cool down period, if there is low oil pressure failure, the controller will shut down the Genset immediately without delay.

**CAUTION:**

During the period of safety-on delay, low oil pressure protection is inactive. To avoid starting an engine with no oil, you must make sure the oil levels are normal and the safety-on time shall be carefully and properly set for the first commissioning.

7. Parameters Setting

7.1 SYSTEM:

NO.	Items	Preset	Value Range
1.1	CT Ratio	1000:5	5:5 to 30000:5
1.2	VT Ratio	1.0:1	1.0:1 to 100.0:1
1.3	Rated ph-Voltage	220	1 to 30000VAC
1.4	Rated current	1000	1.0 to 30000A
1.5	Rated active power	500	1.0 to 16000KW
1.6	Voltage Type	1	1 to 5
1.7	Comm. Address	1	1 to 247
1.8	Startup mode	0	0 MAN/ 1 AUTO/ 2 the same as last time
1.9	Press Unit	0	0Bar / 1PSI
1.10	Temperature Unit	0	0°C / 1°F
1.11	Send SMS count	not used	1 to 99 times / not used
1.12	Telephone 1 NO.	000000000000	
1.13	Telephone 2 NO.	000000000000	
1.14	Telephone 3 NO.	000000000000	
1.15	Default settings		
1.16	Language		
1.17	Password		0000 to 9999
1.18	Engine ECU type	not used	1 to 20 / not used
1.19	Display contrast	5	1 to 9%
1.20	Auto scroll time	not used	1 to 60s / not used
1.21	Firmware update		

Menu descriptions:

CT Ratio:

- The current is derived from CT on generator or load.
- Secondary current on CT is fixed at 5A.
- Used to calculate for GEN: KVA, KW, KVA_r, PF, KW_{hr}, KVA_{rhr}.
- Used for shutdown alarm: overcurrent, overload, etc.

VT Ratio:

- The voltage is derived from VT on Gen and Mains.
- Used to detect frequency of Gen and Mains.
- Used to calculate for GEN: KVA, KW, KVA_r, PF, KW_{hr}, KVA_{rhr}.
- Used for shutdown alarm: over/under voltage, overload, etc.

Rated ph-voltage:

- Used to define the rated voltage (phase to neutral) of Gen and Mains, rated V_{Ph-Ph} = "Rated phvoltage"* 1.732
- Reference value for judging over/under voltage.

Rated current:

- Used to define the rated current of generator.
- Reference value for judging over current.

Voltage type:

- There are 5 kinds of voltage type: “Y” 3P4W, “ Δ ” 3P4W, 3P3W, 1P3W, 1P2W.
- “Y” 3P4W (3 phases 4 wires star):

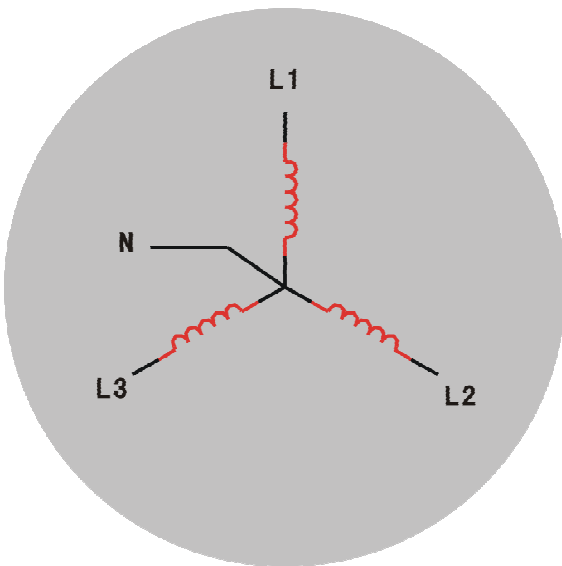
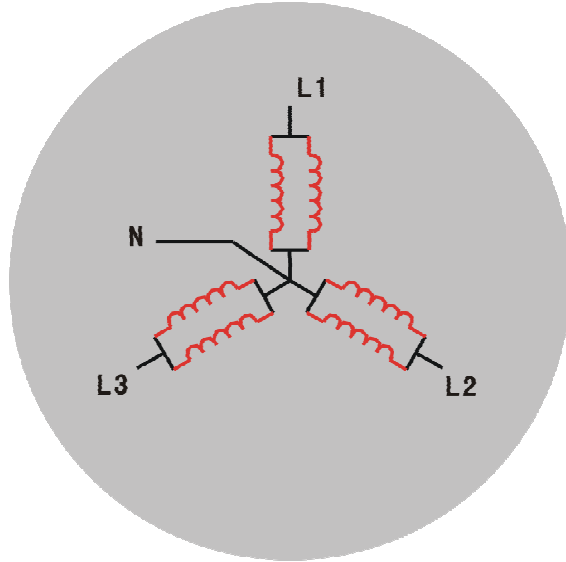
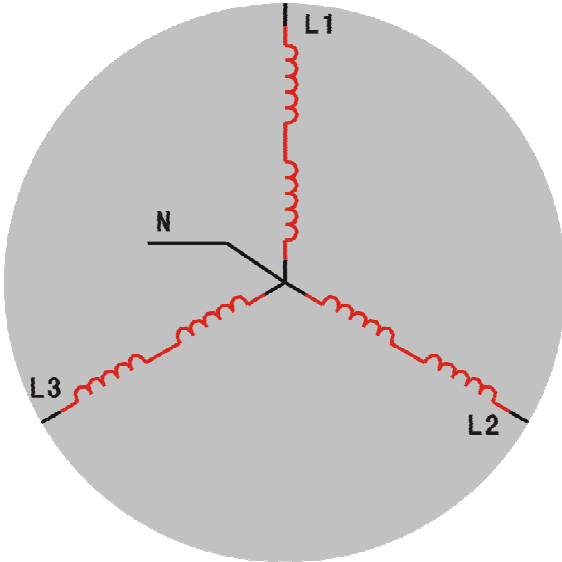

2—"△" 3P4W (3 phases 4 wires angle):

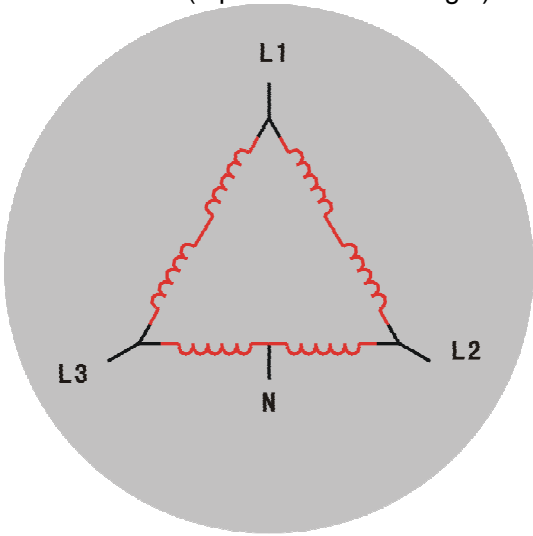

3— 3P3W (3 phases 3 wires):

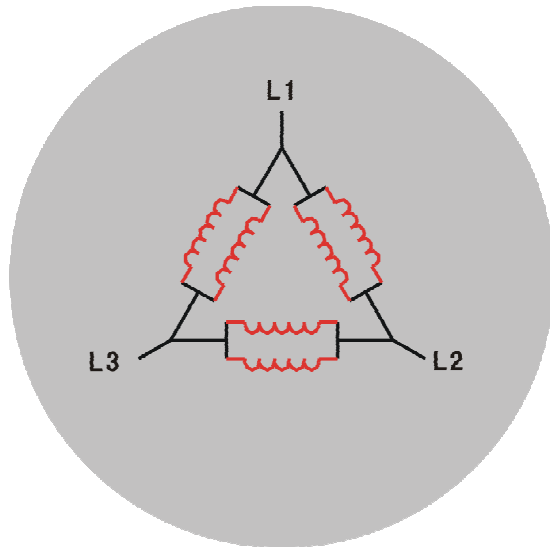
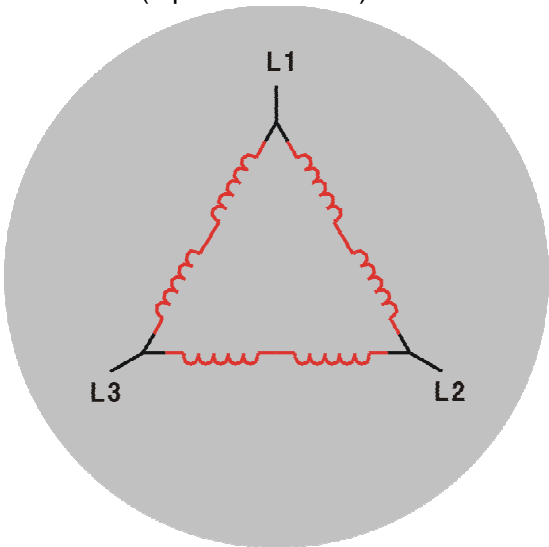

4— 1P3W (single phase 3 wires):

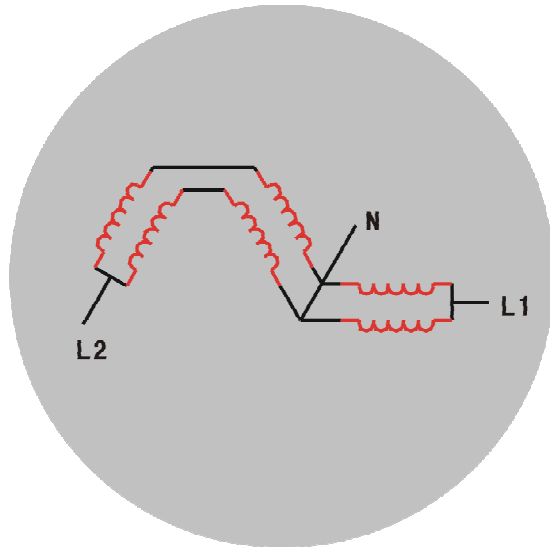
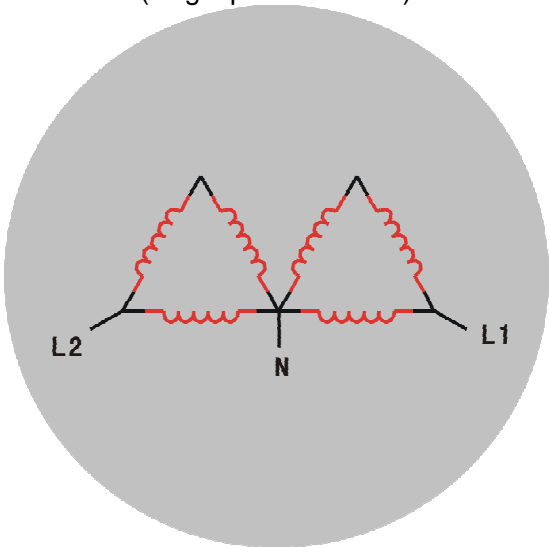

5— 1P2W (single phase 2 wires):

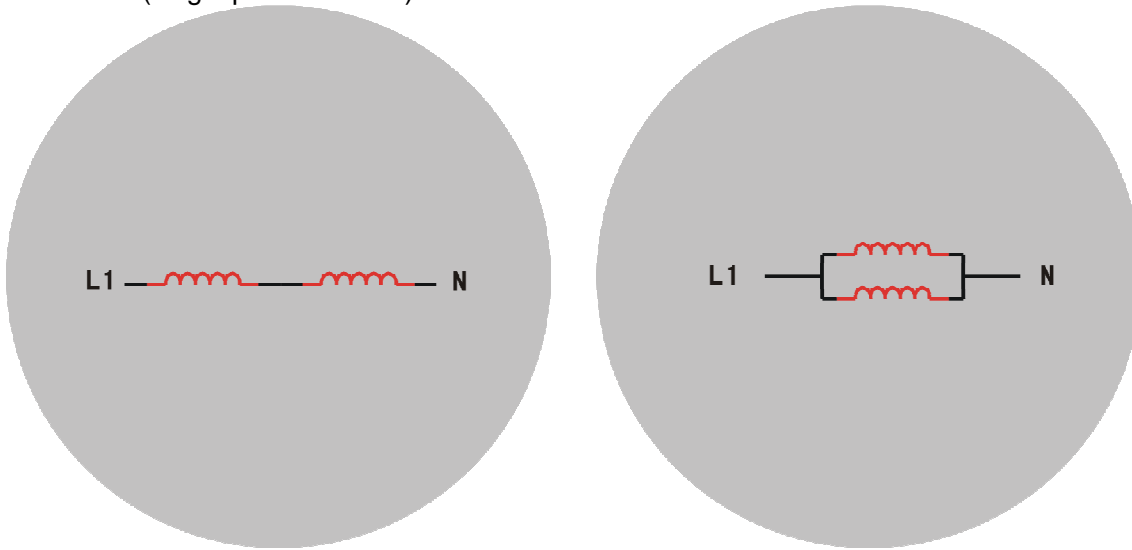
**Comm. Address:**

- Used to configure ID address for MODBUS
- Each controller on the same MODBUS has a unique communication address.

Startup mode:

- Used to configure the Startup mode of controller when it is powered up.
- When parameter is configured as “0”, the controller will be in Manual mode when it is powered up.
- When parameter is configured as “1”, the controller will be in Automatic mode when it is powered up.
- When parameter is configured as “2”, the controller will be in the mode which is the same as last time when it is powered up.

Press Unit:

- Used to define oil pressure unit which is displayed on the LCD. “0” stand for Bar, “1” stand for PSI.
- Transfer formula: $P[\text{psi}] = P[\text{bar}] * 14.503$.

Temperature Unit:

- Used to define temperature unit which is displayed on the LCD. “0” stand for °C, “1” stand for °F.
- Transfer formula: $T[^\circ\text{F}] = (T[^\circ\text{C}] * 1.8) + 32$.

Send SMS count:

- Used to activate the Text Message function and choose the quantity of text message.
- When parameter is configured as “not used”, the function of Text Message is inactive.
- To obtain the function of Text Message Service, equipped with GPRS-DTU module is required.

Telephone 1 NO.:

- Used to configure the mobile hone number which the Text Message will be sent to.
- There are total 3 mobile phone numbers can be configured .

Telephone 2 NO.:

- Same as above.

Telephone 3 NO.:

- Same as above.

Default settings:

- Some parameters are resumed to default setting.

Language:

- Used to select the Language which is displayed on the LCD.

Password:

- There are 3 levels of password (CL0/CL1/CL2) for different users.
- CL0 for the operator, who can read parameters, start and stop controller. The default setting is no password.
- CL1 for the technician, who has the authority of CL0 and can modify all parameters, the default setting is "2213".
- CL2 for factory, who have the authority of CL1 and Firmware update, the default setting as "3132".
- All passwords are automatically inactive 60 seconds after exiting menu.

Engine ECU type:

- Used to define the J1939 interface function and ECU type.
- There are several ECU types have been built in the controller.

Code	Description
1	Receive standard J1939 information
2	Standard J1939 information + specified VOLVO EMS2 information
3	Standard J1939 information + specified CUMMINS QSX15 information
4	CUMMINS(MODBUS) information

- To make the J1939 interface of controller active, external CANBUS module is required on ordering.

Display contrast:

- Used to adjust the display contrast of the LCD.

Auto scroll time:

- Used to configure the cycle of page scroll.
- When parameter is configured as "not used", manually scroll page via " " button.
- Start to scroll automatically 30 seconds after not pressing any button.

Firmware update:

- Used to load and update firmware for controller.
- It requires to key in CL2 password.

7.2 GENERATOR:

NO.	Items	Preset	Value Range
2.1	GEN-V under preALM	90%	20 to 200% / not used
2.2	GEN-V under Alarm	not used	20 to 200% / not used
2.3	GEN-V over preALM	115%	20 to 200% / not used
2.4	GEN-V over Alarm	not used	20 to 200% / not used
2.5	GEN-Hz under preALM	48.0Hz	10.0 to 100.0Hz / not used
2.6	GEN-Hz under Alarm	not used	10.0 to 100.0Hz / not used
2.7	GEN-Hz over preALM	55.0Hz	10.0 to 100.0Hz / not used
2.8	GEN-Hz over Alarm	57.0Hz	10.0 to 100.0Hz / not used
2.9	KW Overload preALM	not used	20 to 200% / not used
2.10	KW Overload Alarm	100%	20 to 200% / not used
2.11	Alarm delay	5s	0 to 600s
2.12	Overcurrent level	100%	20 to 200% / not used
2.13	Overcurrent delay	1	1 to 20s
2.14	Overcurrent action	0	0 warning/ 1 electrical trip/ 2 shutdown
2.15	Loading Voltage	95%	20 to 100%
2.16	Loading Frequency	48.0Hz	10.0 to 100.0Hz
2.17	GEN. ON Delay	5	1 to 9999s
2.18	GCB closing time	5	2 to 200s
2.19	Test mode	1	0 without load / 1 with load

Menu descriptions:

GEN-V under preALM:

- Used to configure Gen under voltage pre-alarm value, the GEN-V under preALM is inactive when parameter is configured as “not used”.
- Expressed by percentage, = “**Rated Ph-N voltage**” x ?%.

GEN-V under Alarm:

- Used to configure Gen under voltage alarm value, the GEN-V under Alarm is inactive when parameter is configured as “not used”.
- Expressed by percentage, = “**Rated Ph-N voltage**” x ?%.

GEN-V over preALM:

- Used to configure Gen over voltage pre-alarm value, the GEN-V over preAlarm is inactive when parameter is configured as “not used”.
- Expressed by percentage, = “**Rated Ph-N voltage**” x ?%.

GEN-V over Alarm:

- Used to configure Gen over voltage alarm value, the GEN-V over Alarm is inactive when parameter is configured as “not used”.
- Expressed by percentage, = “**Rated Ph-N voltage**” x ?%.

GEN-Hz under preALM:

- Used to configure Gen under frequency pre-alarm value, the GEN-Hz under preALM is inactive when parameter is configured as “not used”.

GEN-Hz under Alarm:

- Used to configure Gen under frequency alarm value, the GEN-Hz under Alarm is inactive when parameter is configured as “not used”.

GEN-Hz over preALM:

- Used to configure Gen over frequency pre-alarm value, the GEN-Hz over preALM is inactive when parameter is configured as “not used”.

GEN-Hz over Alarm:

- Used to configure Gen over frequency alarm value, the GEN-Hz over Alarm is inactive when parameter is configured as “not used”.

KW Overload preALM:

- Used to configure the over load pre-alarm value, the KW Overload preALM is inactive when parameter configured as “not used”.
- Expressed by percentage, use “**Rated active power**” as factor.

KW Overload Alarm:

- Used to configure the over load alarm value, the KW Overload Alarm is inactive when parameter configured as “not used”.
- Expressed by percentage, use “**Rated active power**” as factor.

Alarm delay:

Use a timer for confirmation of overcurrent alarm.

Overcurrent level:

- Used to configure the over current value of the Gen or the load, the over current alarm is inactive when parameter configured as “not used”.
- Expressed by percentage, use “**Rated current**” as factor.

Overcurrent delay:

- Use a timer for confirmation of over current alarm.

Overcurrent action:

- Used to configure the action which is implemented after overcurrent alarm confirmed.
- 3 types of parameters can be configured: 0 pre-alarm (warning)/1 electrical trip/2 shutdown.
- When parameter is configured as “0”, the pre-alarm (warning) LED illuminates and buzzer sounds if over current happen, and if the relative configurable relay defined as “over current pre-alarm (warning)”, then the relay output is energised, LCD displays: “warn: over current”.
- When parameter is configured as “1”, the pre-alarm(warning) LED illuminates and buzzer sounds if

over current happen, and if the relative configurable relay defined as “electrical trip”, then the relay output is energised, LCD displays: “warn: over current UnL”, the Genset will not be stopped.

- When parameter is configured as “2”, the shutdown alarm LED illuminates and buzzer sounds if over current happen, and if the relative configurable relay defined as “over current shutdown”, then the relay output is energised, and the Genset will be shut down, LCD displays: “alarm: over current”.

Loading Voltage:

- Used to configure the voltage trigger value of the GCB close.
- Expressed by percentage, use “**Rated ph-voltage**” as factor.

Loading Frequency:

- Used to configure the frequency trigger value of the GCB close.

GEN. ON delay:

- Use a timer for confirmation of voltage and frequency trigger value for Gen supply.

GCB closing time:

- Use a timer for confirmation of the Gen Aux. Switch’s contact has been closed.
- When the GCB output is energised, if the controller does not receive the feed back signal from the Gen Aux. Switch’s contact after the “GCB closing time” has expired, then means Gen fails to load.

Test mode:

- Used to select a function of the controller in the test mode.
- There are two test modes, one is “0 without load”, stand for test the Genset without load (the GCB close output will not be energised), another is “1 with load”, stand for test the Genset with load (the GCB close output will be energised).

7.3 ENGINE:

NO.	Items	Preset	Value Range
3.1	Rated speed	1500RPM	99 to 9999 RPM
3.2	MPU input	0	0 NO / 1 YES
3.3	Fly wheel teeth	120	5 to 300
3.4	Set pickup now		
3.5	Pair of Poles	2	1 to 4
3.6	Fuel mode	0	0 N.C. / 1 N.O.
3.7	T-sensor type	3	1 to 15 / not used
3.8	P-sensor type	4	1 to 15 / not used
3.9	Start delay	10s	0 to 300s
3.10	Crank attempt	3 times	1 to 10 times
3.11	Crank time	5s	1 to 30s
3.12	Crank time add	not used	1 to 30s / not used
3.13	Crank rest	10s	1 to 300s
3.14	Crank cutout RPM	300RPM	1 to 9999 RPM
3.15	Crank cutout volt	85%	1 to 100% / not used

3.16	Crank cutout ALT-V	not used	1.0 to 40.0V / not used
3.17	Crank cutout Oil-P	1.0Bar	0.1 to 150.0 Bar / PSI/ not used
3.18	Cutout P-delay	not used	1 to 60s / not used
3.19	Idle time	not used	1 to 9999s / not used
3.20	Pre-heat mode	1	1 to 5
3.21	Pre-heat time	3s	1 to 9999s / not used
3.22	Safety-on delay	10s	0 to 600s
3.23	Cool down mode	0	0 full speed / 1 idle
3.24	Cool down time	300s	0 to 600s
3.25	Stop delay	20s	0 to 60s
3.26	Under SP preALM	1440RPM	1 to 9999 RPM / not used
3.27	Under SP Alarm	not used	1 to 9999 RPM / not used
3.28	Over SP preALM	1600RPM	1 to 9999 RPM / not used
3.29	Over SP Alarm	1710RPM	1 to 9999 RPM / not used
3.30	Oil-P low preALM	1.4Bar	0.1 to 150.0 Bar / PSI/ not used
3.31	Oil-P low Alarm	1.1Bar	0.1 to 150.0 Bar / PSI/ not used
3.32	Coolant preALM	92°C	50 to 320°C / °F / not used
3.33	Coolant Alarm	100°C	50 to 320°C / °F / not used
3.34	Batt. Undervolt.	8.0V	1.0 to 40.0V / not used
3.35	Batt. overvolt.	28.0V	1.0 to 40.0V / not used
3.36	ALT. low preALM	8.0V	1.0 to 40.0V / not used
3.37	EX. Crank permit	0	0 NO / 1 YES

Menu descriptions:

Rated speed:

- Used to configure the Genset rated speed.
- A reference value for speed control.

MPU input:

- Used to configure whether magnetic pick-up unit is used or not.
- When parameter is configured as “1”, magnetic pick-up is used for the signal source of the engine speed. When parameter configured as “0”, the magnetic pick-up is not used, the engine speed is calculated from the frequency of the generator.
- $RPM = (Hz * 60) / \text{Pair of Poles}$. For example: the frequency of generator is 50Hz, when Pair of Poles configured as 2, $RPM = (50*60)/2 = 1500$ (RPM).

Fly wheel teeth:

- Used to configure there are how many teeth on the fly wheel.

Set pickup now:

- If user does not know the fly wheel teeth, to calculate the fly wheel teeth automatically via the measuring Gen frequency and MPU frequency.
- $\text{Fly wheel teeth} = (f1 * \text{Pair of Poles}) / f2$, {f1 is MPU frequency, f2 is Gen frequency}.

- Operating procedure:
 - Configure the parameter of “MPU input” as “0”.
 - Start the Genset, choose “Set pickup now” from the menu after the Genset running normally, the parameter of “fly wheel teeth” will be automatically calculated at that time.
 - Configure the parameter of “MPU input” as “1” to finish the setting.

**NOTE:**

This function is only used for the debug of the controller and Genset. Please do not implement this function when no RPM signal input.

Pair of Poles:

- Used to configure the poles of excitation winding of the alternator.
- Use to calculate the engine speed with the frequency when without MPU input.

Fuel mode:

- Used to configure the type of engine fuel valve (details refer to 4.5).
- N.C. type means the fuel channel is closed when fuel can not be used; N.O. type means the fuel channel is opened when fuel can not be used.

T-sensor type:

- Used to configure the type of HET sensor.
- Optional kinds of built-in HET sensors in the controller.

Code	Mode	Note
1	close for high temperature	
2	open for high temperature	
3	VDO 120°C	
4	VDO 150°C	
5	Datcon	
6	Murphy	
7	Pt100	
8	Pre-set 1	
9	Pre-set 2	
10	Pre-set 3	
11	Pre-set 4	
12	configurable 1	
13	configurable 2	
14	configurable 3	



CAUTION:

The HET sensor is used to measure the coolant temperature, its accuracy is very important to the protection of the Genset, so please match the right type of the sensor or configure the right curve of the sensor. Otherwise it may cause engine damage.

- The parameters appendix of HET sensor:

VDO 120°C :

T(°C)	40	50	60	70	80	90	100	110	120	130	140
T(°F)	104	122	140	158	176	194	212	230	248	266	284
R(Ω)	291	197	134	97	70	51	38	29	22	18	15

VDO 150°C :

T(°C)	50	60	70	80	90	100	110	120	130	140	150
T(°F)	122	140	158	176	194	212	230	248	266	284	302
R(Ω)	322	221	155	112	93	62	47	37	29	23	19

Datcon :

T(°C)	40	50	60	70	80	90	100	110	120	130	140
T(°F)	104	122	140	158	176	194	212	230	248	266	284
R(Ω)	900	600	400	278	200	141	104	74	50	27	4

Murphy :

T(°C)	40	50	60	70	80	90	100	110	120	130	140
T(°F)	104	122	140	158	176	194	212	230	248	266	284
R(Ω)	1029	680	460	321	227	164	120	89	74	52	40

PT100 :

T(°C)	-100	-50	0	20	40	60	80	100	150	200	300
T(°F)	-148	-58	32	68	104	140	176	212	302	392	572
R(Ω)	60	81	100	108	116	123	131	139	157	176	212

Pre-set 1:

T(°C)	20	30	40	50	60	70	80	90	100	110	120
T(°F)	68	86	104	122	140	158	176	194	212	230	248
R(Ω)	900	600	420	282	152	113	86	62	48	40	30

Pre-set 2:

T(°C)	30	50	60	70	80	90	100	110	120
T(°F)	86	122	140	158	176	194	212	230	248
R(Ω)	980	400	265	180	125	90	65	50	38

Pre-set 3:

T(°C)	20	30	40	50	60	70	80	90	100	110	120
T(°F)	68	86	104	122	140	158	176	194	212	230	248
R(Ω)	805	540	380	260	175	118	83	58	42	30	21

Pre-set 4:

T(°C)	28	35	40	50	60	70	80	90	95	98
T(°F)	82	95	104	122	140	158	176	194	203	208
R(Ω)	579	404	342	250	179	136	103	77	67	63



NOTE:

“Configurable” means user can input the data manually according to the sensor curve. Configurable 1 only can be set through the software; configurable 2 or 3 can be done through the push buttons on the front panel or software. When configuring, please input the “resistance-value” from small to big one by one.

P-sensor type:

- Used to configure the type of LOP sensor.
- Optional kinds of built-in LOP sensors in controller.

Code	Mode	Note
1	close for low oil pressure	
2	open for low oil pressure	
3	VDO 5 bar	
4	VDO 10 bar	
5	Datcon 7 bar	
6	Murphy 7 bar	
7	Pre-set 1	
8	Pre-set 2	
9	Pre-set 3	
10	Pre-set 4	
11	configurable 1	
12	configurable 2	
13	configurable 3	



CAUTION:

The LOP sensor is used to measure the oil pressure, its accuracy is very important to the protection of the Genset, so please match the right type of the sensor or configure the right curve of the sensor. Otherwise it may cause engine damage.

- The parameters appendix of LOP sensor:

VDO 5 bar :

P(Bar)	0	0.5	1.0	1.5	2.0	2.5	3.0	3.5	4.0	4.5	5
P(PSI)	0	7.3	14.5	21.8	29.0	36.3	43.5	50.8	58.0	65.3	72.5
R(Ω)	11	29	47	65	82	100	117	134	151	167	184

VDO 10 bar :

P(Bar)	0.0	1.0	2.0	3.0	4.0	5.0	6.0	7.0	8.0	9.0	10.0
P(PSI)	0	14.5	29.0	43.5	58.0	72.5	87.0	101.5	116.0	130.5	145.0
R(Ω)	10	31	52	71	90	106	124	140	155	170	184

Datcon 7 bar :

P(Bar)	0.0	0.7	1.4	2.1	2.8	3.4	4.1	4.8	5.5	6.2	6.9
P(PSI)	0	10.0	20.0	30.0	40.0	50.0	60.0	70.0	80.0	90.0	100.0
R(Ω)	240	200	165	135	115	95	78	63	48	35	25

Murphy 7 bar :

P(Bar)	0.0	0.7	1.4	2.1	2.8	3.4	4.1	4.8	5.5	6.2	6.9
P(PSI)	0	10.0	20.0	30.0	40.0	50.0	60.0	70.0	80.0	90.0	100.0
R(Ω)	240	205	171	143	123	103	88	74	60	47	33

Pre-set 1 :

P(Bar)	0.0	1.0	2.0	3.0	4.0	5.0	6.0	7.0	8.0	9.0	10.0
P(PSI)	0	14.5	29.0	43.5	58.0	72.5	87.0	101.5	116.0	130.5	145.0
R(Ω)	15	31	49	66	85	101	117	132	149	164	178

Pre-set 2 :

P(Bar)	0.0	1.0	2.0	3.0	4.0	5.0	6.0	7.0	8.0	9.0	10.0
P(PSI)	0	14.5	29.0	43.5	58.0	72.5	87.0	101.5	116.0	130.5	145.0
R(Ω)	30	41	65	88	110	115	145	150	172	185	190

Pre-set 3 :

P(Bar)	0	1.7	3.4	5.2	6.9	8.6	10.3
P(PSI)	0	25	50	75	100	125	150
R(Ω)	21	36	52	72	84	100	120

Pre-set 4 :

P(Bar)	1.0	2.0	3.0	4.0	5.0	6.0	7.0	8.0	9.0
P(PSI)	14.5	29.0	43.5	58.0	72.5	87.0	101.5	116.0	130.5
R(Ω)	195	155	127	107	88	72	61	54	48

NOTE:



“Configurable” means user can input the data manually according to the sensor curve. Configurable 1 only can be set through the software; configurable 2 or 3 can be done through the push buttons on the front panel or software. When configuring, please input the “resistance- measured value” from small to big one by one.

Start delay:

- Used to configure the time delay from the remote start signal is active to crank output is energised.

Crank attempt:

- Used to configure how many times the controller repeat to crank the engine; this value is equal to the maximum crank times.

Crank time:

- Used to configure the maximum time permit of engine cranking.

Crank time add:

- Used to adjust the maximum time permit of the repeat cranking.
- The second time of crank time is equal to the first crank time plus the extra time. For example: “crank time” set at 5s, “Crank time add” set at 3s, then since the second crank, the maximum crank time permit is 8s.

**CAUTION:**

The maximum crank time permit can not exceed the range of the equipment safety.

Crank rest:

- The time between last crank and next crank.
- Engine only can be cranked again after the crank rest time has expired.

Crank cutout RPM:

- The crank cutout speed.

Crank cutout volt:

- The crank disconnect voltage
- Expressed by percentage, use "Rated ph-voltage" as factor.

Crank cutout ALT-V:

- The crank cutout Charger voltage, signal is from the W/L terminal of charger.
- When parameter is configured as "not used", this function is inactive.

Crank cutout Oil-P:

- The crank cutout engine oil pressure, signal is from LOP-sensor.
- When parameter is configured as "not used", this function is inactive.

Crank cutout P-delay:

- Used to configure the period from engine LOP-switch opened or oil pressure reaches oil Pressure Crank cutout value to crank disconnection.
- When parameter is configured as "not used", this function is inactive, also both being the condition of judging stop failure and can not implement crank process are inactive.

Idle time:

- The duration of engine idle running.
- When you choose the idle mode, the configurable relay defined as idle output is energised, idle timer begins after start successfully, and the relay recovers to open after the idle time has expired.
- When parameter is configured as "not used", idle function is inactive.

Pre-heat mode:

- Used to configure the mode of preheat.
- There are 5 pre-heat modes for selection, please read the description of 4.7 preheat function for details.

Pre-heat time:

- The preheat duration before engine crank.
- When parameter is configured as "not used", pre-heat function is inactive.

Safety-on delay:

- Used to configure the period from engine started successfully to Genset stable running.
- The protection of under speed, under voltage, under frequency, low oil pressure is disabled by the controller during safety-on time delay.

**CAUTION:**

As some of the protection are disabled during safety-on time delay, so the safety-on delay should be set carefully and properly, this is very important, or it may cause engine damage.

Cool down mode:

- Used to configure the mode of cool down.
- When parameter is configured as “full speed”, the engine will run at rated speed during cooling down. When parameter is configured as “idle”, the engine will run in idle during cooling down.

Cool down time:

- The time permit for running without load before engine stop.
- It is necessary to set cool down time, it can make the engine stop at a lower temperature after a long time running with load.

Stop delay:

- The maximum time permit for the engine stop.
- After the fuel relay output is de-energised (fuel relay output is energised for N.O. type fuel valve), fail to stop delay timer begins, when it time's out if controller detects generator's voltage exceeds crank cutout voltage, or the speed exceeds crank cutout RPM, or LOP switch is open, or oil pressure exceeds crank cutout oil pressure, then stop failure occurs.
- If the fuel valve is N.O. type, the fuel relay output is de-energised after Stop delay has expired.

Under SP preALM:

- Used to configure the under speed pre-alarm value for the engine.

Under SP Alarm:

- Used to configure the under speed alarm value for the engine.

Over SP preALM:

- Used to configure the over speed pre-alarm value for the engine.

Over SP Alarm:

- Used to configure the over speed alarm value for the engine.

Oil-P low preALM:

- Used to configure the low oil pressure pre-alarm for the engine.
- The signal is derived from the LOP sensor, this function would be inactive if do not use the LOP sensor.
- This function is active after safety-on delay.

- If this parameter is configured as “not used”, the function would be inactive.

Oil-P low Alarm:

- Used to configure the under oil pressure alarm value for the engine.
- The signal is derived form the LOP sensor, this function would be inactive if do not use the LOP sensor.
- This function is active after safety-on delay.
- If this parameter is configured as “not used”, the function would be inactive.

Coolant preALM:

- Used to configure the high engine temperature pre-alarm value for the engine.
- The signal is derived form the HET sensor, this function would be inactive if do not use the HET sensor.
- If this parameter is configured as “not used”, the function would be inactive.

Coolant Alarm:

- Used to configure the high engine temperature alarm value for the engine.
- The signal is derived form the HETsensor, this function would be inactive if do not use the HET sensor.
- If this parameter is configured as “not used”, the function would be inactive.

Batt. Undervolt.:

- Used to configure the low battery voltage pre-alarm.
- If this parameter is configured as “not used”, the function would be inactive.

Batt. overvolt.:

- Used to configure the high battery voltage pre-alarm
- If this parameter is configured as “not used”, the function would be inactive.

ALT. low preALM:

- Used to configure the low charger voltage value.
- Voltage signal is derived from the excitation winding of charger.
- If this parameter is configured as “not used”, the function would be inactive.

EX. Crank permit:

- Used to configure the permit of external crank.
- Refer to 4.8 for details.

7.4 Configurable Inputs and Outputs:

NO.	Items	Preset	Value Range
4.1	D-Input 1	5	1 to 20 / not used
4.2	D-Input 2	6	1 to 20 / not used
4.3	D-Input 3	7	1 to 20 / not used
4.4	D-Input 4	9	1 to 20 / not used
4.5	D-Input 5	10	1 to 20 / not used
4.6	D-Input 6	11	1 to 20 / not used
4.7	D-Input 7	13	1 to 20 / not used
4.8	D-Input 1 delay	0	0 to 60s
4.9	D-Input 2 delay	0	0 to 60s
4.10	D-Input 3 delay	0	0 to 60s
4.11	D-Input 4 delay	0	0 to 60s
4.12	D-Input 5 delay	0	0 to 60s
4.13	D-Input 6 delay	0	0 to 60s
4.14	D-Input 7 delay	0	0 to 60s
4.15	A-sensor 1 use	1	1 fuel level/ 2 temp/ 3 Oil-P / not used
4.16	A-sensor 1 type	1	1 to 15
4.17	Fuel pump ON	20%	0 to 100%
4.18	Fuel pump OFF	70%	0 to 100%
4.19	A-sen1 under level	not used	fuel level: 0 to 100% temp: -20 to 320°C / °F Oil-P: 0.1 to 150.0 Bar / PSI / not used
4.20	A-sen1 under act.	0	0 pre-alarm/ 1 alarm/ 2 control
4.21	A-sen1 over level	not used	fuel level: 0 to 100% temp: -20 to 320°C / °F Oil-P: 0.1 to 150.0 Bar / PSI / not used
4.22	A-sen1 over act.	0	0 pre-alarm/ 1 alarm/ 2 control
4.23	A-sensor 2 use	1	1 preheat/ 2 temp/ 3 Oil-P / not used
4.24	A-sensor 2 type	3	1 to 15
4.25	Pre-heat ON	20°C	-20 to 320°C / °F
4.26	Pre-heat OFF	70°C	-20 to 320°C / °F
4.27	A-sen2 under level	not used	temp: -20 to 320°C / °F Oil-P: 0.1 to 150.0 Bar / PSI / not used
4.28	A-sen2 under act.	0	0 pre-alarm/ 1 alarm/ 2 control
4.29	A-sen2 over level	not used	temp: -20 to 320°C / °F Oil-P: 0.1 to 150.0 Bar / PSI / not used
4.30	A-sen2 over act.	0	0 pre-alarm/ 1 alarm/ 2 control
4.31	User Relay 1	20	1 to 80 / not used
4.32	User Relay 2	19	1 to 80 / not used

4.33	User Relay 3	2	1 to 80 / not used
4.34	User Relay 4	3	1 to 80 / not used
4.35	User Relay 5	5	1 to 80 / not used

Menu descriptions:

D-Input*:

- There are 7 configurable digital inputs.
- Optional items as following:

Code	Optional Functions	Note
1	Pre-alarm (warning)	Low level is active. When it is active, pre-alarm LED illuminates and buzzer sounds, LCD displays: warning: D-input*
2	alarm	Low level is active. When it is active, generator stops, shutdown alarm LED illuminates and buzzer sounds, LCD displays: alarm: D-input*
3	Pre-alarm 1	Low level is active. When it is active after safety-on delay, pre-alarm LED illuminates and buzzer sounds, LCD displays: warning: D-input*
4	Alarm1	Low level is active. When it is active after safety-on delay generator stops, shutdown alarm LED illuminates and buzzer sounds, LCD displays: alarm: D-input*
5	LOP switch	low level is active
6	HET switch	low level is active
7	Emergency stop	low level is active
8	Emergency stop	high level is active (N.O. is active.)
9	Remote start signal	low level is active
10	Reserved	
11	Gen Aux. Switch closed	low level is active
12	Low fuel level switch	low level is active
13	Lamp test	low level is active
14	Under speed limit	low level is active
15	Over speed limit	low level is active
16	Air flap aux switch close	low level is active
17	Preheat	Low level is active. Used for preheat mode 4, as the condition of preheat relay output is energised or not.
18	Crisis mode	Low level is active. In crisis mode, all shutdown alarms are changed to pre-alarm (warning), it means the Genset would not be shutdown when shutdown alarm occurs.

D-Input* delay:

- Used to configure the timer for confirmation of the configurable digital input.

A-sensor 1 use:

- Used to configure the purpose of auxiliary sensor #1.
- If this parameter is configured as “not used”, the sensor and the relative function would be

inactive.

A-sensor 1 type:

- Used to configure the type of auxiliary sensor #1 from the built-in list of the sensor.
- If “A-sensor 1 use” is configured as “1” fuel level, controller would auto select the built-in list of the fuel level sensor; If the “A-sensor 1 use” is configured as “2” temperature, controller would auto select the built-in list of the temperature sensor; If the “A-sensor 1 use” is configured as “3” oil pressure, controller would auto select the built-in list of oil pressure sensor.

- Fuel level sensor selection

Code	Type	Note
1	Configurable 1	
2	Configurable 2	

- Enter data according to the curve of the fuel sensor, configurable 1 only can be set through the software, configurable 2 can be set through both the push button on the front panel and software.

Fuel pump ON:

- Used to configure the low fuel level value, the configurable relay output which is defined as “fuel pump control” would be energised if it reaches this value.
- To active this function, the “A-sensor 1 use” is required to define as “1” fuel level.

Fuel pump OFF:

- Used to configure the high fuel level value, the configurable relay output which is defined as “fuel pump control” would be de-energised if it reaches this value.
- To active this function, the “A-sensor 1 use” is required to define as “1” fuel level.

A-sen1 under level:

- Used to configure the under level value for auxiliary sensor #1.
- If this parameter is configured as “not used”, the function would be inactive.

A-sen1 under act.:

- Used to configure the response mode of the controller when the level of auxiliary sensor #1 falls below the under level value.
- There are 3 modes: 0 pre-alarm(warning)/ 1 alarm/ 2 control
 - “0” pre-alarm, when the level of auxiliary sensor #1 falls below the under level value, prealarm LED illuminates and buzzer sounds, LCD displays: WARNING: LOW FUEL LEVEL (or WARNING: A-sen.1 low temp).
 - “1” alarm, when the level of auxiliary sensor #1 falls below the under level value, the Genset stops, shutdown alarm LED illuminates and buzzer sounds, LCD displays: ALARM: LOW OIL PRESSURE.
 - “2” control, when the level of auxiliary sensor #1 falls below the under level value, the relative configurable relay output would be energised.

A-sen1 over level:

- Used to configure the over level value for auxiliary sensor #1.

- If this parameter is configured as “not used”, the function would be inactive.

A-sen1 over act.:

- Used to configure the response mode of controller when the level of auxiliary sensor #1 exceeds the over level value.
- There are 3 modes: 0 pre-alarm(warning)/ 1 alarm/ 2 control
 - “0” pre-alarm, when the level of auxiliary sensor #1 exceeds the over level value, pre-alarm LED illuminates and buzzer sounds, LCD displays: WARNING: HIGH FUEL LEVEL (or WARNING: A-sen.1 high temp).
 - “1” alarm, when the level of auxiliary sensor #1 exceeds the over level value, the Genset stops, shutdown alarm LED illuminates and buzzer sounds, LCD displays: ALARM: A-sen.1 high temp.
 - “2” control, when the level of auxiliary sensor #1 exceeds the over level value, the relative configurable relay output would be energised.

A-sensor 2 use:

- Used to configure the purpose of auxiliary sensor #2.
- If this parameter is configured as “not used”, the sensor and the relative function would be inactive.

A-sensor 2 type:

- Used to configure the type of auxiliary sensor #2 from the built-in list of the sensor.
- If “A-sensor 2 use” is configured as “1” preheat or “2” temperature, controller would auto select the built-in list of the temperature sensor; If the “A-sensor 2 use” is configured as “3” oil pressure, controller would auto select the built-in list of oil pressure sensor.

Pre-heat ON:

- Used to configure the under engine temperature value, the configurable relay output which is configured as “preheat” would be energised if it reaches this value.
- To active this function, the “A-sensor 2 use” is required to configure as “1” preheat.

Pre-heat OFF:

- Used to configure the high engine temperature value, the configurable relay output which is configured as “preheat” would be de-energised if it reaches this value.
- To active this function, the “A-sensor 2 use” is required to configure as “1” preheat.

A-sen2 under level:

- Used to configure the under level value for the auxiliary sensor #2.
- If this parameter is configured as “not used”, the function would be inactive.

A-sen2 under act.:

- Used to configure the response mode of controller when the level of auxiliary sensor #2 falls below the under level value.
- There are 3 modes: 0 pre-alarm(warning)/ 1 alarm/ 2 control
 - “0” pre-alarm, when the level of auxiliary sensor #2 falls below the under level value, the prealarm LED illuminates and buzzer sounds, LCD displays: WARNING: A-sen.2 low temp (or

WARNING: A-sen.2 low oil pressure).

- “1” alarm, when the level of auxiliary sensor #2 falls below the under level value, the Genset stops, shutdown alarm LED illuminates and buzzer sounds, LCD displays: ALARM: A-sen.2 low oil pressure.
- “2” control, when the level of auxiliary sensor #2 falls below the under level value, the relative configurable relay output would be energised.

A-sen2 over level:

- Used to configure the over level value for auxiliary sensor #2.
- If this parameter is configured as “not used”, the function would be inactive.

A-sen2 over act.:

- Used to configure the response mode of the controller when the level of auxiliary sensor #2 exceeds the over level value.
- There are 3 modes: 0 pre-alarm(warning)/ 1 alarm/ 2 control
 - “0” pre-alarm, when the level of auxiliary sensor #2 exceeds the over level value, pre-alarm LED illuminates and buzzer sounds, LCD displays: WARNING: A-sen. 2 high temp.
 - “1” alarm, when the level of auxiliary sensor #2 exceeds the over level value, the Genset stops, shutdown alarm LED illuminates and buzzer sounds, LCD displays: ALARM: A-sen. 2 high temp.
 - “2” control, when the level of auxiliary sensor #2 exceeds the over level value, the relative configurable relay output would be energised.

User relay *:

- There are 5 configurable output relays.
- Optional functions as following:

Code	Alarm mode defined
0	not used
1	Over current trip
2	Common alarm
3	Common pre-alarm (warning)
4	Idle relay N.C.
5	Preheat relay
6	Speed up
7	Speed down
8	Fuel pump control
9	GEN. running
10	Auto mode
11	Test mode

12	Manual mode
13	Reserved
14	Idle relay N.O.
15	Reserved
16	GCB failure
17	Start failure
18	Stop failure
19	Reserved
20	GCB close/open
21	KW overload pre-alarm
22	Charge failure
23	Over current pr-alarm
24	Battery Under voltage
25	Battery Over voltage
26	Under frequency pre-alarm
27	Over frequency pre-alarm
28	Low oil press pre-alarm
29	Engine high temperature pre-alarm
30	Under speed pre-alarm
31	Over speed pre-alarm
32	GEN. under voltage pre-alarm
33	GEN. over voltage pre-alarm
34	A-sen1 under level
35	A-sen1 over level
36	A-sen2 under level
37	A-sen2 over level
38	ECU alarm
39	ECU alarm shutdown
40	Over current alarm
41	ECU data fail

42	Low oil pressure alarm
43	High Engine temperature alarm
44	Under speed alarm
45	Over speed alarm
46	Under frequency alarm
47	Over frequency alarm
48	GEN. under voltage alarm
49	GEN. over voltage alarm
50	KW overload alarm
51	LOP-Sensor open alarm
52	Configurable D-input 1 active
53	Configurable D-input 2 active
54	Configurable D-input 3 active
55	Configurable D-input 4 active
56	Configurable D-input 5 active
57	Configurable D-input 6 active
58	Configurable D-input 7 active
59	Buzzer sounds alarm
60	Air flap control
61	Reserved
62	Test without load mode
63	Test with load mode
64	Emergency stop
65	Reserved
66	Cooling down

**NOTE:**

If configure one of configurable digital output as speed up/down, after the engine started successfully, the controller can output a PID signal to the actuator motor for raising/lower the speed of engine, so that the speed of the engine will be stable in a setting range.

7.6 SPEED CONTROL

NO.	Items	Preset	Value Range
6.1	Proportional gain	10.0	0.1 to 100.0
6.2	Integral gain	1.0s	0.1 to 100.0s
6.3	Derivative ratio	1.0s	0.1 to 100.0s
6.4	Deadband	0.2Hz	0.1 to 9.9Hz
6.5	Time pulse minimum	0.2s	0.1 to 2.0s
6.6	Raise rate	5% / s	1 to 100% / s
6.7	Lower rate	5% / s	1 to 100% / s

Menu descriptions:

Proportional gain:

- Used to configure the P section of PID signal.
- Increase proportional gain will increase the response range of speed governing control, the larger response range the larger governing error. Maybe cause over speed if parameter is configured too large.

Integral gain:

- Used to configure the I section of PID signal.
- Integral gain will auto modify all offset and smoothly control. The factor of integral gain must bigger than derivative's. Genset will continue oscillation if the factor of integral gain too big, Genset will need a long time to go into stable status if the factor of integral gain too small.

Derivative ratio:

- Used to configure the D section of PID signal.
- The stability of governing system can be better via increasing this parameter.

Deadband:

- Controller will not output the PID signal to raise and lower the speed if the difference between engine speed and rated speed is within the range of this parameter.

Time pulse minimum:

- Used to configure the minimum time of PID signal output each time, means the minimum closing time of the relay each time.

Raise rate:

- Used to configure the increase rate of the frequency (per second) during governing.

Lower rate:

- Used to configure the decrease rate of the frequency (per second) during governing.

**NOTE:**

- All above parameters are used for speed control.
- Speed control function is an optional function on ordering; the parameters above are inactive without order.

7.7 CALIBRATION MENU

NO.	Items	Preset	Value Range
7.1	GEN. V1 offset		-9.9% to 9.9%
7.2	GEN. V2 offset		-9.9% to 9.9%
7.3	GEN. V3 offset		-9.9% to 9.9%
7.4	Current I1 offset		-9.9% to 9.9%
7.5	Current I2 offset		-9.9% to 9.9%
7.6	Current I3 offset		-9.9% to 9.9%
7.7	Pressure offset		-9.9% to 9.9%
7.8	Temperature offset		-9.9% to 9.9%
7.9	Batt. V offset		-9.9% to 9.9%
7.10	AUX sensor1 offset		-9.9% to 9.9%
7.11	AUX sensor2 offset		-9.9% to 9.9%

Menu descriptions:**GEN. V1 offset:**

- Used to modify the measured value display of GEN Phase 1 voltage.
- Reference to the Rated ph-voltage.

GEN. V2 offset:

- Used to modify the measured value display of GEN Phase 2 voltage.
- Reference to the Rated ph-voltage.

GEN. V3 offset:

- Used to modify the measured value display of GEN Phase 3 voltage.
- Reference to the Rated ph-voltage.

Current I1 offset:

- Used to modify the measured value display of Phase 1 current I1.
- Reference to the Rated current.

Current I2 offset:

- Used to modify the measured value display of Phase 2 current I2.
- Reference to the Rated current.

Current I3 offset:

- Used to modify the measured value display of Phase 3 current I3.
- Reference to the Rated current.

Pressure offset:

- Used to modify the measured value display of LOP-sensor.

Temperature offset:

- Used to modify the measured value display of HET-sensor.

Batt. V offset:

- Used to modify the measured value display of battery voltage.

AUX. sensor1 offset:

- Used to modify the measured value display of auxiliary sensor #1.

AUX. sensor2 offset:

- Used to modify the measured value display of auxiliary sensor #2.

8. Installation Guide

8.1 The cutout dimensional drawing installed on panel as above follows:

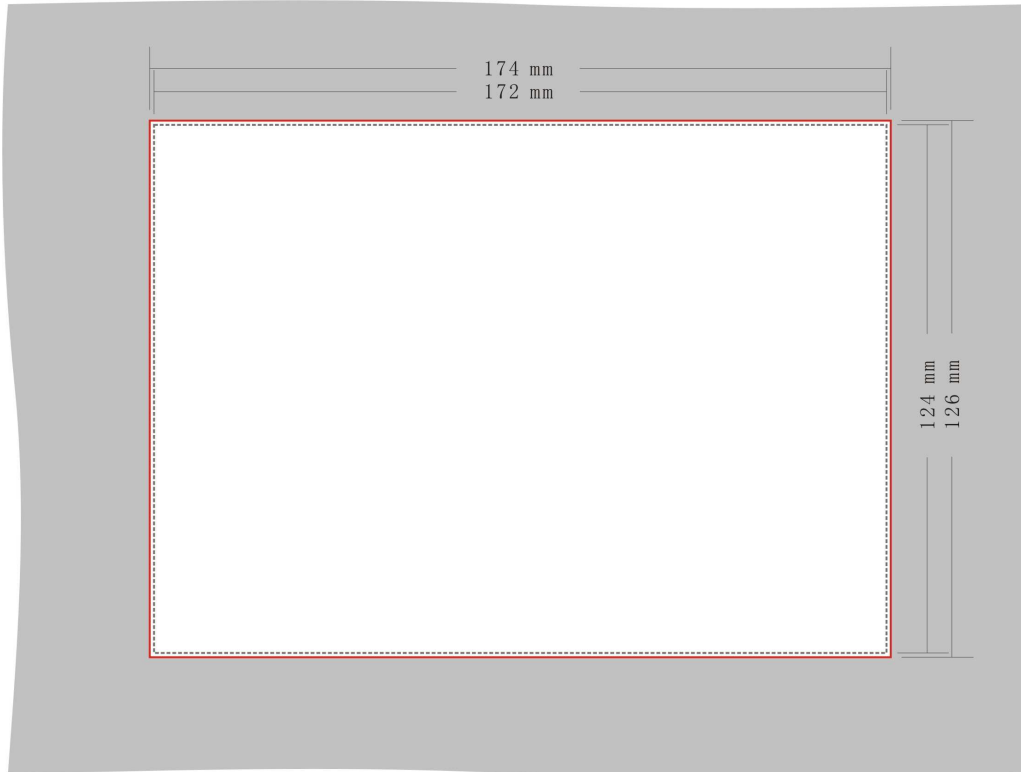

Cutout dimension: 174mm (W) x 126mm (H).

The controller is fixed by 6 special fittings.

**NOTE:**

- The shock-proof equipment must be mounted if the enclosure is mounted on Genset or other heavy vibrant device.
- In order to ensure the degrees of protection of the mounted controller meet
 - IP65, the cutout dimension on the panel must be correct.

8.2Wiring

Please refer to the above 2.3 Typical Wiring Diagram for connection.

8.2.1Grounding Protection:

Make sure the connection between terminal #40 of controller and protective earth is good, the cross section area of cable should not be less than 2.5mm².

**CAUTION:**

A good ground is very important for operation of controller, otherwise it will impact the electrical measurement and even damage the controller.

8.2.2 Power supply:

Power specification:

DC voltage range	8-35Vdc continuous
Max. operating current	@12V 310 mA , @24V 155mA
Cranking dropouts	0V for 80ms, assuming dc supply was at least 10V before dropout and recovers to 5V, controller can be normally operated dispenses with additional aux power.



NOTE:



- A switch or fuse for over current protection between power supply and controller must be mounted, the recommended capacity is 1A.
- When powering, the controller will generate significant instantaneous peak current, the maximum instantaneous peak current is relative to the power impedance. You must consider the peak current when choosing a switch or fuse for over current protection.

8.2.3 The installations of LOP sensor, HET sensor, and Auxiliary sensor:

The connection for 2 poles sensor:

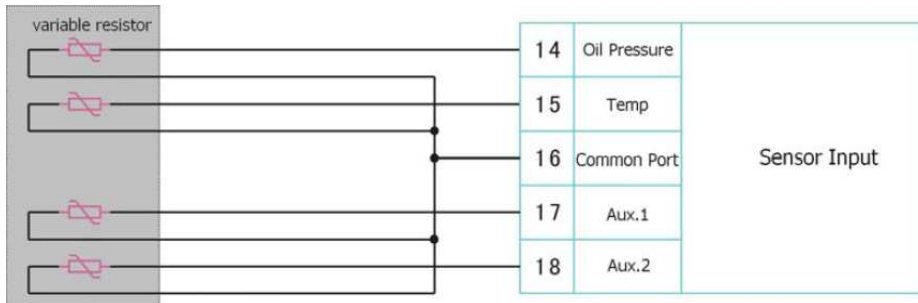

The connection for single pole sensor:

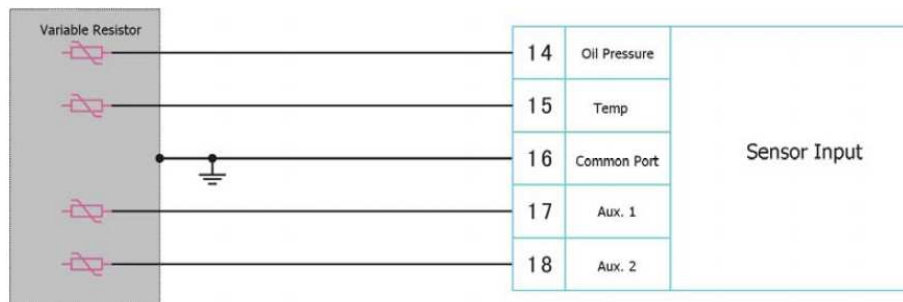

The connection for single pole / 2 poles sensor:

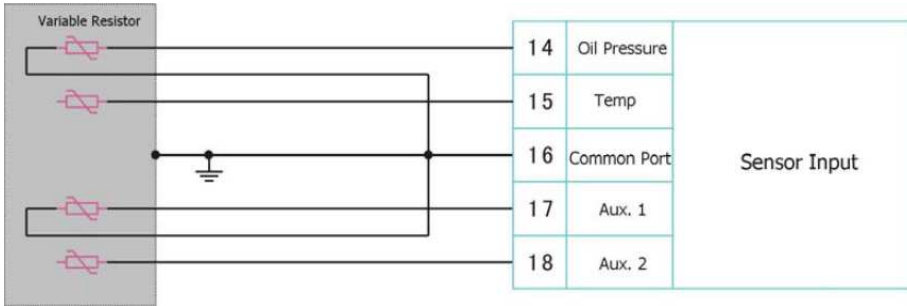

NOTE:



- For ensuring the accuracy of sensor please reduce the cable resistance between controller and sensor as much as possible, the cross section area of cable should not be less than 2.5mm².
- When single pole sensor is used, the terminal #16 must be directly connected to the generator's earth point, but not to the control panel or other earth point. It will impact the accuracy of sensor if the common port is connected to the power supply negative.
- The sensor shell and engine must be well connected and do not use insulated material on sensor screw thread when installing single pole sensor.

8.2.4 The installation of MPU:

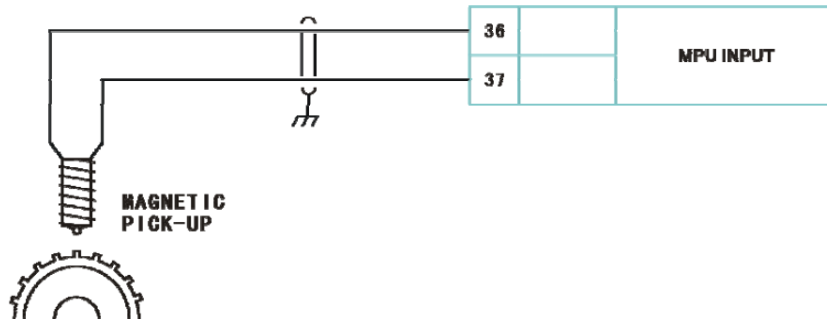

NOTE:



The measuring accuracy of magnetic pick-up is related to fly wheel teeth:
 Accuracy = $\pm (120 / \text{fly wheel teeth}) \text{ RPM}$ As the above formula, more fly wheel teeth leads to higher measuring accuracy.

NOTE:



- Shield cable must be used for connection between controller and sensor, and the shield should be earthed.
 Please pay attention that the terminal #37 is connected to negative of the power supply inside the controller.

8.2.5 Typical connection for voltage input and current that corresponding to difference generator winding:

3P4W (3 phases 4 wires)

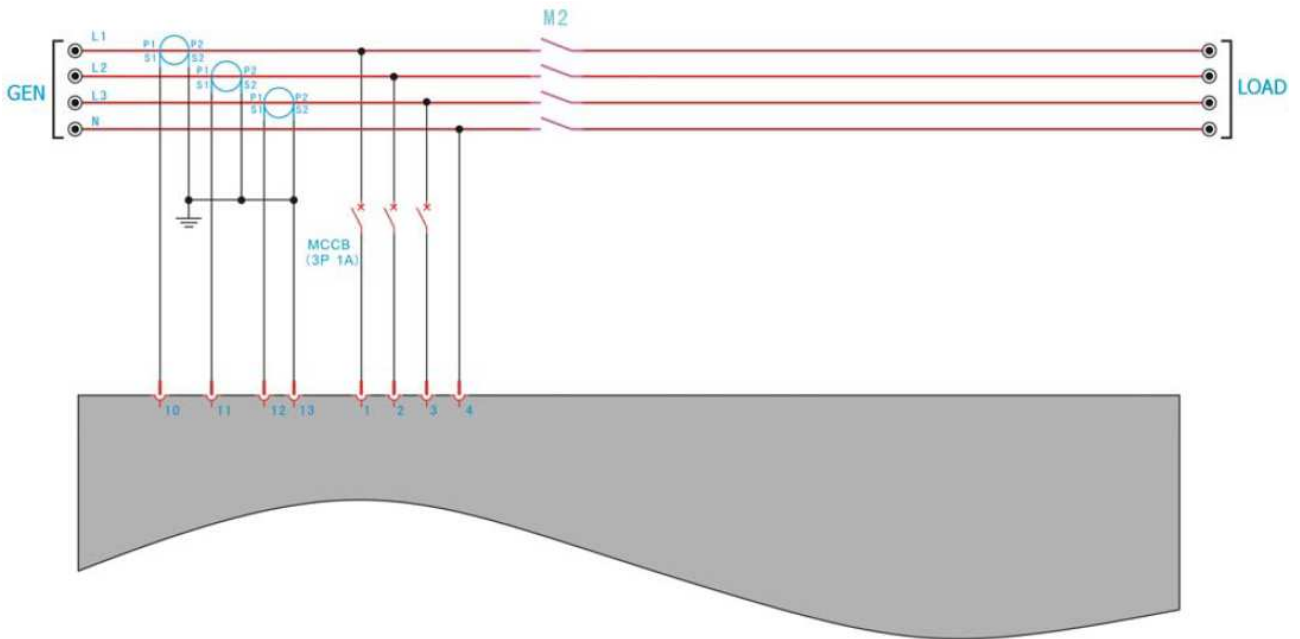

Measure and Display Data	
“Y” 3P4W (3 phases 4 wires star)	“△” 3P4W (3 phases 4 wires angle)
3 phases VPh-N L1-N L2-N L3-N	3 phases VPh-N L1-N L2-N L3-N
3 phases VPh-Ph L1-L2 L2-L3 L3-L1	3 phases VPh-Ph L1-L2 L2-L3 L3-L1
frequency Hz (L1) 3 phases current I1 I2 I3	frequency Hz (L1)
3 phases apparent power AL1 AL2 AL3 ΣA	3 phases current I1 I2 I3
3 phases active power PL1 PL2 PL3 ΣP	active power ΣP
3 phases reactive power QL1 QL2 QL3 ΣQ	reactive power ΣQ
3 phases power factor PFL1 PFL2 PFL3 PF	power factor PF
active energy (KW hr) ΣE	active energy (KW hr) ΣE
reactive energy (KVA hr) ΣE	reactive energy (KVA hr) ΣE

3P3W (3 phases 3 wires)

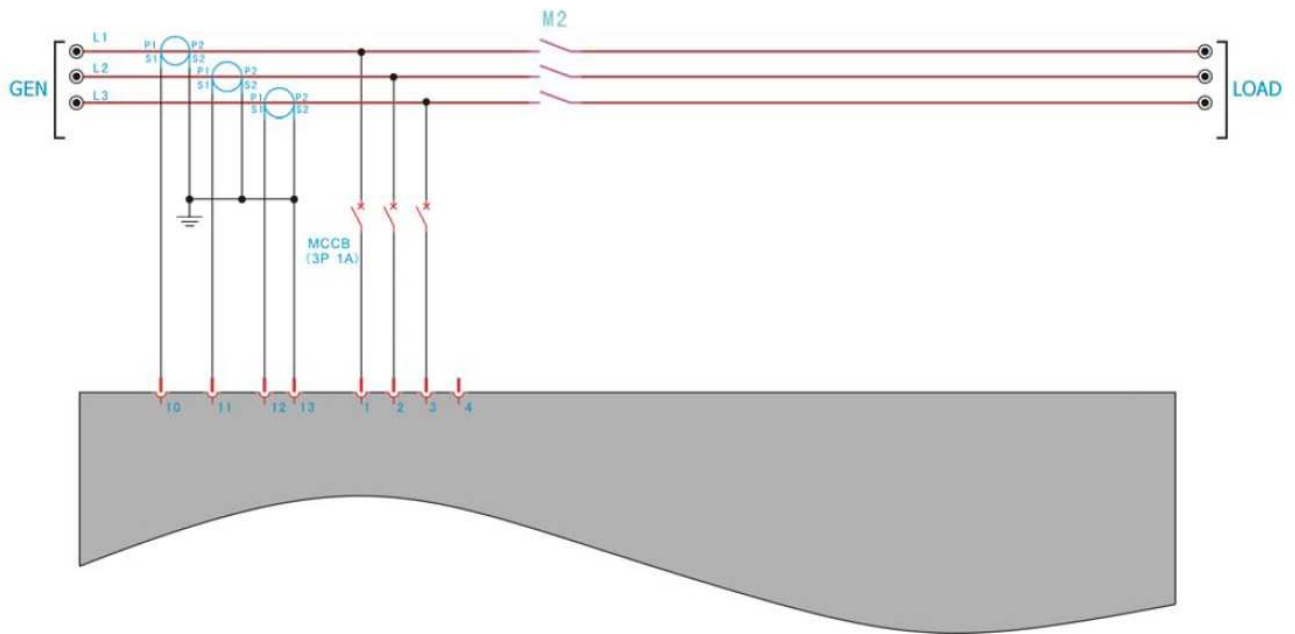

Measure and Display Data
3 phases VPh-Ph L1-L2 L2-L3 L3-L1
frequency Hz (L1)
3 phases current I1 I2 I3
Gen. total apparent power ΣA
total active power ΣP
total reactive power ΣQ
average power factor PF
active energy (KWhr) ΣE
reactive energy (KVAhr) ΣE

1P3W(single phase 3 wires))

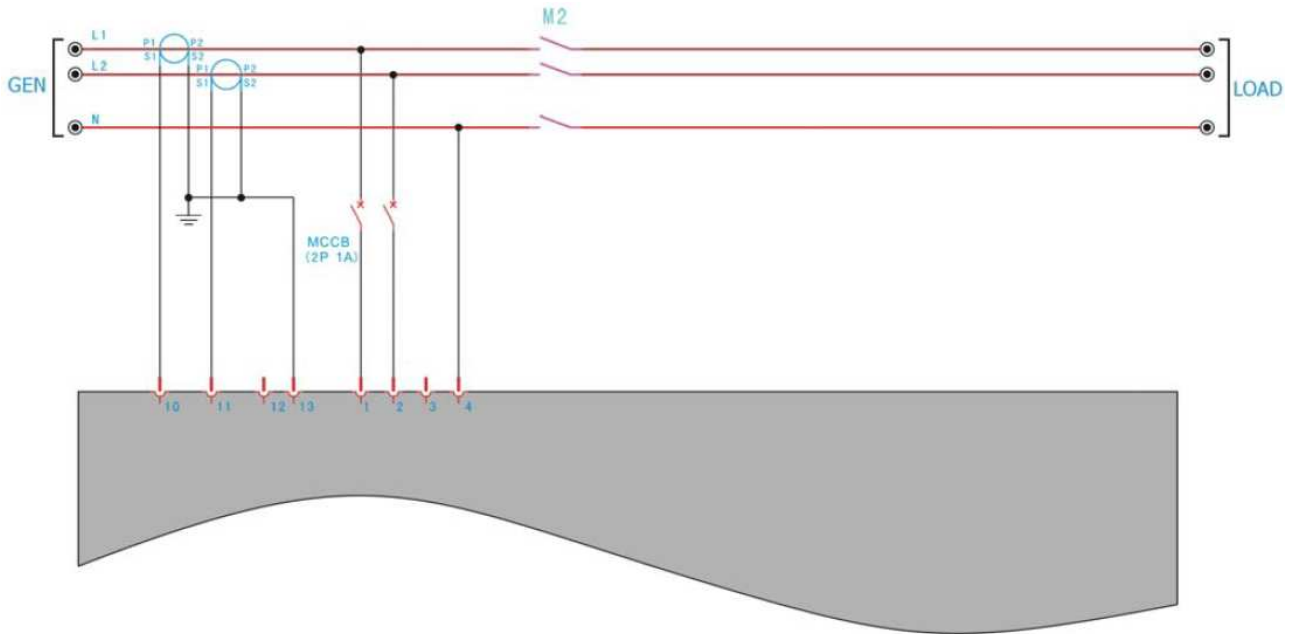

Measure and Display Data

VPh-N L1-N L2-N

VPh-Ph L1-L2

frequency Hz

current I1 I2

apparent power A

active power P

reactive power Q

power factor PF

active energy (KWhr) ΣE

reactive energy (KVAhr) ΣE

1P2W(single phase 2 wires)

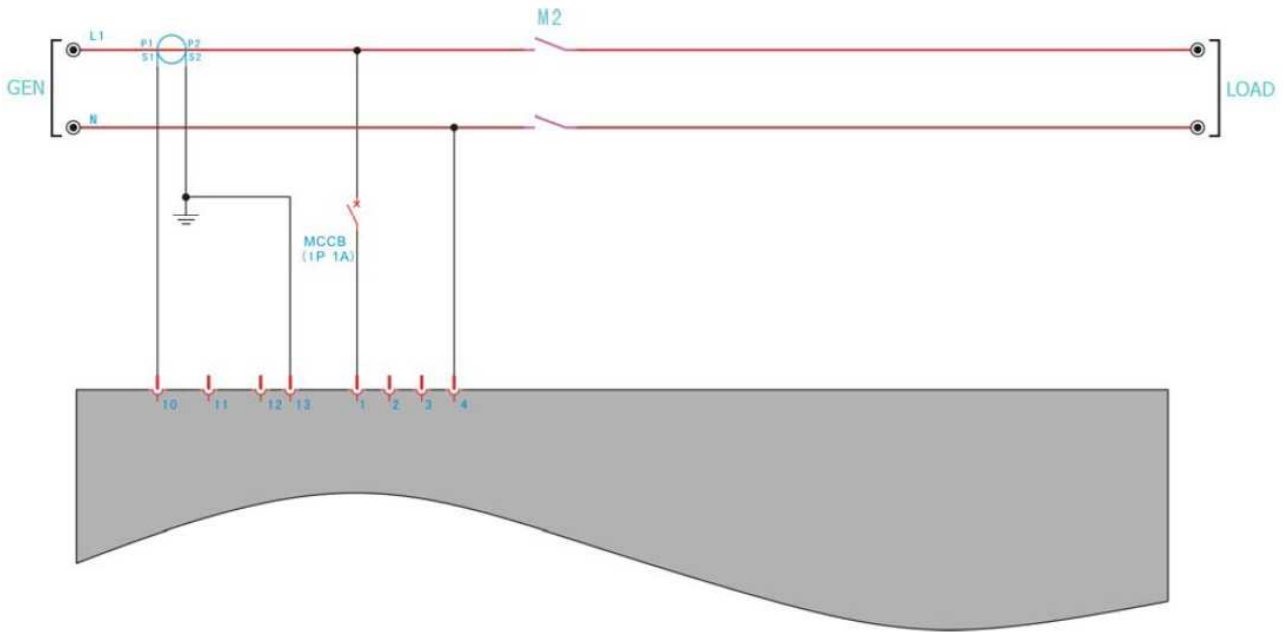

Measure and Display Data

VPh-N L1-N

frequency Hz (L1)

current I1

apparent power A

active power P

reactive power Q

power factor PF

active energy (KWhr) ΣE

reactive energy (KVAhr) ΣE

8.2.6 The connection of configurable digital inputs

There are 7 configurable Inputs, which used for monitoring and control status, all of the Inputs adopt electrical isolation, and controller internal provides 8vdc power supply, no need an additional power.

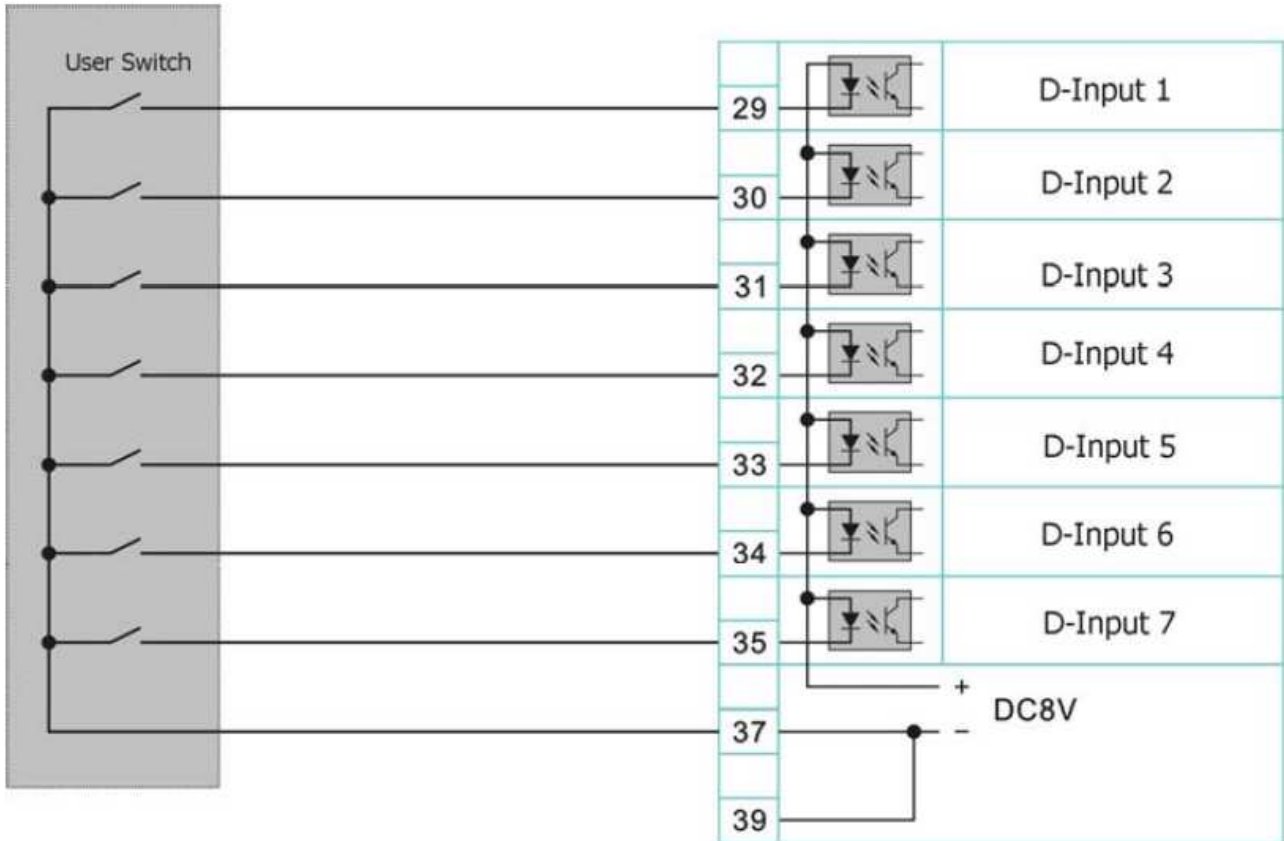

NOTE:



- The terminal #37 is the common port for the configurable inputs and it is short connected to power negative (terminal #39) inside the controller.
- The maximum acceptable resistance for each input is 10KΩ, it means whether the switch of loop circuit is closed or not, the status monitored by controller are all open when the resistance in loop circuit exceeds 10KΩ, status monitored by controller are all close when the resistance in loop circuit falls below 10KΩ. To avoid error monitoring of switch status, do pay attention to the wiring resistance and switch on resistance in loop circuit, and total resistance must be less enough.



CAUTION:

Terminal #37 on controller should not be used as the negative input of battery.

8.2.7 Connection for the configurable output relays

There are 7 relay outputs, except fuel and crank relays which are fixed function, other relays' function all can be configured by user.

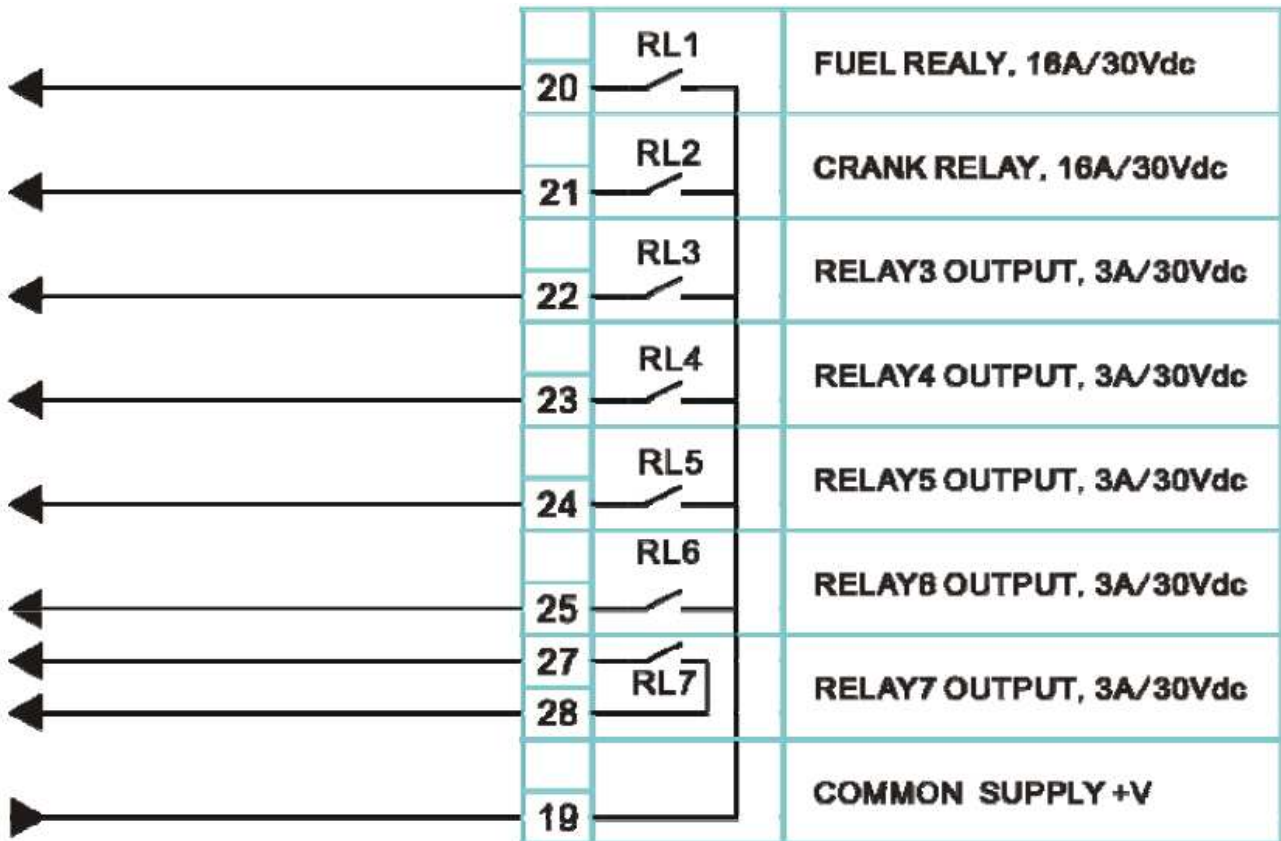

NOTE:



- Terminal #19 is the common port for RL1 to RL6, and it is connected to power positive.
- The output current for each relay can not exceed the rated current of respective relay; the total output current for 6 relays (from RL1 to RL6) can not exceed 16A.
- A switch or fuse for over current protection must be mounted between power and terminal 19#, the recommended capacity is 16A. In practical application, controller output will generate instantaneous peak current, you must consider the peak current when choosing a switch or fuse for over current protection.

9. LCD displays and Menu System

9.1 LCD displays measuring parameters:

Use a back-light graphic LCD to display data and information. Each page can display multi-row information simultaneously, the above 4 rows display measuring data, the last row displays status information, press “” to scroll for viewing next page, it can be configured as auto scroll as well. When alarm occurs, the alarm status is displayed on the LCD immediately.

When controller is configured to use LOP sensor and HET sensor but not connected:





Operation	Description	
Controller does not detect oil pressure and engine coolant temperature, the related data would be displayed as “OPEN” if controller is in standby:	U=0V P=0kW SP=0rpm OP= OPEN Ready	I=0A F=0.0Hz Bat=24.0V TEMP= OPEN







NOTE:





- When HET sensor or LOP sensor is set as “not used”, LCD will not display the related data.

When Genset is running, LCD circularly displays each measuring data:

Operation	Description	
The voltage/current value displayed on this page is the average value of 3 phases. Press “  ” to scroll next page.	U=380V P=0kW SP=1500rpm OP=4.6Bar RUN	I=0A F=50.0Hz Bat=25.4V TEMP=70°C
This page displays electrical parameters for L1, Press “  ” to scroll next page.	V1=220V I1=0A P1=0kW Q1=0kVAr RUN	U12=380V A1=0kVA PF1=1.00
This page displays electrical parameters for L2, Press “  ” to scroll next page.	V2=220V I2=0A P2=0kW Q2=0kVAr RUN	U23=380V A2=0kVA PF2=1.00
This page displays electrical parameters for L3, Press “  ” to scroll next page.	V3=220V I3=0A P3=0kW Q3=0kVAr RUN	U31=380V A3=0kVA PF3=1.00

<p>This page displays Gen power and average power factor, Press “” to scroll next page.</p>	<p>G. P=0KW G. A=0KVA G. Q=0KVA G. PF=1.00 RUN</p>
<p>This page displays running hours, crank attempt, and Auxiliary sensor level, Press “” to scroll next page.</p>	<p>Run Hour=0.0 COUNTERS=0 Fuel= 46 % HEAT= 40 °C RUN</p>
<p>This page displays total active and reactive energy, Press “” to scroll next page.</p>	<p>G. KWHr=0 G. KVAHr=0 RUN</p>
<p>Relay Outputs is the status of configurable relay output. Digital Inputs is the status of configurable inputs. “0” stand for it is active. Press “” to scroll next page.</p>	<p>Relay Outputs : --- 0 ---- Digital Inputs : ---- -- 0 - 运行 M. A=0KVA M. Q=0KVA M. PF=1.00 RUN</p>

9.2 Setting running parameters

Press and hold “” button 2sec to enter into parameter settings menu, then use “+” or “-” to scroll page in the same menu list, press “√” enter into submenu, press “” can return to upper menu, go to menu 1.17 “password” to enter password first, or select the required item, press “√” enter into modify mode, press “+” or “-”, the LCD displays 0 0 0 0 when prompted enter password, then use “+” or “-” to modify the first digital value, press “→” move to modify next digital value, the first digital value will be displayed as “*” after moving to next digital value, press “√” to confirm after the password is set as 2213, then you can modify parameters. Otherwise it will prompt to key in password again. Press and hold “” for more than 2sec or press “” to quit parameter settings mode after finishing configuration.

For example: (setting CT ratio at 500: 5, then CT should be configured as 500)

Operation	Description
Press and hold "▶" 2sec, enter into parameters setting menu, then LCD displays:	[SETTING] 0. QUIT 1. SYSTEM 2. GENERAYOR 3. ENGINE
Press "√" button 2 times, then LCD displays:	[CT ratio] 1000:5
Press "+" or "-" button, prompted enter password (2213), press "√" button to confirm after entering password.	[CT ratio] Password: 0000
Press "+" or "-" to change parameters, change at 500, then LCD displays:	[CT ratio] 500:5
Press "√" to confirm, then press "⬆" to return, then LCD displays:	[SETTING] 0. QUIT 1. SYSTEM 2. GENERAYOR 3. ENGINE
Press "⬆" again or press and hold "▶" 2sec will quit parameter settings menu, then LCD displays:	Ready

For example: (setting controller crank attempt at 2)

Operation	Description
Press and hold "▶" 2sec, enter into parameters settings menu, then LCD displays:	[SETTING] 0. QUIT 1. SYSTEM 2. GENERAYOR 3. ENGINE
Press "+" 2 times and then press "√", then LCD displays:	[ENGINE] 0. QUIT 1. Rated speed 2. MPU input 3. Fly wheel teeth
Press "+" 9 times and then press "√", then LCD displays:	[Crank attempt] 3
Press "+" or "-" button, prompted enter password (2213), press "√" button to confirm after entering password.	[Crank attempt] Password: 0000
Press "+" or "-" to change parameters, change at 2.	[Crank attempt] 2
Press "√" button to confirm, and then press "⬆" or press and hold "▶" 2sec will quit parameter settings menu.	READY

For example: (resume parameters of controller to factory defaults)

Operation	Description
Press and hold "▶" 2sec, enter into parameters settings menu, then LCD displays:	[SETTING] 0. QUIT 1. SYSTEM 2. GENERAYOR 3. ENGINE
Press "√" button and then press "-" 8 times, then LCD displays:	[SETTING] 0. QUIT 1. SYSTEM 12. Telephone 1 NO. 13. Telephone 2 NO. 14. Telephone 3 NO. 15. Default settings
Press "√" button, prompted enter password (2213), press "√" button to confirm after entering password.	[Default settings] Password: 0000
Press "√" button to confirm, and then press "↶" or press and hold "▶" 2sec will quit parameter settings menu.	[SYSTEM] DONE

For example: (configure controller at online program mode)

Operation	Description
Press and hold "▶" 2sec, enter into parameters settings menu, then LCD displays:	[SETTING] 0. QUIT 1. SYSTEM 2. GENERAYOR 3. ENGINE
Press "√" and then press "-" twice, then LCD displays:	[SYSTEM] 18. Engine ECU type 19. Display contrast 20. Auto scroll time 21. Firmware update
Press "√" button, prompted enter password (3132), press "√" button to confirm after entering password.	21. Firmware update Password: 0000
Press "√" again to enter into online program mode, then LCD displays: Use the comm. cable and the software to program, please make sure the power supply is normal during programming, the controller will reset automatically after programming. If you have entered into this mode already, but you do not program, you need to turn the controller off to exit this mode.	Firmware Update. Download from PC. Don't turnoff power, before finished!

10. Technical Specification

10.1 AC voltage:

Measurement	True RMS
Phase to Neutral	15 to 330VAC
Phase to Phase	25 to 572VAC
Max power wastage per line	<0.1W
Accuracy	1%
Display	0 to 600KV

10.2 AC voltage frequency:

Input frequency	3 to 70Hz (voltage \geq 15VAC)
Accuracy	0.1%
Display	0 to 100Hz

10.3 Current (isolated):

Measurement	True RMS
Measuring current	5A
Accuracy	1%
Display	0 to 30000A
Max power wastage per line	<0.01W

10.4 Power supply:

Range	12V/24V (8-35V continuous)
Max. operating current	@12V 310mA, @24V 155mA
Max. standby current	@12V 100mA, @24V 50mA
Cranking dropouts	0V for 80ms, assuming battery supply was at least 10V before dropout and recovers to 5V
Accuracy	1%
Display	0 to 40V

10.5 Configurable digital inputs:

Number	7
Max. contact resistance	10K Ω
Type	Isolated
Max. contact current per line	1mA

10.6 Configurable relay outputs:

Fuel relay	16A/30Vdc
Start relay	16A/30Vdc
Aux relay	3A/30Vdc

10.7 Charge failure input:

Range	0 to 35Vdc
Accuracy	1%
Max output current	@12V 120mA, @24V 240mA

10.8 Analog Inputs:

Number	4
Sensor type	resistance
Resolution	10 bits
Range	0 to 1K Ω
Accuracy	2% When full scale, except for sensor error

10.9 Magnetic pickup:

Voltage range	1 to 70V
Max. frequency	10000Hz
Fly wheel teeth	5 to 300

10.10 Ambient parameters:

Operating ambient temperature Standards	-20 to 70°C IEC60068-2-1 and IEC60068-2-2
Storage ambient temperature Standards	-30 to 80°C IEC60068-2-1 and IEC60068-2-2
Humidity Standards	60°C, 95%RH, 48 hours IEC60068-2-30
Electro Magnetic compatibility (EMC) Standards	EN 61000-6-4 and EN 61000-6-2
Vibration Standards	EN 60068-2-6
Shock Standards	EN 60068-2-27
Electrical safety Standards	EN 60950-1
Degrees of protection Standards	IP65 (front) IP20 (back) BS EN 60529

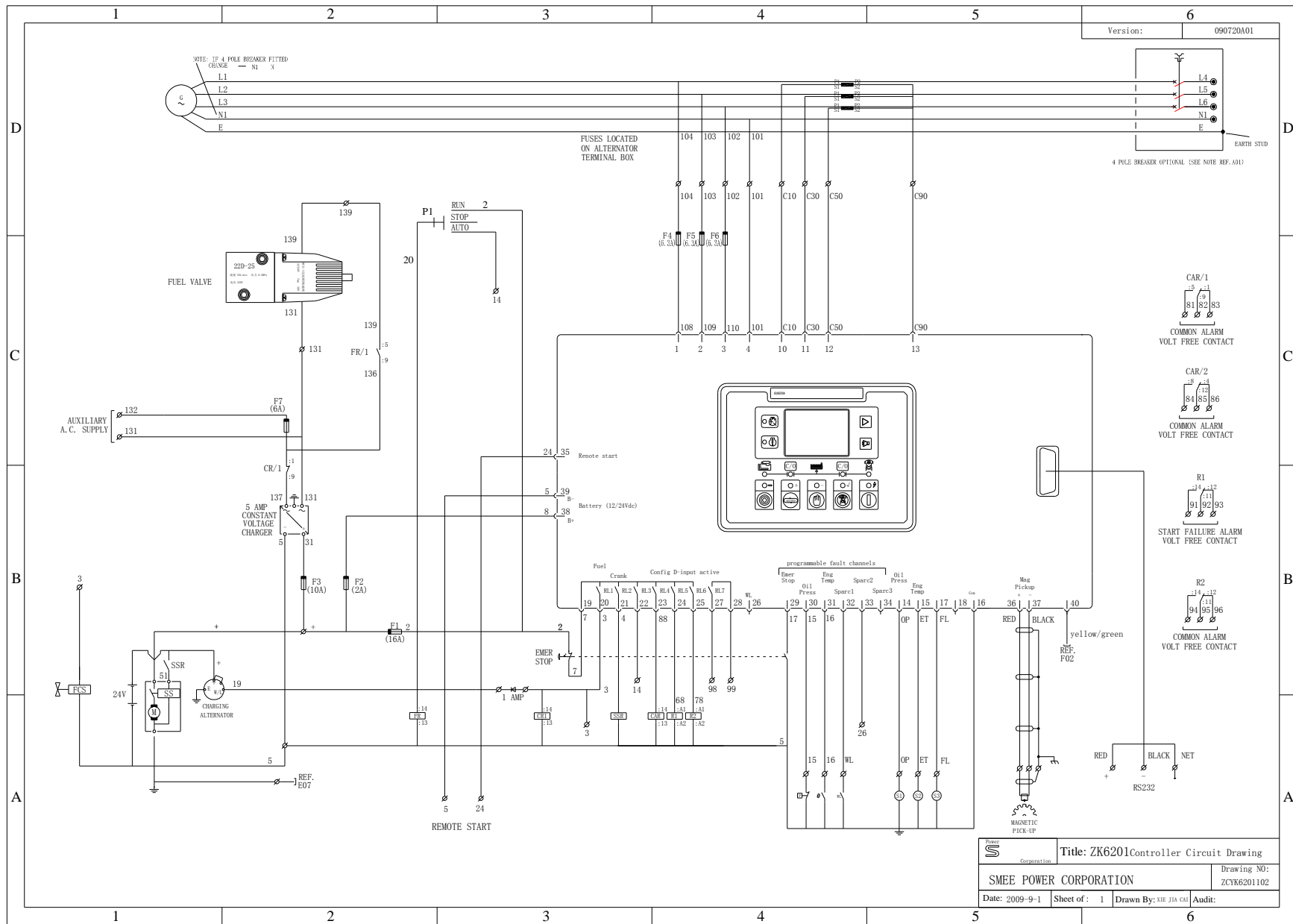

Title: ZK6201 Controller Circuit Drawing	
SMEE Corporation	Drawing NO: ZCYK6201102
Date: 2009-9-1	Sheet of: 1
Drawn By: XIE JIA CAI	Audit:

ZINGS POWER SCIEN-TECH (HANGZHOU) CO., LTD.

Add:NO. 129, Yifeng Road, Economic and Technological
Development Zone, Hangzhou (310018)

Tel/Fax:0086-571-85803976

E-mail:zings@china-zings.com

Http://www.china-zings.com