

STMicroelectronics

EVALSPEAR320CPU SPEAR320 CPU evaluation board

UM1015
User manual

Doc ID 18124 Rev 1

October 2010

www.st.com



BLANK

Introduction

This document applies to revision 2.0 SPEAr320 CPU evaluation boards.

This board can be used to evaluate SPEAr320 microprocessors; the evaluation board kit comprises one board, one serial cable interface, and one power supply.

CPU board features

- SPEAr320 embedded MPU
- Up to 2 Gbit DDR2 333 MHz (standard 128 Mbytes)
- Up to 16 Mbyte Serial Flash memory (standard 8 Mbytes)
- Two USB 2.0 full host port channels
- One USB 2.0 host device port
- One serial port (up to 115 baud)
- JTAG Debug ports

Figure 1. SPEAr320 CPU evaluation board

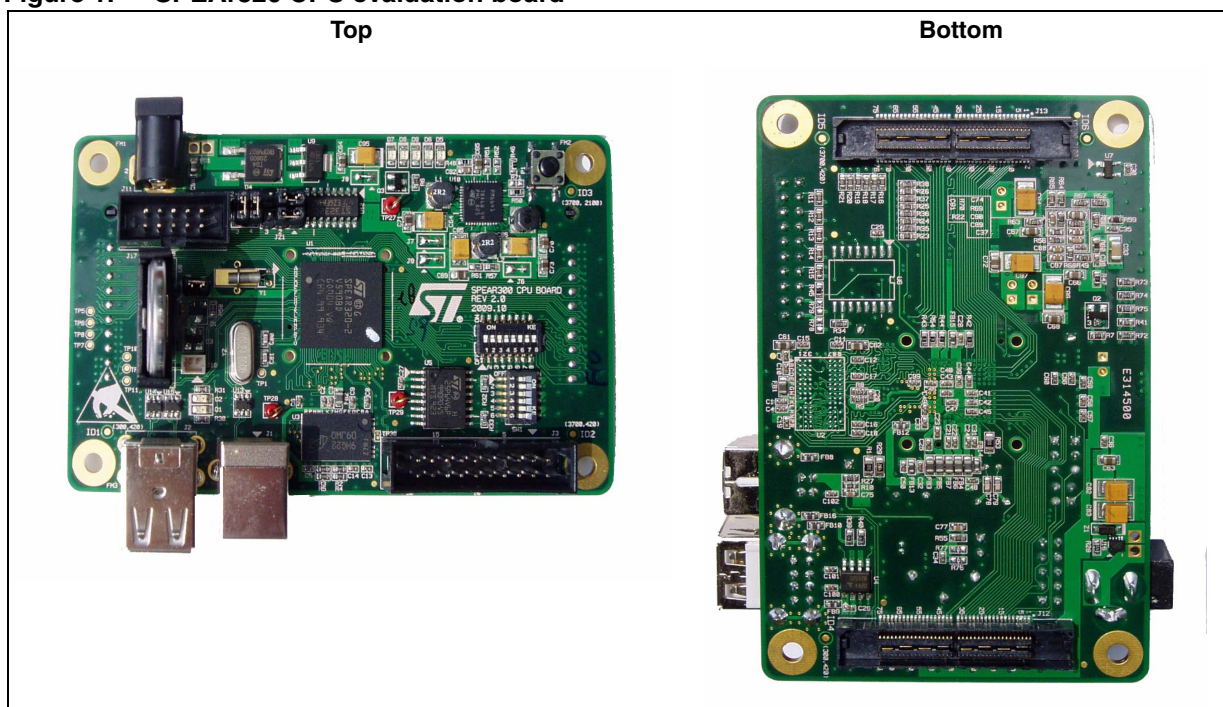

Contents

- 1 Getting started 7**
 - 1.1 Connections 7
 - 1.2 Booting procedure 7
- 2 Block diagram 8**
- 3 Expansion connectors 11**
- 4 Switch and jumper settings 15**
 - 4.1 Switch 1 settings 15
 - 4.2 Switch 2 settings 16
 - 4.3 Jumpers and connectors 17
- 5 Board components 18**
- 6 Schematics 22**
- 7 Board layout 31**
- 8 Revision history 32**
 - 8.1 Hardware revision history 32
 - 8.2 Document revision history 32
- A License agreements 33**

List of tables

Table 1.	Switch SW1 bits [2:1]	9
Table 2.	CPU board extension connector J12	11
Table 3.	CPU board extension connector J13	13
Table 4.	Switch 1 (SoC functional configuration)	15
Table 5.	Switch 1 (debug configuration)	15
Table 6.	Switch 1 (functional configuration)	15
Table 7.	Switch 2 settings	16
Table 8.	CPU board components	18
Table 9.	Document revision history	32

List of figures

Figure 1.	SPEAr320 CPU evaluation board	3
Figure 2.	EVALSPEAr320CPU board block diagram	8
Figure 3.	Serial cable setting	9
Figure 4.	86-pin connectors (J12 and J13)	11
Figure 5.	Schematic interconnections	22
Figure 6.	DDR interface schematic	23
Figure 7.	USB interface schematic	24
Figure 8.	USB power and optional part schematic	25
Figure 9.	Miscellaneous interfaces schematic	26
Figure 10.	Power supply schematic	27
Figure 11.	Customization interface schematic	28
Figure 12.	Daughterboard interface schematic	29
Figure 13.	Schematic revision history	30
Figure 14.	SPEAr320 CPU evaluation board layout (top view)	31
Figure 15.	SPEAr320 CPU evaluation board layout (bottom view)	31

1 Getting started

Warning: This board contains static sensitive devices.

The EVALSPEAR320CPU board is shipped in protective anti-static packaging. Do not submit the board to high electrostatic potentials, and follow good practices for working with static sensitive devices.

- **Wear an anti-static wristband.** Wearing a simple anti-static wristband can help prevent ESD from damaging the board.
- **Zero potential.** Always touch a grounded conducting material before handling the board, and periodically while handling it.
- **Use an anti-static mat.** When configuring the board, place it on an anti-static mat to reduce the possibility of ESD damage.
- **Handle only the edges.** Handle the board by its edges only, and avoid touching board components.

1.1 Connections

Refer to [Figure 14 on page 31](#).

1. Connect a serial cable from connector J17 (serial link) to a host PC.
2. On the host PC running Windows or Linux, start the Terminal program.
3. Connect the +5 V voltage adapter (supplied in the EVALSPEAR320CPU package) to the J11 power voltage connector on the CPU board.
4. Apply power to the board.
5. The Terminal program displays a sequence of boot messages followed by the Linux console prompt.

For more information, refer to user manual *UM0844 Getting started with Linux for SPEAr*, available at www.st.com/spear.

1.2 Booting procedure

The SPEAr320 CPU evaluation board can boot a Linux kernel that has been pre-installed in the serial NOR Flash.

At power on, the serial port outputs a brief header message with some uBoot information (uBoot version, SDK version, and some internal hardware information). At this point you can choose to:

- **Stop the system directly in uBoot:** Press the spacebar on the host computer keyboard before the boot delay time expires (default is 3 seconds).
- **Boot Linux:** The system logs you in automatically as super user, and displays the Linux shell prompt on the screen.

2 Block diagram

Figure 2. EVALSPEAr320CPU board block diagram

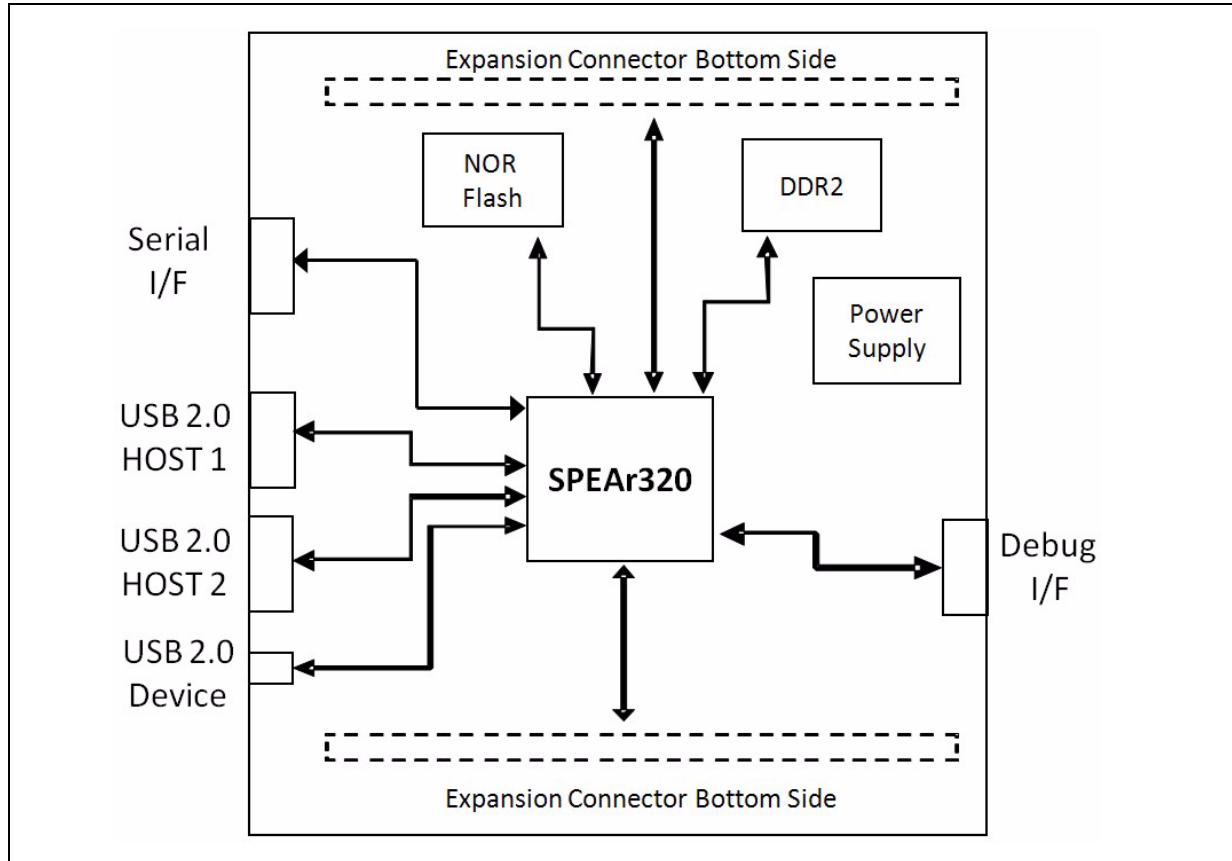

2.0.1 Dynamic memory subsystem

The Dynamic memory subsystem comprises three major parts:

Memory chip

The SPEAr320 MPU supports up to 256 Mbytes of memory. Place and route is provided for 2 chips but only one has been populated. The memory used is a Micron DDR2 device, its part number is MT47H64M16HR-3 and its size is 128 Mbits x 8 (16 Mbits x 8 x 8 banks).

Local power supply

The local power supply is based on a monolithic voltage regulator for the chip set and DDR2/3 (PM6641). It is generated locally in order to minimize the layout impact and also to avoid any noise injection between different subsystems.

Signal termination

A parallel termination is added on the clock lines to compensate, if needed, for the layout dissymmetry. Two 100k ohm resistors are used for each line in order to obtain an impedance of 50 ohms. All the other terminations are directly inside the pads (both on the SPEAr320 MPU and the memory sides).

2.0.2 Static memory subsystem (Serial Flash memory)

The SPEAr320 MPU supports up to 16 Mbytes of Serial Flash memory. Place and route for 2 blocks of 8 Mbytes are provided on the board, but only one is populated. It is based on an M25P64-VMF6P (Numonix) Serial Flash memory device.

Resistor R8 protects the Flash memory from any unwanted write access.

2.0.3 USB 2.0 subsystem

Host ports

The board has two host ports that are fully compliant with the USB 2.0 specification (two controllers with one port each). This means that the two hosts can work in concurrent mode with the maximum possible bandwidth. Each host has also full control of the VBUS supplied by the ST2052 power switch that also provides over current protection in case of a short circuit in the USB cable.

Device port

The board has one USB 2.0 device port.

2.0.4 Debug interface

The JTAG interface can be used for *static* debugging, which means that it is possible to set a breakpoint, and when the system stops, verify the contents of the memory or registers, or both, and modify them if needed.

To select the debug feature, set Switch SW1 bits [2:1].

Table 1. Switch SW1 bits [2:1]

Bit 2	Bit 1	Description
0	0	No debug features available
0	1	The ARM JTAG is connected to J4

For more information on the ETM interface, refer to the trace box manufacturer's documentation (www.lauterbach.com, www.agilent.com, www.yokogawa.com).

2.0.5 Serial interface

One serial interface port is available. Typically used as an OS monitor, this port is available on the J17 connector. It is possible to simulate a cross cable by changing the position of the J22 jumpers.

Figure 3. Serial cable setting

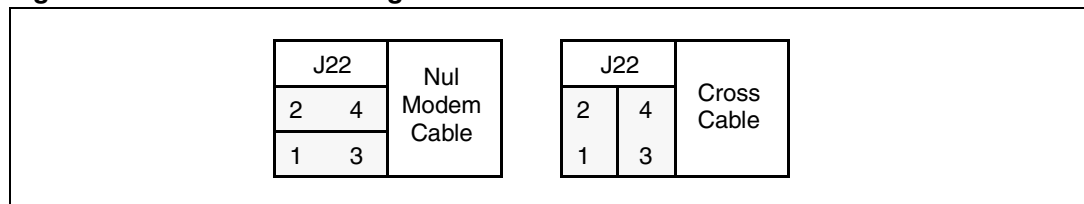

2.0.6 Real time clock (battery powered)

The real time clock (RTC) is powered by an external battery (3V) in order to prevent data loss even if the main power supply is switched off.

2.0.7 General power supply

From a 5 V external AC/DC regulator power source, this block generates all the required voltages as follows:

- 1.2V (Switching regulator PM6641) to supply the internal logic of the SPEAr320 MPU
- 1.8V (Switching regulator PM6641) for the DDR2 memory
- 2.5V (LDO regulator) for the analog portion of SPEAr320
- 3.3V (Switching regulator PM6641) to supply the other interfaces

A power monitor is also present to provide the general reset of the board.

2.0.8 Reset button

A manual reset button (P1) on the top of the board (see [Figure 14 on page 31](#)) resets the microprocessor on the core board.

3 Expansion connectors

The CPU board has two 86-pin connectors (J12 and J13) that are used to extend the board. On the board the connectors are horizontally center-aligned, and the distance between the mechanical holes is 3400.00 th.

Table 2 lists connector J12 pins.

Table 3 on page 13 lists connector J13 pins.

Note: Connector through hole pins (10 pins) are connected to GND

Figure 4. 86-pin connectors (J12 and J13)

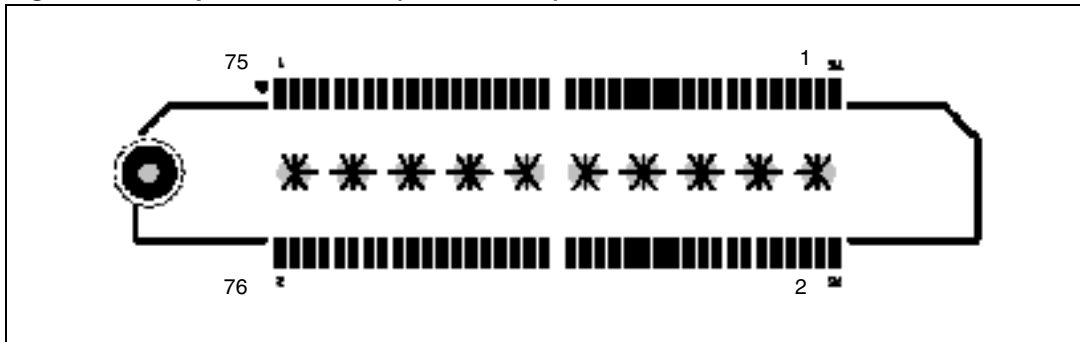

Table 2. CPU board extension connector J12

Pin	Description	Pin	Description
1	+1.8V	2	+5V
3	+1.8V	4	+5V
5	+1.8V	6	+5V
7	+1.8V	8	+5V
9	PL_GPIO2 (RS232-TX LVTTTL) ⁽¹⁾	10	PL_GPIO44
11	PL_GPIO3 (RS232-RX LVTTTL) ⁽²⁾	12	PL_GPIO39
13	RS232-TX ⁽³⁾	14	PL_GPIO40
15	RS232-RX ⁽⁴⁾	16	PL_GPIO38
17	PL_GPIO42	18	PL_GPIO29
19	PL_GPIO43	20	PL_GPIO37
21	PL_GPIO34	22	PL_GPIO30
23	PL_GPIO33	24	PL_GPIO28
25	PL_GPIO16	26	PL_GPIO26
27	PL_GPIO24	28	PL_GPIO27
29	PL_GPIO20	30	PL_GPIO9
31	PL_GPIO23	32	PL_GPIO13
33	PL_GPIO18	34	PL_GPIO8

Table 2. CPU board extension connector J12 (continued)

Pin	Description	Pin	Description
35	PL_GPIO11	36	PL_GPIO6
37	PL_GPIO19	38	PL_GPIO4
39	PL_GPIO15	40	PL_GPIO5
41	PL_GPIO14	42	NC
43	PL_GPIO36	44	NC
45	PL_GPIO41	46	NC
47	PL_GPIO35	48	NC
49	PL_GPIO31	50	+2.5V
51	PL_GPIO32	52	+2.5V
53	PL_GPIO25	54	+2.5V
55	PL_GPIO22	56	+2.5V
57	PL_GPIO21	58	INRESET
59	PL_GPIO17	60	nRESET
61	PL_GPIO12	62	+1.2V
63	PL_GPIO10	64	+1.2V
65	PL_GPIO7	66	+1.2V
67	PL_GPIO1	68	+1.2V
69	PL_GPIO0	70	+3.3V
71	NC	72	+3.3V
73	NC	74	+3.3V
75	NC	76	+3.3V
77	GND ⁽⁵⁾	78	GND ⁽⁵⁾
79		80	
81		82	
83		84	
85		86	

1. If J20 Jumper is set to pin2-3, otherwise NC.
2. If J21 Jumper is set to pin2-3, otherwise NC.
3. If J22 Jumper is set to pin2-4 and pin1-3, otherwise RS232-RX.
4. If J22 Jumper is set to pin2-4 and pin1-3, otherwise RS232-TX.
5. Physically connected to the internal metal plane of the connector. Pins 77 through 81 and 82 through 86 are shorted together.

Table 3. CPU board extension connector J13

Pin	Description	Pin	Description
1	PL_GPIO47	2	+3.3V
3	PL_GPIO49	4	PL_GPIO63
5	PL_GPIO56	6	PL_GPIO46
7	PL_GPIO58	8	PL_GPIO57
9	PL_GPIO64	10	PL_GPIO61
11	PL_GPIO45	12	PL_GPIO66
13	PL_GPIO48	14	PL_GPIO69
15	PL_GPIO50	16	PL_GPIO72
17	PL_GPIO55	18	PL_GPIO73
19	PL_GPIO59	20	PL_GPIO70
21	PL_GPIO60	22	PL_GPIO67
23	PL_GPIO65	24	PL_GPIO71
25	PL_GPIO62	26	PL_GPIO75
27	PL_GPIO68	28	PL_GPIO82
29	PL_GPIO52	30	PL_GPIO76
31	PL_GPIO53	32	PL_GPIO85
33	PL_GPIO51	34	PL_GPIO87
35	PL_GPIO54	36	PL_GPIO95
37	PL_GPIO74	38	PL_GPIO79
39	PL_GPIO77	40	PL_GPIO94
41	PL_GPIO78	42	ADC VREFN
43	PL_GPIO81	44	AIN0
45	PL_GPIO80	46	GND
47	PL_GPIO84	48	AIN1
49	PL_GPIO83	50	GND
51	PL_GPIO86	52	AIN2
53	PL_GPIO91	54	GND
55	PL_GPIO90	56	AIN3
57	PL_GPIO96	58	GND
59	PL_GPIO88	60	AIN4
61	PL_GPIO89	62	GND
63	PL_GPIO92	64	AIN5
65	PL_GPIO93	66	GND
67	PL_GPIO97	68	AIN6
69	PL_CLK4	70	GND

Table 3. CPU board extension connector J13 (continued)

Pin	Description	Pin	Description
71	PL_CLK3	72	AIN7
73	PL_CLK2	74	GND
75	PL_CLK1	76	ADC VREFP
77	GND ⁽¹⁾	78	GND ⁽¹⁾
79			
81			
83			
85			
86			

1. Physically connected to the internal metal plane of the connector. Pins 77 through 81 and 82 through 86 are shorted together.

4 Switch and jumper settings

4.1 Switch 1 settings

Table 4. Switch 1 (SoC functional configuration)

Bit	Description
1	Test – see Debug configuration below
2	Reserved
3	Reserved
4	Reserved
5	Reserved
6	BootSel – see Debug configuration below

Table 5. Switch 1 (debug configuration)

Test bit		Debug configuration
2	1	
0	0	Normal Mode (No debug enabled)
0	1	ARM1 JTAG connected to J4
1	0	Reserved

Table 6. Switch 1 (functional configuration)

Test bit				Functional configuration
6	5	4	3	
1	0	1	1	Configuration 3

Note: When Switch SW1-x is in the ON position, the bit value is 0. When Switch 1 is in the OFF position, the bit value is 1.

Bits 3, 4, 5 and 6 enable you to set the Functional configuration. The default configuration is **Configuration 3**. For other configurations, refer to the SPEAr320 user manual available at www.st.com/spear.

4.2 Switch 2 settings

Table 7. Switch 2 settings

Boot from	SW2-1	SW2-2	SW2-3	SW2-4	SW2-5	SW2-6	SW2-7	SW2-8
USB_BOOT	Off	On	Off	On	Off	On	Off	On
ETH (parameter from I2C ROM)	On	Off	Off	On	Off	On	Off	On
ETH (parameter from SPI ROM)	Off	On	On	Off	Off	On	Off	On
Serial NOR (default setting)	On	Off	On	Off	Off	On	Off	On
Parallel NOR 8 (EMI with ACK)	Off	On	Off	On	On	Off	Off	On
Parallel NOR 16 (EMI with ACK)	On	Off	Off	On	On	Off	Off	On
Parallel NAND 8	Off	On	On	Off	On	Off	Off	On
Parallel NAND 16	On	Off	On	Off	On	Off	Off	On
Reserved for SPI	Off	On	Off	On	Off	On	On	Off
Reserved for I ² C	On	Off	Off	On	Off	On	On	Off
UART_BOOT	Off	On	On	Off	Off	On	On	Off
BootROM bypass	On	Off	On	Off	Off	On	On	Off
Parallel NOR 8 (EMI without ACK)	Off	On	Off	On	On	Off	On	Off
Parallel NOR 16 (EMI without ACK)	On	Off	Off	On	On	Off	On	Off
Reserved	Off	On	On	Off	On	Off	On	Off
Reserved	On	Off	On	Off	On	Off	On	Off

Note: If SW2-1 and SW2-2 are both off, B0 (pin PL_GPIO51) is in HiZ state, and can be controlled from the application board.

If SW2-3 and SW2-4 are both off, B1 (pin PL_GPIO52) is in HiZ state, and can be controlled from the application board.

If SW2-5 and SW2-6 are both off, B2 (pin PL_GPIO53) is in HiZ state, and can be controlled from the application board.

If SW2-7 and SW2-8 are both off, B3 (pin PL_GPIO54) is in HiZ state, and can be controlled from the application board.

SW2-1 and SW2-2 on: invalid condition

SW2-3 and SW2-4 on: invalid condition

SW2-5 and SW2-6 on: invalid condition

SW2-7 and SW2-8 on: invalid condition

4.3 Jumpers and connectors

The jumpers and connectors numbered below refer to the CPU board schematics (available on www.st.com/spear).

Sheet 4

- Connector J3 is a standard 20-pin 2.54 mm connector used for JTAG connections.
- Jumper J5 enables the power supply to the Real Time Clock block.
If jumper J5 is closed, the RTC is powered (standard).
- Connector J10 is a 2 via 1.25 mm pitch connector for battery back-up with cable.

Sheet 5

- Connector J11 is a standard power connector for the ADC power supply with a 2.1-mm central pitch.

Sheet 6

- Jumpers J6, J7, J8 and J9 are serial jumpers for the SPEAr power rail.
All jumpers **MUST** be closed. This configuration is used for power measurements.

Sheet 7

- Jumper J22 is a 4-pin symmetric IDC (or strip) connector that switches RX and TX signals for different types of RS-232 cables^(a):
 - Two pins are connected to the ST3232 Receive/Transmit side.
 - Two pins are connected to the RS-232 Receive/Transmit connector side.
- Connector J17 is a connector for standard IDC-to-DSUB converters.
- Jumper J20 switches between RS-232 transmit signals or GPIO2:
 - If jumper is on pins 1 and 2, pin PL_GPIO2 is connected to U12 (ST3232) and the COM0 is available on J17.
 - If jumper is on pins 2 and 3, pin PL_GPIO2 is connected to the expansion connector J12 pin 9. In this case the COM0 is available on CN13.
- Jumper J21 switches between RS-232 receive signals or GPIO3:
 - If jumper is on pins 1 and 2, pin PL_GPIO3 is connected to U12 (ST3232) and the COM0 is available on J17.
 - If jumper is on pins 2 and 3, pin PL_GPIO3 is connected to the expansion connector J12 pin 11. In this case the COM0 is available on CN13.

a. With 2 jumpers (inserted) it is possible to switch between two jumper inserted vertically and two jumpers inserted horizontally. This enables the serial cable (null modem cable) to be adapted to the CPU board.

5 Board components

Table 8. CPU board components

Component	Designator	Footprint	Description
Capacitor	C1 C2 C3 C4 C5 C6 C7 C8 C9 C10 C11 C12 C13 C14 C15 C16 C17 C18 C19 C20 C21 C22 C23 C24 C25 C26 C27 C28 C29 C30 C31 C32 C33 C34 C35 C36 C37 C38 C39 C40 C41 C42 C43 C44 C45 C46 C47 C48 C49 C50 C56 C57 C58 C59 C60 C99 C100 C101 C102	0402	Ceramic capacitor 0.1uF 10% 10V X5R 0402
Resistor	R42 R43 R44 R45 R46 R47 R48 R50	0603	Resistor 0603 0 ohm
Resistor	R30 R31 R32 R33 R34 R35 R36 R37 R38 R72 R73 R74	0603	Resistor 0603 1k ohm 1% 0.1W
Inductor	L3	LPS3.9X3.9	Power Inductor 1uH 1.7A 3.9x3.9mm SMD
Capacitor	C89	0603	Ceramic capacitor 2.2nF 10% 50V X7R 0603
Inductor	L1 L2	LPS3.9X3.9	Power Inductor 2.2uH 1.2A 3.9x3.9mm SMD
Resistor	R59 R60	0603	Resistor 0603 4.3 ohm 1% 0.1W
Resistor	R27 R28	0603	Resistor 0603 4.7k ohm 1% 0.1W

Table 8. CPU board components (continued)

Component	Designator	Footprint	Description
Resistor	R10 R11 R12 R13 R14 R15 R16 R17 R18 R19 R20 R21 R22 R23 R24 R25 R26	0603	Resistor 0603 10k ohm 1% 0.1W
Capacitor	C75 C76 C77	0603	Ceramic capacitor 10 nF 10% 50V X7R 0603
Capacitor	C61 C62 C63 C64 C65 C66 C67 C68 C69 C70 C71 C72 C73 C74 C98	0805	Ceramic capacitor 10uF 10% 10V X5R 0805
Resistor	R68	0603	Resistor 0603 15k ohm 1% 0.1W
Capacitor	C78 C79	0603	Ceramic capacitor 15pF 5% 50V COG 0603
Capacitor	C87 C88 C91	0603	Ceramic capacitor 22nF 10% 50V X7R 0603
Capacitor	C93	1206	Ceramic capacitor 22 uF Y5V -20+80% 6.3V 1206
Crystal oscillator	Y2	RAD-HC49	Crystal Oscillator 24MHz 30ppm through-hole
Resistor	R70	0603	Resistor 0603 27k ohm 1% 0.1W
Crystal oscillator	Y1	XT38T	Crystal Oscillator 32.768KHz 20ppm d2x6mm
Capacitor	C92	0603	Ceramic capacitor 33 nF 10% 50V X7R 0603
Capacitor	C80 C81	0603	Ceramic capacitor 33pF 5% 50V COG 0603
Resistor	R29	0805	Resistor 0805 43.2 ohm 0.1% 0.1W
Resistor	R69	0603	Resistor 0603 47k ohm 1% 0.1W
Capacitor	C82 C83 C84 C85 C86 C94 C95 C96 C97	3528+	Tantalium Capacitor 47uF 10% 10V 3528-21
Resistor	R49	0603	Resistor 0603 56k ohm 1% 0.1W
Resistor	R62 R63 R64 R65 R66 R67	0603	Resistor 0603 68k ohm 1% 0.1W
Resistor	R61	0603	Resistor 0603 75k ohm 1% 0.1W
Resistor	R2 R3 R4 R5 R6 R7	0603	Resistor 0603 100 ohm 1% 0.1W

Table 8. CPU board components (continued)

Component	Designator	Footprint	Description
Resistor	R1 R53	0805	Resistor 0805 121k ohm 0.1% 0.1W
Resistor	R55 R56 R57	0603	Resistor 0603 150 Kohm 1% 0.1W
Resistor	R39 R40	0603	Resistor 0603 150 ohm 1% 0.1W
Resistor	R75	0603	Resistor 0603 330 ohm 1% 0.1W
Resistor	R58	0603	Resistor 0603 390k ohm 1% 0.1W
Resistor	R8 R9	0603	Resistor 0603 470 ohm 1% 0.1W
Capacitor	C90	0603	Ceramic capacitor 470 pF 10% 50V X7R 0603
Resistor	R41	0603	Resistor 0603 680 ohm 1% 0.1W
Battery	U8	BR2032	BATT BR2032: Coin type Lithium batterie 3V straight d20mm
Ferrite bead	FB3 FB4 FB5 FB6 FB7	0805	Ferrite Murata BLM21BD601SN1D 600 ohm/100MHz 200mA 0.35hm 0805
Diode	D3	SOT23	Hi speed switching dual diode 200mA 70V D BAV70
DC power socket	J11	DPS2.5MM	DC Power socket 2.5mm
DIP switch	SW1	SWM-6X-SMD	Surface mount 6-way micro dip switch pitch1.27mm
DIP switch	SW2	SWM-8X-SMD	Surface mount 8-way micro dip switch pitch1.27mm
Ferrite bead	FB8 FB9 FB12 FB13 FB14 FB15 FB10 FB16	0603	Ferrite 2506033007Y0 SMD 400mA
LED	D5 D6 D7 D8 D9	0805P	LED SMD 2,0 x 1,25mm Superbright Green
Connector	J17	IDC5X2MD	IDC 5X2 MD POL; IDC header 10pin p2.54mm straight male polarized
Connector	J3	IDC10X2MD	IDC header 20pin p2.54mm straight male polarized
LED	D1 D2	0805P	Led SMD 2,0 x 1,25mm Superbright red
Memory	U5	SO16	M25P64; Numonix 64Mbit SPI Serial Flash Memory 3.3V 16pin SO
Diode	Z1	SOD123-C425	MMSZ5232BT1; Zener Diode 5.6V 0.5W
Connector	J10	MLX-1.25MM-M	MOLEX 1.25MM 2W M; Molex 1.25mm 2way male straight
SDRAM	U2 U3	FBGA84	MT47H64M16HR3; MICRON DDR2 128MB 1.8V FBGA84
Transistor	Q1	SOT23	NPN BC848; NPN transistor 30Vbc 5Vbe 100mA
Transistor	Q2 Q3	SOT23	NPN PDTD123Y; Digital transistor NPN Rb 2.2K Re 10K 500mA 250mW SOT23
Pad	PD1	PDX280H60SQ	PADX2-80H60; Two square pad 80x80mils 60mils Hole 100mils pitch
Resistor	R54	0603	R 0603 0 OHM; Resistor 0603 0 ohm

Table 8. CPU board components (continued)

Component	Designator	Footprint	Description
Connector	J12 J13	MIS-038	SAMTEC-MIS-038; SAMTEC MIS series 76pin 0.64mm pitch
Rectifier	D4	DPAK	SCR TS420-B_1; Schottky barrier rectifier 1A 60V SMD
Embedded microprocessor	U1	SG-BGA-6004	SPEAR300; STmicroelectronics Spear330
Power distribution switch	U4	SO8	ST2052; STm Current limited power distribution switches
RS-232 driver and receiver	U12	SO16	ST3232C; STm RS-232 driver and receiver
Voltage regulator	U9	SOT223	ST LD1117S25TR; STm low drop fixed positive voltage regulator 2.5V 800mA
Reset circuit	U7	SOT143-4	STM811; STm Reset generator and power monitor 3.3V SOT143-4
Voltage regulator	U10	VFQFPN-48	ST PM6641; STm DDR2/3 Voltage Regulator 48pin VFQFPN
Connector	J5 J6 J7 J8 J9	2X1-2.54-MD	STRIP-2X1-2.54-MD; Strip vertical male 2X1 2.54mm
Connector	J22	2X2-2.54-MD	STRIP-2X2-2.54-MD; Strip vertical male 2X2 2.54mm
Connector	J20 J21	3X1-2.54-MD	STRIP-3X1; Strip vertical male 3X1 2.54mm
Overvoltage protection	U16	TDFN-10	ST STBP120C; STm overvoltage protection device Vout max 5.5V
ESD protection circuit	U13 U14 U15	SOT23-6L	ST USBLC6-2SC6; STm USB 2.0 ESD protections
Switch	P1	SW-PB-SMD6x6.6	SW-PB-SMD; Mechanical key switch SMD 6x6.6mm h4.3mm
Connector	J2	USB-A-RA-DB	USB A-TYPE RA DOUBLE; USB double A-type connector right angle
Connector	J1	USB-B-RA-1	USB B-TYPE RA SH; USB B-type connector right angle
Ferrite bead	FB1 FB2	0805	WURTH 742792023; Ferrite Wurth 742792023 SMD 500mA

6 Schematics

Figure 5. Schematic interconnections

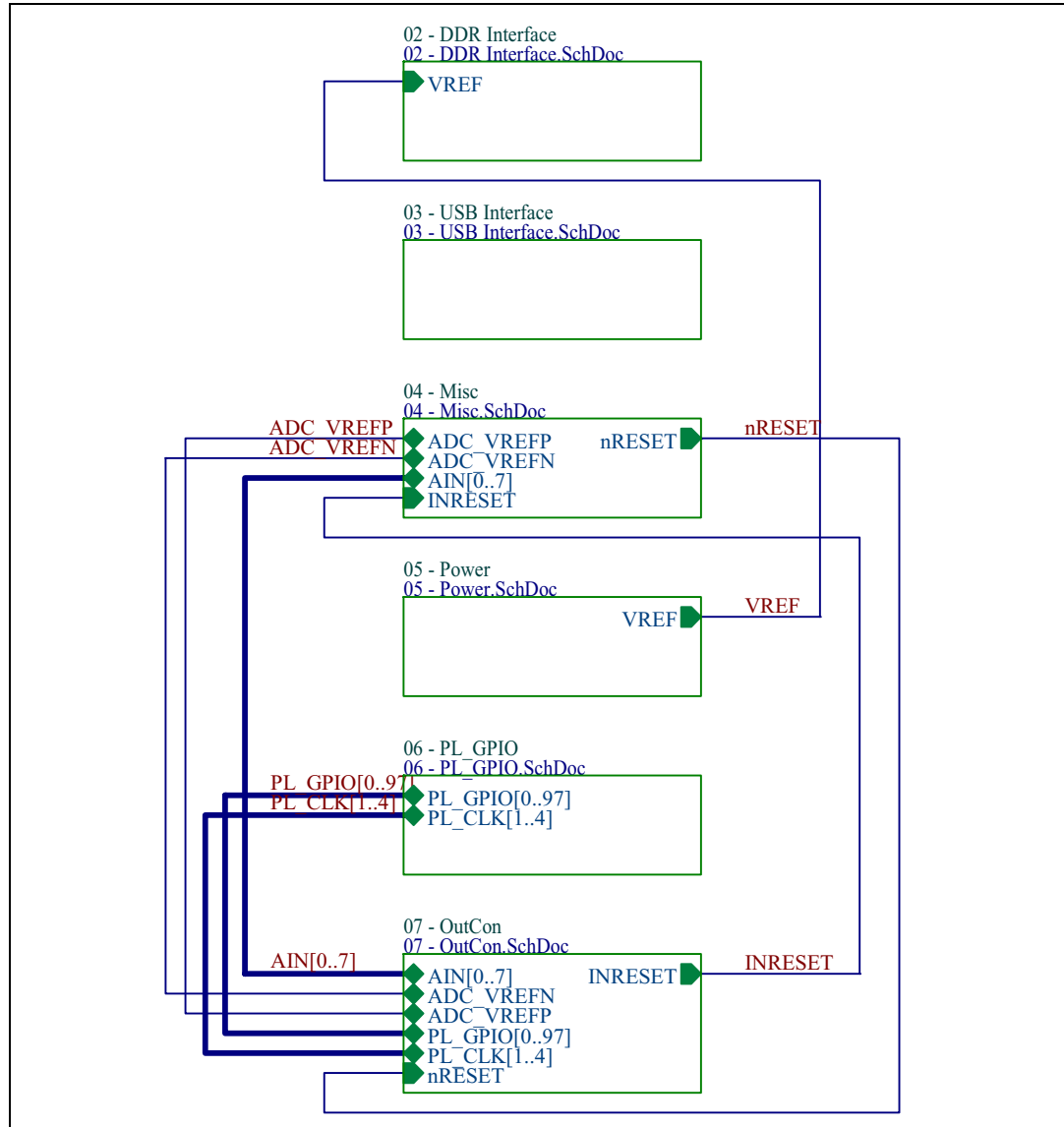

In [Figure 5](#):

- 02: DDR2 interface and power
- 03: USB interface
- 04: Miscellaneous (serial flash, RTC power, boot options, JTAG, reset)
- 05: Power supply
- 06: PL_GPIO interface, extended boot options
- 07: Daughterboard and UART connectors



Figure 6. DDR interface schematic

Doc ID 18124 Rev 1

23/38

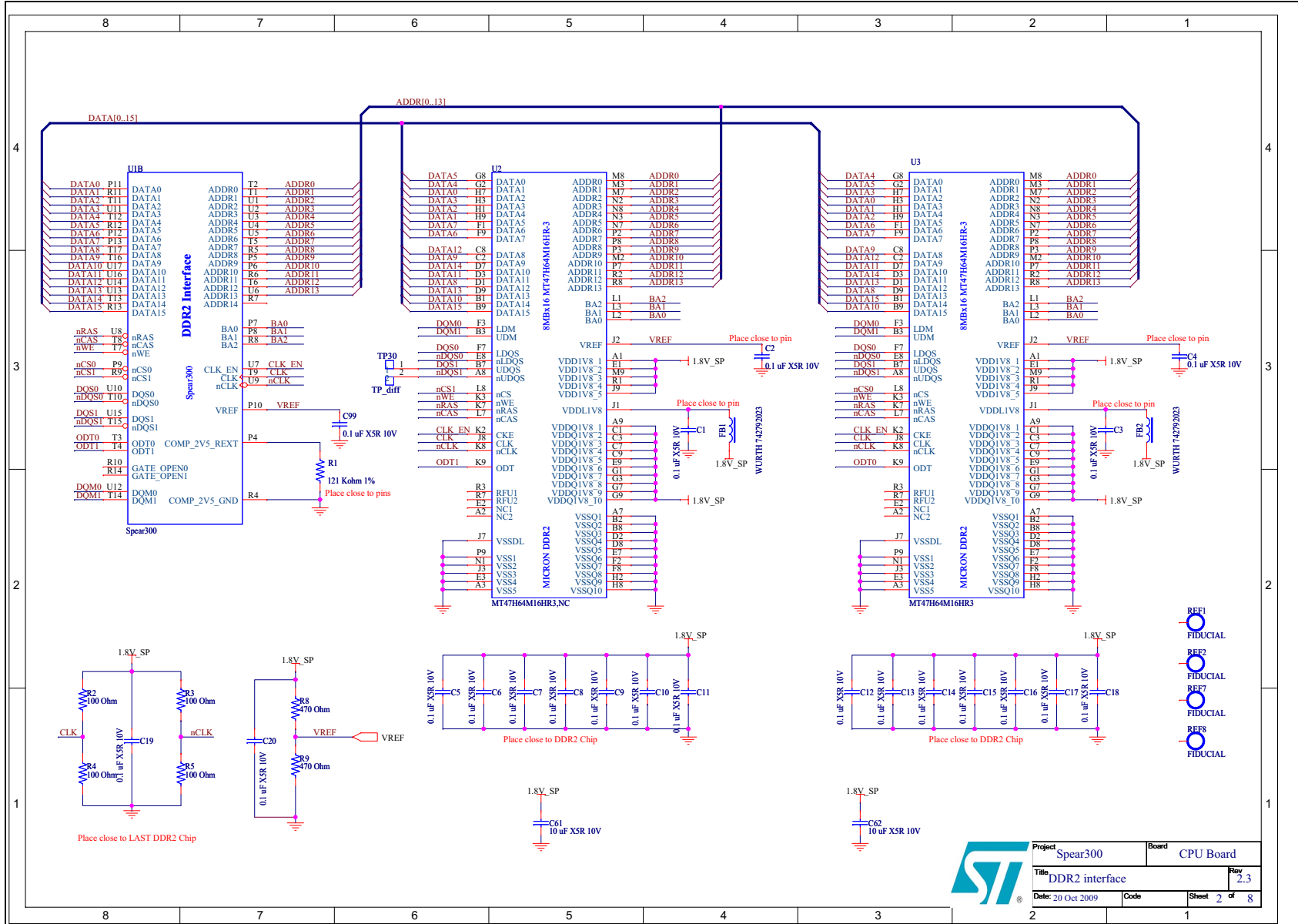

UM1015

Schematics



Figure 7. USB interface schematic

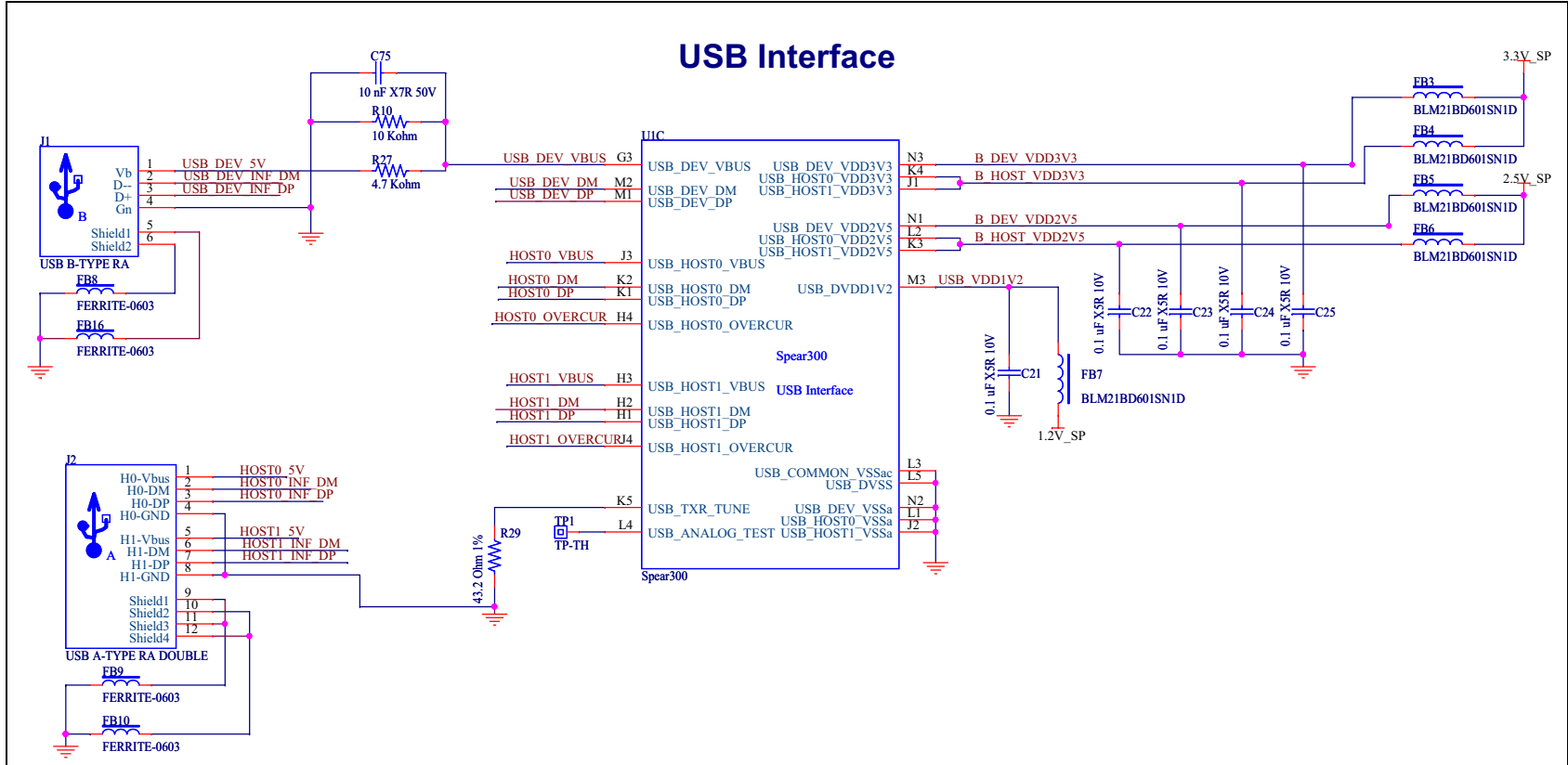

Figure 8. USB power and optional part schematic

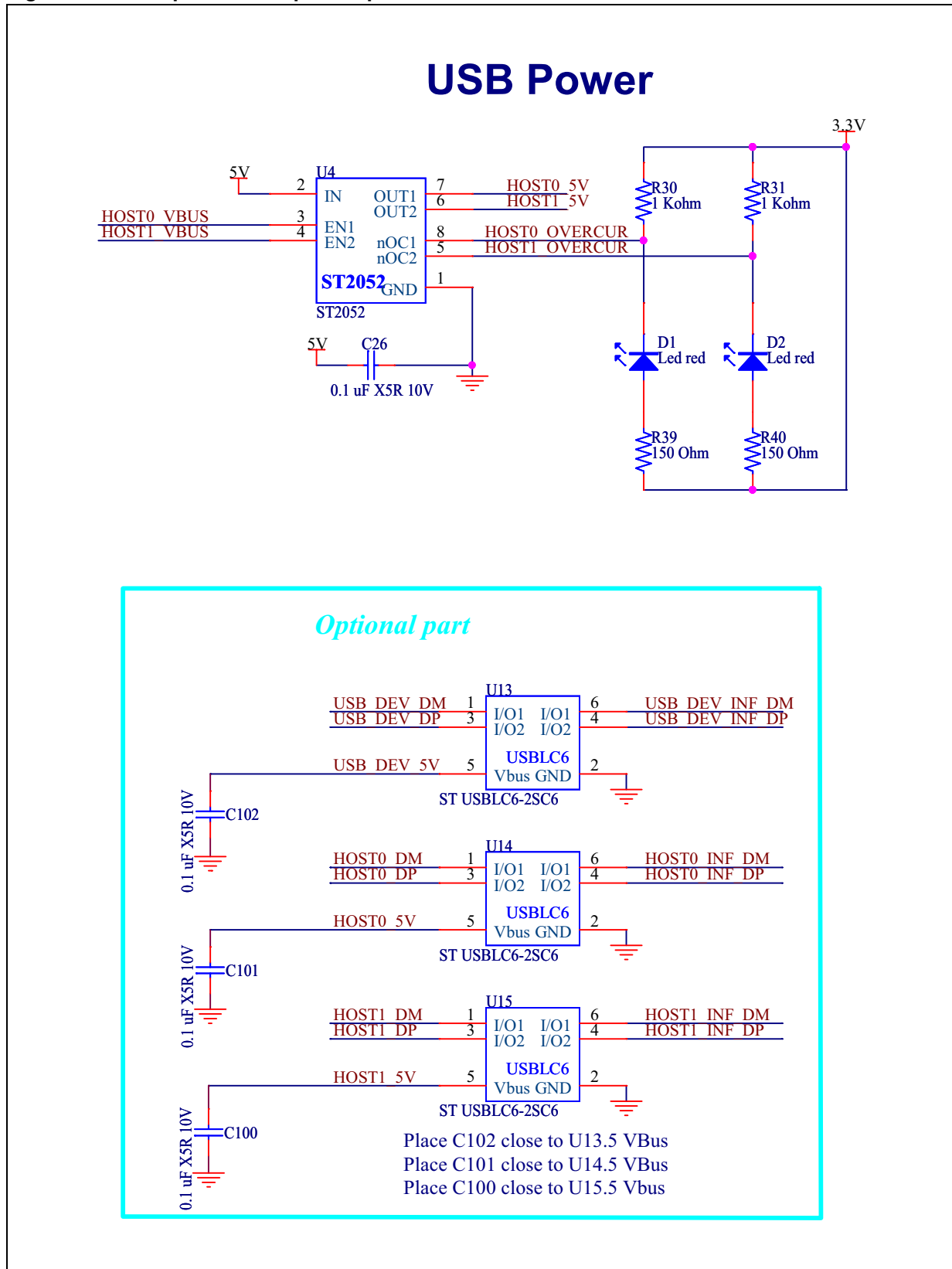
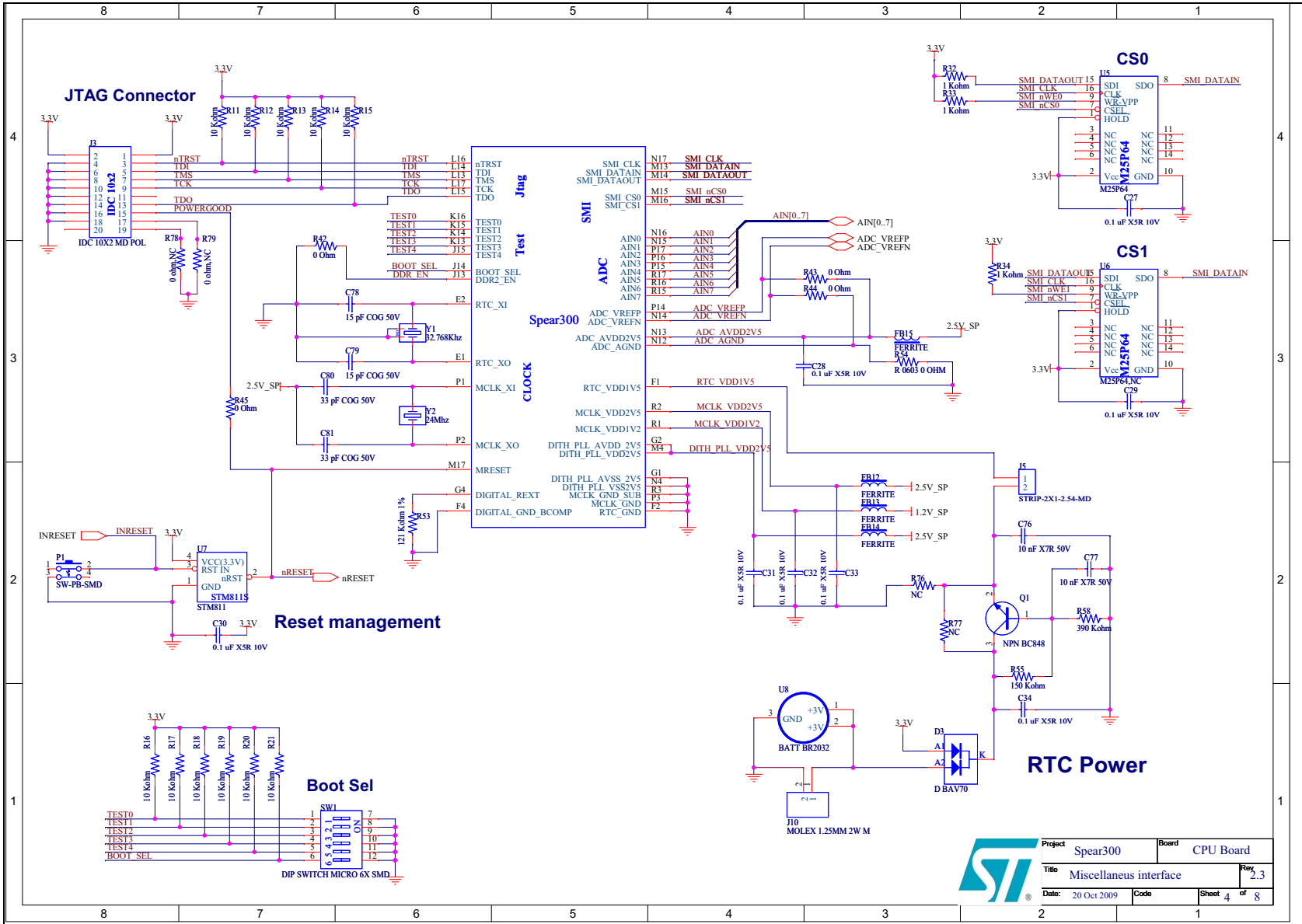



Figure 9. Miscellaneous interfaces schematic



Project	Spear300	Board	CPU Board
Title	Miscellaneous interface	Rev	2.3
Date:	20 Oct 2009	Code	Sheet 4 of 8



Figure 10. Power supply schematic

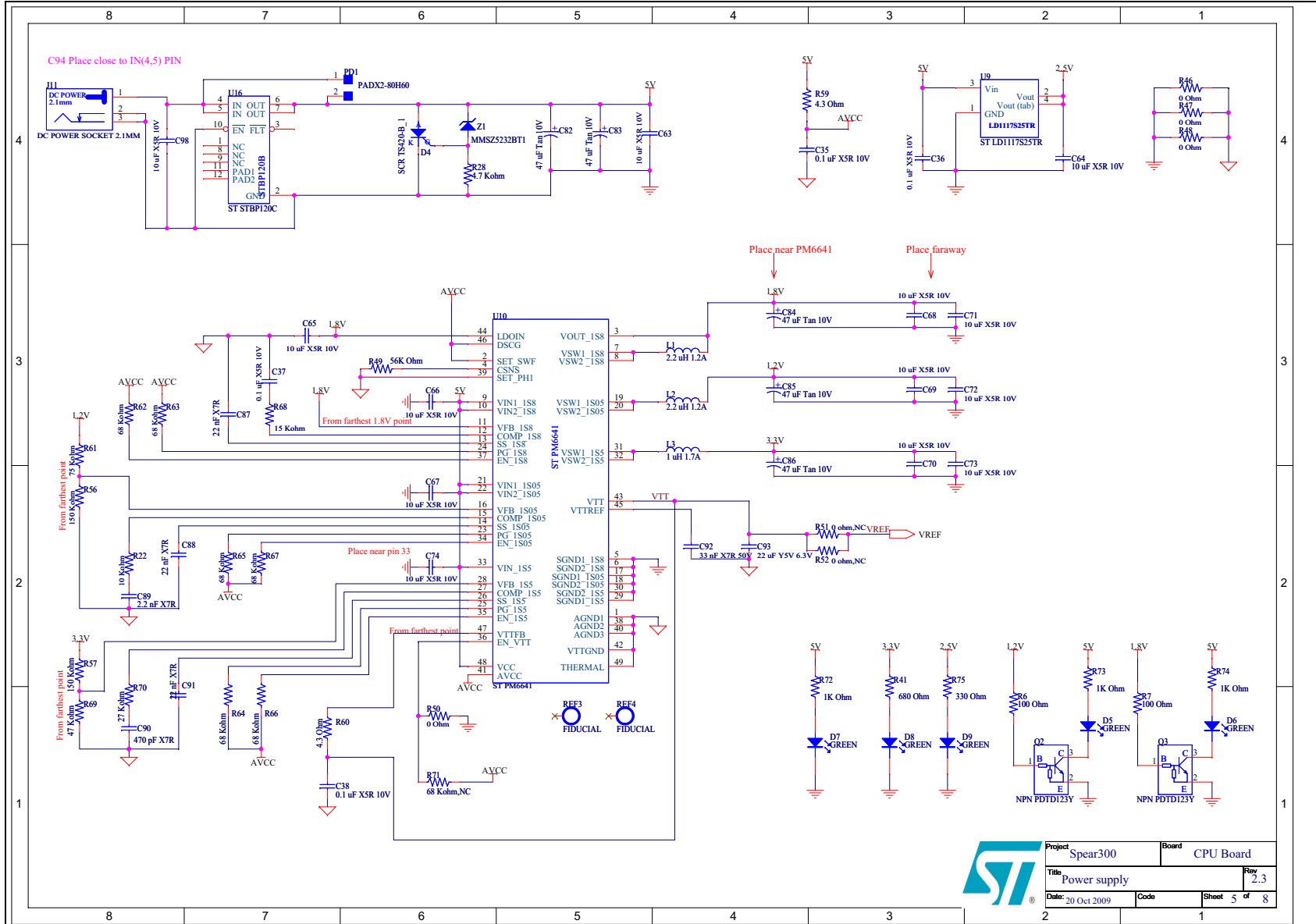

Doc ID 18124 Rev 1

27/38

UM1015

Schematics



Figure 11. Customization interface schematic

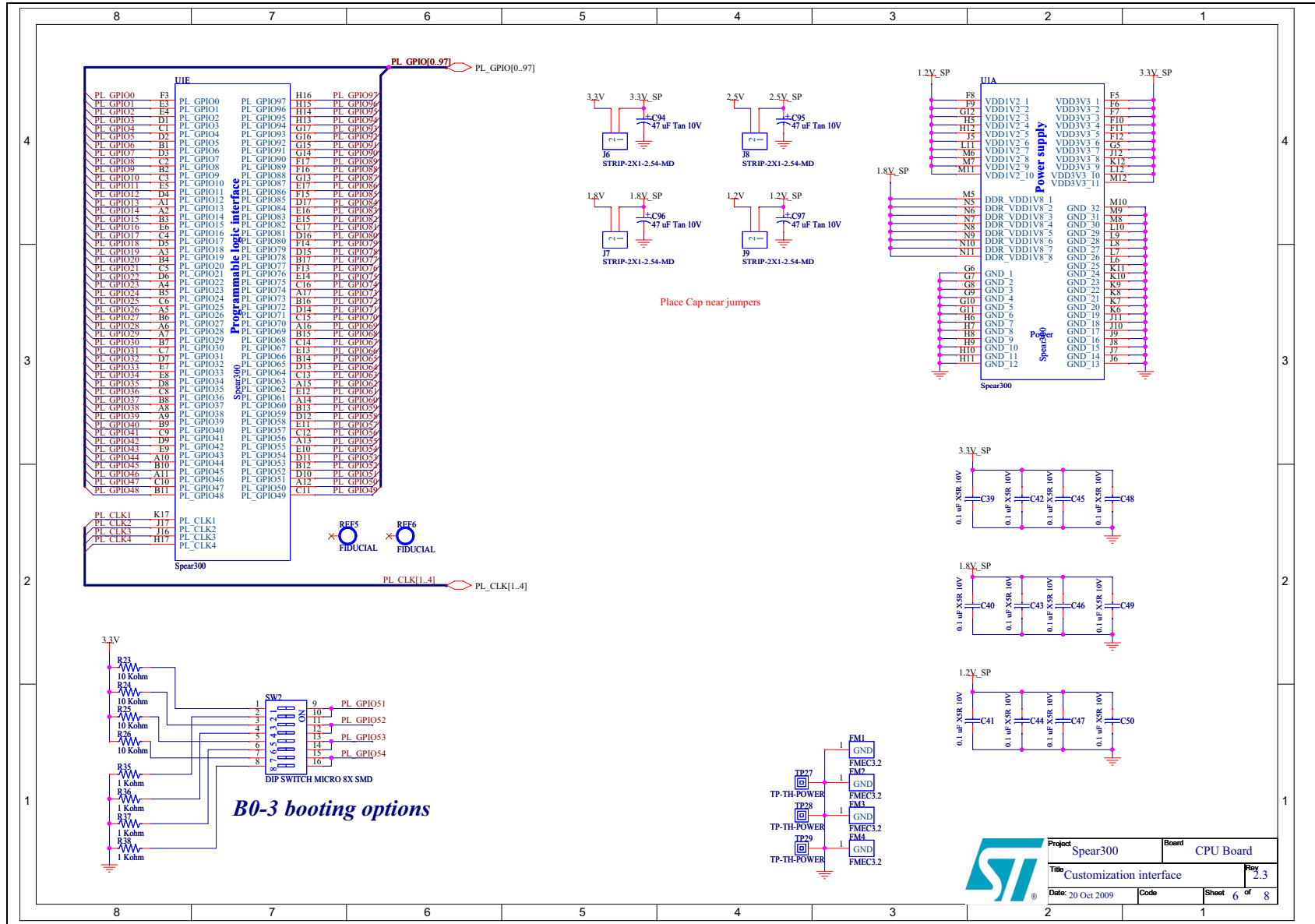

Project	Spear300	Board	CPU Board
Title	Customization interface		Rev 2.3
Date: 20 Oct 2009	Code	Sheet 6 of 8	



Figure 12. Daughterboard interface schematic

Doc ID 18124 Rev 1

29/38

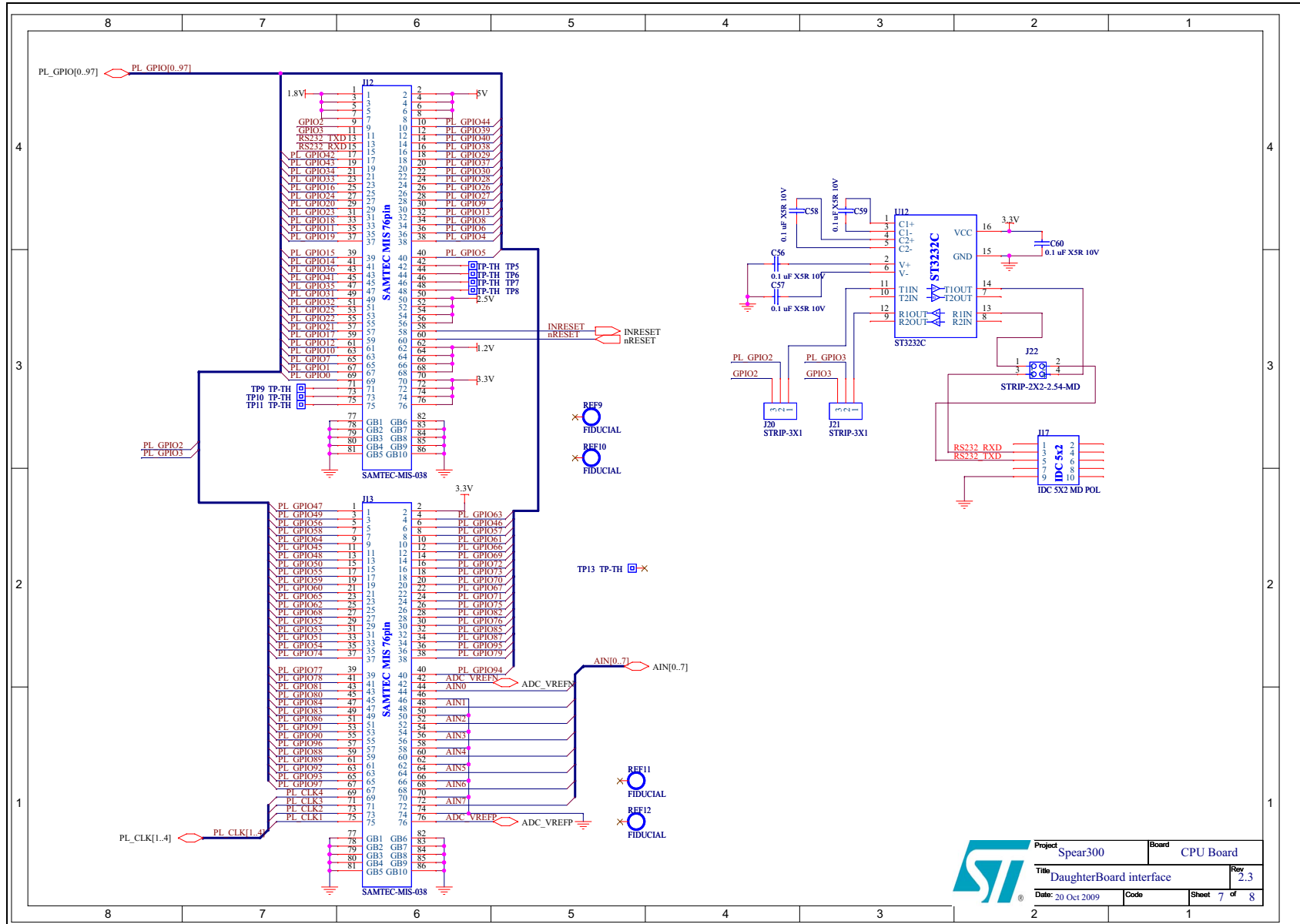

Project	Spear300	Board	CPU Board
Title	DaughterBoard interface		Rev 2.3
Date:	20 Oct 2009	Code	Sheet 7 of 8

UM1015

Schematics



Figure 13. Schematic revision history

Revision History			Revision History		
Revision	Descriptions	Date	Revision	Descriptions	Date
1.0	Initial release	20 May 2009	2.0	Change R49 Value to 56K ohm	23 Sep 2009
1.1	C78, C79 : connected to GND instead of 2.5V Add signal nRESET to daughter-board connectors (pinout to be defined) Add three optionals USBLC6 (U13, U14, U15) for ESD protection Add optional STBP120B (U16) for overvoltage protection Add two Spare Resistor for RTC Power (R76, R77) Add four 3.2mm mechanical holes Add two GND pins on 32.768Khz oscillator for PCB footprint Changed daughter-board connectors (Tyco MICTOR instead Samtec QTH) Made some cosmetic changes	28 May 2009	2.1	Add TP30 for DQS1 test; Add J22 for serial cable jumper ; Use NC for no pop components	16 Oct 2009
1.2	Changed daughter-board connectors (Samtec MIS instead Tyco MICTOR)	10 June 2009	2.2	Change R8 and R9 to "470 ohm" (remove NC), and R51 and R52 to "0 ohm,NC"	20 Oct 2009
1.3	Add four 47uF capacitor (C94, C95, C96, C97)	25 June 2009	2.3	Made some cosmetic changes	20 Oct 2009
1.4	Remove UART Solution 1 at Page 7 Remove JTAG alternativ Optional part at Page 4 Add a 10uF capacitor at input pot of STBP120, C98 Add two net: RS232_RXD and RS232_TXD at Page 7 U12-pin 14 and U12-pin13, these two net are connected to Pins40 and Pins42 of J13, Remove Test Point TP3 and TP4 Change footprint of D4(TS420-B), from DO-214AC to DPAK Add C99 0.1uF/6402 capacitor to Spare300 VREF pin Add R78 0ohm resistor to Pin17 of J3 JTAG Port, and another pad be connected to GND Add R79 0ohm resistor to Pin19 of J3 JTAG Port, and another pad be connected to GND Add GND to C94, C95,C96,C97	03 July 2009			
1.5	FB8 is only connected to PIN 6 of J1 at Page3 Add a FB16, FB16 is connected to PIN 5 of J1 at Page3 FB9 is connected to PIN 9 and PIN 11 of J2 at Page3 FB10 is connected to PIN 10 and PIN 12 of J2 at Page3	03 July 2009			
1.5.1	Swap U2 and U3 data signals for better pcb routing at Page2 Swap Socket J12 and J13 signals and add four 1.8V power pins to J12 at Page7 R11-R21 pull up to 3.3V (change from 3.3V_SP)at Page4 D3 Pin.A1 connect to 3.3V (change from 3.3V_SP)at Page4	10 July 2009			
1.6	Change all "Motherboard" to "CPU Board" Aupdate Fiducial (REF*) symbol.	17 July 2009			
1.7	Pull down U10.4 CSNS to AGND Connect U10.39 SET_PH1 to AGND	21 July 2009			
1.8	Change U13.5 net to USB_DEV_5V, Add C102 to Vbus pin Change U14.5 net to HOST0_5V, Add C101 to Vbus pin Change U15.5 net to HOST1_5V, Add C100 to Vbus pin Modify USB ESD circuit design, insert ESD IC into USB signals: DM and DP, include USB DEV and Two USB Host	23 July 2009			
1.9	Pull up R61 to 1.2V Change RS232-TXD net to J17.5 pin Change RS232-RXD net to J17.3 pin Change R72,R73,R74 value to 1K ohm Change R41 value to 680 ohm Change R75 value to 330 ohm	10 Sep 2009			



Project	Spear300	Board	CPU Board
Title	Release note		Rev 2.3
Date:	20 Oct 2009	Code	Sheet 8 of 8

7 Board layout

Figure 14. SPEAr320 CPU evaluation board layout (top view)

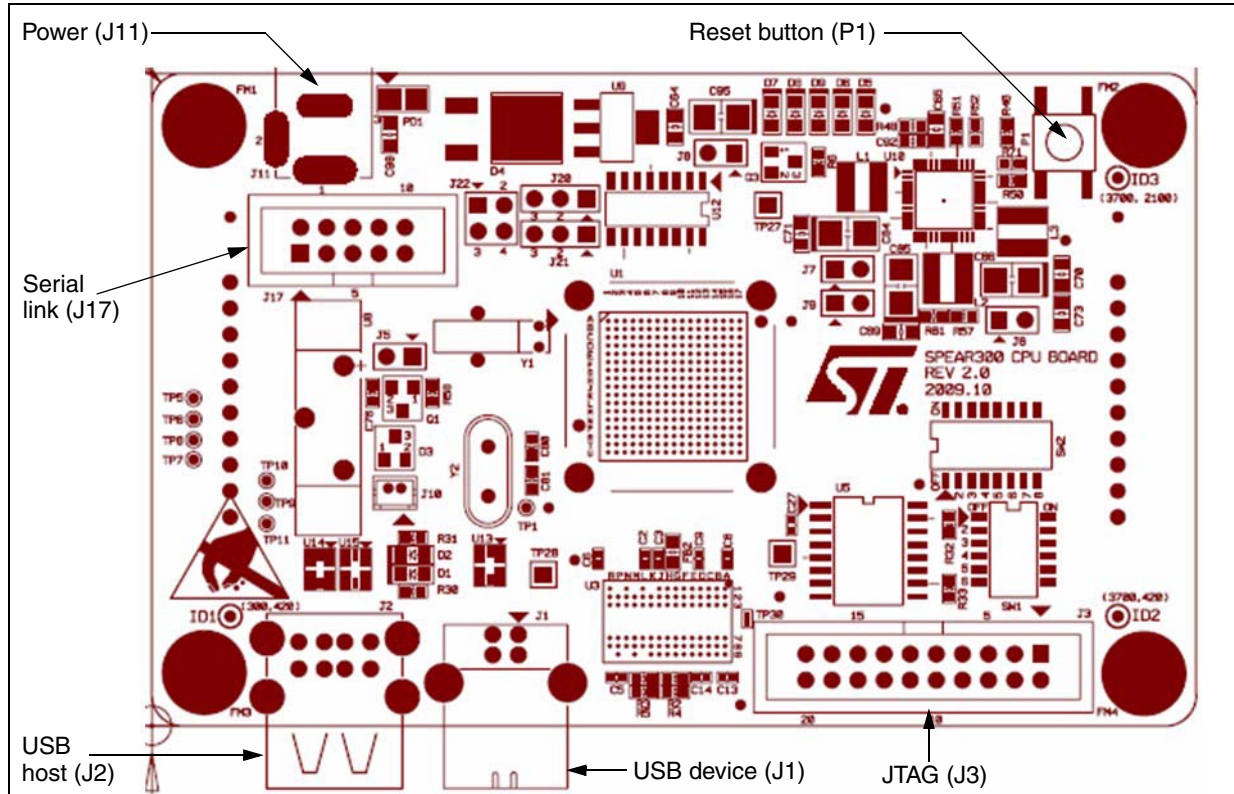
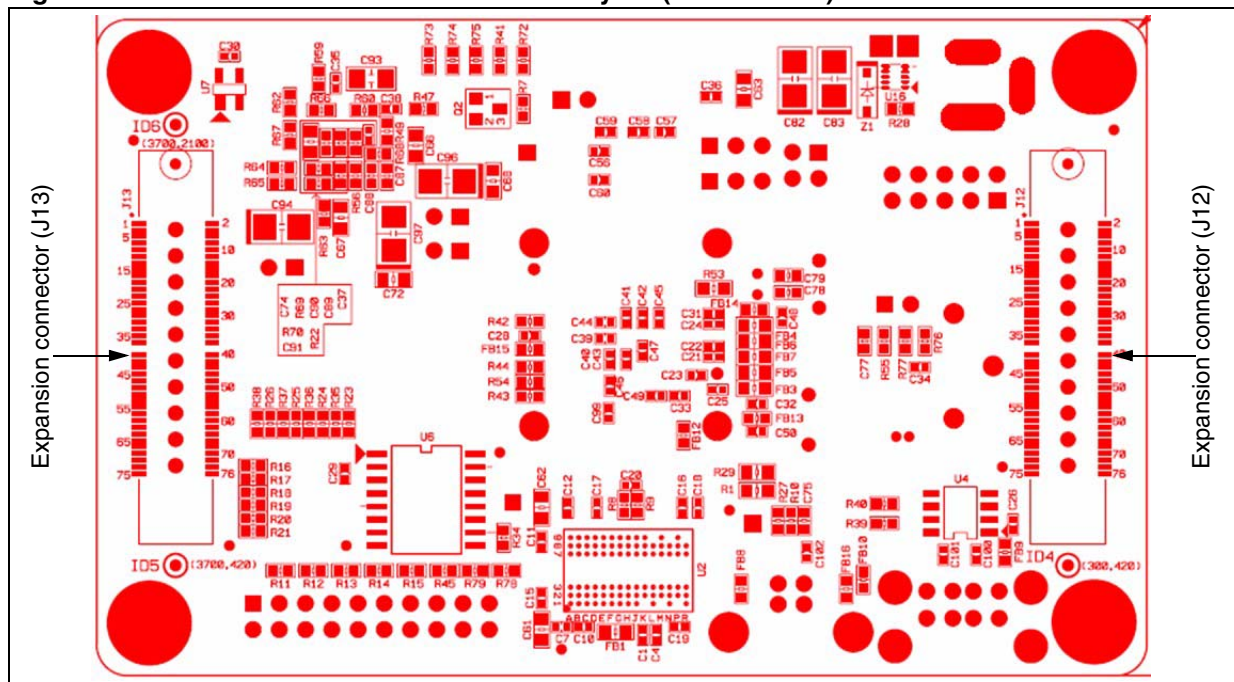

Figure 15. SPEAr320 CPU evaluation board layout (bottom view)



8 Revision history

8.1 Hardware revision history

Revision 2.0 SPEAr320 CPU evaluation boards are documented in revision 1 of the EVALSPEAr320CPU user manual.

Earlier board revisions are documented in UM0842, the EVALSPEAr320PLC user manual.

8.2 Document revision history

Table 9. Document revision history

Date	Revision	Changes
22-Oct-2010	1	Initial release.

Appendix A License agreements

DEMO PRODUCT LICENSE AGREEMENT

By using this Demonstration Product, You are agreeing to be bound by the terms and conditions of this agreement. Do not use this Demonstration Product until You have read and agreed to the following terms and conditions. The use of the Demonstration Product implies automatically the acceptance of the following terms and conditions.

LICENSE. STMicroelectronics ("ST") grants You the right to use the enclosed demonstration board offering limited features only to evaluate and test ST products, including any incorporated and/or accompanying demo software, components and documentation identified with the order code "EVALSPEAR320CPU" (collectively, the "Demo Product") solely only for your evaluation and testing purposes. The Demo Product shall not be, in any case, directly or indirectly assembled as a part in any production of Yours as it is solely developed to serve demonstration purposes and has no direct function and is not a finished product. Certain demo software included with the Demo Product may be covered under a separate accompanying end user license agreement, in which case the terms and conditions of such end user license agreement shall apply to that demonstration software.

DEMO PRODUCT STATUS. The Demo Product is offering limited features allowing You only to evaluate and test the ST products. You are not authorized to use the Demo Product in any production system, and may not be offered for sale or lease, or sold, leased or otherwise distributed. If the Demo Product is incorporated in a demonstration system, the demonstration system may be used by You solely for your evaluation and testing purposes. Such demonstration system may not be offered for sale or lease or sold, leased or otherwise distributed and must be accompanied by a conspicuous notice as follows: "This device is not, and may not be, offered for sale or lease, or sold or leased or otherwise distributed".

OWNERSHIP AND COPYRIGHT. Title to the Demo Product, demo software, related documentation and all copies thereof remain with ST and/or its licensors. You may not remove the copyrights notices from the Demo Product. You may make one (1) copy of the software for back-up or archival purposes provided that You reproduce and apply to such copy any copyright or other proprietary rights notices included on or embedded in the demonstration software. You agree to prevent any unauthorized copying of the Demo Product, demonstration software and related documentation.

RESTRICTIONS. You may not sell, assign, sublicense, lease, rent or otherwise distribute the Demo Product for commercial purposes (unless you are an authorized ST distributor provided that all the other clauses of this DEMO PRODUCT LICENSE AGREEMENT shall apply entirely), in whole or in part, or use Demo Product in production system. Except as provided in this Agreement or in the Demo Product's documentation, You may not reproduce the demonstration software or related documentation, or modify, reverse engineer, de-compile or disassemble the demonstration software, in whole or in part.

You warrant to ST that the Demo Product will be used and managed solely and exclusively in a laboratory by skilled professional employees of Yours with proven expertise in the use and management of such products and that the Demo Product shall be used and managed according to the terms and conditions set forth in the related documentation provided with the Demo Product.

According to European Semiconductor Industry Association (ESIA) letter, "ESIA Response on WEEE Review (May 2008) of the Directive 2002/96/EC on Waste Electrical and Electronic Equipment (WEEE)"; Semiconductor products and evaluation & demonstration boards are not in the scope of the Directive 2002/96/EC of the European Parliament and of the Council on waste electrical and electronic equipment (WEEE). Consequently aforementioned products do not have to be registered nor are they subject to the subsequent obligations.

NO WARRANTY. The Demo Product is provided "as is" and "with all faults" without warranty of any kind expressed or implied. ST and its licensors expressly disclaim all warranties, expressed, implied or otherwise, including without limitation, warranties of merchantability, fitness for a particular purpose and non-infringement of intellectual property rights. ST does not warrant that the use in whole or in part of the Demo Product will be interrupted or error free, will meet your requirements, or will operate with the combination of hardware and software selected by You. You are responsible for determining whether the Demo Product will be suitable for your intended use or application or will achieve your intended results.

ST shall not have any liability in case of damages, losses, claims or actions anyhow caused from combination of the Demo Product with another product, board, software or device.

ST has not authorized anyone to make any representation or warranty for the Demo Product, and any technical, applications or design information or advice, quality characterization, reliability data or other services provided by ST shall not constitute any representation or warranty by ST or alter this disclaimer or warranty, and in no additional obligations or liabilities shall arise from ST's providing such information or services. ST does not assume or authorize any other person to assume for it any other liability in connection with its Demo Products.

All other warranties, conditions or other terms implied by law are excluded to the fullest extent permitted by law.

LIMITATION OF LIABILITIES. In no event ST or its licensors shall be liable to You or any third party for any indirect, special, consequential, incidental, punitive damages or other damages (including but not limited to, the cost of labour, re-qualification, delay, loss of profits, loss of revenues, loss of data, costs of procurement of substitute goods or services or the like) whether based on contract, tort, or any other legal theory, relating to or in connection with the Demo Product, the documentation or this Agreement, even if ST has been advised of the possibility of such damages. In no event shall ST's

aggregate liability to You or any third party under this agreement for any cause action, whether based on contract, tort, or any other legal theory, relating to or in connection with the Demo Product, the documentation or this agreement shall exceed the purchase price paid for the Demo Product if any.

TERMINATION. ST may terminate this license at any time if You are in breach of any of its terms and conditions. Upon termination, You will immediately destroy or return all copies of the demo software and documentation to ST.

APPLICABLE LAW AND JURISDICTION. In case of dispute and in the absence of an amicable settlement, the only competent jurisdiction shall be the Courts of Geneva, Switzerland. The applicable law shall be the law of Switzerland. The UN Convention on contracts for the International Sales of Goods shall not apply to these General Terms and Conditions of Sale.

SEVERABILITY. If any provision of this agreement is or becomes, at any time or for any reason, unenforceable or invalid, no other provision of this agreement shall be affected thereby, and the remaining provisions of this agreement shall continue with the same force and effect as if such unenforceable or invalid provisions had not been inserted in this Agreement.

WAIVER. The waiver by either party of any breach of any provisions of this Agreement shall not operate or be construed as a waiver of any other or a subsequent breach of the same or a different provision.

RELATIONSHIP OF THE PARTIES. Nothing in this Agreement shall create, or be deemed to create, a partnership or the relationship of principal and agent or employer and employee between the Parties. Neither Party has the authority or power to bind, to contract in the name of or to create a liability for the other in any way or for any purpose.

RECYCLING. The Demo Product is not to be disposed as an urban waste. At the end of its life cycle, differentiated waste collection must be followed, as stated in the directive 2002/96/EC.

In all the countries belonging to the European Union (EU Dir. 2002/96/EC) and those following differentiated recycling, the Demo Product is subject to differentiated recycling at the end of its life cycle, therefore:

It is forbidden to dispose the Demo Product as an undifferentiated waste or with other domestic wastes. Consult the local authorities for more information on the proper disposal channels.

It is mandatory to sort the demo product and deliver it to the appropriate collection centers, or, when possible, return the demo product to the seller.

An incorrect Demo Product disposal may cause damage to the environment and is punished by the law.

10-Nov-2008

SOFTWARE LICENSE AGREEMENT

This Software License Agreement ("Agreement") is displayed for You to read prior to downloading and using the Licensed Software. If you choose not to agree with these provisions, do not download or install the enclosed Licensed Software and the related documentation and design tools. By using the Licensed Software, You are agreeing to be bound by the terms and conditions of this Agreement. Do not use the Licensed Software until You have read and agreed to the following terms and conditions. The use of the Licensed Software implies automatically the acceptance of the following terms and conditions.

DEFINITIONS

Licensed Software: means the enclosed demonstration software and all the related documentation and design tools licensed in the form of object and/or source code as the case may be.

Product: means a product or a system that includes or incorporates solely and exclusively an executable version of the Licensed Software and provided further that such Licensed

Software executes solely and exclusively on ST products.

LICENSE

STMicroelectronics ("ST") grants You a non-exclusive, worldwide, non-transferable (whether by assignment, law, sublicense or otherwise), revocable, royalty-free limited license to:

(i) make copies, prepare derivatives works, display internally and use internally the source code version of the Licensed Software for the sole and exclusive purpose of developing executable versions of such Licensed Software only for use with the Product;

(ii) make copies, prepare derivatives works, display internally and use internally object code versions of the Licensed Software for the sole purpose of designing, developing and manufacturing the Products;

(iii) make, use, sell, offer to sell, import or otherwise distribute Products.

OWNERSHIP AND COPYRIGHT

Title to the Licensed Software, related documentation and all copies thereof remain with ST and/or its licensors. You may not remove the copyrights notices from the Licensed Software.

You may make one (1) copy of the Licensed Software for back-up or archival purposes provided that You reproduce and apply to such copy any copyright or other proprietary rights notices included on or embedded in the Licensed Software. You agree to prevent any unauthorized copying of the Licensed Software and related documentation.

RESTRICTIONS

Unless otherwise explicitly stated in this Agreement, You may not sell, assign, sublicense, lease, rent or otherwise distribute the Licensed for commercial purposes, in whole or in part purposes (unless you are an authorized ST distributor provided that all the other clauses of this DEMO PRODUCT LICENSE AGREEMENT shall apply entirely).

You acknowledge and agree that any use, adaptation translation or transcription of the

Licensed Software or any portion or derivative thereof, for use with processors manufactured by or for an entity other than ST is a material breach of this Agreement and requires a separate license from ST. No source code and/or object code relating to and/or based upon Licensed Software is to be made available by You to any third party for whatever reason.

You acknowledge and agrees that the protection of the source code of the Licensed Software warrants the imposition of security precautions and You agree to implement reasonable security measures to protect ST's proprietary rights in the source code of the Licensed Software. You shall not under any circumstances copy, duplicate or otherwise reproduce the source code of the Licensed Software in any manner, except as reasonably necessary to exercise Your rights hereunder and make one back-up copy. You are granted the right to make one archival or backup copy of the source code of the Licensed Software, which copy shall be marked as an archival copy and as the confidential information of ST. Access to the source code of the Licensed Software shall be restricted to only those of Your employees with a need-to-know for the purpose of this Agreement.

You will not under any circumstances permit the source code of the Licensed Software in any form or medium (including, but not limited to, hard copy or computer print-out) to be removed from your official premises as you have informed us. The source code of the Licensed Software must remain inside your official premises, as you have informed us. You will lock the source code of the Licensed Software and all copies thereof in a secured storage inside your official premises at all times when the source code of the Licensed Software is not being used as permitted under this Agreement.

You will inform all Your employees who are given access to the source code of the Licensed Software of the foregoing requirements, and You will take all reasonable precautions to ensure and monitor their compliance with such requirements. You agree to promptly notify ST in the event of a violation of any of the foregoing, and to cooperate with ST to take any remedial action appropriate to address the violation. You shall keep accurate records with respect to its use of the source code of the Licensed Software. In the event ST demonstrates to You a reasonable belief that the source code of the Licensed Software has been used or distributed in violation of this Agreement, ST may by written notification request certification as to whether such unauthorized use or distribution has occurred. You shall reasonably cooperate and assist ST in its determination of whether there has been unauthorized use or distribution of the source code of the Licensed Software and will take appropriate steps to remedy any unauthorized use or distribution.

You agree that ST shall have the right (where ST reasonably suspects that the terms and conditions of this Agreement with reference to Restriction clause have not been complied with) upon reasonable notice to enter Your official premises in order to verify your compliance with this Restriction clause.

NO WARRANTY

The Licensed Software is provided "as is" and "with all faults" without warranty of any kind expressed or implied. ST and its licensors expressly disclaim all warranties, expressed, implied or otherwise, including without limitation, warranties of merchantability, fitness for a particular purpose and non-infringement of intellectual property rights. ST does not warrant that the use in whole or in part of the Licensed Software will be interrupted or error free, will meet your requirements, or will operate with the combination of hardware and software selected by You.

You are responsible for determining whether the Licensed Software will be suitable for your intended use or application or will achieve your intended results. ST has not authorized anyone to make any representation or warranty for the Licensed Software, and any technical, applications or design information or advice, quality characterization, reliability data or other services provided by ST shall not constitute any representation or warranty by ST or alter this disclaimer or warranty, and in no additional obligations or liabilities shall arise from ST's providing such information or services. ST does not assume or authorize any other person to assume for it any other liability in connection with its Licensed Software.

Nothing contained in this Agreement will be construed as:

- (i) a warranty or representation by ST to maintain production of any ST device or other hardware or software with which the Licensed Software may be used or to otherwise maintain or support the Licensed Software in any manner; and
- (ii) a commitment from ST and/or its licensors to bring or prosecute actions or suits against

third parties for infringement of any of the rights licensed hereby, or conferring any rights to bring or prosecute actions or suits against third parties for infringement. However, ST has the right to terminate this Agreement immediately upon receiving notice of any claim, suit or proceeding that alleges that the Licensed Software or your use or distribution of the Licensed

Software infringes any third party intellectual property rights.

All other warranties, conditions or other terms implied by law are excluded to the fullest extent permitted by law.

LIMITATION OF LIABILITIES

In no event ST or its licensors shall be liable to You or any third party for any indirect, special, consequential, incidental, punitive damages or other damages (including but not limited to, the cost of labour, re-qualification, delay, loss of profits, loss of revenues, loss of data, costs of procurement of substitute goods or services or the like) whether based on contract, tort, or any other legal theory, relating to or in connection with the Licensed Software, the documentation or this Agreement, even if ST has been advised of the possibility of such damages.

In no event shall ST's liability to You or any third party under this Agreement, including any claim with respect of any third party intellectual property rights, for any cause of action exceed

100 US\$. This section does not apply to the extent prohibited by law. For the purposes of this section, any liability of ST shall be treated in the aggregate.

TERMINATION

ST may terminate this license at any time if You are in breach of any of its terms and conditions. Upon termination, You will immediately destroy or return all copies of the software and documentation to ST.

APPLICABLE LAW AND JURISDICTION

In case of dispute and in the absence of an amicable settlement, the only competent jurisdiction shall be the Courts of Geneva, Switzerland. The applicable law shall be the law of Switzerland.

SEVERABILITY

If any provision of this agreement is or becomes, at any time or for any reason, unenforceable or invalid, no other provision of this agreement shall be affected thereby, and the remaining provisions of this agreement shall continue with the same force and effect as if such unenforceable or invalid provisions had not been inserted in this Agreement.

WAIVER

The waiver by either party of any breach of any provisions of this Agreement shall not operate or be construed as a waiver of any other or a subsequent breach of the same or a different provision.

RELATIONSHIP OF THE PARTIES

Nothing in this Agreement shall create, or be deemed to create, a partnership or the relationship of principal and agent or employer and employee between the Parties. Neither Party has the authority or power to bind, to contract in the name of or to create a liability for the other in any way or for any purpose.

Please Read Carefully:

Information in this document is provided solely in connection with ST products. STMicroelectronics NV and its subsidiaries ("ST") reserve the right to make changes, corrections, modifications or improvements, to this document, and the products and services described herein at any time, without notice.

All ST products are sold pursuant to ST's terms and conditions of sale.

Purchasers are solely responsible for the choice, selection and use of the ST products and services described herein, and ST assumes no liability whatsoever relating to the choice, selection or use of the ST products and services described herein.

No license, express or implied, by estoppel or otherwise, to any intellectual property rights is granted under this document. If any part of this document refers to any third party products or services it shall not be deemed a license grant by ST for the use of such third party products or services, or any intellectual property contained therein or considered as a warranty covering the use in any manner whatsoever of such third party products or services or any intellectual property contained therein.

UNLESS OTHERWISE SET FORTH IN ST'S TERMS AND CONDITIONS OF SALE ST DISCLAIMS ANY EXPRESS OR IMPLIED WARRANTY WITH RESPECT TO THE USE AND/OR SALE OF ST PRODUCTS INCLUDING WITHOUT LIMITATION IMPLIED WARRANTIES OF MERCHANTABILITY, FITNESS FOR A PARTICULAR PURPOSE (AND THEIR EQUIVALENTS UNDER THE LAWS OF ANY JURISDICTION), OR INFRINGEMENT OF ANY PATENT, COPYRIGHT OR OTHER INTELLECTUAL PROPERTY RIGHT.

UNLESS EXPRESSLY APPROVED IN WRITING BY AN AUTHORIZED ST REPRESENTATIVE, ST PRODUCTS ARE NOT RECOMMENDED, AUTHORIZED OR WARRANTED FOR USE IN MILITARY, AIR CRAFT, SPACE, LIFE SAVING, OR LIFE SUSTAINING APPLICATIONS, NOR IN PRODUCTS OR SYSTEMS WHERE FAILURE OR MALFUNCTION MAY RESULT IN PERSONAL INJURY, DEATH, OR SEVERE PROPERTY OR ENVIRONMENTAL DAMAGE. ST PRODUCTS WHICH ARE NOT SPECIFIED AS "AUTOMOTIVE GRADE" MAY ONLY BE USED IN AUTOMOTIVE APPLICATIONS AT USER'S OWN RISK.

Resale of ST products with provisions different from the statements and/or technical features set forth in this document shall immediately void any warranty granted by ST for the ST product or service described herein and shall not create or extend in any manner whatsoever, any liability of ST.

ST and the ST logo are trademarks or registered trademarks of ST in various countries.

Information in this document supersedes and replaces all information previously supplied.

The ST logo is a registered trademark of STMicroelectronics. All other names are the property of their respective owners.

© 2010 STMicroelectronics - All rights reserved

STMicroelectronics group of companies

Australia - Belgium - Brazil - Canada - China - Czech Republic - Finland - France - Germany - Hong Kong - India - Israel - Italy - Japan - Malaysia - Malta - Morocco - Philippines - Singapore - Spain - Sweden - Switzerland - United Kingdom - United States of America

www.st.com