

# TLM100 Tank Level Monitor

## User's Manual

Revision 1.1

Copyright © 2009 Maretron, LLP All Rights Reserved

Maretron, LLP  
9014 N. 23<sup>rd</sup> Ave #10  
Phoenix, AZ 85021  
<http://www.maretron.com>

Maretron Manual Part #: M002201

## **Revision History**

<b>Revision</b>	<b>Description</b>
1.0	Original document
1.1	Corrected typo in NMEA protocol PGN list

## Table of Contents

1	General .....	1
1.1	Introduction .....	1
1.2	Gasoline Tanks .....	1
1.3	Firmware Revision .....	1
1.4	Features .....	1
1.5	TLM100 Accessories .....	2
1.6	Quick Install .....	2
2	Installation .....	2
2.1	Unpacking the Box.....	2
2.2	Choosing a Mounting Location .....	2
2.3	Mounting the TLM100.....	3
2.3.1	Effect of Pitch and Roll on the TLM100.....	3
2.3.2	Use of an Airlock on Black Water Tanks .....	3
2.3.3	Mounting the TLM100 Sensor Component .....	3
2.3.4	Mounting the TLM100 Interface Component.....	7
2.4	Connecting the TLM100 .....	8
2.4.1	Connecting to NMEA 2000® Interface .....	8
3	Configuring the TLM100.....	9
3.1	Configuring Tank Type .....	9
3.2	Configuring Tank Number.....	9
3.3	Configuring Tank Capacity .....	9
3.4	Tank Depth or Custom Calibration.....	10
3.4.1	Tank Depth Programming .....	10
3.4.2	Custom Calibration.....	10
4	Maintenance.....	10
5	Troubleshooting .....	10
6	Technical Specifications.....	11
7	Technical Support .....	12
8	Maretron (2 Year) Limited Warranty .....	13

## **Table of Figures**

Figure 1 – TLM100 Mounting – SAE 5-Hole Bolt Pattern .....	4
Figure 2 – Mounting TLM100 to SAE 5-Hole Tank with Focus Tube .....	5
Figure 3 – TLM100 Mounting With Threaded Adapter.....	6
Figure 4 – Mounting TLM100 with Focus Tube on Threaded Tank Fitting.....	7
Figure 5 – TLM100 Connections .....	8
Figure 6 – NMEA 2000® Connector Face Views .....	9
Figure 7 – Troubleshooting Guide .....	11

## **Table of Appendices**

Appendix A – NMEA 2000® Interfacing.....	A1
--	----

## 1 General

### 1.1 Introduction

Congratulations on your purchase of the Maretron Tank Level Monitor (TLM100). Maretron has designed and built your monitor to the highest standards for years of reliable, dependable, and accurate service.

The TLM100 is used to sense levels of liquid tanks using ultrasonic technology and transmit the liquid levels over the NMEA 2000® network. This allows you to observe tank levels anywhere on the vessel where there is an NMEA 2000® compatible display such as the Maretron DSM250. The TLM100 is capable of sensing tanks up to 40" (1.02m) in depth. It can be used for diesel, fresh water, grey water, black water, and oil tanks. Unlike most tank senders that only work with rectangular tanks, the TLM100 can be calibrated for irregular tank shapes so you know the true level of your tanks. The TLM100 can be mounted on tanks with a SAE J1810 5-hole mounting pattern, or to tanks using 1.5" NPT or 1.25" BSP threaded openings via available adapters. The TLM100 has an optional airlock for black water applications to keep the face of the ultrasonic transmitter from fouling, and an optional focus tube to allow use on boats with planing hulls when the vessel spends a significant amount of time with the bow pitched up.

The Maretron TLM100 is designed to operate within the harsh demands of the marine environment. However, no piece of marine electronic equipment can function properly unless installed, calibrated, and maintained in the correct manner. Please read carefully and follow these instructions for installation, calibration, and usage of the Maretron TLM100 in order to ensure optimal performance.

### 1.2 Gasoline Tanks

The TLM100 is NOT intended for use in tanks containing gasoline. Use in tanks containing gasoline will void the product warranty.

### 1.3 Firmware Revision

This manual corresponds to TLM100 firmware revision 1.1.2.

### 1.4 Features

The Maretron TLM100 has the following features.

- NMEA 2000® Interface
- Integrated ultrasonic level sensor
- Can be used in tanks up to 40" deep
- SAE J1810 5-hole, 1.5" NPT, or 1.25" BSP Mounting
- Accommodates Irregularly Shaped Tanks with 16 Point Calibration
- 16 Programmable Tank Types Including Fuel, Fresh Water, Waste Water, Live Well
- Programmable Tank Number(s) Up to 16 per Tank Type
- Programmable Tank Capacity

## **1.5 TLM100 Accessories**

Maretron offers the following accessories for the TLM100:

- TA-5H-1.5NPT      1.5" NPT Displacement Hull Tank Adapter
- TA-5H-1.25BSP    1.25" BSP Displacement Hull Tank Adapter
- TFT-5H            SAE 5-Bolt Pattern Non-Displacement Hull Focus Tube
- TFT-1.5NPT       1.5" NPT Non-Displacement Hull Focus Tube
- TFT-1.25BSP      1.25" BSP Non-Displacement Hull Focus Tube
- TAL-5H            SAE 5-Bolt Pattern Black Water Airlock
- TAL-1.5NPT       1.5" NPT Black Water Airlock
- TAL-1.25BSP      1.25" BSP Black Water Airlock

## **1.6 Quick Install**

Installing the Maretron TLM100 involves the following steps. Please refer to the individual sections for additional details.

1. Unpack the Box (Section 2.1)
2. Choose a Mounting Location (Section 2.2)
3. Connect the TLM100 (Section 2.3)
4. Configure or Program the Tank Type (Section 3.1)
5. Configure or Program the Tank Number (Section 3.2)
6. Configure or Program Tank Capacity (Section 3.3)
7. Configure for Tank Depth and Shape
  - Configure or Program the Tank Depth (Section 3.4.1)
  - Custom Calibration (Section 3.4.2)

## **2 Installation**

### **2.1 Unpacking the Box**

When unpacking the box containing the Maretron TLM100, you should find the following items.

- 1 – TLM100 Tank Level Monitor
- 1 – TLM100 Gasket
- 1 – TLM100 User's Manual
- 1 – Warranty Registration Card

If any of these items are missing or damaged, please contact Maretron.

### **2.2 Choosing a Mounting Location**

The primary function of the TLM100 is to sense levels of liquid in tanks using ultrasonic technology and transmit this information over NMEA 2000<sup>®</sup> network so that tank level information can be viewed anywhere on the vessel where there is an NMEA 2000<sup>®</sup> compatible display.

## 2.3 Mounting the TLM100

The TLM100 tank level monitor consists of two parts: 1) the sensor, which mounts onto the top of the tank and contains the ultrasonic fuel measurement components, and 2) the interface, which converts the measured data into NMEA 2000® format and transmits the data over the NMEA 2000® network.

### 2.3.1 Effect of Pitch and Roll on the TLM100

Assuming that the TLM100 sensor component is mounted on a flat tank top, the TLM100 will operate correctly as long as the vessel does not experience pitch and/or roll in excess of 6° for an extended period of time. This can occur on a sailboat when the boat is heeled over, or on a powerboat with a non-displacement (planing) hull. Temporary pitch and roll due to wave motion and will not adversely affect tank level readings.

If you are in a sailing vessel or a powerboat with a non-displacement hull and will experience pitch and/or roll in excess of 6° for an extended period of time, you can install a Non-Displacement Hull Focus Tube below the sensor (please refer to Section 1.5 on page 2 for ordering information). This is a tube which mounts into the tank before the sensor and directs the ultrasonic waves down to the surface of the liquid and back. With a focus tube, the TLM100 will operate correctly as long as the vessel does not exceed 15° of pitch and/or roll for extended periods of time.

### 2.3.2 Use of an Airlock on Black Water Tanks

Maretron highly recommends the use of an airlock (please refer to Section 1.5 for information on available airlocks) in black water tank applications. Use of an airlock will prevent the face of the ultrasonic transducer from becoming fouled with tank contents, but will limit the minimum depth that the TLM100 can sense to the depth of the airlock component, as the liquid will not rise above the bottom of the airlock.

### 2.3.3 Mounting the TLM100 Sensor Component

The TLM100 comes from the factory ready to mount on a tank with the standard SAE J1810 5-Hole mounting pattern. Maretron offers adapters to allow mounting the TLM100 on a tank with a 1.5" NPT connection or a 1.25" BSP connection.

The mounting hole through which the TLM100 measures fluid level should be located as close to the center of the tank, both front-to-back and side-to-side, as possible. This will ensure maximum accuracy of reading in the event that the vessel experiences pitch and roll.

#### 2.3.3.1 Installation on a Tank with a SAE J1810 5-Bolt Fitting

To install the TLM100 on a tank with a SAE J1810 5-bolt fitting, place the gasket over the tank fitting so that the bolt holes line up. Place the TLM100 sensor component over the gasket so that the bolt holes line up. Insert the mounting bolts through the TLM100 sensor component and gasket into the tank fitting (the tank fitting may instead have studs installed, so in this case, install the nuts over the studs), and tighten them to a torque of 10-15 ft-lbs (13.6-20.3 N·m).

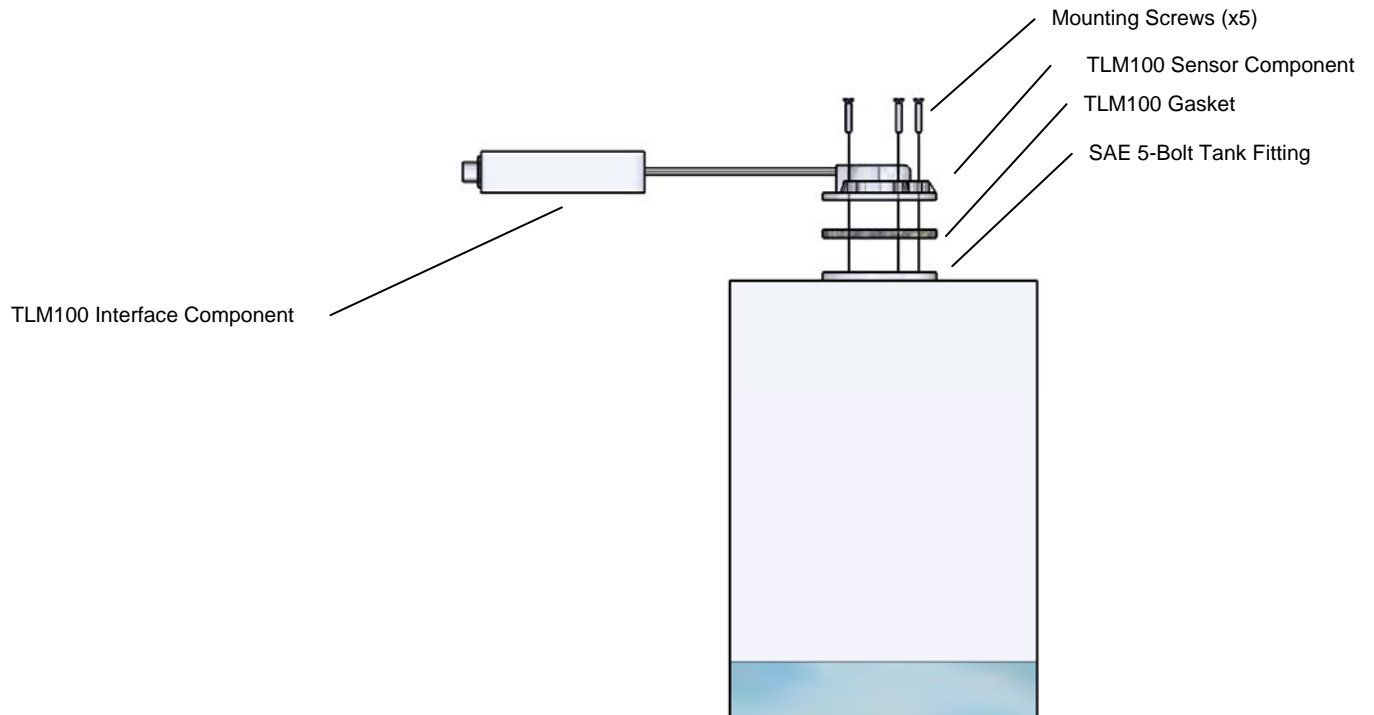

**Figure 1 – TLM100 Mounting – SAE 5-Hole Bolt Pattern**

### 2.3.3.2 Installation on a Tank with a SAE J1810 5-Bolt Fitting and Focus Tube

If a focus tube is used for a tank with a SAE J1810 5-bolt fitting, determine the depth of the tank at the location of the tank sensor mounting hole and use a saw with a metal-cutting blade to trim the focus tube so that it reaches 1" above the tank bottom when mounted. Remove any burrs from the end of the focus tube after trimming.

Next, place the gasket included with the focus tube over the focus tube (between the focus tube flange and the tank mounting flange), and then drop the focus tube into the hole so that the bolt holes on the focus tube, focus tube gasket, and tank fitting all line up.

Place the gasket included with the TLM100 over the focus tube so that the bolt holes line up, then place the TLM100 sensor component on top of the TLM100 gasket so that the bolt holes line up.

Insert mounting screws into the bolt holes on the TLM100 sensor component, and thread them into the tank fitting (the tank fitting may instead have studs installed, so in this case, install the nuts over the studs), tightening them to a torque of 10-15 ft-lbs (13.6-20.3 N·m).



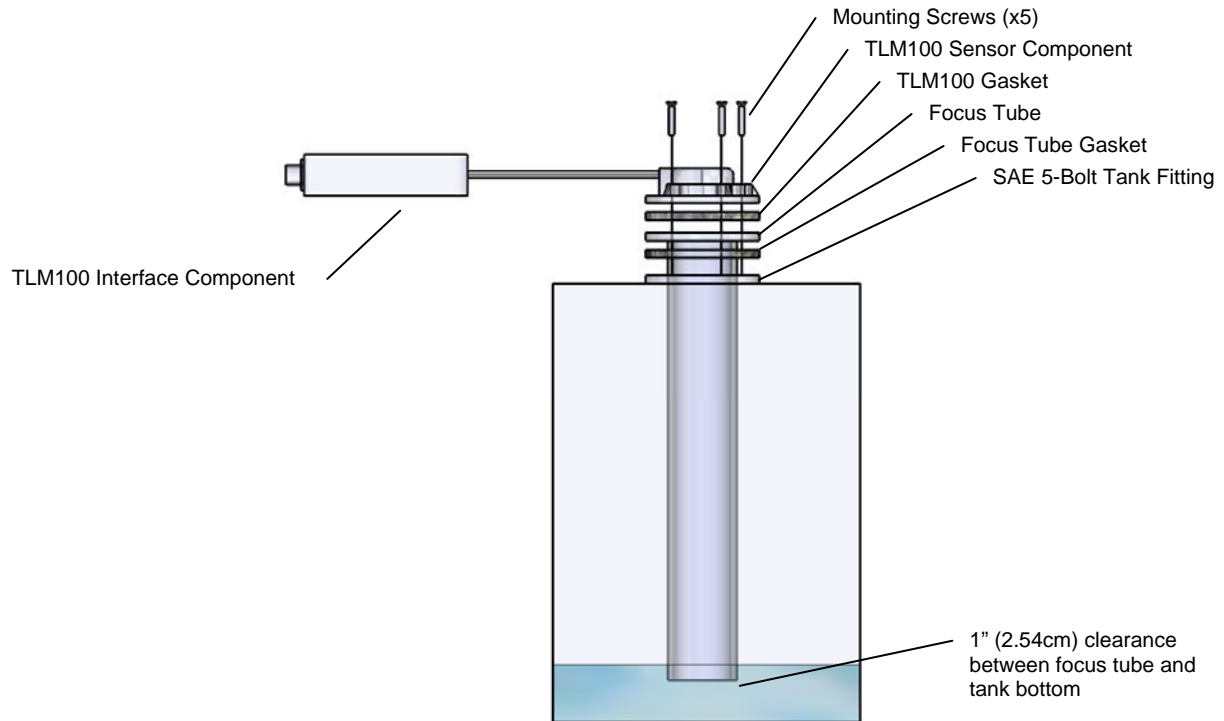

**Figure 2 – Mounting TLM100 to SAE 5-Hole Tank with Focus Tube**

### **2.3.3.3 Installation on a Tank with a SAE J1810 5-Bolt Fitting and Airlock**

Installation of the TLM100 on a tank with a SAE J1810 5-bolt fitting with an airlock is identical to installation with a focus tube, except that the trimming step is eliminated. Please refer to Section 2.3.3.2 for details of the mounting procedure.

### **2.3.3.4 Installation on a Tank with a 1.25" BSP or 1.5" NPT Threaded Tank Fitting**

For a threaded tank sender mounting hole, first thread the adapter into the tank opening and tighten to a torque of 3-5 ft-lbs (4.1-6.8 N·m).

Next, place the TLM100 gasket over the adapter so that the bolt holes on the gasket line up with the bolt holes on the adapter. Place the TLM100 sensor component on top of the adapter so that the bolt holes on the TLM100 sensor component line up with the bolt holes on the adapter.

Place the included mounting screws through the bolt holes on the TLM100 sensor component, and thread them into the adapter, tightening them to a torque of 10-15 ft-lbs (13.6-20.3 N·m).

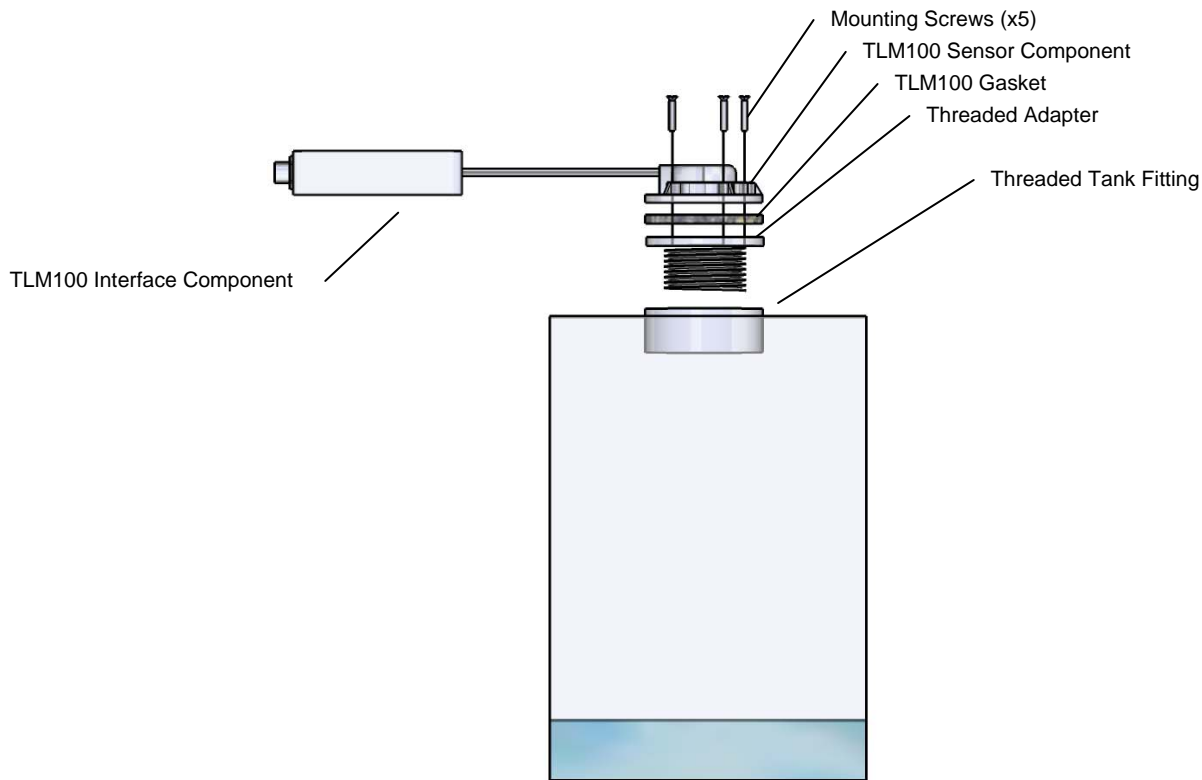

**Figure 3 – TLM100 Mounting With Threaded Adapter**

### **2.3.3.5 Installation on a Tank with a 1.25”BSP or 1.5”NPT Threaded Tank Fitting and Focus Tube**

If a focus tube is used for a tank with a SAE J1810 5-bolt fitting, determine the depth of the tank at the location of the tank sensor mounting hole and use a saw with a metal-cutting blade to trim the focus tube so that it reaches 1” above the tank bottom when mounted. Remove any burrs from the end of the focus tube after trimming.

For a threaded tank sender mounting hole, first thread the adapter into the tank opening and tighten to a torque of 3-5 ft-lbs (4.1-6.8 N·m).

Next, place the TLM100 gasket over the adapter so that the bolt holes on the gasket line up with the bolt holes on the adapter. Place the TLM100 sensor component on top of the adapter so that the bolt holes on the TLM100 sensor component line up with the bolt holes on the adapter.

Place the included mounting screws through the bolt holes on the TLM100 sensor component, and thread them into the adapter, tightening them to a torque of 10-15 ft-lbs (13.6-20.3 N·m).

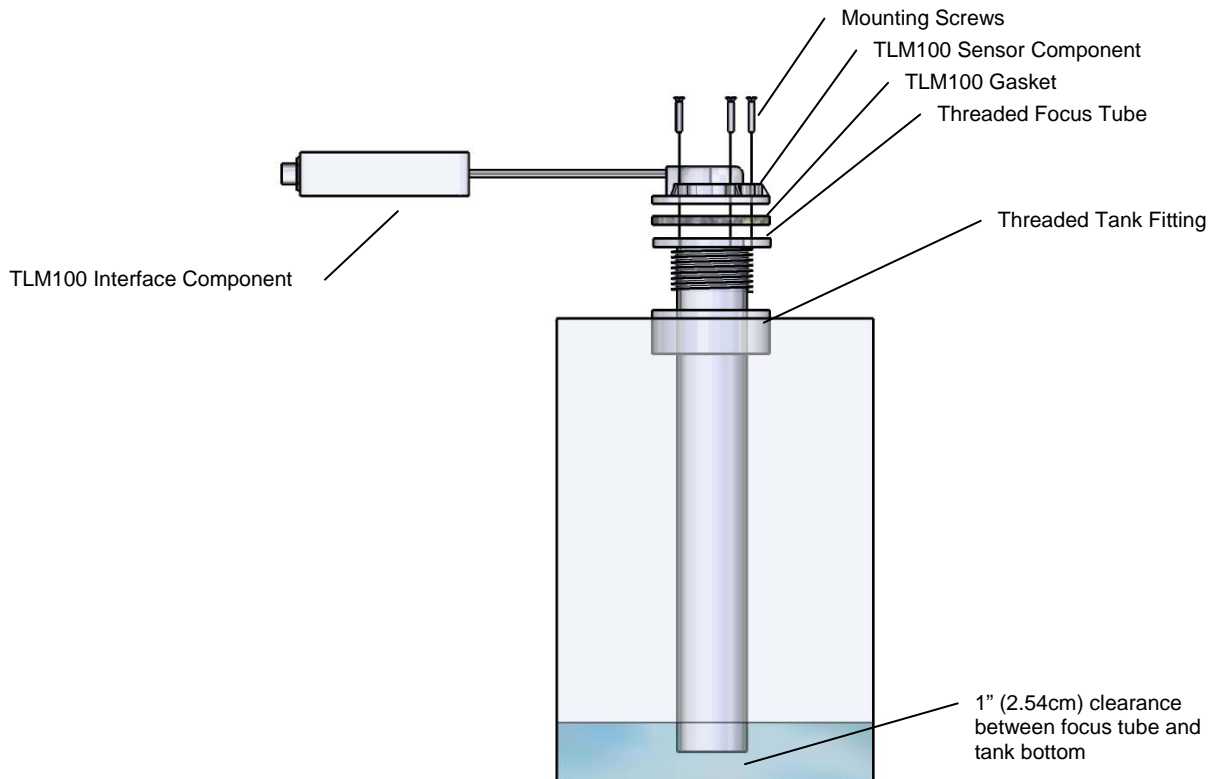

**Figure 4 – Mounting TLM100 with Focus Tube on Threaded Tank Fitting**

### 2.3.3.6 Installation on a Tank with a 1.25" BSP or 1.5" NPT Threaded Tank Fitting and Airlock

Installation of the TLM100 on a tank with a 1.25" BSP or 1.5" NPT threaded tank fitting with an airlock is identical to installation with a focus tube, except that the trimming step is eliminated. Please refer to Section 2.3.3.5 for details of the mounting procedure.

### 2.3.4 Mounting the TLM100 Interface Component

The actual mounting of the TLM100 interface component is not critical and the unit can be mounted in any orientation. The TLM100, NMEA 2000® connector, and cable are all waterproof (rated IP67 – protected against temporary immersion in water) so you can mount the unit virtually anywhere. Once you have located a suitable mounting location, you can secure the TLM100 interface component by placing wire ties with screw eyes on the attached cables next to the TLM100 interface component.

## 2.4 Connecting the TLM100

There is one connection point (see Figure 5) for the TLM100: the NMEA 2000<sup>®</sup> connection. Please refer to Section 2.4.1 for making NMEA 2000<sup>®</sup> connection.



Figure 5 – TLM100 Connections

### 2.4.1 Connecting to NMEA 2000<sup>®</sup> Interface

The Maretron TLM100 provides a connection to an NMEA 2000<sup>®</sup> interface through a five pin male connector (see Figure 6). You connect the TLM100 to an NMEA 2000<sup>®</sup> network using a Maretron NMEA 2000<sup>®</sup> cable (or an NMEA 2000<sup>®</sup> compatible cable) by connecting the female end of the cable to the TLM100 (note the key on the male connector and keyway on the female connector). Be sure the cable is connected securely and that the collar on the cable connector is tightened firmly. Connect the other end of the cable (male) to the NMEA 2000<sup>®</sup> network in the same manner. The TLM100 is designed such that you can plug or unplug it from an NMEA 2000<sup>®</sup> network while the power to the network is connected or disconnected. Please follow recommended practices for installing NMEA 2000<sup>®</sup> network products.

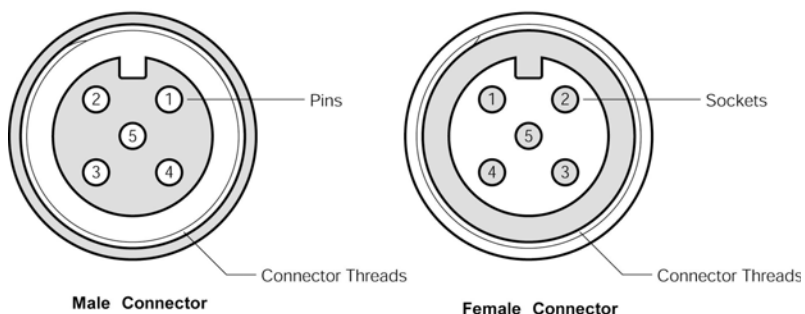

- Pin 1: Shield
- Pin 2: NET-S, (power supply positive, +V)
- Pin 3: NET-C, (power supply common, -V)
- Pin 4: NET-H, (CAN-H)
- Pin 5: NET-L, (CAN-L)

**Figure 6 – NMEA 2000® Connector Face Views**

## 3 Configuring the TLM100

The TLM100 has several configurable parameters, which are shown below including the default values. If you are not using the default values, then you will need to refer to the corresponding section for configuring the TLM100 appropriately.

1. Tank Type – Default is Fuel (Section 3.1)
2. Tank Number – Default is Tank 0 (Section 3.2)
3. Tank Capacity – Default is No Tank Capacity Transmitted (Section 3.3)
4. Tank Depth or Custom Calibration – Default is a 40" (1.02m) deep tank with rectangular cross-section (Section 3.4.1)

### 3.1 Configuring Tank Type

As shipped from the factory, the TLM100 transmits the tank type as "Fuel". You can reconfigure the TLM100 for any of these tank types:

1. Fuel
2. Fresh Water
3. Waste Water
4. Live Well
5. Oil
6. Black Water

You configure or program a TLM100 tank type using a display product such as the Maretron DSM250. Refer to the *DSM250 User's Manual* for configuring the TLM100 as the manual provides detailed instruction on configuration procedures.

### 3.2 Configuring Tank Number

As shipped from the factory, the TLM100 transmits the Tank Number as "0". The TLM100 supports up to sixteen tanks (0 through 15) for a given type of tank, which means you can monitor up to 16 separate fuel tanks or 16 separate fresh water tanks. The TLM100 is configured or programmed by choosing a TLM100 tank number using a display product such as the Maretron DSM250. Refer to the *DSM250 User's Manual* for configuring the TLM100 as the manual provides detailed instruction on configuration procedures.

### 3.3 Configuring Tank Capacity

In addition to indicating the fluid level within a tank, the TLM100 also has the ability to be configured or programmed with the attached tank's capacity. This way, you will be able to view the tank's capacity as well as the amount of fuel remaining anywhere on the vessel where there is an NMEA 2000® compatible display. It is not required, but you can enter the TLM100 tank capacity using a display product such as the Maretron DSM250. Refer to the *DSM250 User's Manual* for configuring the TLM100 as the manual provides detailed instruction on configuration procedures.

## 3.4 Tank Depth or Custom Calibration

The TLM100 can be easily programmed for use with tanks of rectangular cross-section (see Section 3.4.1). For non-rectangular tank shapes, you can perform custom calibration so that the TLM100 accurately reflects fluid levels (see Section 3.4.2).

### 3.4.1 Tank Depth Programming

The TLM100 can be used with tanks that have rectangular cross sections. The TLM100 comes from the factory programmed for a 40" (1.02m) deep tank. In order to obtain correct level readings on a tank having a rectangular cross section but shallower than 40", you must program the TLM100 with the actual depth of the tank using a display product such as the Maretron DSM250. Refer to the *DSM250 User's Manual* for configuring the TLM100 as the manual provides detailed instruction on configuration procedures.

### 3.4.2 Custom Calibration

For accurate tank level readings, the TLM100 must be custom calibrated if the tank shape is irregular or non-rectangular.

You can calibrate the TLM100 using a display product such as the Maretron DSM250. Refer to the user's manual of the particular product that will be used for configuring the TLM100 as these manuals provide detailed instruction on configuration procedures.

## 4 Maintenance

Regular maintenance is not required; however, an occasional inspection will ensure continued proper operation of the Maretron TLM100. Perform the following tasks periodically:

- Ensure that the unit is mounted securely and cannot be moved relative to the mounting surface. If the unit is loose, tighten the screws holding the cable ties.
- Check the security of the cable connected to the NMEA 2000<sup>®</sup> interface and tighten if necessary.

## 5 Troubleshooting

If you notice unexpected operation of the Maretron TLM100, follow the troubleshooting procedures in this section to remedy simple problems.

Symptom	Troubleshooting Procedure
No tank level output	<ol style="list-style-type: none"><li>1. If operating in the <i>NMEA 2000<sup>®</sup> Mode</i>, check the connection to the NMEA 2000<sup>®</sup> interface (see Section 2.4.1) and tighten if necessary.</li><li>2. Ensure that power is supplied to the NMEA 2000<sup>®</sup> network. Proper network power can be checked by measuring the voltage at an open tee between NET-S and NET-C. The voltage should be between 9 and 16 volts.</li><li>3. Ensure that both trunk line terminators are in place. Proper network termination can be checked by removing network power and</li></ol>

	<p>measuring the resistance at an open tee between NET-L and NET-H signals. The resistance should read approximately 60 ohms (two 120 ohm terminators in parallel equals 60 ohms).</p> <p>4. Removed the TLM100 sensor component from the tank opening and ensure that the surface of the ultrasonic sensor is not fouled.</p>
Inaccurate tank level output	<p>1. If operating with a rectangular tank, ensure that the tank depth is programmed properly (see Section 3.4.1).</p> <p>2. If using custom calibration, re-calibrate the TLM100 (see Section 3.4.2).</p>

**Figure 7 – Troubleshooting Guide**

If these steps do not solve your problem, please contact Maretron Technical Support (refer to Section 7 for contact information).

## 6 Technical Specifications

### Specifications

Parameter	Value	Comment
Accuracy	+/-2%	
Resolution	+/-1%	
Number of Tank Types	16	Fuel, Fresh Water, Waste Water, Live Well, Oil, etc.
Number of Tanks per Tank Type	16	16 Tanks per Tank Type Numbered 0-15
Maximum Tank Depth	40" (1.02m)	
Minimum Depth Reading	2" (5.08cm)	Sensor Deadband
Support for Irregularly Shaped Tanks	Yes	Can be Calibrated for any Shape Tank
Programmable Tank Capacity	Yes	Allows Displays to Calculate Amount Remaining
Maximum Tank Angle	6°	Without focus tube
	15°	With focus tube

### Certifications

Parameter	Comment
NMEA 2000	Level B+
Maritime Navigation and Radiocommunication Equipment & Systems	Tested to IEC 60945
FCC and CE Mark	Electromagnetic Compatibility

### NMEA 2000® Parameter Group Numbers (PGNs) - See Appendix A for Details

Description	PGN #	PGN Name	Default Rate
Periodic Data PGNs	127505	Fluid Level	0.4 Times/Second
Response to Requested PGNs	126464	PGN List (Transmit and Receive)	N/A
	126996	Product Information	N/A
	126998	Configuration Information	N/A
Protocol PGNs	059392	ISO Acknowledge	N/A
	059904	ISO Request	N/A
	060928	ISO Address Claim	N/A
	065240	ISO Address Command	N/A
	126208	NMEA	N/A

# TLM100 User's Manual

---

## Electrical

Parameter	Value	Comment
Operating Voltage	9 to 16 Volts	DC Voltage
Power Consumption	<100mA	Average Current Drain
Load Equivalence Number (LEN)	2	NMEA 2000 <sup>®</sup> Spec. (1LEN = 50mA)
Reverse Battery Protection	Yes	Indefinitely
Load Dump Protection	Yes	Energy Rated per SAE J1113

## Mechanical

Parameter	Value	Comment
Size	3.9" x 1.2" x 1.0" (99mm x 30.5mm x 25.4mm)	Interface Component
	2.7" dia. X 0.9" (68.6mm dia. x 22.9mm)	Sensor Component
	8.5" (215.9mm)	Interconnecting Cable
Weight	12 oz. (340g)	
Mounting	SAE J1810 5-hole bolt pattern	Can mount to 1.25" BSP or 1.5" NPT using available adapters

## Environmental

Parameter	Value
IEC 60945 Classification	Exposed
Degree of Protection	IP67
Operating Temperature	-25°C to 55°C
Storage Temperature	-40°C to 70°C
Relative Humidity	93%RH @40° per IEC60945-8.2
Vibration	2-13.2Hz @ ±1mm, 13.2-100Hz @ 7m/s <sup>2</sup> per IEC 60945-8.7
Rain and Spray	12.5mm Nozzle @ 100liters/min from 3m for 30min per IEC 60945-8.8
Solar Radiation	Ultraviolet B, A, Visible, and Infrared per IEC 60945-8.10
Corrosion (Salt Mist)	4 times 7days @ 40°C, 95%RH after 2 hour Salt Spray Per IEC 60945-8.12
Electromagnet Emission	Conducted and Radiated Emission per IEC 60945-9
Electromagnetic Immunity	Conducted, Radiated, Supply, and ESD per IEC 60945-10
Safety Precautions	Dangerous Voltage, Electromagnetic Radio Frequency per IEC 60945-12

## 7 Technical Support

If you require technical support for Maretron products, you can reach us in one of the following ways:

Telephone: 1-866-550-9100  
Fax: 1-602-861-1777  
E-mail: [support@maretron.com](mailto:support@maretron.com)  
World Wide Web: <http://www.maretron.com>  
Mail: Maretron, LLP  
Attn: Technical Support  
9014 N. 23<sup>rd</sup> Ave Suite 10  
Phoenix, AZ 85021 USA



## 8 Maretron (2 Year) Limited Warranty

Maretron warrants the TLM100 to be free from defects in materials and workmanship for **two (2) years** from the date of original purchase. If within the applicable period any such products shall be proved to Maretron's satisfaction to fail to meet the above limited warranty, such products shall be repaired or replaced at Maretron's option. Purchaser's exclusive remedy and Maretron's sole obligation hereunder, provided product is returned pursuant to the return requirements below, shall be limited to the repair or replacement, at Maretron's option, of any product not meeting the above limited warranty and which is returned to Maretron; or if Maretron is unable to deliver a replacement that is free from defects in materials or workmanship, Purchaser's payment for such product will be refunded. Maretron assumes no liability whatsoever for expenses of removing any defective product or part or for installing the repaired product or part or a replacement therefore or for any loss or damage to equipment in connection with which Maretron's products or parts shall be used. With respect to products not manufactured by Maretron, Maretron's warranty obligation shall in all respects conform to and be limited to the warranty actually extended to Maretron by its supplier. The foregoing warranties shall not apply with respect to products subjected to negligence, misuse, misapplication, accident, damages by circumstances beyond Maretron's control, to improper installation, operation, maintenance, or storage, or to other than normal use or service.

THE FOREGOING WARRANTIES ARE EXPRESSLY IN LIEU OF AND EXCLUDES ALL OTHER EXPRESS OR IMPLIED WARRANTIES, INCLUDING BUT NOT LIMITED TO THE IMPLIED WARRANTIES OF MERCHANTABILITY AND OF FITNESS FOR A PARTICULAR PURPOSE.

Statements made by any person, including representatives of Maretron, which are inconsistent or in conflict with the terms of this Limited Warranty, shall not be binding upon Maretron unless reduced to writing and approved by an officer of Maretron.

IN NO CASE WILL MARETRON BE LIABLE FOR INCIDENTAL OR CONSEQUENTIAL DAMAGES, DAMAGES FOR LOSS OF USE, LOSS OF ANTICIPATED PROFITS OR SAVINGS, OR ANY OTHER LOSS INCURRED BECAUSE OF INTERRUPTION OF SERVICE. IN NO EVENT SHALL MARETRON'S AGGREGATE LIABILITY EXCEED THE PURCHASE PRICE OF THE PRODUCT(S) INVOLVED. MARETRON SHALL NOT BE SUBJECT TO ANY OTHER OBLIGATIONS OR LIABILITIES, WHETHER ARISING OUT OF BREACH OF CONTRACT OR WARRANTY, TORT (INCLUDING NEGLIGENCE), OR OTHER THEORIES OF LAW WITH RESPECT TO PRODUCTS SOLD OR SERVICES RENDERED BY MARETRON, OR ANY UNDERTAKINGS, ACTS OR OMISSIONS RELATING THERETO.

Maretron does not warrant that the functions contained in any software programs or products will meet purchaser's requirements or that the operation of the software programs or products will be uninterrupted or error free. Purchaser assumes responsibility for the selection of the software programs or products to achieve the intended results, and for the installation, use and results obtained from said programs or products. No specifications, samples, descriptions, or illustrations provided Maretron to Purchaser, whether directly, in trade literature, brochures or other documentation shall be construed as warranties of any kind, and any failure to conform with such specifications, samples, descriptions, or illustrations shall not constitute any breach of Maretron's limited warranty.

### **Warranty Return Procedure:**

To apply for warranty claims, contact Maretron or one of its dealers to describe the problem and determine the appropriate course of action. If a return is necessary, place the product in its original packaging together with proof of purchase and send to an Authorized Maretron Service Location. You are responsible for all shipping and insurance charges. Maretron will return the replaced or repaired product with all shipping and handling prepaid except for requests requiring expedited shipping (i.e. overnight shipments). Failure to follow this warranty return procedure could result in the product's warranty becoming null and void.

Maretron reserves the right to modify or replace, at its sole discretion, without prior notification, the warranty listed above. To obtain a copy of the then current warranty policy, please go to the following web page:

<http://www.maretron.com/company/warranty.php>

This page intentionally left blank.

## Appendix A – NMEA 2000® Interfacing

### TLM100 NMEA 2000® Periodic Data Transmitted PGNs

#### ***PGN 127505 – Fluid Level***

The TLM100 uses this PGN to indicate the attached tank's fluid instance, fluid type, fluid level, and tank capacity.

- Field 1: Fluid Instance – This field is used to identify the tank number and ranges between 0 and 15. There can be up to 16 tanks of a given type as defined by the Fluid Type field. This field is programmable through the NMEA command PGN. The TLM100 ships from the factory with a default value of zero.
- 2: Fluid Type – This field identifies the type of fluid contained within the tank. Currently the defined fluid types are fuel, fresh water, wastewater, live well, oil, and black water. The TLM100 ships from the factory with a default value of 0x0 indicating "Fuel".
- 3: Fluid Level – This field is used to indicate the current fluid level in percentage. The value transmitted in this field depends on the sender resistance value..
- 4: Tank Capacity – This field is used to indicate the tank capacity. The TLM100 ships from the factory with a default value of 0xFFFFFFFF indicating "Data Not Available".
- 5: Reserved – This field is reserved by NMEA; therefore, the TLM100 sets all bits to a logic 1.