



AX2010

User Manual

[AX2010-UM-102-EN]

Rev 1.0.2
January 2012

AppoTech Limited

Add: Unit 705-707, 7/F, IC Development Ctr, No. 6, Science Park West Ave. Hong Kong Science Park, Shatin, N.T. HK
Tel: (852) 2607 4090 Fax: (852) 2607 4096 www.appotech.com

AX2010 8-bit CMOS Micro Controller



High Performance 8-bit MCU

- DC-48MHz operation
- Compatible with 8051
- 104ns internal interrupt response at 48 MIPS
- All instructions are single-cycled except branching instructions
- Two data pointers for indirect addressing

Program Memory and Data Memory

- 60K Bytes Mask ROM program memory
- 32K Bytes OTP program memory
- 34K Bytes internal SRAM used for program and/or data memory

Flexible I/O

- 28 GPIO pins
- All GPIO pins are internally pull-up selectable
- CMOS/TTL-level Schmitt triggered inputs

Digital Peripheral Features

- Two multi-function 8-bit timers, support Capture and PWM mode
- Two multi-function 16-bit timers, support Capture and PWM mode
- Watchdog Timer with on-chip RC oscillator
- One high-speed full-duplex UART
- MP3 decoder
- WMA decoder
- SPI

- One EMI controller, use for external memory access
- Full-speed USB 2.0 OTG controller

Analog Peripheral Features

- One 4~24MHz Crystal Oscillator
- Full-speed USB 2.0 OTG PHY
- PLL
- DAC
- ADC
- Power-on reset
- Two Low Drop-Out regulators: 5V to 1.8V, 5V to 3.3V
- RC Oscillator

Programming and Debugging Support

- In-System Programming (ISP) support
- In-System Debugging (ISD) support

Power Supply

- LDOVDD is 3.2V to 5.5V
- VDDIO is 3.0V to 3.6V
- VDDCORE is 1.6V to 2.0V

Packages

- LQFP48
- DIE form

Temperature

- Operating temperature: -40°C to +85°C
- Storage temperature: -65°C to +150°C

AppoTech Limited

Address :Unit 705-707, 7/F, IC Development Centre,
No.6, Science Park West Ave.,
Hong Kong Science Park,
Shatin, N.T., Hong Kong

Telephone :(852) 2607 4090

Fax :(852) 2607 4096

www.appotech.com

Table of Contents

1 PIN DEFINITIONS	4
1.1 Part Numbering.....	4
1.2 Packages.....	4
1.3 Pin Assignment.....	4
2 MEMORY ORGANIZATION	5
2.1 Special Function Registers.....	5
3 INTERRUPT	6
3.1 Interrupt Sources and Vectors.....	6
3.2 Interrupt Priority.....	6
3.3 Interrupt Latency.....	8
4 FLEXIBLE INPUTS/OUTPUTS (I/O)	9
4.1 Data Direction Configuration.....	9
4.2 Port Data Configuration.....	9
4.3 Pull-up Configuration.....	9
4.4 Pull-down Configuration.....	10
4.5 Digital Input Enable Configuration.....	10
4.6 Wakeup.....	10
4.6.1 Wakeup through External Port0.....	10
4.6.2 Wakeup Registers.....	11
5 Timers and oscillator	12
5.1 Watchdog Timer with On-chip 32KHz RC oscillator.....	12
6 Universal Asynchronous Receiver Transmitter (UART)	13
6.1 Overview.....	13
6.2 Special Function Registers.....	13
7 Characteristics	15
7.1 I/O DC Characteristics.....	15
7.2 MCLR DC Characteristics.....	16
7.3 DAC characteristics.....	16
7.4 Reset Characteristics.....	17
8 Ordering Code	18
Appendix I Revision History	19

1 PIN DEFINITIONS

1.1 Part Numbering

AX2010

1.2 Packages

LQFP48

1.3 Pin Assignment

Figure 1-1: Pin assignment for LQFP48 package

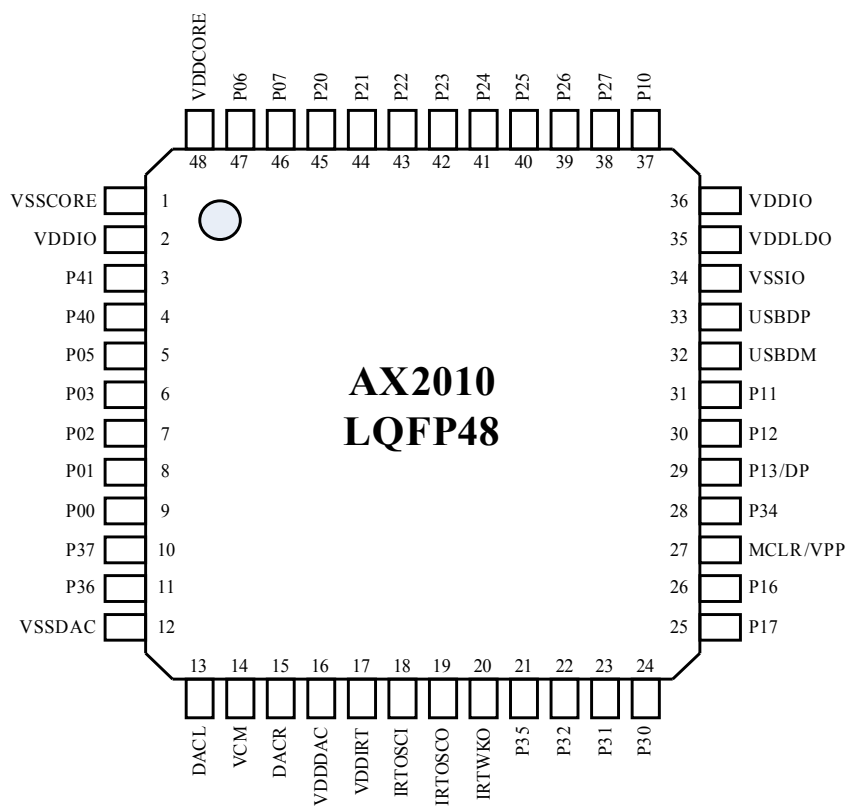

2 MEMORY ORGANIZATION

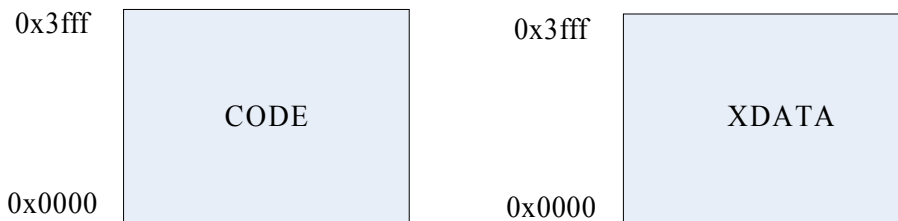

2.1 Special Function Registers

The Special Function Registers (SFR) used by the CPU and Peripheral Modules for controlling the desired operation. The Special Function Registers can be classified into two sets: core and peripheral. Core SFR will be described in this section. Peripheral SFR will be described in related peripherals.

Register 2-1: PSW - Processor Status Word

PSW	Address	7	6	5	4	3	2	1	0	Default Value
Processor Status Word	0xD0	CY	AC	F1	RS1	RS0	OV	SBS	P	0000 0000
BANK 0		R/W	R/W	R/W	R/W	R/W	R/W	R/W	R/W	

CY: Carry Flag
AC: Auxiliary carry flag
F1: General purpose flag available for user
RS1, RS0: Register bank select
 00: bank0
 01: bank1
 10: bank2
 11: bank3
OV: Overflow flag
SBS: SFR bank select
 0: Select SFR bank0
 1: Select SFR bank1
P: Odd parity check of ACC
 0: There are even number of '1' bits in ACC
 1: There are odd number of '1' bits in ACC

3 INTERRUPT

3.1 Interrupt Sources and Vectors

All interrupts, with the exception of the ISD, are controlled by a series combination of individual enable bits and a global enable (EA) in the interrupt-enable register (IEN0.7). Setting EA to logic 1 allows individual interrupts to be enabled. Setting EA to logic 0 disables all interrupts regardless of the individual interrupt-enable settings. The interrupt enables and priorities are functionally identical to those of the 80C52, except that the AX2010 supports 3 levels of interrupt priorities instead of the original 2.

3.2 Interrupt Priority

There are 3 levels of interrupt priority: Level 2 to 0. The highest interrupt priority is level 2, which is reserved for the ISD interrupts. All other interrupts have individual priority bits in the interrupt priority registers to allow each interrupt to be assigned a priority level from 1 to 0. All interrupts also have a natural hierarchy. In this manner, when a set of interrupts has been assigned the same priority, a second hierarchy determines which interrupt is allowed to take precedence. The natural hierarchy is determined by analysing potential interrupts in a sequential manner with the order listed in Table 3-1.

The processor indicates that an interrupt condition occurred by setting the respective flag bit. This bit is set regardless of whether the interrupt is enabled or disabled.

Table 3-1: Interrupt Summary

Interrupt Sources	Interrupt Vector	Interrupt Number	Natural Order	Interrupt Flag	Interrupt Enable Bit	Priority Control Bit
Timer 0	0x000B / 0x400B	1	2	TMR0CON.7	IE0.1	IP0.1
Timer 1	0x0013 / 0x4013	2	3	TMR1CON.7 TMR1CON.6	IE0.2	IP0.2
Timer 2	0x001B / 0x401B	3	4	TMR2CON.7 TMR2CON.6	IE0.3	IP0.3
Timer 3	0x0023 / 0x4023	4	5	TMR3CON.7	IE0.4	IP0.4
PORT	0x0063 / 0x4063	12	13	WKPND	IE1.5	IP1.5
LVD	0x0073 / 0x4073	14	15	LVDCON.7	IE1.7	IP1.7
WDT	0x0073 / 0x4073	14	15	WDTCON.7	IE1.7	IP1.7
RTCC	0x0073 / 0x4073	14	15	RTCON.7	IE1.7	IP1.7
UART	0x0073 / 0x4073	14	15	UTSTA.5 UTSTA.4	IE1.7	IP1.7
IRTCC	0x0073/0x4073	14	15	IRTCON.3 IRTCON.5	IE1.7	IP1.7

Register 3-1: IEN0 - Interrupt Enable 0 Register

IEN0	Address	7	6	5	4	3	2	1	0	Default Value
Interrupt Enable 0 Register	0xA8	EA	-	-	T3IE	T2IE	T1IE	TOIE	-	0000 0000
BANK 0		R/W	R/W	R/W	R/W	R/W	R/W	R/W	R/W	
EA: Global Interrupt Enable Bit 0: Disable 1: Enable T3IE: Timer3 Interrupt Enable Bit 0: Disable										

1: Enable
T2IE: Timer2 Interrupt Enable Bit
 0: Disable
 1: Enable
T1IE: Timer1 Interrupt Enable Bit
 0: Disable
 1: Enable
TOIE: Timer0 Interrupt Enable Bit
 0: Disable
 1: Enable

Register 3-2: IEN1 - Interrupt Enable 1 Register

IEN1	Address	7	6	5	4	3	2	1	0	Default Value
Interrupt Enable 1 Register	0xA9	UIE	-	PORTIE	-	-	-	-	-	0000 0000
BANK 0		R/W	-	R/W	R/W	R/W	R/W	R/W	R/W	

UIE: LVD / UART/WDT Interrupt Enable Bit
 0: Disable
 1: Enable
PORTIE: Port Wakeup Interrupt Enable Bit
 0: Disable
 1: Enable

Register 3-3: IP0 - Interrupt Priority 0 Register

IP0	Address	7	6	5	4	3	2	1	0	Default Value
Interrupt Priority 0 Register	0xB8	-	-	-	T3IP	T2IP	T1IP	T0IP	-	- 000 0000
BANK 0		-	R/W	R/W	R/W	R/W	R/W	R/W	R/W	

T3IP: Timer3 Interrupt Priority Select
 0: Low 1: High
T2IP: Timer2 Interrupt Priority Select
 0: Low 1: High
T1IP: Timer1 Interrupt Priority Select
 0: Low 1: High
T0IP: Timer0 Interrupt Priority Select
 0: Low 1: High

Register 3-4: IP1 - Interrupt Priority 1 Register

IP1	Address	7	6	5	4	3	2	1	0	Default Value
Interrupt Priority 1 Register	0xB9	UIP	-	POR TIP	-	-	-	-	-	0000 0000
BANK 0		R/W	R/W	R/W	R/W	R/W	R/W	R/W	R/W	

UIP: LVD / UART/WDT Interrupt Priority Select
 0: Low 1: High
POR TIP: Port Wakeup Interrupt Priority Select
 0: Low 1: High

3.3 Interrupt Latency

Interrupt response time depends on the state of the CPU when the interrupt occurs. Pending interrupts are sampled and priority decoded each system clock cycle. Therefore, the fastest possible response time is 4 system clock cycles: 1 clock cycle to detect the interrupt and 3 clock cycles to complete the LCALL to the ISR. Additional clock cycles will be required if the CPU is executing branch instructions (e.g.: ACALL, LJMP, JZ...). If an interrupt is pending when a RETI is executed, a single instruction is executed before an LCALL is made to service the pending interrupt. If the CPU is executing an ISR for an interrupt with equal or higher priority, the new interrupt will not be serviced until the current ISR completes, including the RETI and following instruction.

4 FLEXIBLE INPUTS/OUTPUTS (I/O)

AX2010 provides four ports (Port 0/1/2/3) for user to develop applications. Inputs are all Schmitt triggered with about 400-500mV hysteresis level to filter input voltage fluctuations. Each port pin can be independently set as input or output. Most of the port pins are built-in slew-rate controlled to reduce output bouncing noise. There is also an internally 10KΩ pull-up resistor selectable for each input port pin.

4.1 Data Direction Configuration

There are four port data direction registers: P0DIR, P1DIR, P2DIR, P3DIR. All port pins are defined as “output” when it is set as “0” and as “input” when it is set as “1”. Table 4-1 illustrates the configuration.

Table 4-1: PxDIR registers setting

Register	Address	Set bit “x” of PxDIR as “1”	Clear bit “x” of PxDIR as “0”	Initial value
P0DIR	BAh	Inputs	Outputs	FFh
P1DIR	BBh	Inputs	Outputs	FFh
P2DIR	BCh	Inputs	Outputs	FFh
P3DIR	BDh	Inputs	Outputs	FFh

4.2 Port Data Configuration

There are four port data registers: P0, P1, P2, P3. The port data value is stored as “0” when Px register is set to “0” and as “1” when Px register is set to “1”. Table 4-2 illustrates the configuration.

Table 4-2: Px registers setting

Register	Address	Set bit x of Px as “1”	Clear bit x of Px as “0”	Initial value
P0	80h	Stored “1”	Stored “0”	xx
P1	90h	Stored “1”	Stored “0”	xx
P2	A0h	Stored “1”	Stored “0”	xx
P3	B0h	Stored “1”	Stored “0”	xx

4.3 Pull-up Configuration

There are four data pull-up registers: P0UP, P1UP, P2UP, P3UP. The port pin will be pull-up disabled when PxUP register is set to “0” or the pin is set as output, and pull-up enabled when it is set to “1” and the pin is set as input. Table 4-3 shows the register setting.

Table 4-3: PxUP register setting

Register	Address	Set as “1”	Clear as “0”	Initial value
P0UP(BANK 1)	BAh	Enable pull-up	Disable pull-up	00h
P1UP(BANK 1)	BBh	Enable pull-up	Disable pull-up	08h
P2UP(BANK 1)	BCh	Enable pull-up	Disable pull-up	00h
P3UP(BANK 1)	BDh	Enable pull-up	Disable pull-up	00h

4.4 Pull-down Configuration

There are 2 data pull-down bit: SPMODE[0] for pin P1.7 and SPMODE[1] for pin P3.7 and P0.6. The port pin will be pull-down disabled when SPMODE[0] or SPMODE[1] is set to “0” and pull-down enabled when it is set to “1”. Table 4-4 shows the register setting.

Table 4-4: SPMODE register setting

Bit	Address	Set as “1”	Clear as “0”	Initial value
SPMODE.0	AEh	Enable pull-down	Disable pull-down	1
SPMODE.1	AEh	Enable pull-down	Disable pull-down	1

4.5 Digital Input Enable Configuration

There is 1 digital input enable register: PIE. There are several I/O MUXed with analog module. I/O digital input and output must be disabled when Analog Module is enabled.

Register 4-1: PIE – Port Digital Input Enable

PIE	Address	7	6	5	4	3	2	1	0	Default Value
Port Input Enable	0x9A	PIE7	PIE6			PIE3	PIE2	PIE1	PIE0	11 - - 1111
BANK 0		R/W	R/W			R/W	R/W	R/W	R/W	

PIE7: P35 and P37 Digital Input Enable Bit (For AMUX)
 0 = P35 and P37 Input Disabled
 1 = P35 and P37 Input Enabled
PIE6: P34 and P36 Digital Input Enable Bit (For AMUX)
 0 = P34 and P36 Input Disabled
 1 = P34 and P36 Input Enabled
PIE3: P03 Digital Input Enable Bit (For ADC3)
 0 = P03 Input Disabled
 1 = P03 Input Enabled
PIE2: P02 Digital Input Enable Bit (For ADC2)
 0 = P02 Input Disabled
 1 = P02 Input Enabled
PIE1: P01 Digital Input Enable Bit (For ADC1)
 0 = P01 Input Disabled
 1 = P01 Input Enabled
PIE0: P00 Digital Input Enable Bit (For ADC0 or LVD external input)
 0 = P00 Input Disabled
 1 = P00 Input Enabled

4.6 Wakeup

4.6.1 Wakeup through External Port0

Wakeup is one way of causing the device to exit the power down mode. AX2010 supports Port Wakeup. The PWKEN registers (Wakeup Enable Register) allow P0.4, P0.5, P0.6 and P0.7 to cause wakeup.

Clearing bit0-3 in the PWKEN register enables wakeup on corresponding pin of P0.4, P0.5, P0.6 and P0.7. The trigger condition on the selected pin can be either rising edge or falling edge. The WKED register (Wakeup Edge Select) selects the desired transition edge. Setting a bit in WKED register selects the falling edge of the corresponding P0.4, P0.5, P0.6 and P0.7 pin. Resetting the bit selects the rising edge. The PWKEN registers are set to 0Fh upon reset.

Once a valid transition occurs on the selected pin, the WKPND(PWKEN.7~PWKEN.4) register (Wakeup Pending Register) latches the transition in the corresponding bit position. Logic '1' indicates the occurrence of the selected trigger edge on the corresponding Port pins. Upon reset, logic '0' is set to all bits of WKPND.

Note:

1. **Port 0 Wakeup initialization**, To avoid any false signalling to port, the followings would be a recommended procedure for Wakeup initialization:
 - Configure the edge select of Port 0 pins on WKEDG register,
 - Clear the corresponding bits on WKPND Wakeup Pending Register
 - Clear the corresponding bits in the PWKEN registers to enable the wakeup on the corresponding port pins
2. Upon exiting the sleep down mode, the Multi-Input Wakeup logic causes full chip reset.

4.6.2 Wakeup Registers

Register 4-2: PWKEN – Port 0 Wakeup Enable Register

PWKEN	Address	7	6	5	4	3	2	1	0	Default Value
Port 0 Wakeup Enable Register	0x98	WKP ND3	WKP ND2	WKP ND1	WKP ND0	PWK EN3	PWK EN2	PWK EN1	PWK EN0	0000 1111
BANK 0		R/W	R/W	R/W	R/W	R/W	R/W	R/W	R/W	

WKPNDx
 0 = No port0.x wakeup event occurred
 1 = Port0.x wakeup event occurred

PWKENx
 0 = Enable Port0.x Wakeup
 1 = Disable Port0.x Wakeup

Note:

1. Enable Port0.x Wakeup is a condition of Port0.x wakeup events occurred.
2. To enable WKPNDx, set PWKENx to '0'.
3. To clear WKPNDx, write '0' to WKPNDx. WKPNDx will be '0' 2 clocks later after write '0' to WKPNDx.
4. WKPNDx is cleared when PWKENx is '1'.

Register 4-3: PWKEDGE – Port 0 Wake up Event Select

PWKEDGE	Address	7	6	5	4	3	2	1	0	Default Value
Port 0 Wake up Event Select	0x99	-	-	-	-	WKE DG3	WKE DG2	WKE DG1	WKE DG0	---- xxxx
BANK 0						R/W	R/W	R/W	R/W	

WKEDGx: Port Wake up Edge Select
 0 = select rising edge as wake up event
 1 = select falling edge as wake up event

5 Timers and oscillator

5.1 Watchdog Timer with On-chip 32KHz RC oscillator

The Watchdog Timer (WDT) logic consists of a 20bit Watchdog Timer. The Watchdog Timer is clocked by internal RC oscillator running at 32KHz. When device resets, the WDT is disabled and user should enable the WDT if it is needed.

In the default configuration, WDT overflows in 2 ms. The application program needs to write a '1' into WDTCON[5] at least once 2 ms to prevent WDT time out. The lower 3 bits of the WDTCON register control the selection of overflow time period.

WDT Registers

Register 5-1: WDTCON – Watchdog Configure Register

WDTCON	Address	7	6	5	4	3	2	1	0	Default Value
Watchdog Configure Register	0xF7	WDTT O	WDTP D	CLR WDT	WDT EN	RSTE N	WDTPS			0000 0000
BANK 0		R/W	R/W	WO	R/W	R/W	R/W	R/W	R/W	

WDTTO:
0 = Read '0' after clear Watchdog or Power up
1 = Read '1' after Watchdog time out

WDTPD:
0 = read '0' before sleep operation
1 = read '1' after sleep operation

CLRWDT:
Write 1 : Clear WDT counter
Write 0 : No action

WDTEN:
0 = Disables the Watchdog timer
1 = Enables the Watchdog timer

RSTEN:
0 = Disables the Watchdog reset
1 = Enables the Watchdog reset

WDTPS: WDT time out period setting
000 : 2ms
001 : 8ms
010 : 32ms
011: 128ms
100 : 512ms
101: 2048ms
110 : 8192ms
111 : 32768ms

Watchdog Wake up

There are 2 modes for wake up operation: wake up without reset and wake up with reset. It determines by RSTEN bit (WDTCON[3]). When RSTEN sets to 0, the watchdog will generate a non-reset wake up after counter overflows. Only in HOLD Mode, non-reset wake up can wakeup AX2010 and it will continue to execute next instruction. AX2010 cannot be waken up by WDT without reset in SLEEP Mode. When RSTEN sets to 1, the watchdog will generate a reset wakeup after counter overflows. Both in HOLD Mode and SLEEP Mode, watchdog reset can wake up the chip, and then, AX2010 goes back to the initial state.

6 Universal Asynchronous Receiver Transmitter (UART)

6.1 Overview

UART is a serial port capable of asynchronous transmission. The UART can function in full duplex mode. Receive data is buffered in a holding register. This allows the UART to start reception of a second incoming data byte before software has finished reading the previous data byte.

When **U1SRC** = 0

- Receive pin (U1RX) – P0.6
- Transmit pin (U1TX) – P1.6

When **U1SRC** = 1

- Receive pin (U1RX) – P3.7
- Transmit pin (U1TX) – P3.5

6.2 Special Function Registers

Register 6-1: UARTCON – UART Configure Register

UARTCON	Address	7	6	5	4	3	2	1	0	Default Value
UART Configure Register	0xFD	UTSBS	UTTXNB	NBITEN	UTEN	UTTXINV	UTRXINV	TXIE	RXIE	0100 0000
BANK 0		R/W	R/W	R/W	R/W	R/W	R/W	R/W	R/W	

UTSBS: Stop Bit Select
 0 = 1 bit as Stop Bit
 1 = 2 bits as Stop Bit

UTTXNB: The ninth bit data of transmitter buffer. Write the ninth bit into this location that you want to transmit

NBITEN: Nine-BIT mode Enable Bit
 0 = Eight-bit mode
 1 = Nine-bit mode

UTEN: UART Enable Bit
 0 = Disable UART module
 1 = Enable UART module

UTTXINV: Transmit Invert Selection Bit
 0 = Transmitter output without inverted
 1 = Transmitter output inverted

UTRXINV: Receive Invert Selection Bit
 0 = Receiver input without inverted
 1 = Receiver input inverted

TXIE: Transmit Interrupt Enable
 0 = Transmit interrupt disable
 1 = Transmit interrupt enable

RXIE: Receive Interrupt Enable
 0 = Receiver interrupt disable
 1 = Receiver interrupt enable

Register 6-2: UARTSTA – UART Status Register

UARTSTA	Address	7	6	5	4	3	2	1	0	Default Value
UART Status Register	0xFC	UTRX NB	FEF	U1RXIF	U1TXIF	-	-	-	U1SRC	xx01 -- 0
BANK 0		R/W	R/W	R/W	R/W	-	-	-	R/W	

UTRXNB: The ninth bit data of receiver buffer
FEF: Frame Error Flag
 0 = the stop bit is '1' in the last received frame
 1 = the stop bit is '0' in the last received frame
U1RXIF: UART RX Interrupt Flag
 0 = UART receive not done
 1 = UART receive done
U1TXIF: UART TX Interrupt Flag
 0 = UART transmit not done
 1 = UART transmit done
 Writing a data to UTBUF or 0 to **U1TXIF** to clear this flag.
U1SRC: UART Source Select
 0 = UART select
 P0.6 as receive pin
 P1.6 as transmit pin
 1 = UART select
 P3.7 as receive pin
 P3.5 as transmit pin

Register 6-3: UTBAUD – UART Baud Rate Register

Register of UART baud rate generator

Baud rate formula:

$$\text{Baud Rate} = \text{system clock} / [8 (n + 1)]$$

(n is 8-bit Register, range 0 ~ 256)

UARTBAUD	Address	7	6	5	4	3	2	1	0	Default Value
UART Baud Rate Register	0xFE	UARTBAUD								xxxx xxxx
BANK 0		R/W	R/W	R/W	R/W	R/W	R/W	R/W	R/W	

Register 6-4: UARTDATA – UART Data Register

UARTDATA	Address	7	6	5	4	3	2	1	0	Default Value
UART Data Register	0xFF	UARTDATA								xxxx xxxx
BANK 0		R/W	R/W	R/W	R/W	R/W	R/W	R/W	R/W	

Write this location will load the data to transmitter buffer, read this location will read the data from the receiver buffer.

7 Characteristics

7.1 I/O DC Characteristics

Table 7-1: I/O input DC voltage parameters

Symbol	Descriptions	Min	Typ	Max	Units	Conditions
V _{IL}	Low-Level Input Voltage	-	-	30% * VDDIO	V	VDDIO = 3.3V
V _{IH}	High-Level Input Voltage	70% * VDDIO	-	-	V	VDDIO = 3.3V

Low-level input voltage (V_{IL}) is the threshold voltage read as logic “0”. Higher than V_{IL} may not read as “0”. For the difference between devices (or pins), the V_{IL} are different, so all the design should refer to the actual criterion.

High-level input voltage (V_{IH}) is the threshold voltage read as logic “1”. Lower than V_{IH} may not read as “1”. For the difference between devices (or pins), the V_{IH} are different, so all the design should refer to the actual criterion.

7.2 MCLR DC Characteristics

Table 7-2: MCLR input DC voltage parameters

Symbol	Descriptions	Min	Typ	Max	Units	Conditions
V_{MIL}	MCLR Low-Level Input Voltage	-	$0.2 \cdot V_{DDIO}$	-	V	$V_{DDIO} = 3.3V$
V_{MIH}	MCLR High-Level Input Voltage	-	$0.8 \cdot V_{DDIO}$	-	V	$V_{DDIO} = 3.3V$

Table 7-3: MCLR input AC voltage parameters

Symbol	Descriptions	Min	Typ	Max	Units	Conditions
T_{MCLR}	MCLR Low-Level Input width	1	-	-	ms	$V_{DDIO} = 3.3V$

Table 7-2 shows MCLR circuit configuration. Capacitance (C1) is modified to change circuit's parameter.

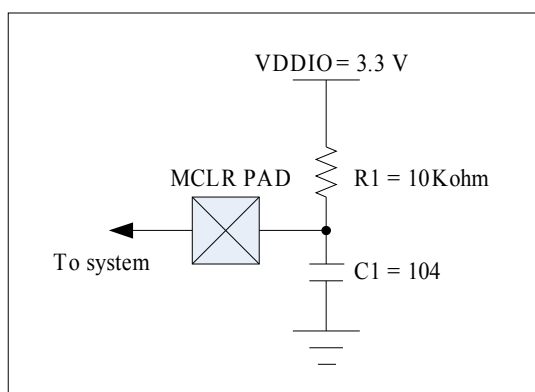

Figure 7-1: MCLR circuit configuration

7.3 DAC characteristics

Table 7-4: DAC characteristics

Symbol	Descriptions	Min	Typ	Max	Units	Conditions
Characteristics						
	SNR	-	85	-	db	
	Total Harmonic Distortion+Noise	-	80	-	db	
	DR(Dynamic Range)	-	86	-	db	
Power Specifications						
	Analog supply	3.0	3.3	3.6	V	
	Power Supply Current	-	5.89	-	mA	
	Sleep Current		51	600	nA	

7.4 Reset Characteristics

Table 7-5: Reset output AC parameters

Symbol	Descriptions	Min	Typ	Max	Units	Conditions
V_{por}	Power On Reset Voltage	-	1.2	-	V	VDD= 3.3V
V_{lvdr}	LVD Out Reset Voltage	-	2.2	-	V	EX_PIN, VDDIO = 3.3V LVDS = 11
		-	2.05	-	V	EX_PIN, VDDIO = 3.3V LVDS = 10
		-	1.95	-	V	EX_PIN, VDDIO = 3.3V LVDS = 01
		-	1.8	-	V	EX_PIN, VDDIO = 3.3V LVDS = 00
		-	3.3	-	V	VDDLDO, VDDIO = 3.3V LVDS = 11
		-	3.1	-	V	VDDLDO, VDDIO = 3.3V LVDS = 10
		-	2.9	-	V	VDDLDO, VDDIO = 3.3V LVDS = 01
		-	2.7	-	V	VDDLDO, VDDIO = 3.3V LVDS = 00

8 Ordering Code

Part No – S S S

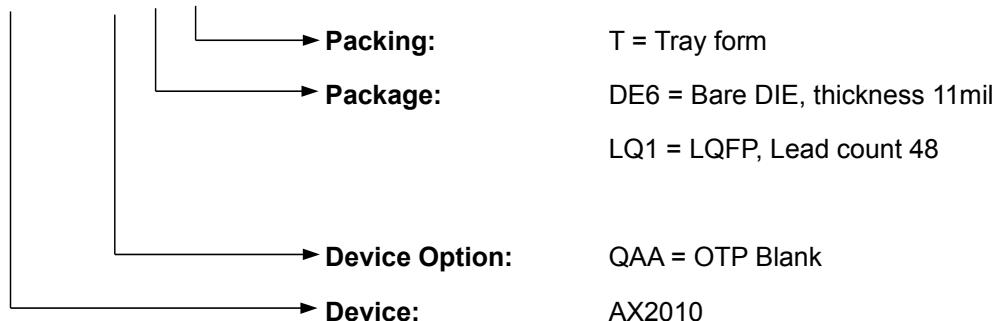

Ordering Code	Brief Description
AX2010-QAADE6T	Bare Die 11mil
AX2010-QAALQ1T	LQFP48

Please contact sales office (sales@appotech.com) for ordering procedures.

9 Appendix I Revision History

Date	Version	Comment	Revised by
2011-08-29	1.0.1	Updated document format	Erica Cheong
2012-01-17	1.0.2	Changed new logo Added ordering code	Erica Cheong

The information in this document is believed to be accurate in all respects at the time of publication but is subject to change without notice. AppoTech assumes no responsibility for errors and omissions, and disclaims responsibility for any consequences resulting from the use of information included herein. Additionally, AppoTech assumes no responsibility for the functioning of undescribed features or parameters. AppoTech reserves the right to make changes without further notice. AppoTech makes no warranty, representation or guarantee regarding the suitability of its products for any particular purpose, nor does AppoTech assume any liability arising out of the application or use of any product or circuit, and specifically disclaims any and all liability, including without limitation consequential or incidental damages. AppoTech products are not designed, intended, or authorized for use in applications intended to support or sustain life, or for any other application in which the failure of the AppoTech product could create a situation where personal injury or death may occur. Should Buyer purchase or use AppoTech products for any such unintended or unauthorized application, Buyer shall indemnify and hold AppoTech harmless against all claims and damages.

In case of any questions or comments about this documentation, please feel free to contact AppoTech at documents@appotech.com.