S12ZVML-MINIBRD User Manual: MC9S12ZVML128 Small Footprint Board for Sensorless Motor Control

Document Number: S12ZVML-MINIBRD_UM
1.0
04/2014





About This Book

This document describes the S12ZVML-MINIBRD, the MC9S12ZVML128 small footprint board design, which is targeted at BLDC and PMSM sensorless motor control applications.

To locate any published updates for this document, refer to [freescale.com](http://www.freescale.com).

Revision History

Table i. Revision History

| Date | Revision level | Description | Page number(s) |
|------------|----------------|-----------------|----------------|
| April 2014 | 1.0 | Initial release | 34 |

Documentation

The MC9S12ZVML128 documentation is available at the web site, <http://www.freescale.com/MagniV> as follows:

- Reference manuals — MC9S12ZVML128 modules in detail
- Data sheets — information mainly on the device's AC, DC, thermal characteristics and package pin-outs
- Product briefs — device overview
- Application notes — address specific design issues



Chapter 1 Introduction

| | | |
|-----|----------------------------|----|
| 1.1 | Board Features | 8 |
| 1.2 | Board Jumper Configuration | 11 |

Chapter 2 Board Interface Description

| | | |
|-----|-----------------------------------|----|
| 2.1 | J1 LIN Connector | 13 |
| 2.2 | J9 USB Connector | 13 |
| 2.3 | J2 MCU Digital Pin Header | 14 |
| 2.4 | J4 MCU Analog Pin Header | 14 |
| 2.5 | J7 MCU SCI Port Header | 14 |
| 2.6 | JP1, JP2, JP3 Motor Terminal Pins | 14 |

Chapter 3 Design Consideration

| | | |
|-----|-----------------------|----|
| 3.1 | Power Supply | 15 |
| 3.2 | MCU Related Circuitry | 15 |
| 3.3 | Charge Pumps | 15 |
| 3.4 | Load Current Sense | 16 |
| 3.5 | BDM Interface | 16 |
| 3.6 | OSBDM Interface | 16 |

Chapter 4 Board Electrical Characteristics

Chapter 5 Board Quick Start Guide

| | | |
|-------|--|----|
| 5.1 | Download the S12ZVML-MINIBRD Support Package | 19 |
| 5.2 | Software Tool Chain Set-up | 19 |
| 5.2.1 | BLDC Motor Control Software Package | 19 |
| 5.2.2 | CodeWarrior | 20 |
| 5.2.3 | FreeMASTER | 20 |
| 5.3 | Hardware Set-up | 20 |
| 5.4 | MCU Code Download and Debug | 20 |
| 5.5 | Run and Stop Motor Using External Interface | 21 |
| 5.6 | Control Motor Using FreeMASTER tool | 21 |

Chapter 6 References

Chapter 7 Acronyms

Chapter 8 S12ZVML-MINIBRD Schematic



Chapter 1 Introduction

This user manual introduces the S12ZVML-MINIBRD board, which represents the MC9S12ZVML128 small footprint board design.

The MC9S12ZVML128 [3.] integrates a 16-bit microcontroller, an automotive voltage regulator, a LIN interface and a gate driver unit, in order to drive six external MOSFETs.

The S12ZVML-MINIBRD board is designed for a 3-phase BLDC and PMSM sensorless motor control application. The board can be used for other applications requiring load switching and load current monitoring as well. An application can be controlled using LIN and FreeMASTER [4.].

For more information on BLDC sensorless applications, see AN4704 [7.].

1.1 Board Features

The board was designed to demonstrate the minimal hardware configuration needed for a 3-phase BLDC and PMSM sensorless motor control application to achieve minimum board size. The board features are as follows, see [Figure 1-1](#) and [Figure 1-2](#):

- MC9S12ZVML128 MCU
- power supply voltage in the range of -25 V to +25 V, nominal +12 V
- reverse battery protection
- load current in range of -10 A to +10 A
- load current monitoring
- boost circuitry designed to allow driving $V_{gs} = 10$ V MOSFETs from a +3.5 V power supply
- on-board charge pumps to allow driving the high side MOSFETs
- analog and digital inputs for target application control and monitoring
- FreeMASTER enabled
- LIN enabled
- BDM enabled
- OSBDM enabled:
 - download and debug MCU code
 - virtual serial line (USB to SCI)
- board size of 5 cm x 9 cm:
 - MC9S12ZVML128 related part size of 5 cm x 5 cm
 - OSBDM related part size of 5 cm x 4 cm

The on-board OSBDM module allows the user to download and debug code using the CW10.5 tool [5.] without the need of a P&E Micro USB Multilink.

The FreeMASTER tool allows the user to control the on-board application via the PC USB line.

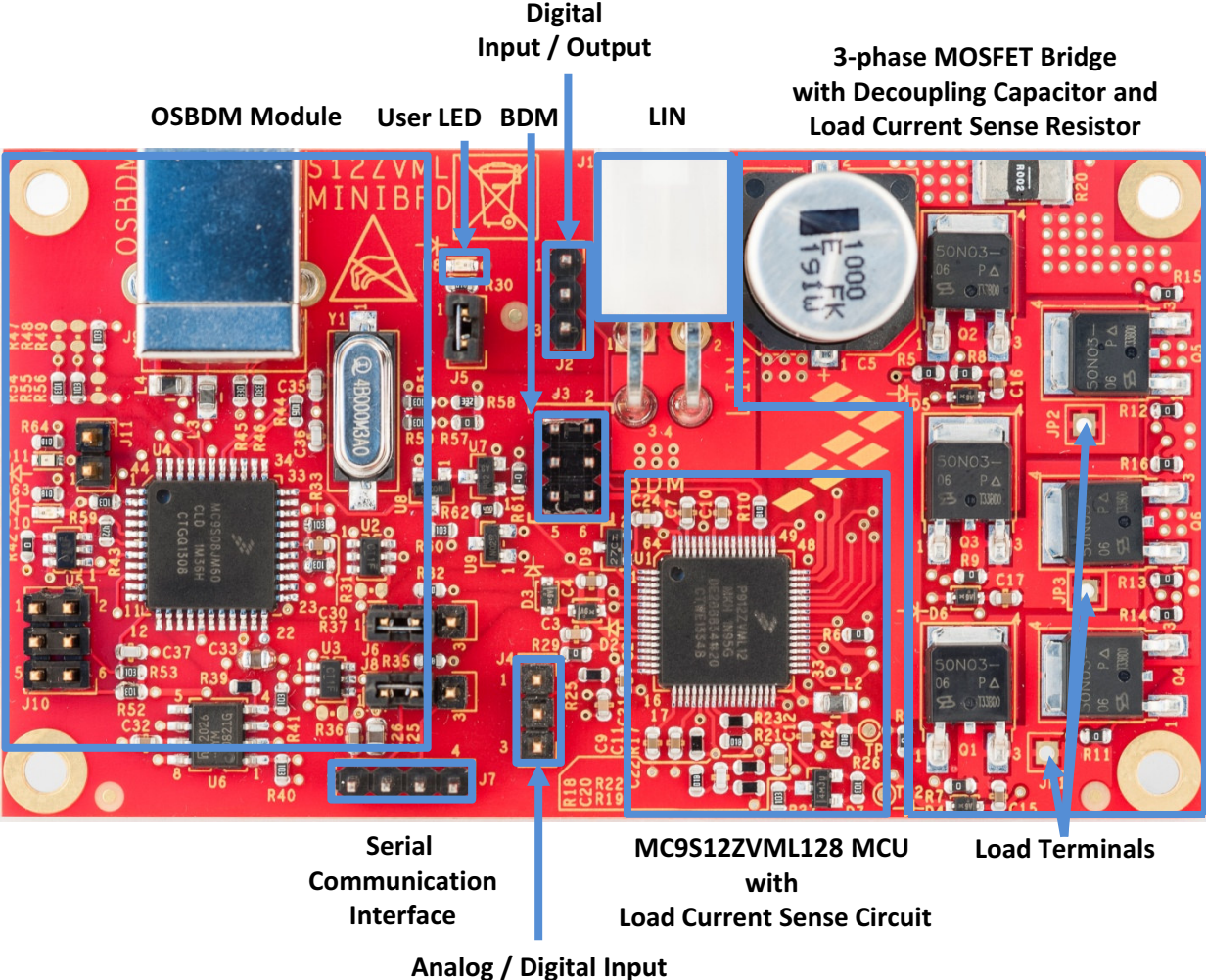

Figure 1-1. The S12ZVML-MINIBRD board top side view

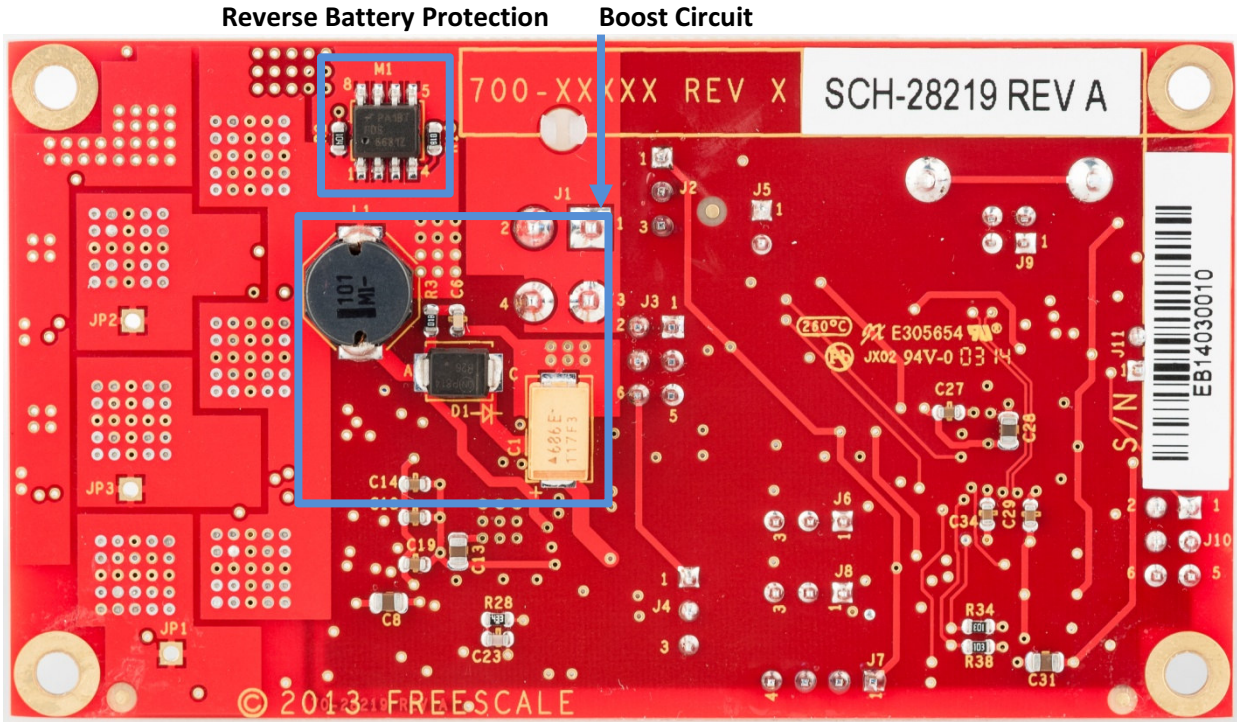

Figure 1-2. The S12ZVML-MINIBRD board bottom side view

1.2 Board Jumper Configuration

See [Table 1-1](#) and [Figure 1-3](#) for proper jumper configuration.

Table 1-1. S12ZVML-MINIBRD Board Configuration

| Jumper | MCU pin | Function | Default placement |
|--------|----------------------|---|-------------------|
| J5 | PP0 EVDD1 ECLK | MCU PP0 output: - ECLK, not placed - EVDD1, placed | Placed |
| J6 | PS2 RxD1 | Select MCU RxD1 pin connection: - USB OSBDM, placed, pins 1-2 - J7 SCI PORT, placed, pins 2-3 | Placed, pins 1-2 |
| J8 | PS3 TxD1 | Select MCU TxD1 pin connection: - USB OSBDM, placed, pins 1-2 - J7 SCI PORT, placed, pins 2-3 | Placed, pins 1-2 |

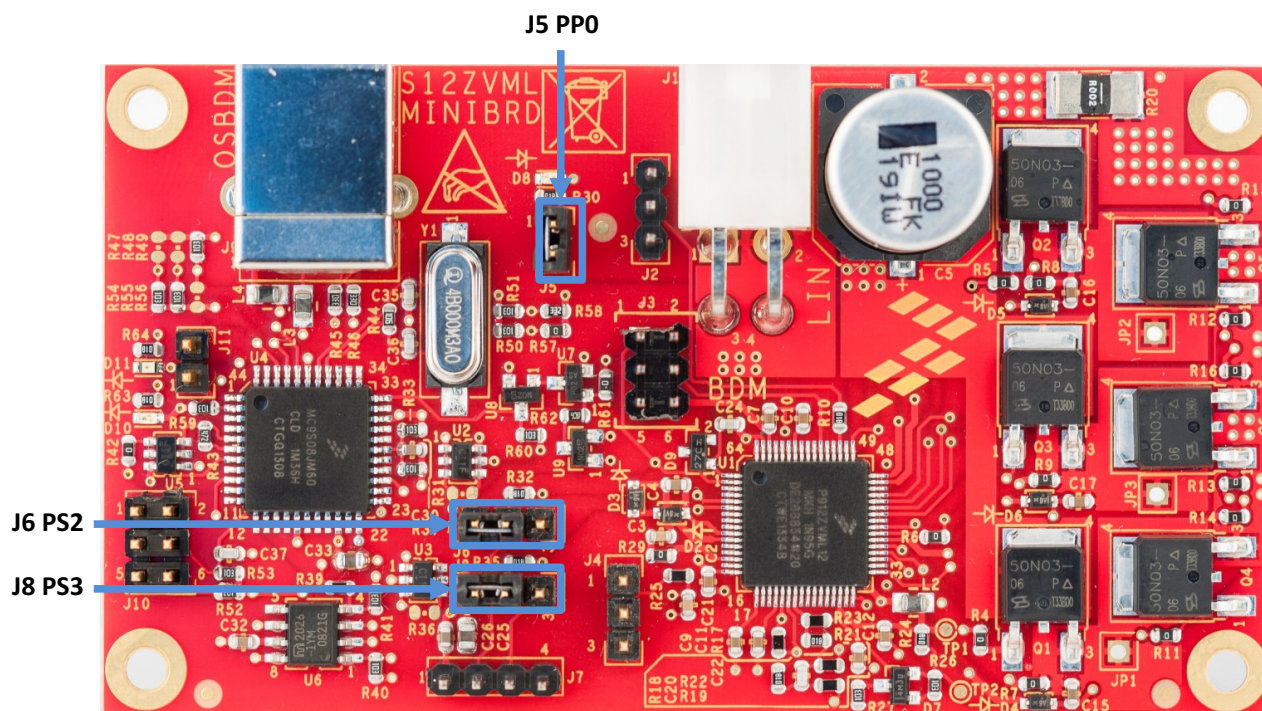

Figure 1-3. S12ZVML-MINIBRD board jumper position and setting

Chapter 2 Board Interface Description

This chapter summarizes the on-board connectors and header pin-outs, signal meanings, and MCU pins assignments.

2.1 J1 LIN Connector

The board is supplied using the LIN connector J1, see [Table 2-1](#) for the connector pin-outs. The MCU is configured as a LIN Slave node.

Table 2-1. J1 LIN connector

| Interface Pin | Signal Name | MCU Signal | Description | Direction |
|---------------|-------------|------------|--------------|---------------|
| 1 | GND | - | Ground | - |
| 2 | GND | - | Ground | - |
| 3 | VSUP | - | Power Supply | - |
| 4 | LIN | RXD1/TXD1 | LIN bus | Bidirectional |

The J1 LIN connector opposite uses MOLEX 39-01-2040 with pins MOLEX 39-00-0039.

2.2 J9 USB Connector

The USB line is used for on-board OSBDM module communication with the PC. The OSBDM module is used for MCU code download and debug using the CW 10.5 tool, as well as a virtual serial port when using the FreeMASTER tool to control the user application.

The interface uses a USB 2.0 B type connector, see [Table 2-2](#).

Table 2-2. J9 USB connector

| Interface Pin | Signal Name | MCU Signal | Description | Direction |
|---------------|-------------|------------|------------------|---------------|
| 1 | VBUS | - | USB Power Supply | - |
| 2 | D- | RXD0/TXD0 | Data – | Bidirectional |
| 3 | D+ | RXD0/TXD0 | Data + | Bidirectional |
| 4 | GNDB | - | USB Ground | - |

2.3 J2 MCU Digital Pin Header

The MCU PT1 digital pin can be used for an application control and monitoring, see [Table 2-3](#).

Table 2-3. 2 MCU PT1 pin header

| Interface Pin | Signal Name | MCU Signal | Description | Direction |
|---------------|-------------|------------|------------------------|---------------|
| 1 | VDDX | - | VDDX output (+5V) | - |
| 2 | - | PT1/IOC1 | PT1 pin input / output | Bidirectional |
| 3 | GND | - | GND | - |

2.4 J4 MCU Analog Pin Header

The MCU PAD3 analog pin can be used for an application control and monitoring, see [Table 2-4](#).

Table 2-4. J4 MCU PAD3 pin header

| Interface Pin | Signal Name | MCU Signal | Description | Direction |
|---------------|-------------|------------|-------------------|-----------|
| 1 | VDDX | - | VDDX output (+5V) | - |
| 2 | - | PAD3/AN0_3 | PAD3 pin input | Input |
| 3 | GND | - | GND | - |

2.5 J7 MCU SCI Port Header

The J7 allows to connect board external device using the MCU SCI module, see [Table 2-5](#). The MCU SCI port availability depends on the J6 and J8 configuration, see [Table 1-1](#).

Table 2-5. J7 MCU SCI port header

| Interface Pin | Signal Name | MCU Signal | Description | Direction |
|---------------|-------------|------------|--|-----------|
| 1 | VDDX | - | VDDX output (+5V) | - |
| 2 | RXD | RXD1 | Connection depending on J6 configuration | Input |
| 3 | TXD | TXD1 | Connection depending on J8 configuration | Output |
| 4 | GNDB | - | Ground | - |

2.6 JP1, JP2, JP3 Motor Terminal Pins

The JP1, JP2, JP3 are the phases half-bridge outputs. The terminals are used to connect the controlled load, for example BLDC, PMSM motor.

Chapter 3 Design Consideration

The S12ZVML-MINIBRD board schematic can be found in [Chapter 8, “S12ZVML-MINIBRD Schematic”](#).

3.1 Power Supply

The board is supplied using the J1 LIN connector, see [Table 1-1](#) for the connector pin-outs. The board nominal power supply voltage equals +12 V. The board sustains negative voltages up to -25 V due to M1 reverse battery protection.

The power supply line is decoupled by C5. The value of the capacitor is dependent on the required power supply voltage ripple, when board load, for example BLDC / PMSM motor, is PWM driven. The goal is to achieve minimum power supply voltage ripple to reduce board electromagnetic emissions.

An on-board boost circuit, L1, D1, C1, C2 allows controlling the $V_{gs} = 10$ V MOSFETs starting from a +3.5V power supply voltage. The boost circuitry is turned ON and controlled by the MCU GDU boost controller module when the power supply voltage drops below +10 V. The boost circuitry is optimized for operation at 520 kHz with the MCU GDU boost controller duty cycle set to 75% and the L1 inductor current limit at 750 mA. The boost snubber circuitry R3 and C6 is included to dump the oscillations appearing when the boost transistor is switched.

The on-board D7 +2.47 V voltage reference sets the ADC voltage, when the load current equals 0 A, see [Table 3-1](#).

3.2 MCU Related Circuitry

The MCU is supplied with VSUP pin. The MCU on-chip +5 V voltage regulator generates the voltage for the MCU digital and analog circuitry. The decoupling capacitors C7, C8, C9 reduce noise on the power supply lines. The MCU analog power supply line noise is reduced using the ferrite bead L2 and capacitor C12.

The GDU drives the Q1, Q2, Q3, Q4, Q5, Q6 MOSFETs configured in a 3-phase bridge unit with phase outputs JP1, JP2, JP3. The GDU is supplied by the on-chip +11 V VLS regulator decoupled by C13, C14, C18 and C19. Whenever the power supply voltage drops below +10 V, the boost circuitry starts to operate and the VSUP voltage is maintained at +10 V. The boost circuitry allows driving the $V_{gs} = 10$ V MOSFETs starting from a +3.5 V power supply voltage.

The J2 digital PT1 pin signal and J4 analog PAD3 signal can be used for an application monitoring and control.

The PP0 pin controls the D8 LED. The PP0 shares the MCU clock output ECLK as well.

The J7 allows to connect board external device using the MCU SCI module. The availability depends on J6 and J8 jumper header settings, see [Table 1-1](#).

3.3 Charge Pumps

There are four charge pumps to supply the GDU HSDs modules.

The D4, C15, D5, C16, D6, C17 charge pumps are driven by the phase voltages. They supply the GDU HSDs when the PWM duty cycle is within minimal and maximal limits.

The D2, D3, C3, C4 charge pump is driven by the MCU VCP pin. This is used to supply the GDU HSDs when the PWM duty cycle is either 0% or 100%.

3.4 Load Current Sense

The load current sense circuitry is designed to measure load current in both directions. This is useful when the attached motor is controlled in dynamo mode as well.

The load current is sensed by R20 and amplified by the on-chip amplifier AMP0. The R19, R22, and C20 reduce the sense line noise. The R28 and C23 shape the AMP0 signal.

The load current conversion slope theoretically equals 0.125 V/ 1 A, see [Table 3-1](#).

Table 3-1. Load current sense

| Load current [A] | MCU AN0 pin voltage [V] |
|------------------|-------------------------|
| 10 | 3.72 |
| 0 | 2.47 |
| -10 | 1.22 |

3.5 BDM Interface

The on-board J3 BDM connector allows a download and debug of the code in the MCU using CodeWarrior 10.5 and P&E Micro USB Multilink.

The BDM interface can be used for application control using FreeMASTER as well.

3.6 OSBDM Interface

The on-board OSBDM interface allows a download and debug of the code in the MCU without any additional debugging hardware. The P&E Micro USB Multilink is not needed.

The OSBDM interface can be used as a board virtual serial port for FreeMASTER based application control.

Chapter 4 Board Electrical Characteristics

The electrical characteristics in [Table 4-1](#) apply to operation at 25 °C.

Table 4-1. Electrical Characteristics

| Characteristic | Symbol | Min | Typ | Max | Units |
|--|-------------|-----|-----|-----|-------|
| Maximal power supply voltage range, J1 pin3 | V_{DCMAX} | -25 | - | 25 | V |
| Operating power supply voltage range, J1 pin3 ⁽¹⁾ | V_{DC} | 3.5 | 12 | 20 | V |
| Power supply current consumption ⁽²⁾ | I_{DC} | - | 20 | - | mA |
| J2 pin2, J4 pin2, J7 pin2, J7 pin3 voltage range | V_{PER} | 0 | - | 5 | V |

¹MCU boost option enabled. When MCU boost option disabled, $V_{DC_MIN} = 6V$.

²Measured at 12 V power supply. MCU flash memory erased.

Chapter 5 Board Quick Start Guide

This chapter describes how to set-up the S12ZVML-MINIBRD board to control the BLDC motor, see [Figure 5-1](#).

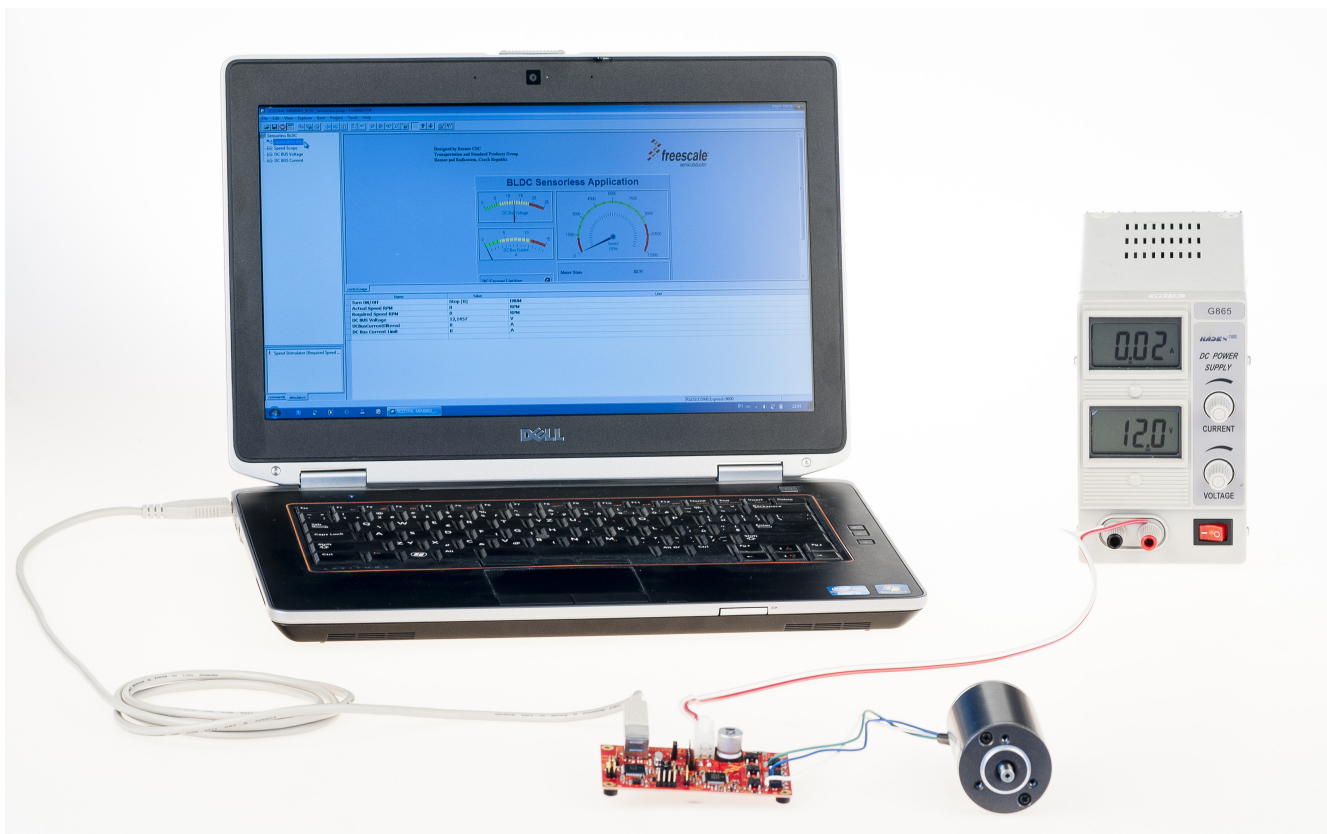

Figure 5-1. S12ZVML-MINIBRD set-up

5.1 Download the S12ZVML-MINIBRD Support Package

Visit the MagniV S12ZVML-MINIBRD related Freescale’s web pages [2.]. Navigate the “Jump Start Your Design” section and download the latest version of documentation and software package.

5.2 Software Tool Chain Set-up

5.2.1 BLDC Motor Control Software Package

Run the “S12ZVML-MINIBRD_BLDC_Sensorless_CW_IDE.exe” file and install and BLDC Motor Control project “S12ZVML-MINIBRD_BLDC_Sensorless_CW_IDE” and the Automotive Math and Motor Control Library Set [6.].

5.2.2 CodeWarrior

The CodeWarrior tool enables development, download and debug code in on-board MCU. Visit the CodeWarrior [5.] web page and install the free trial CW 10.5 version on your PC. Once the CW 10.5 is installed, import the “S12ZVML-MINIBRD_BLDC_Sensorless_CW_IDE” project in CW 10.5:

1. Open CW 10.5
2. Go to the “Help” folder and choose “Search”
3. Type in the search window the key words “Import existing project”
4. Follow the instructions to import the “S12ZVML-MINIBRD_BLDC_Sensorless_CW_IDE” project

For additional information:

1. Go to the “Help” folder and choose “Documentation”
2. Open the “Getting Started” folder
3. Download “Microcontroller V10.x Quick Start”

5.2.3 FreeMASTER

Install the free of charge FreeMASTER tool on your PC available at [4.]

5.3 Hardware Set-up

The S12ZVML-MINIBRD kit contains:

1. S12ZVML-MINIBRD board
2. J1 power supply cable, length 1 m
3. USB A male to B male cable, length 2 m

Follow instructions for board hardware set-up:

1. Check the S12ZVM-MINIBRD jumper settings, see [Table 1-1](#), [Figure 1-3](#).
1. Connect BLDC motor, type LINUX 45ZWN24-90-B, with the S12ZVML-MINIBRD, pins JP1, JP2, JP3, see [Figure 1-1](#) and [Figure 5-1](#)
2. Connect the power supply cable with the S12ZVML-MINIBRD, J1 LIN connector
3. Connect the power supply cable with the 12 V / 4 A power supply. The red wire goes to the positive terminal, the black wire (white wire) goes to the negative terminal
4. Turn ON the power supply
5. Connect the PC and S12ZVML-MINIBRD terminal J9 with a USB2.0 cable, type A to B

5.4 MCU Code Download and Debug

Create an OSBDM download profile, see the CW 10.5 project “Run” tab “Debug configuration”. Go to the “Run” tab, choose “Debug” and download code to the S12ZVML MCU using the on-board OSBDM module. Once the code is downloaded, go to “Run” and select “Resume” to run the code in MCU.

5.5 Run and Stop Motor Using External Interface

The motor can be controlled using the J2 header. Run motor by placing the jumper short bar to J2, pin 1-2.

5.6 Control Motor Using FreeMASTER tool

The motor can be controlled using the FreeMASTER tool, see [Figure 5-2](#):

1. Go to CodeWarrior 10.5 “Run” folder and select “Disconnect” to release the board USB channel. The USB communication channel will be used by FreeMASTER tool now
2. Place jumper short bar J2, pins 2-3
3. Search for the USB virtual port in the PC Device Manager
4. Open the FreeMASTER control page “S12ZVML-MINIBRD_BLDC_Sensorless.pmp” located in the “S12ZVML-MINIBRD_BLDC_Sensorless_CW_IDE” folder
5. Go to the Project/Options comm tab and set the USB virtual port number, and the communication speed 9600 kBd, see [Figure 5-3](#)
6. Run the communication by pressing CTRL+K
7. Enter the required BLDC motor rotation speed in the “Required Speed RPM” variable, range from 1500 rpm to 8000 rpm at 12 V power supply
8. Run / Stop motor by variable “Turn ON/OFF”
9. Analyze motor behavior in the “Speed Scope” window
10. Monitor the DC BUS Voltage (module power supply voltage) and DC BUS Current (motor current)

For more information on BLDC sensorless applications, see AN4704 [7.].

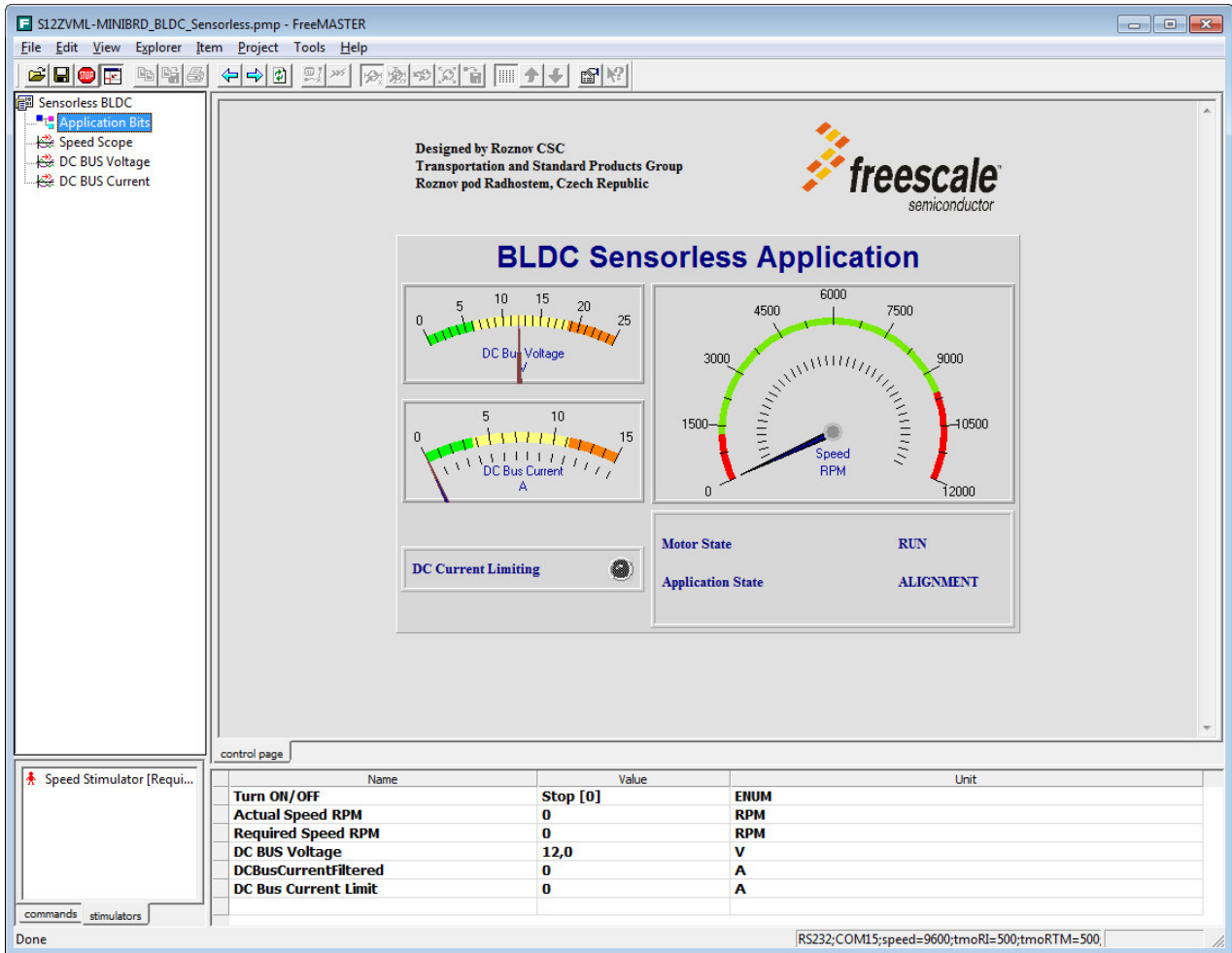

Figure 5-2. FreeMASTER control page

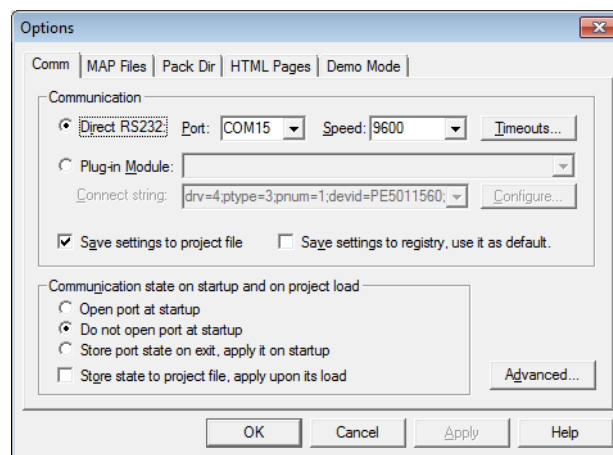

Figure 5-3. FreeMASTER options communication tab

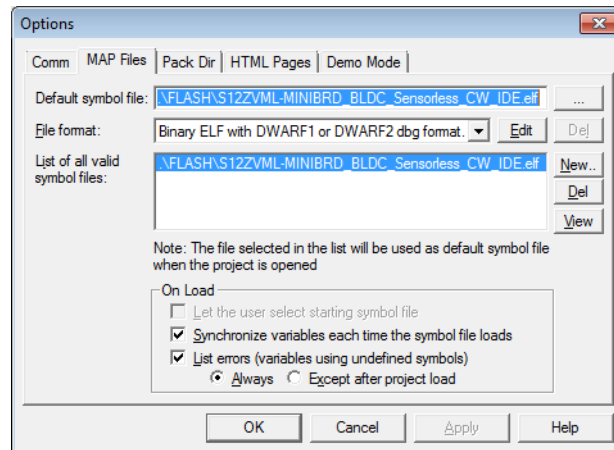

Figure 5-4. FreeMASTER options map file tab



Chapter 6 References

1. MagniV family web page, www.freescale.com/MagniV
2. S12ZVML-MINIBRD web page, www.freescale.com/S12ZVML-MINIBRD
3. MC9S12ZVM Family Reference Manual, www.freescale.com
4. FreeMASTER Run-Time Debugging Tool, www.freescale.com/freemaster
5. CodeWarrior Development Tools, www.freescale.com/codewarrior
6. Automotive Math and Motor Control Library Set, www.freescale.com/AutoMCLib
7. AN4704, 3-phase Sensorless BLDC Motor Control Kit with MC9S12ZVM, www.freescale.com

Chapter 7 Acronyms

| | |
|------|------------------------------------|
| ADC | Analog to Digital Converter |
| BLDC | Brushless DC Motor |
| CW | CodeWarrior Tool |
| HSD | High Side Driver |
| LIN | Local Interconnect Network |
| MCU | Microcontroller Unit |
| PC | Personal Computer |
| PWM | Pulse Width Modulation |
| PMSM | Permanent Magnet Synchronous Motor |
| USB | Universal Serial Bus |

Chapter 8 S12ZVML-MINIBRD Schematic

| 5 | 4 | 3 | 2 | 1 | | | | | | | | | | | | | | | | | | | | | | | | | | | | | | | | | | | | | | | | |
|---|---|---|------------|---|---|---|--|--|------|------------------|--|------|------------------|----------------------------|----|------------------|-----------|---|-----------|---------------------------------|---------------|-----------------------|-----|---|----|------------|------------|----------|--|--|--|--|--|--|--|--|--|--|--|--|--|--|--|---|
| D | <table border="1" style="margin: auto;"> <thead> <tr> <th colspan="5">SCHEMATIC REVISIONS</th> </tr> <tr> <th>Zone</th> <th>Rev</th> <th>Description</th> <th>Date</th> <th>Revised</th> </tr> </thead> <tbody> <tr> <td>All</td> <td>X1</td> <td>Initial version</td> <td>9.12.2013</td> <td>PCh</td> </tr> <tr> <td></td> <td>A</td> <td>First release</td> <td>19.12.2013</td> <td>PCh</td> </tr> <tr> <td></td> <td>A1</td> <td>BOM Change</td> <td>12.02.2014</td> <td>Simon Xu</td> </tr> <tr> <td> </td> <td> </td> <td> </td> <td> </td> <td> </td> </tr> <tr> <td> </td> <td> </td> <td> </td> <td> </td> <td> </td> </tr> <tr> <td> </td> <td> </td> <td> </td> <td> </td> <td> </td> </tr> </tbody> </table> | | | SCHEMATIC REVISIONS | | | | | Zone | Rev | Description | Date | Revised | All | X1 | Initial version | 9.12.2013 | PCh | | A | First release | 19.12.2013 | PCh | | A1 | BOM Change | 12.02.2014 | Simon Xu | | | | | | | | | | | | | | | | D |
| SCHEMATIC REVISIONS | | | | | | | | | | | | | | | | | | | | | | | | | | | | | | | | | | | | | | | | | | | | |
| Zone | Rev | Description | Date | Revised | | | | | | | | | | | | | | | | | | | | | | | | | | | | | | | | | | | | | | | | |
| All | X1 | Initial version | 9.12.2013 | PCh | | | | | | | | | | | | | | | | | | | | | | | | | | | | | | | | | | | | | | | | |
| | A | First release | 19.12.2013 | PCh | | | | | | | | | | | | | | | | | | | | | | | | | | | | | | | | | | | | | | | | |
| | A1 | BOM Change | 12.02.2014 | Simon Xu | | | | | | | | | | | | | | | | | | | | | | | | | | | | | | | | | | | | | | | | |
| | | | | | | | | | | | | | | | | | | | | | | | | | | | | | | | | | | | | | | | | | | | | |
| | | | | | | | | | | | | | | | | | | | | | | | | | | | | | | | | | | | | | | | | | | | | |
| | | | | | | | | | | | | | | | | | | | | | | | | | | | | | | | | | | | | | | | | | | | | |
| C | | | | C | | | | | | | | | | | | | | | | | | | | | | | | | | | | | | | | | | | | | | | | |
| B | | | | B | | | | | | | | | | | | | | | | | | | | | | | | | | | | | | | | | | | | | | | | |
| A | <table border="1" style="width: 100%; border-collapse: collapse;"> <tr> <td style="width: 30%; text-align: center;">  </td> <td style="width: 70%;"> Freescale Semiconductor RCSC 1. maje 1009 765 61 Roznov p. R. Czech republic, Europe </td> </tr> <tr> <td colspan="2"> This document contains information proprietary to Freescale Semiconductor and shall not be used for engineering design, procurement or manufacture in whole or in part without the express written permission of Freescale Semiconductor. </td> </tr> <tr> <td colspan="2" style="text-align: center;"> ICAP Classification: FCP: FIUO: PUBI: X </td> </tr> <tr> <td style="width: 30%;"> Designer: PCh </td> <td colspan="2"> Drawing Title: S12ZVML_MINIBRD </td> </tr> <tr> <td> Drawn by: PCh </td> <td colspan="2"> Page Title: Info </td> </tr> <tr> <td> Approved: PCh </td> <td style="width: 30%;"> Size A </td> <td style="width: 40%;"> Document Number SCH-28219 PDF: SPF-28219 </td> <td style="width: 10%;"> Rev A1 </td> </tr> <tr> <td colspan="2"> Date: Monday, March 31, 2014 </td> <td colspan="2" style="text-align: right;"> Sheet 1 of 3 </td> </tr> </table> | | |  | Freescale Semiconductor RCSC 1. maje 1009 765 61 Roznov p. R. Czech republic, Europe | This document contains information proprietary to Freescale Semiconductor and shall not be used for engineering design, procurement or manufacture in whole or in part without the express written permission of Freescale Semiconductor. | | ICAP Classification: FCP: FIUO: PUBI: X | | Designer: PCh | Drawing Title: S12ZVML_MINIBRD | | Drawn by: PCh | Page Title: Info | | Approved: PCh | Size A | Document Number SCH-28219 PDF: SPF-28219 | Rev A1 | Date: Monday, March 31, 2014 | | Sheet 1 of 3 | | A | | | | | | | | | | | | | | | | | | | | |
|  | Freescale Semiconductor RCSC 1. maje 1009 765 61 Roznov p. R. Czech republic, Europe | | | | | | | | | | | | | | | | | | | | | | | | | | | | | | | | | | | | | | | | | | | |
| This document contains information proprietary to Freescale Semiconductor and shall not be used for engineering design, procurement or manufacture in whole or in part without the express written permission of Freescale Semiconductor. | | | | | | | | | | | | | | | | | | | | | | | | | | | | | | | | | | | | | | | | | | | | |
| ICAP Classification: FCP: FIUO: PUBI: X | | | | | | | | | | | | | | | | | | | | | | | | | | | | | | | | | | | | | | | | | | | | |
| Designer: PCh | Drawing Title: S12ZVML_MINIBRD | | | | | | | | | | | | | | | | | | | | | | | | | | | | | | | | | | | | | | | | | | | |
| Drawn by: PCh | Page Title: Info | | | | | | | | | | | | | | | | | | | | | | | | | | | | | | | | | | | | | | | | | | | |
| Approved: PCh | Size A | Document Number SCH-28219 PDF: SPF-28219 | Rev A1 | | | | | | | | | | | | | | | | | | | | | | | | | | | | | | | | | | | | | | | | | |
| Date: Monday, March 31, 2014 | | Sheet 1 of 3 | | | | | | | | | | | | | | | | | | | | | | | | | | | | | | | | | | | | | | | | | | |
| 5 | 4 | 3 | 2 | 1 | | | | | | | | | | | | | | | | | | | | | | | | | | | | | | | | | | | | | | | | |

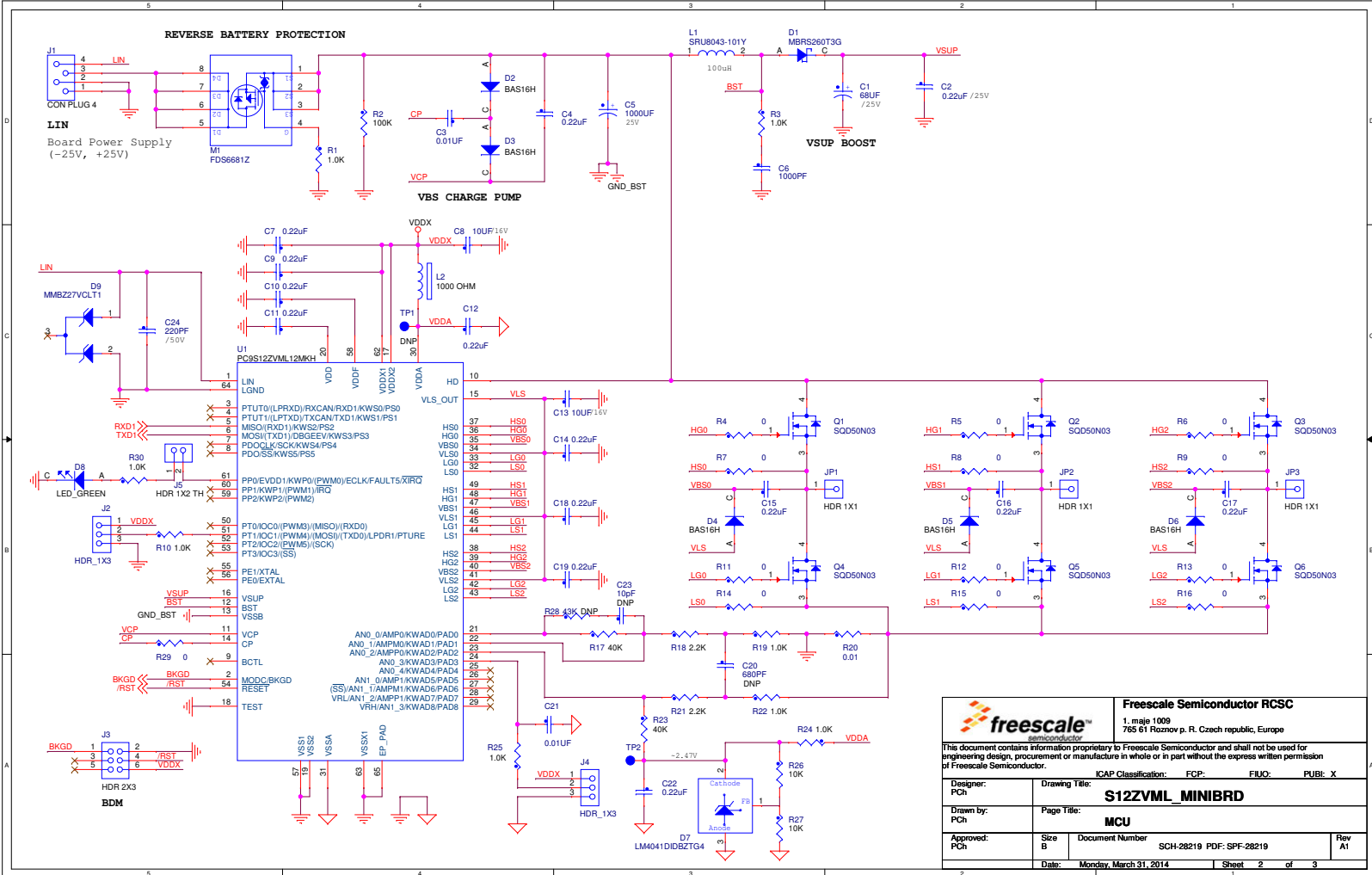

| | | | |
|------------------------------|--|--|--------------|
| | | Freescale Semiconductor RCSC 1. mje 1009 785 61 Roznov p. R. Czech republic, Europe | |
| | | <small>This document contains information proprietary to Freescale Semiconductor and shall not be used for engineering design, procurement or manufacture in whole or in part without the express written permission of Freescale Semiconductor.</small> | |
| Designer: PCb | Drawing Title: S12ZVML_MINIBRD | ICAP Classification: FQP: | FIUQ: PUB: X |
| Drawn by: PCb | Page Title: MCU | | |
| Approved: PCb | Size B | Document Number SCH-28219 PDF: SPF-28219 | Rev A1 |
| Date: Monday, March 31, 2014 | | Sheet 2 of 3 | |

S12ZVML-MINIBRD Board User Manual, Rev. 1.0

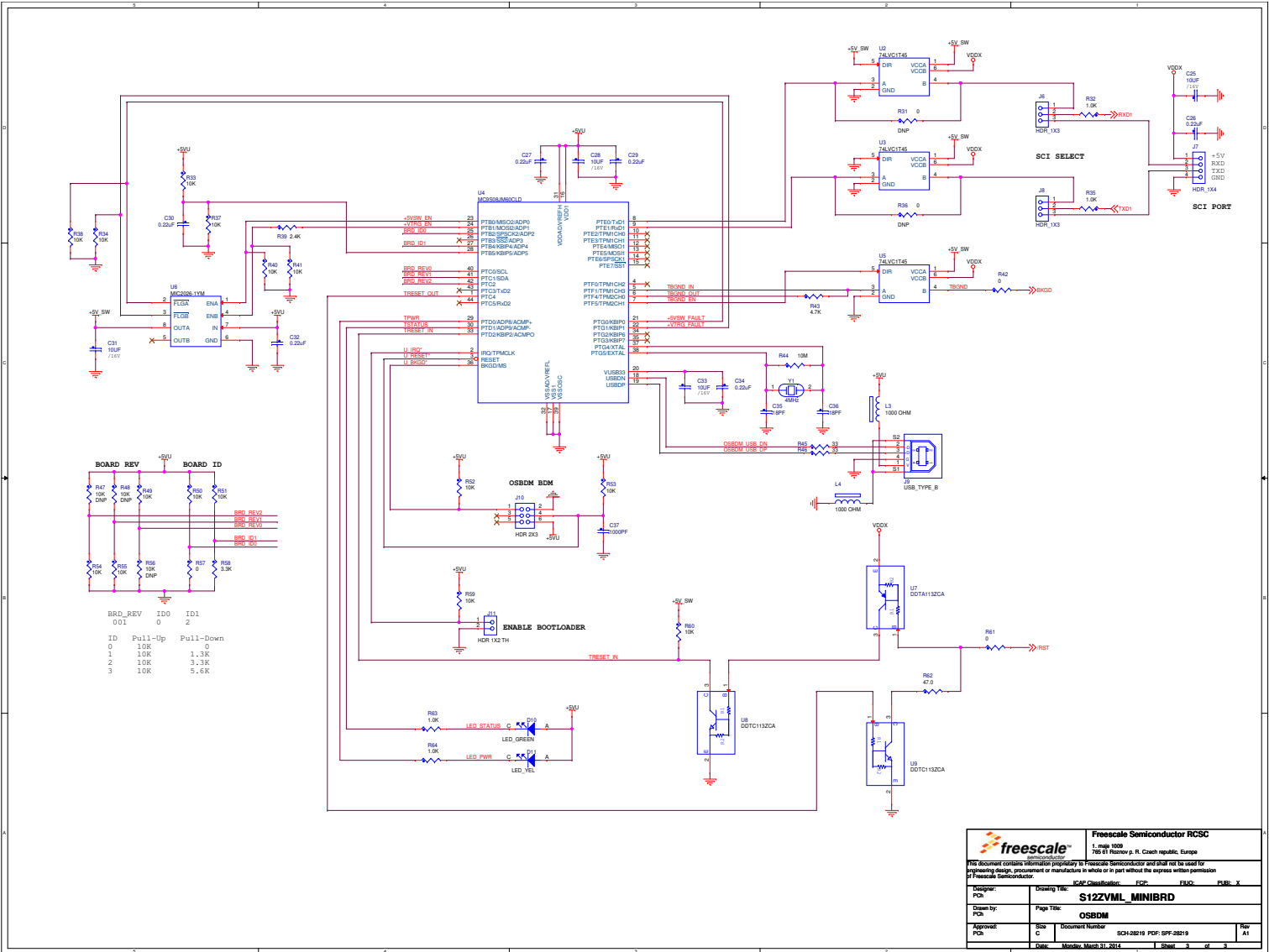

| | | | |
|---|--|---|-------------------------------------|
| | | Freescal Semiconductor RCSC 1, rue 1009 750 81 Reuven p. R. Coax repelle, Europe Freescal Semiconductor | |
| This document contains information proprietary to Freescal Semiconductor and shall not be used for engineering design, procurement or manufacture in whole or in part without the express written permission of Freescal Semiconductor. | | | |
| Designer: PCB | Drawing No.: S12ZVML_MINIBRD | CAP Classification: FCP | EIND: PSE: X |
| Drawn by: PCB | Page Title: OSBDM | Approval: PCB | Document Number: S12ZVML_MINIBRD |
| Date: Monday, March 21, 2011 | Sheet: 3 of 3 | Rev: A1 | Date: Monday, March 21, 2011 |

How to Reach Us:

Home Page:

www.freescale.com

Web Support:

<http://www.freescale.com/support>

USA/Europe or Locations Not Listed:

Freescale Semiconductor, Inc.
Technical Information Center, EL516
2100 East Elliot Road
Tempe, Arizona 85284
1-800-521-6274 or +1-480-768-2130
www.freescale.com/support

Europe, Middle East, and Africa:

Freescale Halbleiter Deutschland GmbH
Technical Information Center
Schatzbogen 7
81829 Muenchen, Germany
+44 1296 380 456 (English)
+46 8 52200080 (English)
+49 89 92103 559 (German)
+33 1 69 35 48 48 (French)
www.freescale.com/support

Japan:

Freescale Semiconductor Japan Ltd. Headquarters
ARCO Tower 15F
1-8-1, Shimo-Meguro, Meguro-ku,
Tokyo 153-0064
Japan
0120 191014 or +81 3 5437 9125
support.japan@freescale.com

Asia/Pacific:

Freescale Semiconductor China Ltd.
Exchange Building 23F
No. 118 Jianguo Road
Chaoyang District
Beijing 100022
China
+86 10 5879 8000
support.asia@freescale.com

Freescale Semiconductor Literature Distribution Center
1-800-441-2447 or +1-303-675-2140
Fax: +1-303-675-2150
LDCForFreescaleSemiconductor@hibbertgroup.com

Information in this document is provided solely to enable system and software implementers to use Freescale Semiconductor products. There are no express or implied copyright licenses granted hereunder to design or fabricate any integrated circuits or integrated circuits based on the information in this document.

Freescale Semiconductor reserves the right to make changes without further notice to any products herein. Freescale Semiconductor makes no warranty, representation or guarantee regarding the suitability of its products for any particular purpose, nor does Freescale Semiconductor assume any liability arising out of the application or use of any product or circuit, and specifically disclaims any and all liability, including without limitation consequential or incidental damages. "Typical" parameters that may be provided in Freescale Semiconductor data sheets and/or specifications can and do vary in different applications and actual performance may vary over time. All operating parameters, including "Typicals", must be validated for each customer application by customer's technical experts. Freescale Semiconductor does not convey any license under its patent rights nor the rights of others. Freescale Semiconductor products are not designed, intended, or authorized for use as components in systems intended for surgical implant into the body, or other applications intended to support or sustain life, or for any other application in which the failure of the Freescale Semiconductor product could create a situation where personal injury or death may occur. Should Buyer purchase or use Freescale Semiconductor products for any such unintended or unauthorized application, Buyer shall indemnify and hold Freescale Semiconductor and its officers, employees, subsidiaries, affiliates, and distributors harmless against all claims, costs, damages, and expenses, and reasonable attorney fees arising out of, directly or indirectly, any claim of personal injury or death associated with such unintended or unauthorized use, even if such claim alleges that Freescale Semiconductor was negligent regarding the design or manufacture of the part.

Freescale™ and the Freescale logo are trademarks of Freescale Semiconductor, Inc. All other product or service names are the property of their respective owners.

© Freescale Semiconductor, Inc. 2014. All rights reserved.

S12ZVML-MINIBRD_UM
Rev. 1.0
04/2014

