



Robohead X-3 LED  
moving head

Musikhaus Thomann e.K.

Treppendorf 30

96138 Burgebrach

Germany

Telephone: +49 (0) 9546 9223-0

E-mail: [info@thomann.de](mailto:info@thomann.de)

Internet: [www.thomann.de](http://www.thomann.de)

26.10.2012

## Table of contents

<b>1</b>	<b>General notes</b> .....	<b>5</b>
<b>2</b>	<b>Safety instructions</b> .....	<b>8</b>
<b>3</b>	<b>Features</b> .....	<b>13</b>
<b>4</b>	<b>Installation</b> .....	<b>15</b>
<b>5</b>	<b>Starting up</b> .....	<b>21</b>
<b>6</b>	<b>Connections and operating elements</b> .....	<b>24</b>
<b>7</b>	<b>Operation</b> .....	<b>28</b>
	7.1 Starting the device.....	28
	7.2 Main menu.....	29
	7.3 Settings menu.....	38
	7.4 Gobos.....	43
	7.5 Functions in 11-channel DMX mode.....	44
	7.6 Functions in 16-channel DMX mode.....	51
<b>8</b>	<b>Cleaning</b> .....	<b>60</b>

<b>9</b>	<b>Troubleshooting.....</b>	<b>61</b>
<b>10</b>	<b>Technical specifications.....</b>	<b>63</b>
<b>11</b>	<b>Protecting the environment.....</b>	<b>64</b>

# 1 General notes





This user manual contains important information on safe operation of the device. Read and follow all safety notes and all instructions. Save this manual for future reference. Make sure that it is available to all persons using this device. If you sell the device, include the manual for the next owner.

Our products are subject to a process of continuous development. We therefore reserve the right to make changes without notice.

## **Symbols and signal words**

This section provides an overview of the symbols and signal words used in this user manual.

<b>Signal word</b>	<b>Meaning</b>
<b>DANGER!</b>	This combination of symbol and signal word indicates an immediate dangerous situation that will result in death or serious injury if it is not avoided.
<b>WARNING!</b>	This combination of symbol and signal word indicates a possible dangerous situation that can result in death or serious injury if it is not avoided.
<b>CAUTION!</b>	This combination of symbol and signal word indicates a possible dangerous situation that can result in minor injury if it is not avoided.
<b>NOTICE!</b>	This combination of symbol and signal word indicates a possible dangerous situation that can result in material and environmental damage if it is not avoided.

Warning signs	Type of danger
 A yellow triangular warning sign with a black border and a black lightning bolt symbol in the center.	Warning – high-voltage.
 A yellow triangular warning sign with a black border and three wavy lines representing heat in the center.	Warning – hot surface.
 A yellow triangular warning sign with a black border and a black symbol of a crane hook lifting a load in the center.	Warning – suspended load.
 A yellow triangular warning sign with a black border and a black exclamation mark in the center.	Warning – danger zone.

## 2 Safety instructions

### Intended use

This device is intended to be used as moving-head spotlight. Use the device only as described in this user manual. Any other use or use under other operating conditions is considered to be improper and may result in personal injury or property damage. No liability will be assumed for damages resulting from improper use.

This device may be used only by persons with sufficient physical, sensorial, and intellectual abilities and having corresponding knowledge and experience. Other persons may use this device only if they are supervised or instructed by a person who is responsible for their safety.

### Safety



#### **DANGER!**

#### **Danger for children**

Ensure that plastic bags, packaging, etc. are disposed of properly and are not within reach of babies and young children. Choking hazard!

Ensure that children do not detach any small parts (e.g. knobs or the like) from the unit. They could swallow the pieces and choke!

Never let children unattended use electrical devices.





**DANGER!**

**Electric shock caused by high voltages inside**

Within the device there are areas where high voltages may be present. Never remove any covers.

There are no user-serviceable parts inside.



**DANGER!**

**Electric shock caused by short-circuit**

Always use proper ready-made insulated mains cabling (power cord) with a protective contact plug. Do not modify the mains cable or the plug. Failure to do so could result in electric shock/death or fire. If in doubt, seek advice from a registered electrician.



**WARNING!**

**Eye damage caused by high light intensity**

Never look directly into the light source.



**WARNING!**

**Risk of epileptic shock**

Strobe lighting can trigger seizures in photosensitive epilepsy. Sensitive persons should avoid looking at strobe lights.



**WARNING!**

**Risk of burns**

The surface of the device can become very hot during operation.

Do not touch the device with bare hands during operation, and after switching off wait for at least 15 minutes.



**CAUTION!**

**Risk of injury due to movements of the device**

The head of the device can move quickly (pan, tilt) and can produce very bright light. This is also valid immediately after you turn on the device, when the device operates in automatic mode or under remote control and when you turn off a DMX controller that is connected to the device. Persons staying near the device could be injured or frightened.

Before you turn on the device and during the operation, always ensure that nobody stays close to the device. If work has to be performed in the area of movement or in the near vicinity of the device, it must remain turned off.



**NOTICE!**

**Risk of fire**

Do not cover the device nor any ventilation slots. Do not place the device near any direct heat source. Keep the device away from naked flames.



### **NOTICE!**

#### **Operating conditions**

This device has been designed for indoor use only. To prevent damage, never expose the device to any liquid or moisture. Avoid direct sunlight, heavy dirt, and strong vibrations.



### **NOTICE!**

#### **Power supply**

Before connecting the device, ensure that the input voltage (AC outlet) matches the voltage rating of the device and that the AC outlet is protected by a residual current circuit breaker. Failure to do so could result in damage to the device and possibly injure the user.

Unplug the device before electrical storms occur and when it is unused for long periods of time to reduce the risk of electric shock or fire.

## 3 Features

This Moving Head is specially suited for professional lighting, e.g. at events, on rock stages, in theatres, musicals or discos.

Special features of the device:

- Three axes of movement with 8 or 16 bit resolution:
  - Tilt (540 °)
  - Pan 1 (540 °)
  - Pan 2 (540 °)
- Control via DMX (11 or 16 channels) and via buttons and display on the unit
- Built-in automatic show programmes
- Sound control
- Master / slave mode
- Colour wheel with white, 8 full colours, 8 split colours and rainbow effect
- Gobo wheel with 7 rotatable gobos
- Gobo shake function
- Effects wheel with triple prism
- Electronic dimmer

- Shutter frequency: 0...13 Hz
- Automatic position correction

## 4 Installation

Unpack and check carefully there is no transportation damage before using the unit. Keep the equipment packaging. To fully protect the device against vibration, dust and moisture during transportation or storage use the original packaging or your own packaging material suitable for transport or storage, respectively.



### **WARNING!**

#### **Risk of injury by falling off**

Make sure that the installation complies with the standards and rules that apply in your country. Always secure the device with a secondary safety attachment, such as a safety cable or a safety chain.

The carrying capacity of the truss or other mounting must be sufficient for the intended number of devices. Note that the movement of the head may additionally stress the load-bearing structures.



## **CAUTION!**

### **Risk of injury due to movements of the device**

The head of the device can move quickly (pan, tilt) and can produce very bright light. This is also valid immediately after you turn on the device, when the device operates in automatic mode or under remote control and when you turn off a DMX controller that is connected to the device. Persons staying near the device could be injured or frightened.

Before you turn on the device and during the operation, always ensure that nobody stays close to the device. If work has to be performed in the area of movement or in the near vicinity of the device, it must remain turned off.



## **NOTICE!**

### **Risk of overheating**

The distance between the light output and the illuminated surface must be more than 0.5 m (19.7 in).

Always ensure sufficient ventilation.

The ambient temperature must always be below 40 °C (104 °F).



**NOTICE!****Possible damage caused by movements of the device**

Always ensure that enough space is free around the device for the movements of the head (pan, tilt).

**NOTICE!****Possible data transmission errors**

For error-free operation make use of dedicated DMX cables and do not use ordinary microphone cables.

Never connect the DMX output to audio devices such as mixers or amplifiers.

***Axes of movement***

*When the unit is not connected to the power grid, the head is freely movable around the tilt and pan axes. This may especially in standing mounting lead to unexpected movements of the head after switching the device off.*

## DMX connections



The unit offers a 3-pin XLR socket for DMX output and a 3-pin XLR plug for DMX input. Please refer to the drawing and table below for pin assignment.

1	Ground, shielding
2	DMX data (-)
3	DMX data (+)

## Mounting options

You can install the unit on the ceiling or on the floor. A mounting bracket and the necessary screws are included.



*The device is not suitable for wall mounting.*

The threads on the bottom side of the housing allow the secure attachment of the bracket or truss clamps. Safety-ropes can be routed through the notches on the bottom of the housing, as shown in the following figure.

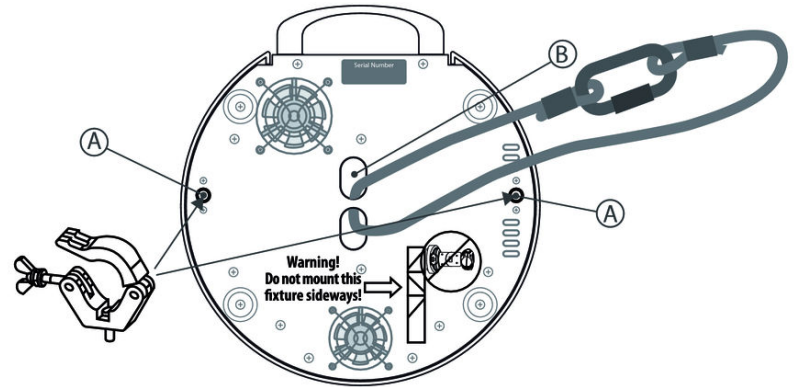

A Threads for the supplied bracket or truss clamps

B Safety-rope openings

## 5 Starting up

Establish all connections as long as the unit is switched off. Use the shortest possible high-quality cables for all connections.

### Connections in DMX mode

Connect the DMX input of the device to the DMX output of a DMX controller or another DMX device. Connect the output of the first DMX device to the input of the second one, and so on to form a daisy chain. Always ensure that the output of the last DMX device in the daisy chain is terminated with a resistor ( $110\ \Omega$ ,  $\frac{1}{4}\text{ W}$ ).

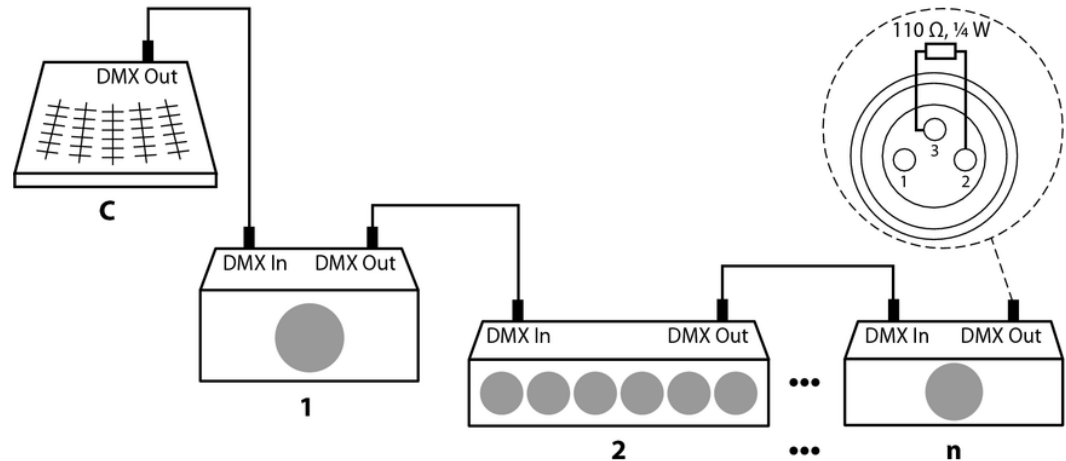

**DMX indicator**

If the device and the DMX controller are in operation, the DMX indicator shows an incoming DMX signal at the input.

**Connections in master/slave mode**

When you configure a group of devices in master/slave mode, the first unit will control the other units for an automatic, sound-activated, synchronized show. This function is ideal when you want to start a show immediately. Connect the DMX output of the master device to the DMX input of the first slave device. Then connect the DMX output of the first slave device to the DMX input of the second slave device and so on.

## 6 Connections and operating elements

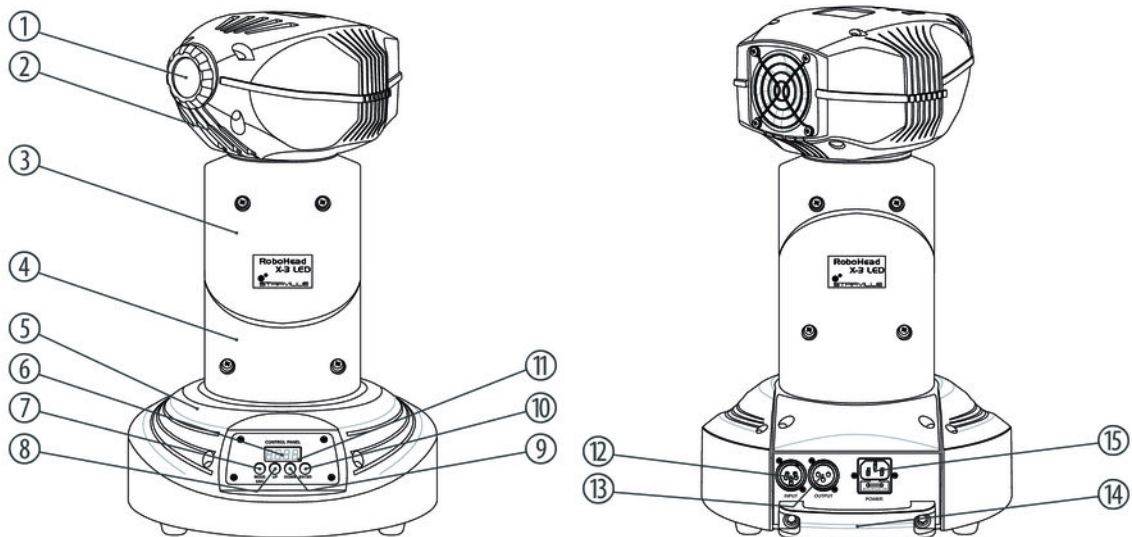



1	Light aperture with projection lens.
2	Moving head.
3, 4	Moving arm.
5	Device base.
6	Display.
7	<i>[MODE/ESC]</i> button Activates the main and the settings menu and changes between the menu items. Closes an open menu without saving the changes.
8	<i>[UP]</i> button Increases the displayed value by one.
9	<i>[DOWN]</i> button Decreases the displayed value by one.

10	<i>[ENTER]</i> button Selects an option of the respective operating mode, confirms the set value.
11	DMX indicator This LED indicates an incoming DMX signal.
12	<b>INPUT</b> DMX input.
13	<b>OUTPUT</b> DMX output.
14	Carrying handle.
15	<b>POWER</b> IEC chassis connector with fuse holder.

**Axes of movement**

The figure below shows the three axes of movement of the device.

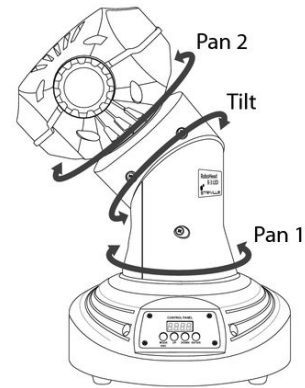

## 7 Operation

### 7.1 Starting the device



#### **CAUTION!**

#### **Risk of injury due to movements of the device**

The head of the device can move quickly (pan, tilt) and can produce very bright light. This is also valid immediately after you turn on the device, when the device operates in automatic mode or under remote control and when you turn off a DMX controller that is connected to the device. Persons staying near the device could be injured or frightened.

Before you turn on the device and during the operation, always ensure that nobody stays close to the device. If work has to be performed in the area of movement or in the near vicinity of the device, it must remain turned off.

Connect the device to the power grid to start operation. After a few seconds, the fans start to work and the head moves to the pan (rotation) and tilt (inclination) home position. After some more seconds the display shows 'd001'. Now the device is operational.

## 7.2 Main menu

Press *[MODE/ESC]* (for about 30 seconds if running DMX controlled) to open the main menu. Press *[MODE/ESC]* again to select a menu item.

Use the *[UP]* and *[DOWN]* buttons to change the respectively indicated value. When the display shows the desired value, press *[ENTER]*. To return to the main menu without any changes, press either *[MODE/ESC]* or wait a minute.

If you don't press any button for about one minute, the display turns dark. Then briefly pressing *[MODE/ESC]* will turn it on again.

All previous settings are saved, even if you turn the device off and disconnect it from the mains. To restart with standard values, use the *'Load default'* function (↻ *'Loading default values'* on page 36).

### DMX address

Repeatedly press *[MODE/ESC]* until the display shows 'dxxx'. Now you can set the number of the first DMX channel to be used by the device (DMX address). Use *[UP]* and *[DOWN]* to select a value between 1 and 512.

When the display shows the desired value, press *[ENTER]* to confirm the setting and then *[MODE/ESC]* to proceed to the next menu item. To switch the menu item without changes, press *[MODE/ESC]* or wait a minute.

Make sure the DMX address matches the configuration of your DMX controller. The following table shows the highest possible DMX address for the various modes.

Mode	Highest possible DMX address
11Ch	502
16Ch	497

**Operating mode 'Auto show'**

Repeatedly press *[MODE/ESC]* until the display shows 'NASL'. Use *[UP]* and *[DOWN]* to select one of the preprogrammed shows. Press *[ENTER]* to start operation in the selected operating mode.

Display with opened menu	Display after confirmation with <i>[ENTER]</i>	Operating mode
NASL	' <i>SLoU</i> '	Automatic show type 1 (slow), in stand alone operation or as master in master / slave operation
NAFA	' <i>FASt</i> '	Automatic show type 2 (fast), in stand alone operation or as master in master / slave operation
NSt5	' <i>SrUn</i> '	Sound-controlled show in stand alone operation or as master in master / slave operation

Display with opened menu	Display after confirmation with <i>[ENTER]</i>	Operating mode
NStc	'crUn'	Automatic show type 3 (mid speed), in stand alone operation or as master in master / slave operation
SLAv	'Son'	Unit operates as slave und follows the master device

## Pan inversion 1

Repeatedly press *[MODE/ESC]* until the display shows 'PAN'. Now use *[UP]* and *[DOWN]* to toggle between 'rPAN' (inverse direction of rotation) and 'PAN' (normal direction of rotation). This setting refers to the rotation of that axis that connects the unit base and the rotatable arm.

When the display shows the desired value, press *[ENTER]* to confirm the setting and then *[MODE/ESC]* to proceed to the next menu item. To switch the menu item without changes, press *[MODE/ESC]* or wait a minute.



**Tilt inversion**

Repeatedly press *[MODE/ESC]* until the display shows 'tit'. Use *[UP]* and *[DOWN]* to select between 'rtit' (inverse direction of inclination) and 'tit' (normal direction of inclination). This setting refers to the rotation of the axis between the two parts of the rotating arm.

When the display shows the desired value, press *[ENTER]* to confirm the setting and then *[MODE/ESC]* to proceed to the next menu item. To switch the menu item without changes, press *[MODE/ESC]* or wait a minute.

**Pan inversion 2**

Repeatedly press *[MODE/ESC]* until the display shows 'tHd'. Use *[UP]* and *[DOWN]* to select between 'rtHd' (inverse direction of rotation) and 'tHd' (normal direction of rotation). This setting refers to the rotation of that axis that connects the rotating arm and the rotating head.

When the display shows the desired value, press *[ENTER]* to confirm the setting and then *[MODE/ESC]* to proceed to the next menu item. To switch the menu item without changes, press *[MODE/ESC]* or wait a minute.

**Display inversion**

Repeatedly press *[MODE/ESC]* until the display shows 'dis'. Use *[UP]* and *[DOWN]* to select between 'rdis' (display text appears upside down) and 'dis' (display text appears normal).

When the display shows the desired value, press *[ENTER]* to confirm the setting and then *[MODE/ESC]* to proceed to the next menu item. To switch the menu item without changes, press *[MODE/ESC]* or wait a minute.

### **Operating mode 'DMX'**

Repeatedly press *[MODE/ESC]* until the display shows '11CH'. Use *[UP]* and *[DOWN]* to select one of the following DMX operating modes: 11 channel or 16 channel. This setting is only relevant if the device is controlled via DMX.

When the display shows the desired value, press *[ENTER]* to confirm the setting and then *[MODE/ESC]* to proceed to the next menu item. To switch the menu item without changes, press *[MODE/ESC]* or wait a minute.

### **Pan range 1**

Repeatedly press *[MODE/ESC]* until the display shows 'PA54'. Use *[UP]* and *[DOWN]* to determine the Pan range. Choose between 'PA54' (Pan range = 540°), 'PA36' (Pan range = 360°) and 'PA18' (Pan range = 180°). This setting refers to the rotation of that axis that connects the unit base and the rotating arm.

When the display shows the desired value, press *[ENTER]* to confirm the setting and then *[MODE/ESC]* to proceed to the next menu item. To switch the menu item without changes, press *[MODE/ESC]* or wait a minute.

**Tilt range**

Repeatedly press *[MODE/ESC]* until the display shows 'ti27'. Use *[UP]* and *[DOWN]* to determine the Tilt range. Choose between 'ti54' (Tilt range = 540°), 'ti36' (Tilt range = 360°) and 'ti18' (Tilt range = 180°). This setting refers to the rotation of the axis between the two parts of the rotating arm.

When the display shows the desired value, press *[ENTER]* to confirm the setting and then *[MODE/ESC]* to proceed to the next menu item. To switch the menu item without changes, press *[MODE/ESC]* or wait a minute.

**Pan range 2**

Repeatedly press *[MODE/ESC]* until the display shows 'tH54'. Use *[UP]* and *[DOWN]* to determine the Pan range. Choose between 'tH54' (Pan range = 540°), 'tH36' (Pan range = 360°) and 'tH18' (Pan range = 180°). This setting refers to the rotation of that axis that connects the rotating arm and the rotating head.

When the display shows the desired value, press *[ENTER]* to confirm the setting and then *[MODE/ESC]* to proceed to the next menu item. To switch the menu item without changes, press *[MODE/ESC]* or wait a minute.

**System reset**

Repeatedly press *[MODE/ESC]* until the display shows 'rEst'. Press *[ENTER]* to reset the servomotors for the axes of movement, the Gobo wheel and the Colour wheel to their home position (mechanical reset).

### **Loading default values**

Repeatedly press *[MODE/ESC]* until the display shows 'LoAd'. Press *[ENTER]* to reset all values that can be adjusted in the main menu to factory defaults.

Overview (main menu)

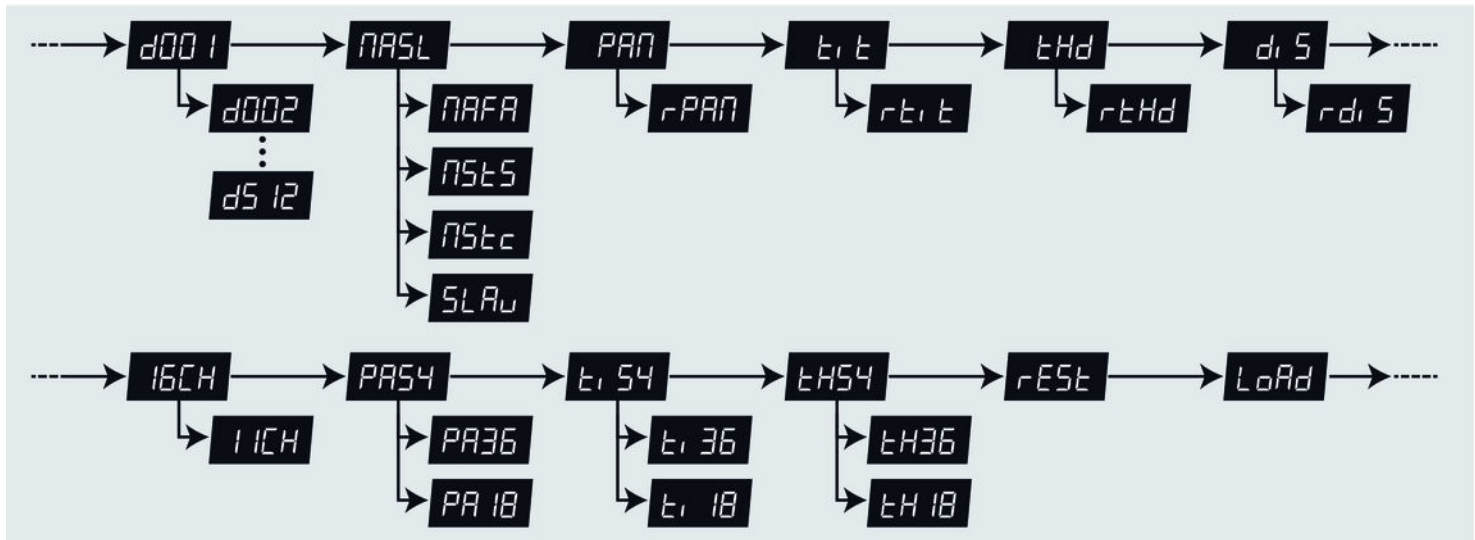

## 7.3 Settings menu

Press *[MODE/ESC]* for about five seconds to activate the settings menu. Use *[UP]* or *[DOWN]* to input the device password 2323. Then the *[UP]* button will change the number at the cursor position, the *[DOWN]* button moves the cursor to the next digit. Press *[ENTER]* when all digits are entered.

To leave the settings menu and return to the main menu, press *[MODE/ESC]* for about five seconds.

All previous settings are stored, even if you disconnect the device from the mains.



*For those values that can be changed in the settings menu, there is no reset function.*

**Rotation preset (pan 1 offset)**

Activate the settings menu. Repeatedly press *[MODE/ESC]* until the display shows 'Pxxx'. Use the *[UP]* / *[DOWN]* buttons to enter a value between 0 and 255, until the head is in the desired home position. This setting refers to the rotation of that axis that connects the unit base and the rotating arm.

When the display shows the desired value, press *[ENTER]* to confirm the setting and then *[MODE/ESC]* to proceed to the next menu item. To switch the menu item without changes, press *[MODE/ESC]* or wait a minute.

**Inclination preset (tilt offset)**

Activate the settings menu. Repeatedly press *[MODE/ESC]* until the display shows 'txxx'. Use the *[UP]* / *[DOWN]* buttons to enter a value between 0 and 255, until the head is in the desired home position. This setting refers to the rotation of the axis between the two parts of the rotating arm.

When the display shows the desired value, press *[ENTER]* to confirm the setting and then *[MODE/ESC]* to proceed to the next menu item. To switch the menu item without changes, press *[MODE/ESC]* or wait a minute.

### **Rotation preset (pan 2 offset)**

Activate the settings menu. Repeatedly press *[MODE/ESC]* until the display shows 'Hxxx'. Use the *[UP]* / *[DOWN]* buttons to enter a value between 0 and 255, until the head is in the desired home position. This setting refers to the rotation of that axis that connects the rotating arm and the rotating head.

When the display shows the desired value, press *[ENTER]* to confirm the setting and then *[MODE/ESC]* to proceed to the next menu item. To switch the menu item without changes, press *[MODE/ESC]* or wait a minute.

### **Colour wheel preset**

Activate the settings menu. Repeatedly press *[MODE/ESC]* until the display shows 'Cxxx'. Use the *[UP]* / *[DOWN]* buttons to enter a value between 0 and 255, until the Colour wheel is in the desired home position.

When the display shows the desired value, press *[ENTER]* to confirm the setting and then *[MODE/ESC]* to proceed to the next menu item. To switch the menu item without changes, press *[MODE/ESC]* or wait a minute.



## Gobo wheel preset

Activate the settings menu. Repeatedly press *[MODE/ESC]* until the display shows 'Gxxx'. Use the *[UP]* / *[DOWN]* buttons to enter a value between 0 and 255, until the Gobo wheel is in the desired home position.

When the display shows the desired value, press *[ENTER]* to confirm the setting and then *[MODE/ESC]* to proceed to the next menu item. To switch the menu item without changes, press *[MODE/ESC]* or wait a minute.

Overview (settings menu)

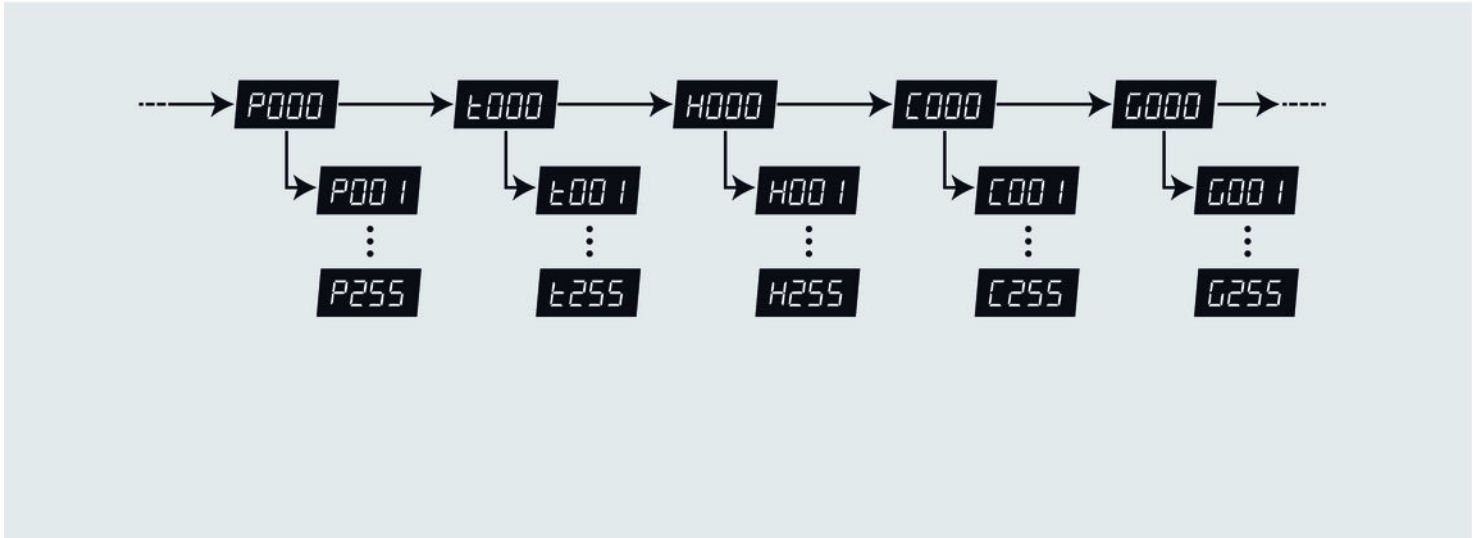

## 7.4 Gobos

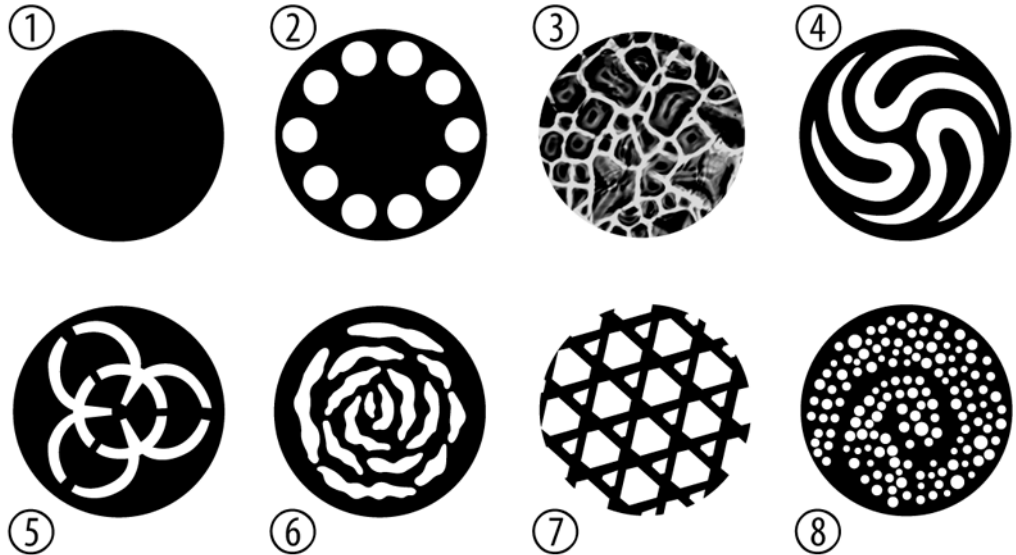

Robohead X-3 LED

## 7.5 Functions in 11-channel DMX mode

Channel	Value	Function
1	0...255	Rotation (pan) around axis 1 (0° up to the maximum value of pan range: 180°, 360° or 540°)
2	0...255	Inclination (tilt) (0° up to the maximum value of Tilt range: 180°, 360° or 540°)
3	0...255	Rotation (pan) around axis 2 (0° up to the maximum value of pan range: 180°, 360° or 540°)
4	Colour wheel	
	0...7	White
	8...15	Dark blue
	16...23	Yellow
	24...31	Pink
	32...39	Green
	40...47	Peachblow
	48...55	Blue

Channel	Value	Function
	56...63	Red
	64...71	White + dark blue
	72...79	Dark blue + yellow
	80...87	Yellow + pink
	88...95	Pink + green
	96...103	Green + peachblow
	104...111	Peachblow + blue
	112...119	Blue + red
	120...127	Red + white
	128...191	Rainbow effect clockwise, increasing speed
	192...255	Rainbow effect counter-clockwise, increasing speed
5	Shutter	
	0...3	Blackout

Channel	Value	Function
	4...7	Open
	8...215	Strobe effect, increasing speed
	216...255	Open
6	Gobo wheel	
	0...7	Open
	8...15	Gobo 2
	16...23	Gobo 3
	24...31	Gobo 4
	32...39	Gobo 5
	40...47	Gobo 6
	48...55	Gobo 7
	56...63	Gobo 8
	64...71	Gobo 8 shake, increasing speed

Channel	Value	Function
	72...79	Gobo 7 shake, increasing speed
	80...87	Gobo 6 shake, increasing speed
	88...95	Gobo 5 shake, increasing speed
	96...103	Gobo 4 shake, increasing speed
	104...111	Gobo 3 shake, increasing speed
	112...119	Gobo 2 shake, increasing speed
	120...127	Open
	128...191	Rainbow effect clockwise, increasing speed
	192...255	Rainbow effect counter-clockwise, increasing speed
7	Gobo rotation	
	0...15	Not in use
	16...127	Rotation clockwise, increasing speed
	128...239	Rotation counter-clockwise, increasing speed

Channel	Value	Function
	240...255	Yo-yo effect (bouncing gobo) with alternating rotation direction, increasing length of rotation intervals
8	Prism	
	0...7	Not in use
	8...255	Prism effect
9	0...255	Focus
10	Special functions	
	0...7	Not in use
	8...15	Blackout during pan-1, pan-2 or tilt movement
	16...23	No blackout during pan-1, pan-2 or tilt movement
	24...31	Blackout during colour wheel movement
	32...39	No blackout during colour wheel movement
	40...47	Blackout during gobo wheel movement



Channel	Value	Function
	48...55	No blackout during gobo wheel movement
	56...87	Not in use
	88...95	Blackout during movement
	96...103	Pan 1, pan 2 and tilt reset
	104...111	Not in use
	112...119	Colour wheel reset
	120...127	Gobo wheel reset
	128...135	Gobo rotation reset
	136...143	Prism reset
	144...151	Focus reset
	152...159	All channel reset
	160...255	Not in use
11	Built-in programmes	

Channel	Value	Function
	0...7	Not in use
	8...23	Programme 1
	24...39	Programme 2
	40...55	Programme 3
	56...71	Programme 4
	72...87	Programme 5
	88...103	Programme 6
	104...119	Programme 7
	120...135	Programme 8
	136...151	Sound-control 1
	152...167	Sound-control 2
	168...183	Sound-control 3
	184...199	Sound-control 4

Channel	Value	Function
	200...215	Sound-control 5
	216...231	Sound-control 6
	232...247	Sound-control 7
	248...255	Sound-control 8

## 7.6 Functions in 16-channel DMX mode

Channel	Value	Function
1	0...255	Rotation (pan) around axis 1 (0° up to the maximum value of pan range: 180°, 360° or 540°)
2	0...255	Inclination (tilt) (0° up to the maximum value of tilt range: 180°, 360° or 540°)
3	0...255	Rotation (pan) around axis 2 (0° up to the maximum value of pan range: 180°, 360° or 540°)
4	0...255	Fine tuning of rotation (pan) around axis 1

Channel	Value	Function
5	0...255	Fine tuning of inclination (tilt)
6	0...255	Fine tuning of rotation (pan) around axis 2
7	0...255	Speed of pan-1, pan-2 and tilt movement
8	Colour wheel	
	0...7	White
	8...15	Dark blue
	16...23	Yellow
	24...31	Pink
	32...39	Green
	40...47	Peachblow
	48...55	Blue
	56...63	Red
	64...71	White + dark blue

Channel	Value	Function
	72...79	Dark blue + yellow
	80...87	Yellow + pink
	88...95	Pink + green
	96...103	Green + peachblow
	104...111	Peachblow + blue
	112...119	Blue + red
	120...127	Red + white
	128...191	Rainbow effect clockwise, increasing speed
	192...255	Rainbow effect counter-clockwise, increasing speed
9	Shutter	
	0...3	Blackout
	4...7	Open
	8...215	Strobe effect, increasing speed

Channel	Value	Function
	216...255	Open
10	0...255	Dimmer (0 to 100 %)
11	Gobo-Rad	
	0...7	Open
	8...15	Gobo 2
	16...23	Gobo 3
	24...31	Gobo 4
	32...39	Gobo 5
	40...47	Gobo 6
	48...55	Gobo 7
	56...63	Gobo 8
	64...71	Gobo 8 shake, increasing speed
	72...79	Gobo 7 shake, increasing speed

Channel	Value	Function
	80...87	Gobo 6 shake, increasing speed
	88...95	Gobo 5 shake, increasing speed
	96...103	Gobo 4 shake, increasing speed
	104...111	Gobo 3 shake, increasing speed
	112...119	Gobo 2 shake, increasing speed
	120...127	Open
	128...191	Rainbow effect clockwise, increasing speed
	192...255	Rainbow effect counter-clockwise, increasing speed
12	Gobo rotation	
	0...15	Not in use
	16...127	Rotation clockwise, increasing speed
	128...239	Rotation counter-clockwise, increasing speed

Channel	Value	Function
	240...255	Yo-yo effect (bouncing gobo) with alternating rotation direction, increasing length of rotation intervals
13	Special functions	
	0...7	Not in use
	8...15	Blackout during pan-1, pan-2 or tilt movement
	16...23	No blackout during pan-1-, pan-2- or tilt movement
	24...31	Blackout during colour wheel movement
	32...39	No blackout during colour wheel movement
	40...47	Blackout during gobo wheel movement
	48...55	No blackout during gobo wheel movement
	56...87	Not in use
	88...95	Blackout during movement
	96...103	Pan 1, pan 2 and tilt reset



Channel	Value	Function
	104...111	Not in use
	112...119	Colour wheel reset
	120...127	Gobo wheel reset
	128...135	Gobo rotation reset
	136...143	Prism reset
	144...151	Focus reset
	152...159	All channel reset
	160...255	Not in use
14	Built-in programmes	
	0...7	Not in use
	8...23	Programme 1
	24...39	Programme 2
	40...55	Programme 3

Channel	Value	Function
	56...71	Programme 4
	72...87	Programme 5
	88...103	Programme 6
	104...119	Programme 7
	120...135	Programme 8
	136...151	Sound-control 1
	152...167	Sound-control 2
	168...183	Sound-control 3
	184...199	Sound-control 4
	200...215	Sound-control 5
	216...231	Sound-control 6
	232...247	Sound-control 7
	248...255	Sound-control 8

---

Channel	Value	Function
15	Prism	
	0...7	Not in use
	8...255	Prism effect
16	0...255	Focus

## 8 Cleaning

### Optical lenses

Clean the exterior of accessible optical lenses periodically to optimise light output. The frequency of cleaning depends on the operating environment: wet, smoky or particularly dirty surroundings can cause more accumulation of dirt on the optics of the device.

- Clean with a soft cloth using normal glass cleaning products.
- Always dry the parts carefully.

## 9 Troubleshooting



### **NOTICE!**

#### **Possible data transmission errors**

For error-free operation make use of dedicated DMX cables and do not use ordinary microphone cables.

Never connect the DMX output to audio devices such as mixers or amplifiers.

In the following we list a few common problems that may occur during operation. We give you some suggestions for easy troubleshooting:

Symptom	Remedy
The unit does not work, no light, the fan does not run	Check the mains power connection and the main fuse.
No response to the DMX controller	<ol style="list-style-type: none"><li>1. The DMX indicator should light up. If it doesn't, check DMX connectors and cables for proper connection.</li><li>2. If the DMX indicator lights up but with no response, check the address settings and DMX polarity.</li><li>3. Try using another DMX controller.</li><li>4. Check whether the DMX cables lie near or adjacent to high voltage cables, which could cause damage or interference with a DMX interface circuit.</li></ol>

If the procedures recommended above do not succeed, please contact our Service Center. You can find the contact information at [www.thomann.de](http://www.thomann.de).

## 10 Technical specifications

Number of DMX channels	11, 16
LED	50 W
Operating voltage supply	AC 230 V ~ , 50 Hz
Power consumption	145 W
Fuse	5 mm × 20 mm, 2 A, 250 V, fast acting
Dimensions (W × D × H)	276 mm × 427 mm × 255 mm
Weight	8.3 kg

## 11 Protecting the environment

### Disposal of the packaging material



For the transport and protective packaging, environmentally friendly materials have been chosen that can be supplied to normal recycling.

Ensure that plastic bags, packaging, etc. are properly disposed of.

Do not just dispose of these materials with your normal household waste, but make sure that they are collected for recycling. Please follow the notes and markings on the packaging.

### Disposal of your old device



This device is subject to the European directive 2002/96/EC.

Do not dispose of the device with your normal household waste.

Dispose of this device through an approved waste disposal firm or through your local waste facility. When discarding the device, comply with the rules and regulations that apply in your country. If in doubt, consult your local waste disposal facility.



Robohead X-3 LED





