

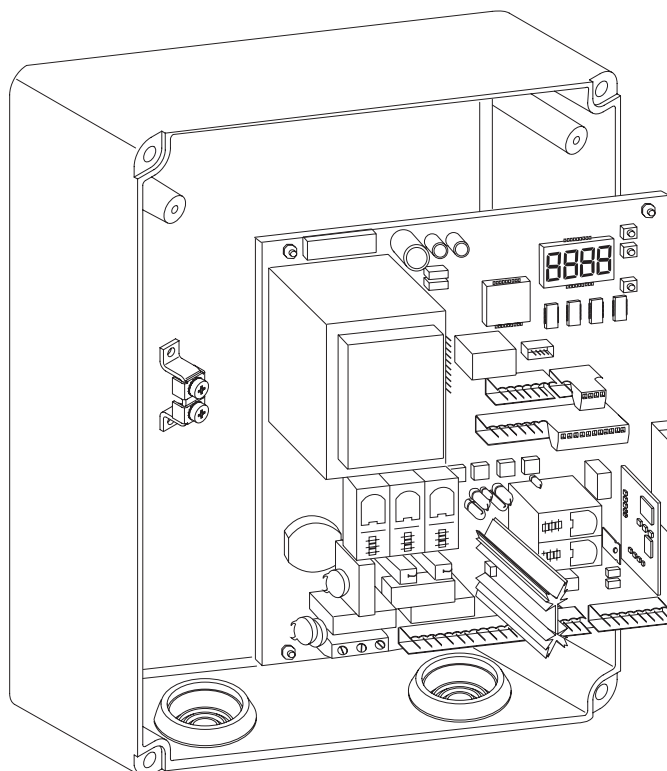

- I** CENTRALINA UNIVERSALE PER IL CONTROLLO DI UNO O DUE MOTORI  
**GB** UNIVERSAL CONTROL UNIT FOR OPERATING ONE OR TWO MOTORS  
**F** UNITE DE COMMANDE UNIVERSELLE POUR LE CONTROLE D'UN OU DEUX MOTEURS  
**D** UNIVERSALSTEUERUNG FÜR EINEN ODER ZWEI MOTOREN  
**E** CENTRAL UNIVERSAL PARA EL CONTROL DE UNO O DOS MOTORES  
**P** CENTRAL UNIVERSAL PARA O CONTROLO DE UM OU DOIS MOTORES



# RIGEL 5



**ISTRUZIONI D'USO E DI INSTALLAZIONE**  
**INSTALLATION AND USER'S MANUAL**  
**INSTRUCTIONS D'UTILISATION ET D'INSTALLATION**  
**INSTALLATIONS-UND GEBRAUCHSANLEITUNG**  
**INSTRUCCIONES DE USO Y DE INSTALACION**  
**INSTRUÇÕES DE USO E DE INSTALAÇÃO**



**AZIENDA CON SISTEMA  
 DI GESTIONE INTEGRATO  
 CERTIFICATO DA DNV  
 = UNI EN ISO 9001:2000 =  
 UNI EN ISO 14001:1996**

Via Lago di Vico, 44  
 36015 Schio (VI)  
 Tel.naz. 0445 696511  
 Tel.int. +39 0445 696533  
 Fax 0445 696522  
 Internet: [www.bft.it](http://www.bft.it)  
 E-mail: [sales@bft.it](mailto:sales@bft.it)

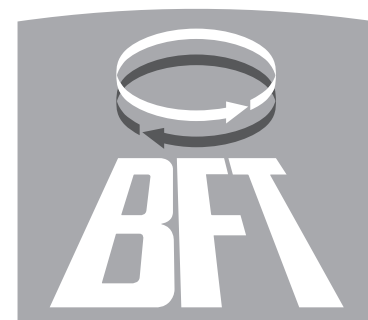

**DICHIARAZIONE DI CONFORMITÀ / DECLARATION OF CONFORMITY / DÉCLARATION DE CONFORMITÉ  
KONFORMITÄTSEKTLÄRUNG / DECLARACION DE CONFORMIDAD / DECLARAÇÃO DE CONFORMIDADE**

Fabbricante / Manufacturer / Fabricant / Hersteller / Fabricante / Fabricante:

BFT S.p.a.

Indirizzo / Address / Adresse / Adresse / Dirección / Endereço:

Via Lago di Vico 44  
36015 - Schio  
VICENZA - ITALY

- Dichiaro sotto la propria responsabilità che il prodotto: / Declares under its own responsibility that the following product:  
/Déclare sous sa propre responsabilité que le produit: / Erklärt auf eigene Verantwortung, daß das Produkt: /Declara, bajo su propia responsabilidad, que el producto: / Declara, sob a sua responsabilidade, que o produto:

Centralina di comando mod./ Control unit mod./ Unité de commande mod./ Steuerzentrale mod./ Central de mando mod./ Central do mando mod./

## RIGEL 5

- È conforme ai requisiti essenziali di sicurezza delle Direttive: / It complies with the main safety requirements of the following Directives: / Est conforme aux exigences essentielles de sécurité des Directives: / Es entspricht den grundlegenden Sicherheitsbedingungen der Direktiven: / Es conforme a los requisitos esenciales de seguridad de las Directivas: / Está conforme aos requisitos essenciais de segurança das Directivas:

BASSA TENSIONE / LOW VOLTAGE / BASSE TENSION / NIEDERSpannung / BAJA TENSION / BAIXA TENSÃO 73/23/CEE, 93/68/CEE (EN60335-1 ('03)) (e modifiche successive / and subsequent amendments / et modifications successives / und ihren nachfolgende Änderungen / e modificações sucessivas / y modificaciones sucesivas).

COMPATIBILITÀ ELETTROMAGNETICA / ELECTROMAGNETIC COMPATIBILITY / COMPATIBILITÉ ÉLECTROMAGNÉTIQUE / ELEKTROMAGNETISCHE KOMPATIBILITÄT / COMPATIBILIDAD ELECTROMAGNETICA / COMPATIBILIDADE ELECTROMAGNÉTICA 89/336/CEE, 91/263/CEE, 92/31/CEE, 93/68/CEE (EN61000-6-1, EN61000-6-2, EN61000-6-3, EN61000-6-4, EN55014-1, EN55014-2) (e modifiche successive / and subsequent amendments / et modifications successives / und ihren nachfolgende Änderungen / e modificações sucessivas / y modificaciones sucesivas).

APPARECCHIATURE RADIO / RADIO SETS / INSTALLATIONS RADIO / RADIOAPPARATE / RADIOEQUIPOS / RADIOAPARELHOS 99/5/CEE (ETSI EN 301 489-3 (2000) +ETSI EN 301 489-1 (2000), ETSI EN 300 220-3 (2000)) (e modifiche successive / and subsequent amendments / et modifications successives / und ihren nachfolgende Änderungen / e modificações sucessivas / y modificaciones sucesivas).

DIRETTIVA MACCHINE / MACHINERY DIRECTIVE / DIRECTIVE MACHINES / MASCHINEN-DIREKTIV / DIRECTIVA MAQUINAS / DIRECTIVA MÁQUINAS 98/37/CEE (EN 12453('01), EN 12445 ('01), EN12978 ('03) (e modifiche successive / and subsequent amendments / et modifications successives / und ihren nachfolgende Änderungen / e modificações sucessivas / y modificaciones sucesivas).

SCHIO, 20/07/2005

Il Rappresentante Legale / The legal Representative  
Le Représentant Légal / Der gesetzliche Vertreter  
El Representante Legal / O Representante legal

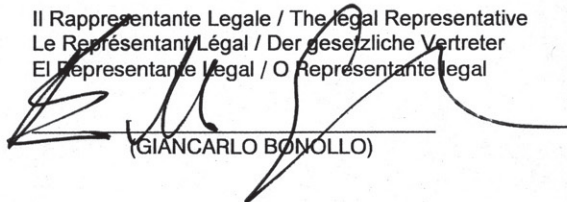

(GIANCARLO BONOLLO)

Nel ringraziarVi per la preferenza accordata a questo prodotto, la ditta è certa che da esso otterrete le prestazioni necessarie al Vostro uso.

Leggete attentamente l'opuscolo "Libretto istruzioni" che lo accompagna in quanto esso fornisce importanti indicazioni riguardanti la sicurezza, l'installazione, l'uso e la manutenzione. Nel ringraziarVi per la preferenza accordata a questo prodotto, la ditta è certa che da esso otterrete le prestazioni necessarie al Vostro uso. Leggete attentamente l'opuscolo "Libretto istruzioni" che lo accompagna in quanto esso fornisce importanti indicazioni riguardanti la sicurezza, l'installazione, l'uso e la manutenzione.

Questo prodotto risponde alle norme riconosciute della tecnica e delle disposizioni relative alla sicurezza. Confermiamo che esso è conforme alle seguenti direttive europee: 73/23/CEE - 93/68/CEE, 89/336/CEE - 91/236/CEE - 92/31/CEE - 93/68/CEE, 98/37/CEE. Per quanto applicabile, essa rispetta le seguenti norme tecniche EN60335-1, EN12453, EN12445.

#### AVVERTENZE

Nelle operazioni di cablaggio ed installazione riferirsi alle norme vigenti e comunque ai principi di buona tecnica.

#### AVVERTENZE

Qualunque intervento sui componenti dell'automazione deve essere eseguito da personale qualificato (installatore).

### 1) GENERALITÀ

La centralina RIGEL 5 viene fornita dal costruttore con settaggio standard. Qualsiasi variazione, deve essere impostata mediante il programmatore UNIPRO o il display integrato. La Centralina supporta completamente il protocollo EELINK.

Le caratteristiche principali sono:

- Controllo di uno o due motori fino a 600W di potenza.
- Regolazione elettronica della coppia.
- Frenatura elettrodinamica regolabile.
- Rallentamento della velocità all'accostamento.
- Ingressi di fine-corsa chiusura / apertura separati per ogni motore.
- Uscita per luce di zona.
- Ingressi separati per le sicurezze.

- Uscita 12V per elettroserratura a scatto o a ventosa.
- Uscita per pilotare un timer.
- Ingresso orologio.
- Connettore per scheda semaforo / preriscaldamento motori.

La scheda è dotata di una morsettiera di tipo estraibile per rendere più agevole la manutenzione o sostituzione. Viene fornita con una serie di ponti precablati per facilitare l'installatore in opera.

### 2) DEMOLIZIONE

**Attenzione: Avvalersi esclusivamente di personale qualificato.**

L'eliminazione dei materiali va fatta rispettando le norme vigenti. Nel caso di demolizione, non esistono particolari pericoli o rischi derivanti dal prodotto stesso. È opportuno, in caso di recupero dei materiali, che vengano separati per tipologia (parti elettriche - rame - alluminio - plastica - ecc.).

### 3) SMANTELLAMENTO

**Attenzione: Avvalersi esclusivamente di personale qualificato.**

Nel caso la centralina venga smontata per essere poi rimontata in altro sito bisogna:

- Togliere l'alimentazione e scollegare tutto l'impianto elettrico.
- Nel caso alcuni componenti non possano essere rimossi o risultino danneggiati, provvedere alla loro sostituzione.

Thank you for buying this product, our company is sure that you will be more than satisfied with its performance. This product is supplied with an "Instruction Manual" which should be read carefully as it provides important information about safety, installation, operation and maintenance.

This product complies with the applicable technical standards and regulations regarding safety. We confirm that it complies with the following European directives: 73/23/CEE - 93/68/CEE, 89/336/CEE - 91/236/CEE - 92/31/CEE - 93/68/CEE, 98/37/CEE. Where applicable, it also complies with technical standards EN60335-1, EN12453, EN12445.

#### IMPORTANT

For the operations of wiring and installation, refer to the regulations in effect and, in any case, to the principles of proper workmanship.

#### IMPORTANT

Any operation on the parts relative to automation must be carried out by qualified personnel (the installer).

### 1) GENERAL OUTLINE

The RIGEL 5 control unit is supplied by the manufacturer with standard setting. Any changes must be set by means of the UNIPRO programmer or the incorporated display.

This Control unit supports the entire EELINK protocol, including the programmer self-supply from the control unit.

These are its main features:

- Control of one or two motors up to 600W power.
- Electronic torque setting.
- Adjustable electrodynamic braking.
- End-of-run speed slow-down.
- Separate opening / closing limit-switch inputs for each motor.
- Output for zone light.
- Separate inputs for safety devices.
- 12V output for click or suction-type electric lock.
- Output for timer piloting.
- Clock input.
- Connector for traffic-light board / motor preheating.

The board is provided with a removable terminal board for easier maintenance and replacement. This is supplied with a series of prewired jumpers to make work easy for the installer.

### 2) SCRAPPING

**Warning: This operation should only be carried out by qualified personnel.** Materials must be disposed of in conformity with the current regulations. In case of scrapping, the automation devices do not entail any particular risks or danger. In case of materials to be recycled, these should be sorted out by type (electrical components, copper, aluminium, plastic etc.).

### 3) DISMANTLING

**Warning: This operation should only be carried out by qualified personnel.** When the control unit is disassembled to be reassembled on another site, proceed as follows:

- Disconnect the power supply and the entire electrical installation.
- In the case where some of the components cannot be removed or are damaged, they must be replaced.



Thank you for buying this product, our company is sure that you will be more than satisfied with its performance.

This product is supplied with an "Instruction Manual" which should be read carefully as it provides important information about safety, installation, operation and maintenance.

This product complies with the applicable technical standards and regulations regarding safety. We confirm that it complies with the following European directives: 73/23/CEE - 93/68/CEE, 89/336/CEE - 91/236/CEE - 92/31/CEE - 93/68/CEE, 98/37/CEE. Where applicable, it also complies with technical standards EN60335-1, EN12453, EN12445.

#### IMPORTANT

For the operations of wiring and installation, refer to the regulations in effect and, in any case, to the principles of proper workmanship.

#### IMPORTANT

Any operation on the parts relative to automation must be carried out by qualified personnel (the installer).

### 1) AUTODIAGNOSTICS

The control unit runs a check on the operating relays and safety mechanisms (photocells, sensor ridge, etc.) before performing opening and closing cycles.

### 2) CONNECTION OF PHOTOCELLS AND SENSOR RIDGE:

By convention, refer to a receiver (Rx-fig.6) with 5 terminals of which terminals 1 and 2 are for the 24V AC power supply, terminal 3 is shared, terminal 4 is the normally closed contact when at rest, terminal 5 is the normally open contact when at rest. The contact is not powered.

### 3) LEGEND

RX: receiver photocells or infrared ridges.

TX: transmitter photocells or infrared ridges.

The transmitters should be connected to terminals 20-44 of RIGEL 5.

The receivers should be connected to terminals 20-21 of RIGEL 5.

- Fig.8 shows connection of RIGEL 5 with no safety device.
- Fig. 9 shows the connection of the RIGEL 5 with 1 tested photocell.
- Fig. 10 shows connection of RIGEL 5 with 1 safety device with verified opening.
- Fig.11 shows connection of RIGEL 5 with 1 safety device with verified closing.
- Fig. 12 shows the connection of the RIGEL 5 with 2 tested photocells
- Fig.13 shows connection of RIGEL 5 with 2 safety devices with verified opening.
- Fig.14 shows connection of RIGEL 5 with 2 safety devices with verified closure.
- Fig.15 shows the connection of the RIGEL 5 with 3 tested photocells
- Fig.16 shows the connection of the RIGEL 5 with 3 tested safety devices on opening.
- Fig.17 shows the connection of the RIGEL 5 with 3 tested safety devices on closing.
- Fig.18 shows the connection of the RIGEL 5 with 2 devices: 1 photocell and 1 tested safety device on opening
- Fig.19 shows the connection of the RIGEL 5 with 3 devices: 1 photocell, 1 safety device on opening and 1 safety device on closing, all being tested.
- Fig.20 shows the connection of the RIGEL 5 with 4 devices: 2 photocells, 1 safety device on opening and 1 safety device on closing, all being tested.
- Fig.21 shows the connection of the RIGEL 5 with 5 devices: 3 photocells, 1 safety device on opening and 1 safety device on closing, all being tested.

### 4) GENERAL SAFETY

**WARNING! An incorrect installation or improper use of the product can cause damage to persons, animals or things.**

- The "Warnings" leaflet and "Instruction booklet" supplied with this product should be read carefully as they provide important information about safety, installation, use and maintenance.
- Scrap packing materials (plastic, cardboard, polystyrene etc) according to the provisions set out by current standards. Keep nylon or polystyrene bags out of children's reach.
- Keep the instructions together with the technical brochure for future reference.
- This product was exclusively designed and manufactured for the use specified in the present documentation. Any other use not specified in this documentation could damage the product and be dangerous.
- The Company declines all responsibility for any consequences resulting from improper use of the product, or use which is different from that expected and specified in the present documentation.
- Do not install the product in explosive atmosphere.
- The construction components of this product must comply with the following European Directives: 89/336/CEE, 73/23/EEC, 98/37/EEC and subsequent amendments. As for all non-EEC countries, the above-mentioned standards as well as the current national standards should be respected in order to achieve a good safety level.

- The Company declines all responsibility for any consequences resulting from failure to observe Good Technical Practice when constructing closing structures (door, gates etc.), as well as from any deformation which might occur during use.
- The installation must comply with the provisions set out by the following European Directives: 89/336/CEE, 73/23/EEC, 98/37/EEC and subsequent amendments.
- Disconnect the electrical power supply before carrying out any work on the installation. Also disconnect any buffer batteries, if fitted.
- Fit an omnipolar or magnetothermal switch on the mains power supply, having a contact opening distance equal to or greater than 3,5 mm.
- Check that a differential switch with a 0.03A threshold is fitted just before the power supply mains.
- Check that earthing is carried out correctly: connect all metal parts for closure (doors, gates etc.) and all system components provided with an earth terminal.
- Fit all the safety devices (photocells, electric edges etc.) which are needed to protect the area from any danger caused by squashing, conveying and shearing.
- Position at least one luminous signal indication device (blinker) where it can be easily seen, and fix a Warning sign to the structure.
- The Company declines all responsibility with respect to the automation safety and correct operation when other manufacturers' components are used.
- Only use original parts for any maintenance or repair operation.
- Do not modify the automation components, unless explicitly authorised by the company.
- Instruct the product user about the control systems provided and the manual opening operation in case of emergency.
- Do not allow persons or children to remain in the automation operation area.
- Keep radio control or other control devices out of children's reach, in order to avoid unintentional automation activation.
- The user must avoid any attempt to carry out work or repair on the automation system, and always request the assistance of qualified personnel.
- Anything which is not expressly provided for in the present instructions, is not allowed.
- Installation must be carried out using the safety devices and controls prescribed by the EN 12978 Standard.

### 5) GENERAL OUTLINE

The **RIGEL 5** control unit is supplied by the manufacturer with standard setting. Any modifications must be entered using the UNIPRO programmer or the incorporated display. This Control unit supports the entire EELINK protocol.

These are its main features:

- Control of one or two motors up to 600W power.
- Electronic torque setting.
- Adjustable electrodynamic braking.
- End-of-run speed slow-down.
- Separate opening / closing limit-switch inputs for each motor.
- Output for zone light.
- Separate inputs for safety devices.
- 12V output for click or suction-type electric lock.
- Output for timer piloting.
- Clock input.
- Connector for traffic-light board / motor preheating.
- Incorporated radio receiver.

The board is provided with a removable terminal board for easier maintenance and replacement. This is supplied with a series of prewired jumpers to make work easy for the installer.

The jumpers relate to the following terminals: 33-34, 35-36, 36-37, 38-39, 39-40, 41-42, 42-43, 52-55. If the above terminals are used, remove the respective jumpers.

### 6) TECHNICAL SPECIFICATIONS

Power supply:	230V±10% 50Hz*
Mains/low voltage insulation:	> 2MΩhm 500Vdc
Dielectric strength:	mains/bty 3750Vac for 1 minute
Motor output current:	3.5A+3.5A max
Motor relay commutation current:	10A
Maximum motor power:	.600W + 600W
Zone/courtesy light:	max 150W
Supply to accessories:	24Vac (1A max absorption)
Electric lock:	12Vdc (0.5A max, 2A for 3 s)
Light/alarm output with free n.o. contact:	max 3A 250Vac
Gate-open warning light:	24Vac 3W max
Blinker:	230V 40W max
Dimensions:	see figure 1
Fuses:	see figure 2

(\* other voltages available on request)

**7) TERMINAL BOARD CONNECTIONS** (Fig.3)

**WARNINGS** - For wiring and installation operations, refer to the current standards and good technical principles.

Wires powered at different voltages must be physically separated, or suitably insulated with at least 1 mm extra insulation. The wires must be clamped by an extra fastener near the terminals, for example by bands.

**WARNING!** For connection to the mains, use a multipolar cable with a minimum of 3x1.5mm<sup>2</sup> cross section and complying with the previously mentioned regulations. For example, if the cable is outside (in the open), it has to be at least equal to H07RN-F, but if it is on the inside (or outside but placed in a plastic cable channel) it has to be or at least equal to H05VV-F with section 3x1.5mm<sup>2</sup>.

**JP1**

- 1 GND terminal.  
2-3 230Vac±10%, 50-60Hz power supply (2 neutral, 3 phase).

**JP2**

- 4-5-6 Motor connection 1 (delayed opening), terminals 5-6 for motor drive, terminal 4 common.

- 5-14 (**JP12**) Motor capacitor connection 1.

- 7-8-9 Motor connection 2 (delayed closing), terminals 8-9 for motor drive, terminal 7 common.

- 8-15 (**JP12**) Motor capacitor connection 2.

**N.B.** If only one motor is used, use motor output 2 and configure logic "1 active motor".

- 10-11 230Vac output for blinker light (40W max) and EBP 230V molelectric lock.

**WARNING!** If the SSR5 auxiliary board is used for motor preheating, move the connection to terminals 12-13 (Fig.3) and refer to Chap. 9.2 Logic Menu --> Blinker output.

- 12-13 230Vac output for zone/courtesy/blinking lights, 150W max. To set the output, refer to paragraph 9.2 Logic Menu ("courtesy light" and "blinking light").

**JP12**

- 14 Motor 1 capacitor connection.

- 15 Motor 2 capacitor connection.

- 16-17 Light/alarm output with free n.o. contact, to pilot stair-light timer or alarm signal for failed gate closure. As a light it commands an impulse (impulse time 1 s) at the start of the operation, as an alarm it lights up if the gate remains open for twice the TCA setting (inhibited by dwell TCA (automatic closing time) logic = 0).

**JP3**

- 18-19 N.O. output (3W max) for 2nd radio channel or for gate-open warning light. This light is off when the gate is closed, flashing on closing and turned on if the gate is opening or already open.

- 20-21 Output 24V ac (1A max) powers accessories and photoreceivers.

- 20-44 Output 24V AC powers phototransmitters.

- 22-23 12Vdc electric lock output, with click (3-second impulse), or suction.

- 24-25 Antenna input for radio receiver board (24 signal, 25 braid).

**JP4**

- 26-27 Internal Start Pushbutton (n.o.). Internal Start command for traffic light.

- 27-28 Start Pushbutton (n.o.). Parallel to radio receiver relay (CH1). External Start command for traffic light.

- 27-29 Pedestrian pushbutton (n.o.). Activation takes place on motor 2; moreover, if the opening cycle has started (not from pedestrian pushbutton), the pedestrian control has the same effect as a Start command.

- 30-31 Open Pushbutton (n.o.).

- 30-32 Close Pushbutton (n.o.).

- 33-34 Lock pushbutton (n.c.). If not used, leave the jumper connected.

- 35-36 Input for ADMAP (dangerous movement area accessible to the public) photocell contact (n.c.). If this is not used, leave the jumper connected.

With ADMAP Photocell Logic = 0: In case of activation before opening, movement is prevented; if activation occurs during opening, movement is stopped and the opening manoeuvre is resumed after release.

With ADMAP Photocell Logic=1: Photocell excluded on opening. The opening movement takes place even when an obstacle is present.

**N.B.** Regardless of the ADMAP Photocell Logic, photocell activation during the closing manoeuvre causes stopping and reopening.

- 36-37 If not used, leave the jumper connected. Input for photocell edge contact on opening SAFE OP (n.c.). In case of activation during opening, the gate is stopped and partly closed. If not used, leave the jumper connected.

- 38-39 Opening limit switch for motor 1 (n.c.). If not used, leave the jumper connected.

- 39-40 Closing limit switch for motor 1 (n.c.). If not used, leave the jumper connected.

- 41-42 Opening limit switch for motor 2 (n.c.). If not used, leave the jumper connected.

- 42-43 Closing limit switch for motor 2 (n.c.). If not used, leave the jumper connected.

**JP5**

- 20(JP3)-44 24V output for transmitters.

- 45-46-47 Connection with tested safety devices (see Fig. from 7 to 21).

- 48-49-50 Connection with tested safety devices (see Fig. from 7 to 21).

**JP6**

- 51-52 Clock input (n.o.). If the connected contact is open (n.o.), the leaves close and get ready for normal operation. If the contact is closed (n.c.), the leaves open and stay open until the contact reopens. **If the opening movement controlled by the TIMER is prevented by the safety devices, gate opening can be resumed by activating the START/OPEN control.**

- 52-55 Input for photocell edge contact on closing SAFE CL (n.c.). In case of activation during closing, the gate is stopped and partly reopened. If not used, leave the jumper connected.

- 53 Photocell test input (PHOT-FAULT).

- 54 Safety edge/opening photocell test input (BAR-FAULT).

- 56 Closing photocell test input (PHOT CL-FAULT).

- JP7** Radio receiver board connector.

- JP8** Serial connection board connector (SCS1).

- JP9** Traffic-light / Preheating SSR5 board connector.

**8) PROGRAMMING**

The control unit is provided with a microprocessor and supplied with operation parameters set by the manufacturer. The predefined parameters can only be changed by means of the UNIPRO programmer.

Before modifying the parameters, carefully read the instructions relating to the UNIPRO programmer, and proceed as described below.

Connect the UNIPRO programmer to the control unit through the UNIFLAT accessory (See fig.5). Enter the "CONTROL UNIT" menu and the "PARAMETERS" submenu, and scroll the display screenfuls using the up/down arrows, then set the numerical values of the parameters listed below.

For the function logics, refer to the "LOGIC" submenu. When using the incorporated programmer for programming, make reference to Fig. A and B and the "Configuration" paragraph. Here is a list of the meanings and values which can be ascribed to each parameter.

**9) CONFIGURATION**

The display programmer is used to set all the RIGEL 5 control panel functions.

The programmer is provided with three pushbuttons for menu scrolling and function parameter configurations (Fig. 2):

+ menu scrolling/value increment key

- menu scrolling/value reduction key

OK Enter (confirm) key

The simultaneous pressure of the + and - keys is used to exit the active menu and move to the preceding menu.

If the + and - keys are pressed simultaneously at the main menu level (parameters, logics, radio, language, autosetting), programming is exited and the display is switched off (The END message will be displayed).

The modifications made are only set if the OK key is subsequently pressed.

When the OK key is pressed for the first time, the programming mode is entered.

The following pieces of information appear on the display at first:

- Display Software version
- Control unit Software version
- Number of total manoeuvres carried out (the value is expressed in hundreds, therefore the display constantly shows 0000 during the first cent manoeuvres).
- Number of manoeuvres carried out since the latest maintenance operation (the value is expressed in cent, therefore the display constantly shows 0000 during the first hundreds manoeuvres).
- Number of memorised radio control devices.

When the OK key is pressed during the initial presentation phase, the first menu (parameters) can be accessed directly.

Here follows a list of the main menus and the respective submenus available.

The predefined parameter is shown between square brackets [ 0 ].

The writing appearing on the display is indicated between round brackets. Refer to Figures A and B for the control unit configuration procedure.

**9.1) Parameter Menu (PR-RF)****1 - Operation time motor 1 (UORH. t. POK. 1) [60s]**

Enter the numerical value corresponding to the working time from 3 to 180 seconds for motor 1.

**1 - Operation time motor 2 (UORH. t. POK. 2) [60s]**

Enter the numerical value corresponding to the working time from 3 to 180 seconds for motor 2.

**2 - Pedestrian operation time (PEd. t.) [6s]**

Set the numerical value of the pedestrian opening time from 3 to 90 seconds.

**3 - Automatic closing time (t.c.R) [40s]**

Set the numerical value of the TCA automatic closing time from 3 to 120 seconds.

**4 - Opening delay time for leaf 1 (oPEN dELAY t iPE) [3s]**

Set the opening delay time for motor 1 with respect to motor 2, which can be adjusted from 1 to 10 seconds.

**5 - Closing delay time for leaf 2 (cL5 dELAY t iPE) [3s]**

Set the closing delay time for motor 2, which can be adjusted from 1 to 60 seconds.

**6 - Slow-down time (SLoW-dOwN t.) [0s]**

Set the end-of-run slow-down time from 0 to 10 seconds. The slow-down time must be subtracted from the working time.

**NOTE:** it is advised to activate timing.

**NOTE:** only use this function when limit switches are fitted.

**7 - Traffic-light area clearance time (cLERR. t) [15s]**

Set the required clearance time for the area involved in the traffic governed by traffic light, from 0 to 30 seconds. Set to 0 if not used.

**8 - %Motor torque (POT. tORQUE) [50%]**

Set the numerical torque value from 1 to 99%.

**9 - %slowdown motor torque (SLoWd tORQUE) [50%]**

(UNIPRO ⇒ Advanced parameters ⇒ address 5)

Set numerically from 1% to 99% the value of motor torque during slowdown time.

**10-%Braking (brAKE) [0%]**

Set the required braking percentage from 0 to 99%, compatibly with the weight of the gate and the existing mechanical stresses.

**11-% Emergency braking (EPER. brAKE) [60%]**

Set the emergency braking numerical value from 0 to 99%; emergency braking is carried out by activating the safety controls available at inputs 34 (Lock), 37 (SAFE OP), and 55 (SAFE CL).

**12-%Preheating (PREHEAT) [30%]**

Set the percentage value of the current from 0 (deactivated pre-heating) to 99% which can be made to pass through the motor windings to keep them at the right temperature.

**13-Zona (ZON) [ 0 ] (UNIPRO ⇒ Advanced parameters ⇒ address 1)**

Enter the zone number between 0 (minimum value) and 127 (maximum value). See paragraph 14 "Serial connection".

**9.2) LOGIC MENU (LoG ic)****- TCA (t.c.R) [ ON ]**

ON: Activates automatic closing

OFF: Excludes automatic closing

**- Opening impulse lock (iBL oPEN) [ OFF ]**

ON: The Start impulse has no effect during the opening phase.

OFF: The Start impulse becomes effective during the opening phase.

**- Impulse lock on closing (iBL cL5E) [OFF]**

ON: The start impulse has no effect during the closing stage.

OFF: The start impulse is effective during the closing stage.

**- Impulse lock TCA (iBL t.c.R) [ OFF ]**

ON: The Start impulse has no effect during the TCA dwell period.

OFF: The Start impulse becomes effective during the TCA dwell period.

**- Ram blow on opening (rRP bLoW c.c.L) [OFF]**

ON: It pushes for approx. 2 seconds in closing direction before opening. This allows the electric lock to be released more easily (not affected by limit switches).

OFF: Excludes the ram blow in closing.

**IMPORTANT** - When no adequate mechanical backstops are installed, do not use this function. It is also to be absolutely avoided in the automation of sliding gates.

**- Ram blow in closing (rRP bLoW c.c.L) [OFF]**

ON: Before carrying out the closing manoeuvre, the gate pushes for about 2 seconds on opening. This allows the electric lock to be released more easily.(not affected by limit switches)

**IMPORTANT** - When no adequate mechanical backstops are installed, do not use this function. It is also to be absolutely avoided in the automation of sliding gates.

OFF: Excludes the ram blow in closing.

**- 2-step, 4-step logic (2 StEP) [OFF]**

ON: Enables 2-step logic (prevails over "3-step logic"). A start impulse has the following effects:

door closed:.....opens  
on opening:.....closes  
door open:.....closes  
on closing:.....opens  
after stopping:.....opens

OFF: Enables 4-step logic when the 3-step logic is set to OFF. A start impulse has the following effects:

door closed:.....opens  
on opening:.....stops and enters TCA if configured

door open:.....closes  
on closing:.....stops and does not enter TCA (stop)  
after stopping:.....opens

**- 3-step logic (3 StEP) [OFF]**

ON: Enables 3-step logic (with 2 steps=OFF). A start impulse has the following effects:

door closed:.....opens  
on opening:.....stops and enters TCA if configured  
door open:.....closes  
on closing:.....opens  
after stopping:.....opens

OFF: Disables 3-step logic.

**- Safety edge (bRR) [ON]**

ON: Input of terminals 36-37 is active as input for the safety edge.

OFF: Input of terminals 36-37 is active as input for opening photocells.

**- Pre alarm (PRE-RLRRP) [ OFF ]**

ON: The blinker comes on about 3 seconds before the motor starts.

OFF: The blinker comes on at the same time as the motor starts.

**- Hold-to-run (hoLd-tO-rUN) [ OFF ]**

ON: Hold-to-run operation: the manoeuvre continues as long as the command key is kept pressed. It is not possible to use the radio transmitter.

OFF: Impulse operation: one impulse opens the gate if closed, and closes it if open.

**- Photocells on opening (PhoEt. oPEN) [ OFF ]**

ON: In case of obscuring, this excludes photocell operation on opening.

During the closing phase, it immediately reverses the motion.

OFF: In case of obscuring, the photocells are active both on opening and on closing. When a photocell is obscured on closing, it reverses the motion only after the photocell is disengaged.

**- Lock hold (bLoC PER5 tSt) [OFF]**

ON: If the motors remain still in a totally open or closed position for over one hour, they are activated for about 3 seconds in the respective direction. This operation takes place once every hour.

**N.B.:** This function has the purpose of compensating any oil volume decrease in the hydraulic motors, due to a temperature drop during prolonged pauses, for instance at night, or to internal leaks.

**IMPORTANT** - When no adequate mechanical backstops are installed, do not use this function. It is also to be absolutely avoided in the automation of sliding gates.

OFF: Excludes the said function.

**- Time count (t iPE. c.) [OFF]**

ON: The control unit calculates the activation time of each motor, based on the preceding manoeuvres.

OFF: The control unit activates the motors at each manoeuvre for the time set.

**N.B.** Always set the operation time to a slightly higher value than needed to carry out the complete manoeuvre.

**- Rapid closing (FR5t cL5) [ OFF ]**

ON: Closes the gate after photocell disengagement, before waiting for the end of the TCA (automatic closing time) set.

OFF: Command not entered.

**- Clock / Pedestrian (cLoCH PEd) [OFF]**

Input for the connection of an external timer.

ON: The Clock input is only active in Motor 2, for the pedestrian time set.

A start command given during the clock phase carries out complete gate opening and closing, resetting the open pedestrian position.

OFF: The Clock input acts on both motors.

**- Courtesy light (ZON L iGHt) [OFF]**

ON: Zone light. Remains active as long as the manoeuvre lasts.

OFF: Courtesy light. Remains active for 90 seconds after last operation.

**N.B.** These settings cannot be used if the blinker output is set to ON.

**- Blinking output (bL iNH) [OFF]**

Activate this function only when the SSR5 traffic light-preheating board is present.

ON: Set the output at terminals 12-13 ("courtesy light") as blinking output (active only during leaf movement).

**N.B.** Any setting relating to the "courtesy light" function is ignored.

OFF: Keep the output at terminals 12-13 as "courtesy light" or "zone light".  
**WARNING!** It is not possible to use the SSR5 board in motor preheating mode and at the same time have the Zone light/Courtesy Light and Blinker/Electric lock on. In this case, outputs 10-11 cannot be used and outputs 12-13 can only be used for one of the two functions.

**- Light/Alarm (L iGHt-RLRRP) [ON]**

ON: Gate-open alarm output (activated if the gate remains open for twice the TCA time set).

OFF: Stair-light control (the impulse stays on for 1 second).

**- 1 active motor (1 PAt. ON) [OFF]**

ON: Only motor 2 activated (1 leaf).

OFF: Both motors are activated (2 leaves).

**- Type of lock (StEt tON-tYPE) [OFF]**

ON: Suction-type lock.

OFF: Click lock.



**- Master/Slave (M<sub>AS</sub>TER) [ OFF ]***(UNIPRO ⇒ Advanced logics ⇒ address 11)*

ON: The control panel is set as Master in a centralised connection (see Paragraph 14).

OFF: The control panel is set as Slave in a centralised connection (see Paragraph 7).

**- Gate-open or 2nd radio channel warning light (ScR-2ch) [ OFF ]**

ON: The output between terminals 18 and 19 is configured as Gate-open warning light, in this case the 2nd radio channel controls pedestrian opening.

OFF: The output between terminals 18 and 19 is configured as 2nd radio channel.

**- Fixed code (F<sub>IXED CODE</sub>) [ OFF ]***(UNIPRO ⇒ Advanced logics ⇒ address 13)*

ON: The receiver is configured for operation in fixed-code mode, see paragraph on "Radio Transmitter Cloning".

OFF: The receiver is configured for operation in rolling-code mode, see paragraph on "Radio Transmitter Cloning".

**- Radio transmitter programming (r<sub>AD</sub> io P<sub>ROG</sub>) [ ON ]***(UNIPRO ⇒ Advanced logics ⇒ address 15)*

ON: This enables transmitter storage via radio:

1 – First press the hidden key (P1) and then the normal key (T1, T2, T3 or T4) of a transmitter already memorised in standard mode by means of the radio menu.

2 – Within 10s press the hidden key (P1) and the normal key (T1, T2, T3 or T4) of a transmitter to be memorised.

The receiver exits the programming mode after 10s, other new transmitters can be entered before the end of this time.

This mode does not require access to the control panel.

OFF: This disables transmitter storage via radio.

The transmitters can only be memorised using the appropriate Radio menu.

**- Photocell test (t<sub>EST</sub> Phot) [ OFF ]***(UNIPRO ⇒ Advanced logics ⇒ address 13)*

ON: Activates photocell check (see fig. 7 to 14)

OFF: Deactivates photocell check

**- Photocell test on closing (t<sub>EST</sub> Phot cL) [ OFF ]**

ON: Enables the test of the active photocells on closing.

OFF: Disables the test of the active photocells on closing.

**- Electric edge test (t<sub>EST</sub> bRR) [ OFF ]****- Menu visible with safety edge activated only.***UNIPRO ⇒ Advanced logics ⇒ address 14)*

ON: Activates electric edge check (see fig. 7 to 14)

OFF: Deactivates electric edge check

**- Photocell test on opening (t<sub>EST</sub> Phot oP) [ OFF ]****- Menu visibile with safety edge deactivated only.**

ON: Enables the test of the active photocells on opening.

OFF: Disables the test of the active photocells on opening.

**9.3) RADIO MENU (r<sub>AD</sub> io)****- Add (R<sub>dd</sub>)**

Allows you to add one key of a radio control device to the receiver memory; after storage it displays a message showing the receiver number in the memory location (from 01 to 64).

**Add Start button (R<sub>dd</sub> St<sub>ART</sub>)**

associates the required key to Start command

**Add 2ch button (R<sub>dd</sub> 2ch)**

associates the required key to 2nd radio channel

**- Read (r<sub>ERd</sub>)**

Checks one key of a receiver; if stored it displays a message showing the receiver number in the memory location (from 01 to 64), and the key number (T1, T2, T3 or T4).

**- Eliminate list (E<sub>REMOVE</sub> bY)****WARNING!** Completely removes all memorised radio control devices from the receiver memory.**- Receiver code reading (r<sub>H</sub> c<sub>odE</sub>)**

This displays the code entered in the receiver (par.11).

**Consult paragraphs 8/9/10/11 for further information concerning the advanced functions of the Clonix incorporated receiver.****9.4) Language Menu (L<sub>ANGUAGE</sub>)**

Allows you to set the language on the display programmer.

5 languages are available:

- ITALIAN (t<sub>R</sub>)
- FRENCH (F<sub>R</sub>)
- GERMAN (d<sub>E</sub>U)
- ENGLISH (E<sub>NG</sub>)
- SPANISH (E<sub>SP</sub>)

**9.5) MENU DEFAULT (d<sub>E</sub>F<sub>A</sub>U<sub>L</sub>T)**

Restores the preset default values on the control unit.

**9.6) DIAGNOSTICS AND MONITORING**

The display on the RIGEL 5 panel shows some useful information, both during normal operation and in the case of malfunctions.

**Diagnostics:**

In the case of malfunctions, the display shows a message indicating which device needs to be checked:

- STRE = EXTERNAL START input activation
- STRI = INTERNAL START input activation
- PED = input activation PEDESTRIAN
- OPEN = OPEN input activation
- CLS = CLOSE input activation
- STOP = STOP input activation
- PHOT = PHOT input activation
- PHOP = activation of input for PHOTOCELL ON OPENING
- PHCL = activation of input for PHOTOCELL ON CLOSING
- BAR = input activation SAFETY EDGE
- SWC1 = activation of input for MOTOR 1 CLOSING LIMIT SWITCH
- SWO1 = activation of input for MOTOR 1 OPENING LIMIT SWITCH
- SWC2 = activation of input for MOTOR 2 CLOSING LIMIT SWITCH
- SWO2 = activation of input for MOTOR 2 OPENING LIMIT SWITCH
- TIME = TIMER input activation

**! WARNING: Check that the impact force value measured at the points established by the EN 12445 standard is lower than that specified in the EN 12453 standard.**

**! Incorrect sensitivity setting can cause injuries to persons or animals, or damage to things.**

**9.7) STATISTICS**

Having connected the UNIPRO programmer to the control unit, enter the CONTROL UNIT / STATISTICS menu and scroll the screenful showing the statistical parameters:

- Board microprocessor software version.
- Number of cycles carried out. If motors are replaced, count the number of manoeuvres carried out up to that time.
- Number of cycles carried out from the latest maintenance operation. It is automatically set to zero after each self-diagnosis or parameter writing.
- Date of latest maintenance operation. To be updated manually from the appropriate menu "Update maintenance date".
- Installation description. 16 characters can be entered for installation identification.

**10) INTEGRATED RECEIVER TECHNICAL SPECIFICATION**

Receiver output channels:

- output channel 1, if activated, controls a START command.
- output channel 2, if activated, controls the excitation of the 2nd radio channel relay for 1s.

Transmitter versions which can be used:



all Rolling Code transmitters compatible with

**ANTENNA INSTALLATION****Use an antenna tuned to 433MHz.****For Antenna-Receiver connection, use RG8 coaxial cable.**

The presence of metallic masses next to the antenna can interfere with radio reception. In case of insufficient transmitter range, move the antenna to a more suitable position.

**11) RECEIVER CONFIGURATION**

The on-board receiver combines characteristics of utmost safety in copying variable code (rolling code) coding with the convenience of carrying out transmitter "cloning" operations thanks to an exclusive system.

Cloning a transmitter means creating a transmitter which can be automatically included within the list of the transmitters memorised in the receiver, either as an addition or as a replacement of a particular transmitter.

Cloning by replacement is used to create a new transmitter which takes the place of the one previously memorised in the receiver; in this way a specific transmitter can be removed from the memory and will no longer be usable.

Therefore it will be possible to remotely program a large number of additional transmitters or, for example, replacement transmitters for those which have been lost, without making changes directly to the receiver.

When coding safety is not a decisive factor, the on-board receiver allows you to carry out fixed-code additional cloning which, although abandoning the variable code, provides a high number of coding combinations, there-

fore keeping it possible to “copy” any transmitter which has already been programmed.

## PROGRAMMING

Transmitter storage can be carried out in manual mode or by means of the UNIRADIO programmer which allows the complete installation database to be managed through the Eedbase software.

In this second case, receiver programming takes place through the connection of UNIRADIO to the **RIGEL 5** control panel, using the UNIFLAT and UNIDA accessories as indicated in Fig. 4.

## 12) MANUAL PROGRAMMING

In the case of standard installations where advanced functions are not required, you can proceed to manual storage of the transmitters, making reference to fig. B for basic programming.

- If you wish the transmitter to activate output 1 (START) by means of key1, key2, key3 or key4, enter the transmitter in menu “Start key”, as in fig. B.
- If you wish the transmitter to activate output 2 (2nd radio channel relay) by means of key1, key2, key3 or key4, enter the transmitter in menu “2ch ch. key”, as in fig. B.

**Note:** Hidden key P1 appears differently depending on the transmitter model. For transmitters with hidden key, press hidden key P1 (fig. B1). For transmitters without hidden key, the key P1 function corresponds to simultaneously pressing the 4 transmitter keys or, after opening the battery compartment, bridging the two P1 points by means of a screwdriver (fig. B2).

## IMPORTANT NOTE: ATTACH THE ADHESIVE KEY LABEL TO THE FIRST MEMORISED TRANSMITTER (MASTER).

In the case of manual programming, the first transmitter assigns the key code to the receiver; this code is necessary in order to carry out subsequent cloning of the radio transmitters.

## 13) RADIO-TRANSMITTER CLONING

### Rolling-code cloning / Fixed-code cloning

Make reference to the UNIRADIO Instructions and the CLONIX Programming Guide.

### 13.1) ADVANCED PROGRAMMING: COLLECTIVE RECEIVERS

Make reference to the UNIRADIO Instructions and the CLONIX Programming Guide.

## 14) SERIAL CONNECTION USING SCS1 BOARD (Fig.5)

The **RIGEL 5** control panel allows several automation units (SCS1) to be connected in a centralised way by means of appropriate serial inputs and outputs. This makes it possible to use one single command to open and close all the automation units connected.

Following the diagram in Fig.6, proceed to connecting all the **RIGEL 5** control panels, exclusively using a telephone-type line.

Should a telephone cable with more than one pair be needed, it is indispensable to use wires from the same pair.

**The length of the telephone cable between one appliance and the next must not exceed 250 m.**

At this point, each of the **RIGEL 5** control panels must be appropriately configured, by setting a MASTER unit first of all, which will have control over all the others, to be necessarily set as SLAVE (see logic menu).

Also set the Zone number (see parameter menu) between 0 and 127.

The zone number allows you to create groups of automation units, each one answering to the Zone Master unit. **Each zone can only be assigned one Master unit, the Master unit in zone 0 also controls the Slave units in the other zones.**

## 15) SSR5 TRAFFIC-LIGHT / MOTOR PREHEATING BOARD (Fig.4)

When inserted in the appropriate connector, it provides:

- Control of two traffic lights with 2 lights each.
- Preheating of motors for cold climate.

### 15.1) Traffic light layout

Traffic light 1 must be positioned on the outside of the gate and traffic light 2 on the inside (see figure 4).

**WARNINGS** - Place signs for speed limitation to “Walking pace”.

### 15.2) Motor preheating layout

The “S” probe must be positioned and fixed on the outside to detect external temperature. It is to be connected to respective terminals 7-8 on the preheating board.

### 15.3) Configuration

#### A) For the traffic light.

Connect UNIPRO to the RIGEL 5 board and set the following functions to “ON”: “Open. Imp. Lock”, “TCA Imp. Lock”, “2- step logic”, “pre-alarm”.

There are 3 Dip-switches in the SSR5 board.

### Dip-switch 1

ON - Blinking is excluded when movement starts.

OFF - Blinking is activated when movement starts (lasting 5 s).

### Dip-switch 2

ON - With gate closed, switches red lights on.

OFF - Lights off with gate closed.

### B) Motor preheating

Enter a % value greater than 0 (otherwise the pre-heating function will not work) from the “**Parameter functions**” menu to establish the value of the power supply current necessary to keep the motors heated.

### Preheating trimmer.

Regulates the preheating activation temperature. Can be set from +8° to -8°.

## 15.4) SSR5 terminal board connections (Fig.4)

### A) Traffic light.

**JP1** - RIGEL 5 board connector.

### JP2

- |   |                                  |
|---|----------------------------------|
| 1 | phase.                           |
| 2 | red light for traffic light 1.   |
| 3 | red light for traffic light 2.   |
| 4 | green light for traffic light 1. |
| 5 | green light for traffic light 2. |

### B) Motor preheating

### JP3

- |     |  |
|-----|--|
| 6   | Blinker / EBP connection for preheating. |
| 7-8 | Thermal probe connection.                |

## 15.5) RIGEL 5 terminal board connections for traffic light

26-27 Internal START command - causes the gate to open, which is signalled by the red light coming on outside and the green light inside, when the gate is fully open.

27-28 External START command - causes the gate to open, which is signalled by the green light coming on outside when the gate is fully open, and the red light coming on inside.

The external START command must be the only access control available from the outside (already existing on the first radiz receiver channel).

## 15.6) Signal indication LEDs existing in the board (Fig.4)

- |     |   |
|-----|---|
| DL1 | Green LED for traffic light 1 (external). |
| DL3 | Red LED for traffic light 1 (external).   |
| DL2 | Green LED for traffic light 2 (internal). |
| DL4 | Red LED for traffic light 2 (internal).   |

## 15.7) Traffic light signal indication

**Green light:** access allowed.

**Red fixed light :** no access. During the opening and closing manoeuvres, the 2 red lights stay on.

**Red blinking light :** gate starts moving: no access.

**N.B.:** In the case where, during the TCA dwell time or closing phase, the control unit receives a Start command to enable the opposite direction of movement, the control unit starts opening, completes the TCA time and waits for the “**traffic-light area clearance time**” set, keeping the fixed red lights on throughout this entire phase before enabling the green lights requested. Should any obstacle interfere with the photocells during the traffic-light area clearance time, the previously set time will be restored.

## 16) SCRAPPING

**Warning:** This operation should only be carried out by qualified personnel. Materials must be disposed of in conformity with the current regulations. In case of scrapping, the automation devices do not entail any particular risks or danger. In case of materials to be recycled, these should be sorted out by type (electrical components, copper, aluminium, plastic etc.).

## 17) DISMANTLING

**Warning:** This operation should only be carried out by qualified personnel. When the control unit is disassembled to be reassembled on another site, proceed as follows:

- Disconnect the power supply and the entire electrical installation.
- In the case where some of the components cannot be removed or are damaged, they must be replaced.

**The descriptions and illustrations contained in the present manual are not binding. The Company reserves the right to make any alterations deemed appropriate for the technical, manufacturing and commercial improvement of the product, while leaving the essential product features unchanged, at any time and without undertaking to update the present publication.**



Fig. A

ACCESS TO MENUS

Press the OK key  
OK

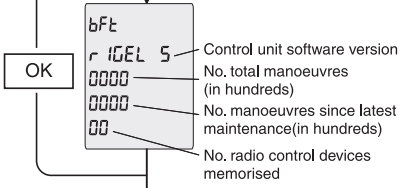

LEGENDA

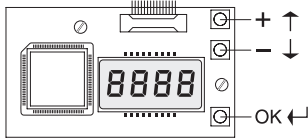

- +/-** Simultaneously press the + and - keys. Simultaneous pressure of the + and - keys allows you to exit the active menu and return to the preceding menu; if this takes place at the main menu level, programming is exited and the display switched off. The modifications made are only confirmed if the OK key is subsequently pressed.
- PrG OK** OK! message (confirms modification made)
- PrG KO** KO! message (value or function error)
- <** "Wait" message (enter value or function)

- [00]** Preset value
- ↑ +/ON** Parameter increment/reduction or ON/OFF commutation
- OK** Press OK key (Enter/confirm)
- ↓ +/↑** Menu scrolling (+ = preceding - = following)

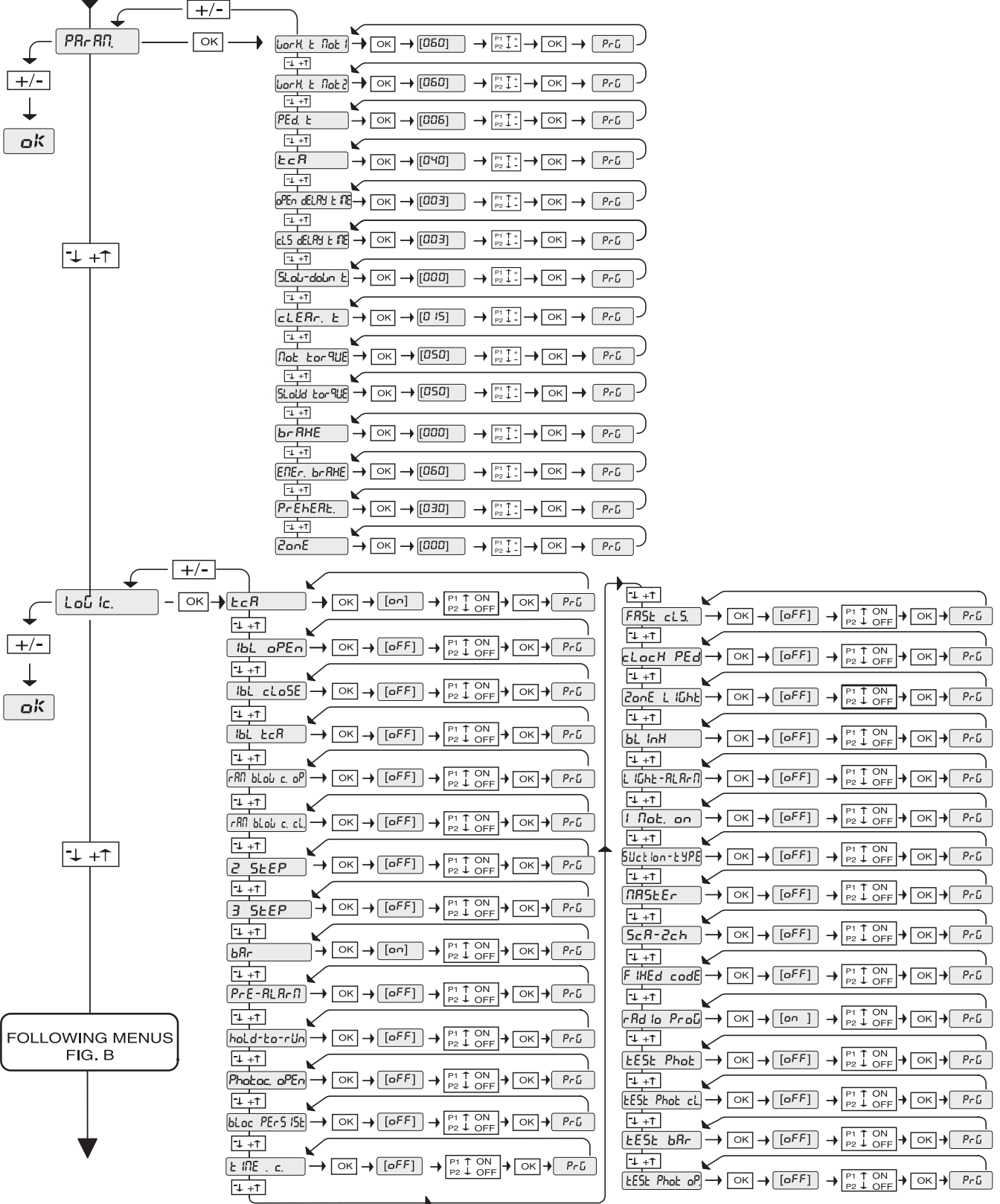

FOLLOWING MENUS  
FIG. B

Fig. 1

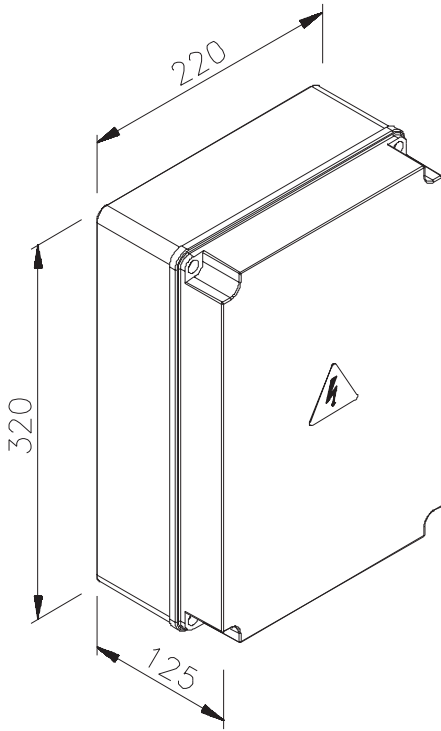

Fig. 2

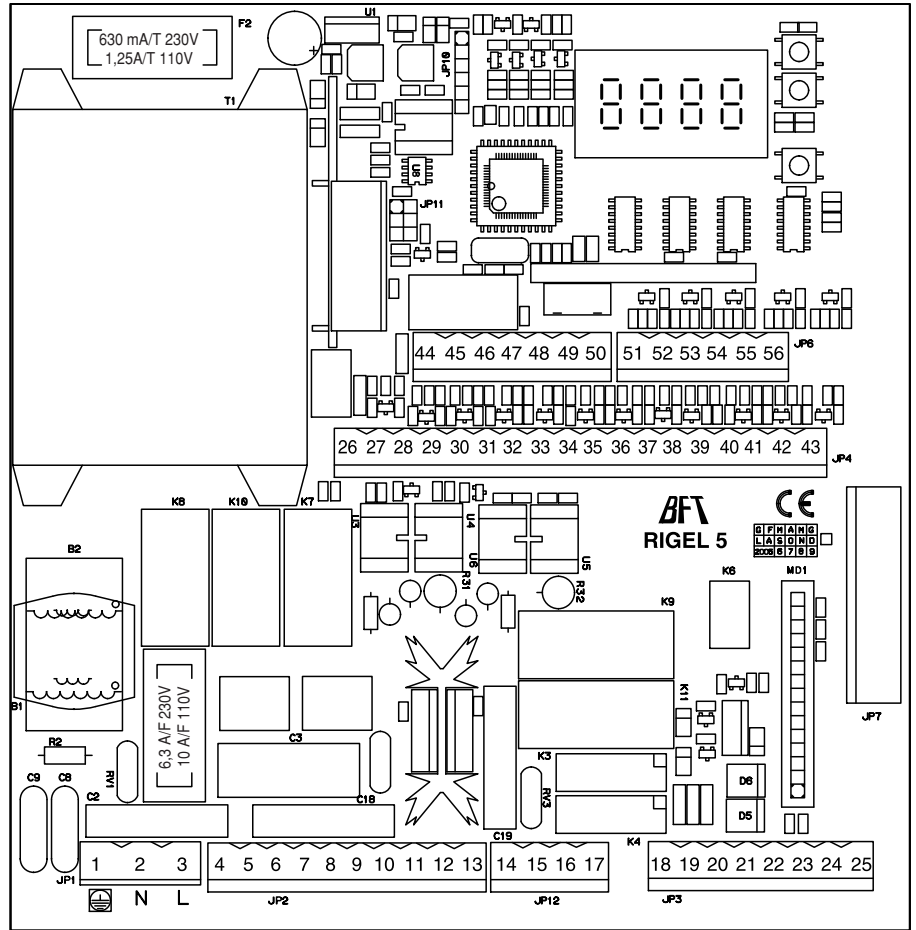

Fig. 3

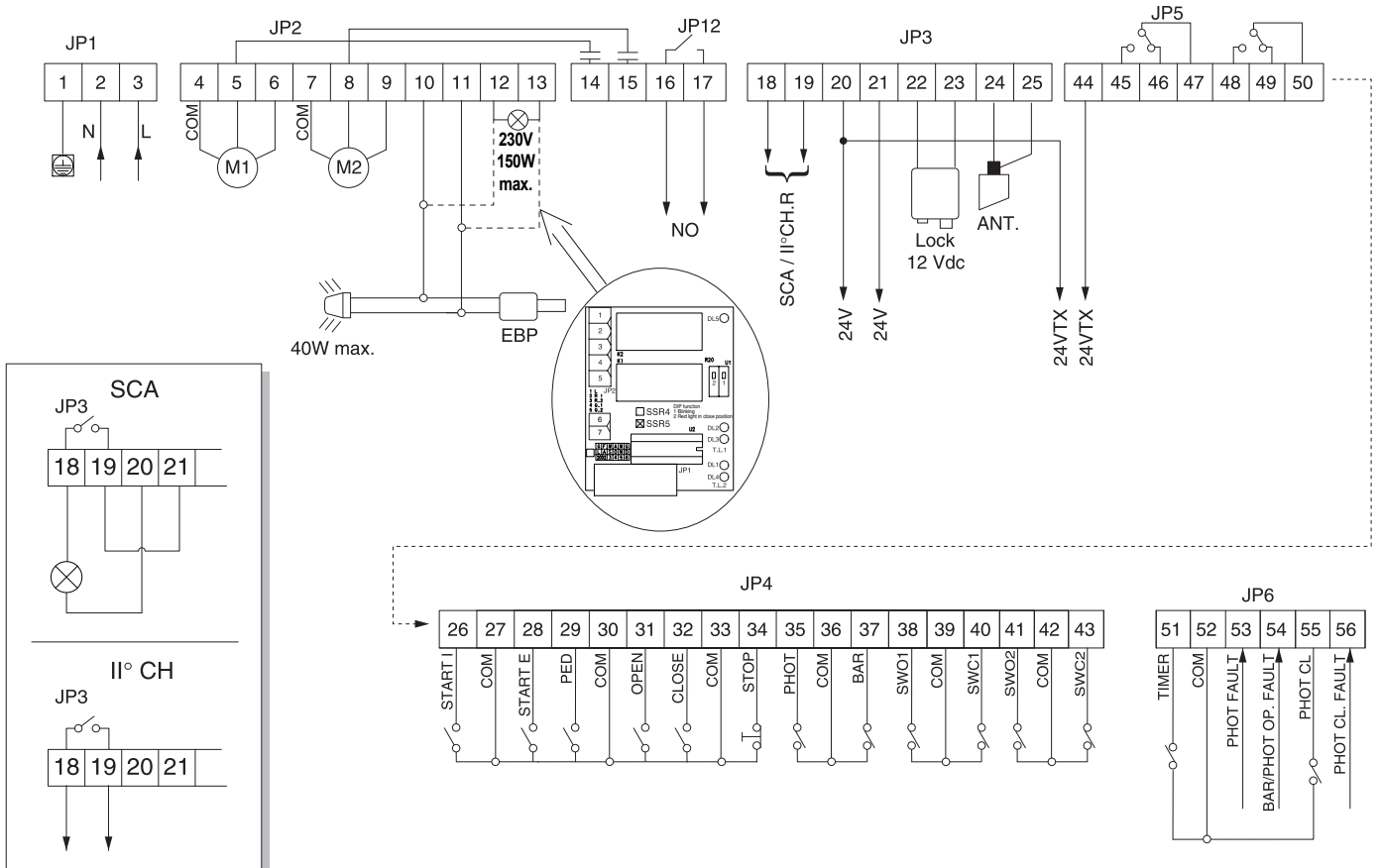
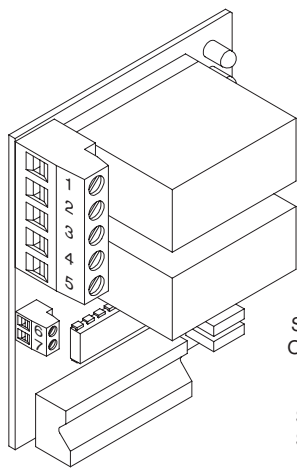

Fig. 4



(R1) (G1)	(R2) (G2)
Semaforo 1 esterno Outside traffic light 1 Feu 1 extérieur Ampel 1 Aussen Semáforo 1 exterior Semáforo 1 externo	Semaforo 2 interno Inside traffic light 2 Feu 2 intérieur Ampel 2 Innen Semáforo 2 interior Semáforo 2 interno

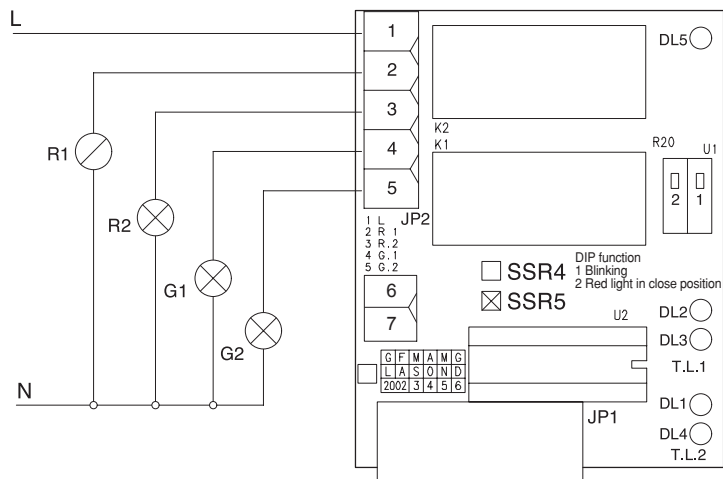
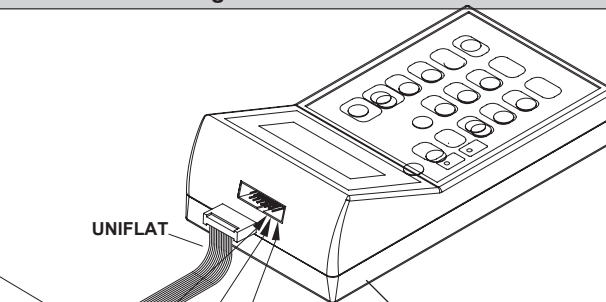
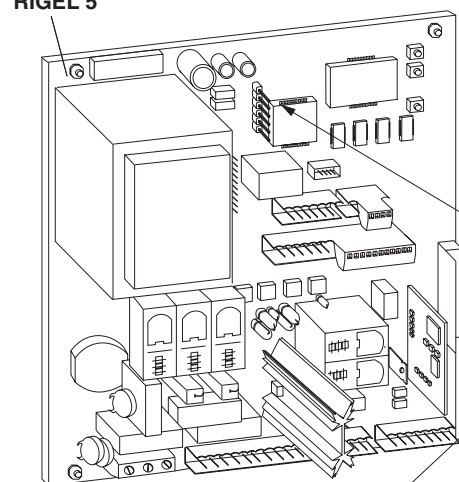

Fig. 5

RIGEL 5



UNIPRO

UNIPOWER

Contatti  
Contacts  
Contactos  
Kontakte  
Contatos

Contatti  
Contacts  
Contactos  
Kontakte  
Contatos

UNITRC

UNIFLAT

UNIMITTO

UNIFLAT

UNITRC

Contatti  
Contacts  
Contactos  
Kontakte  
Contatos

Contatti  
Contacts  
Contactos  
Kontakte  
Contatos

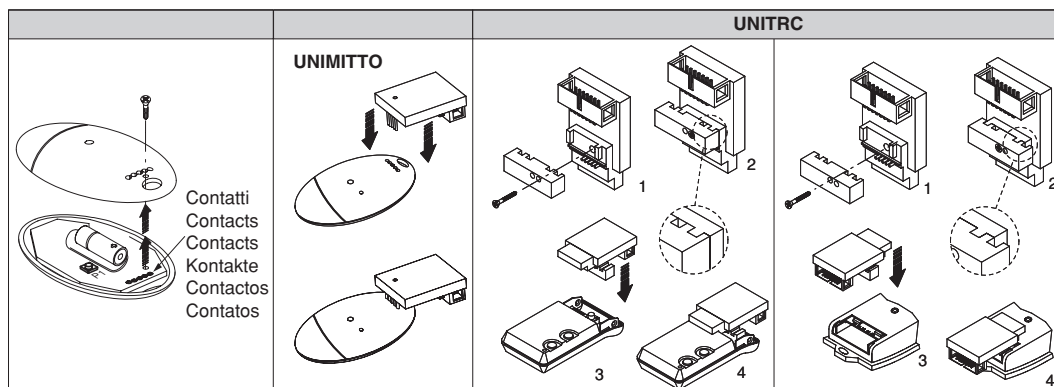
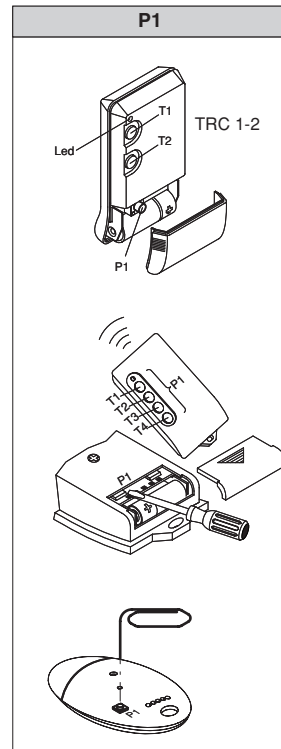



Fig. 6

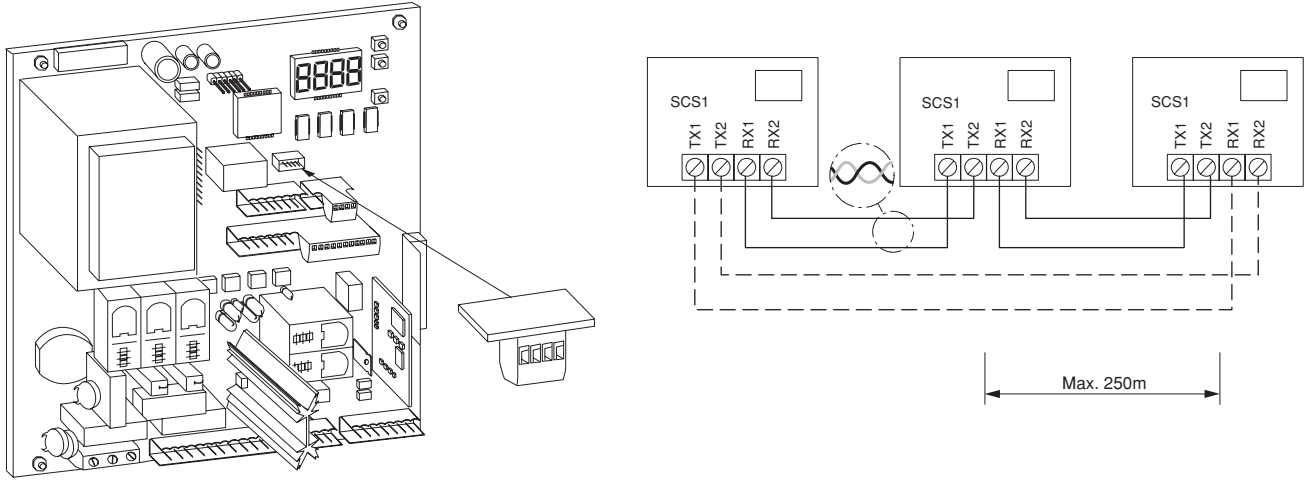

Fig. 7

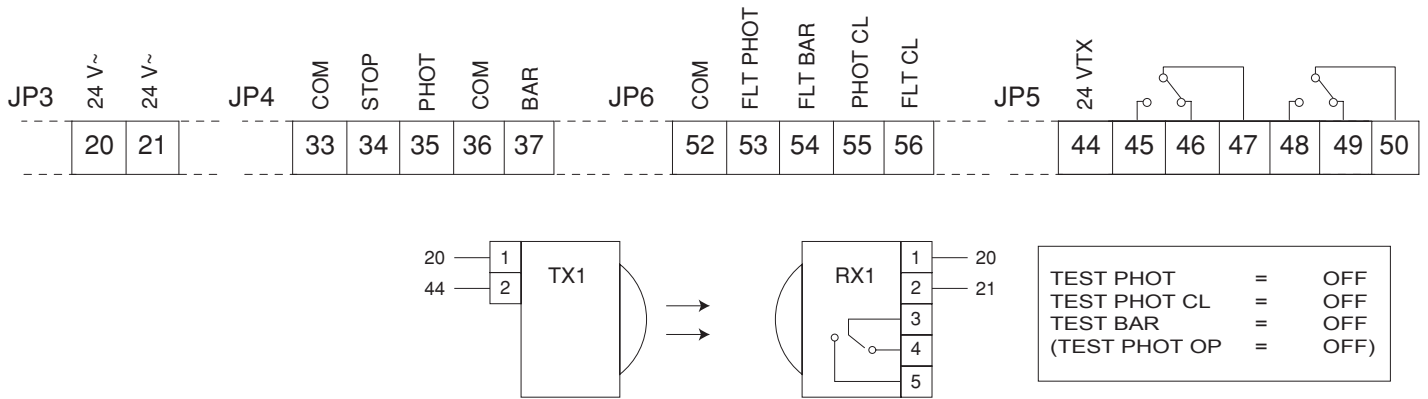

Fig. 8

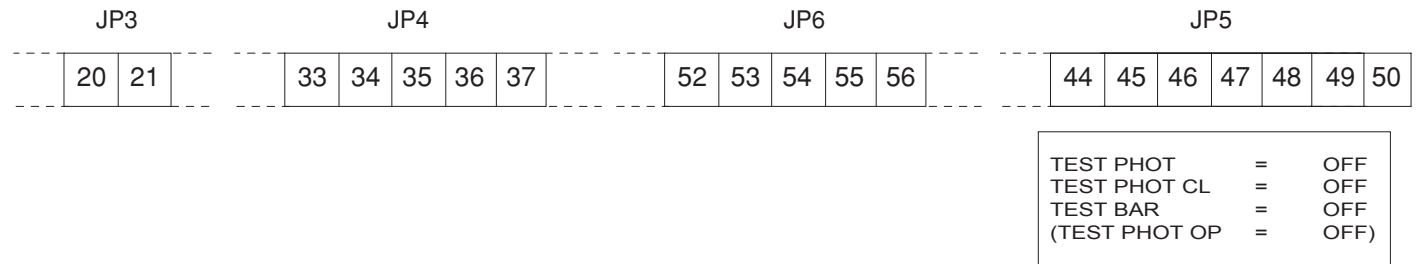
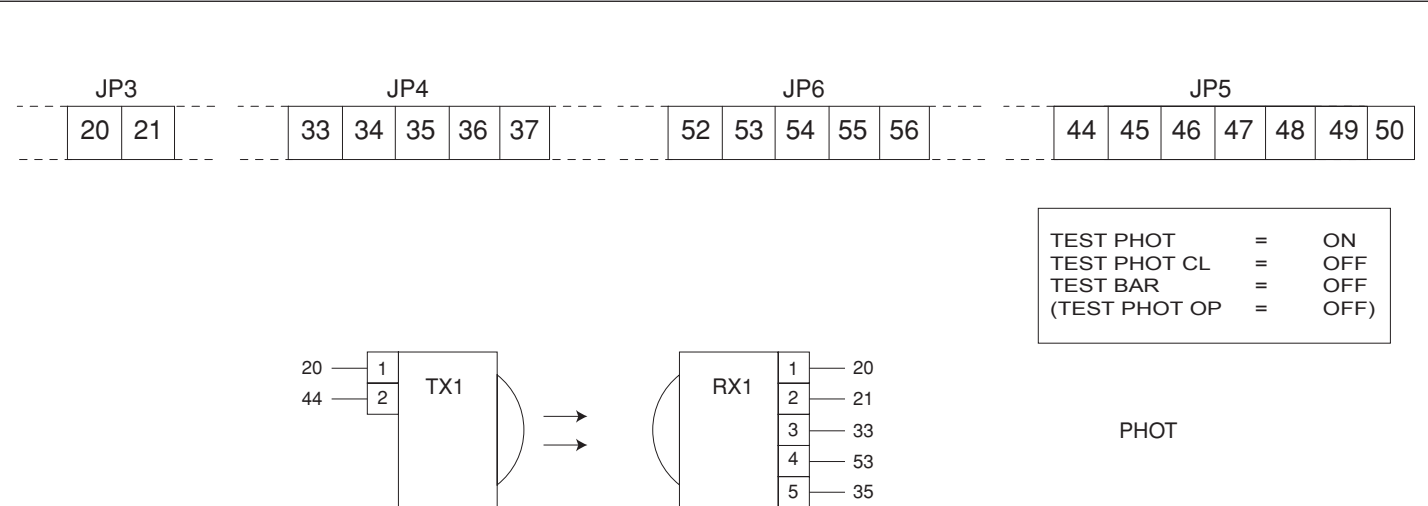
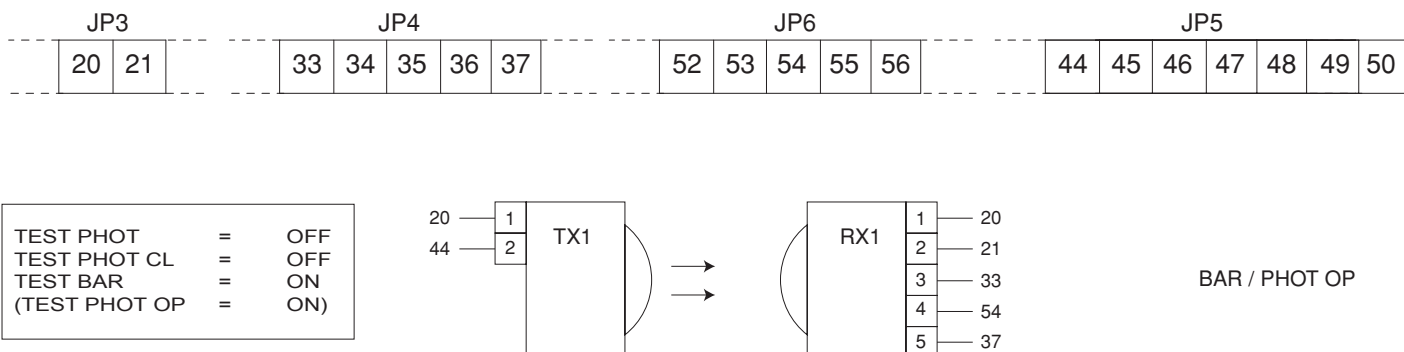

Fig. 9



**Fig. 10**



**Fig. 11**

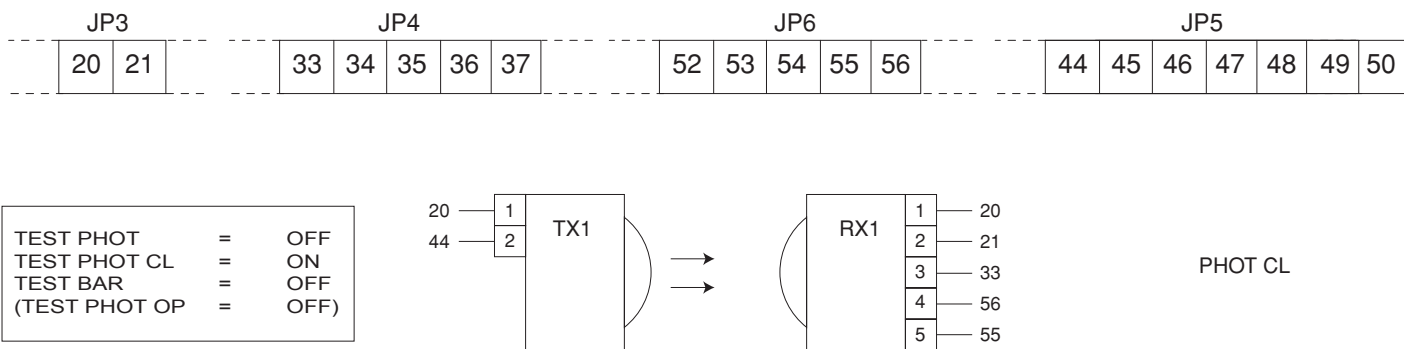

**Fig. 12**

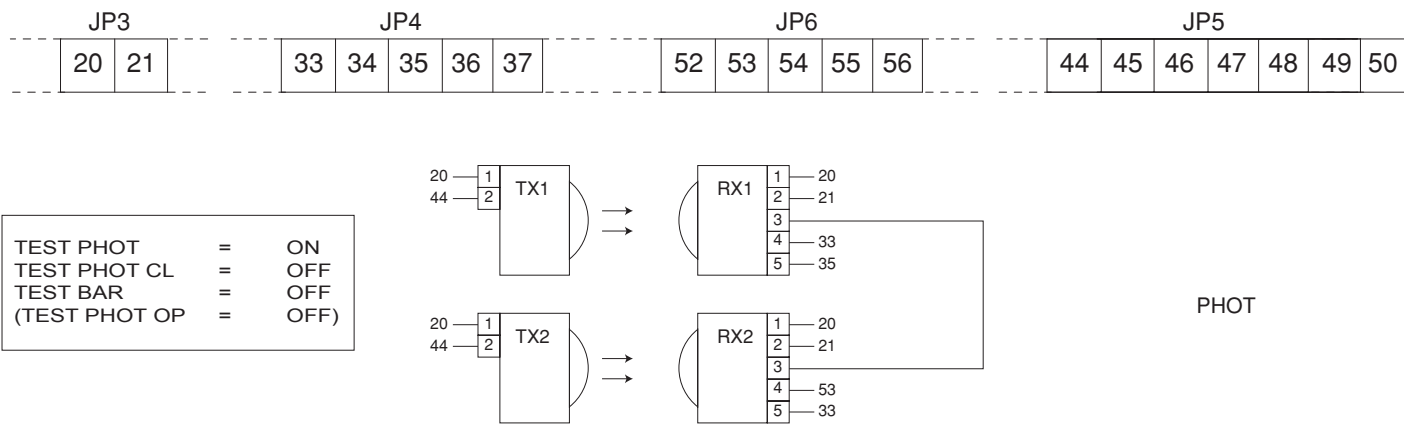

**Fig. 13**

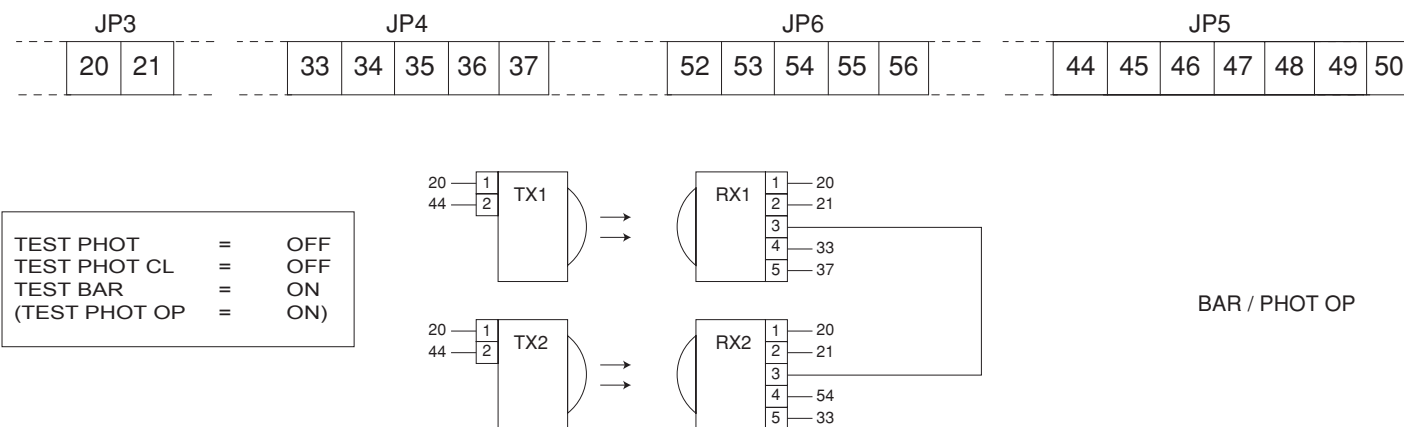

**Fig. 14**

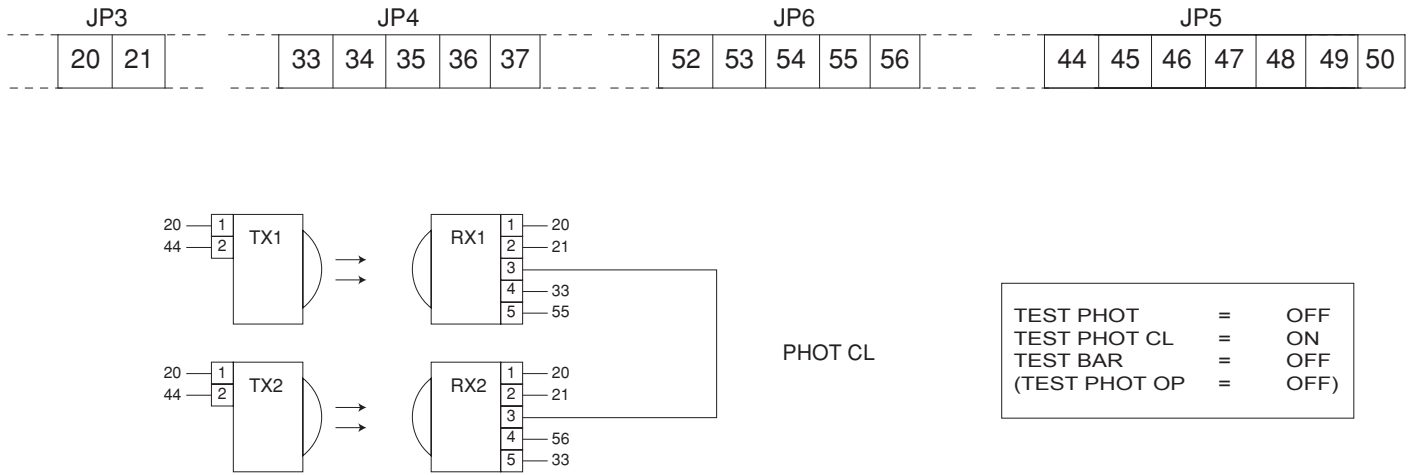

**Fig. 15**

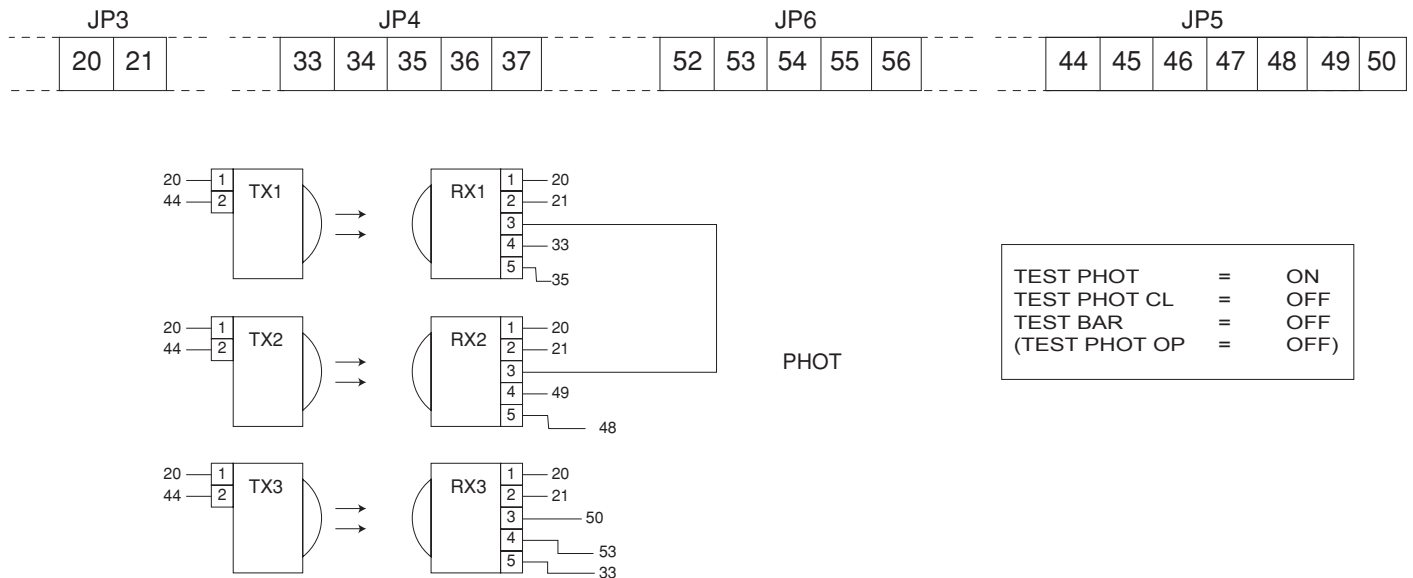

**Fig. 16**

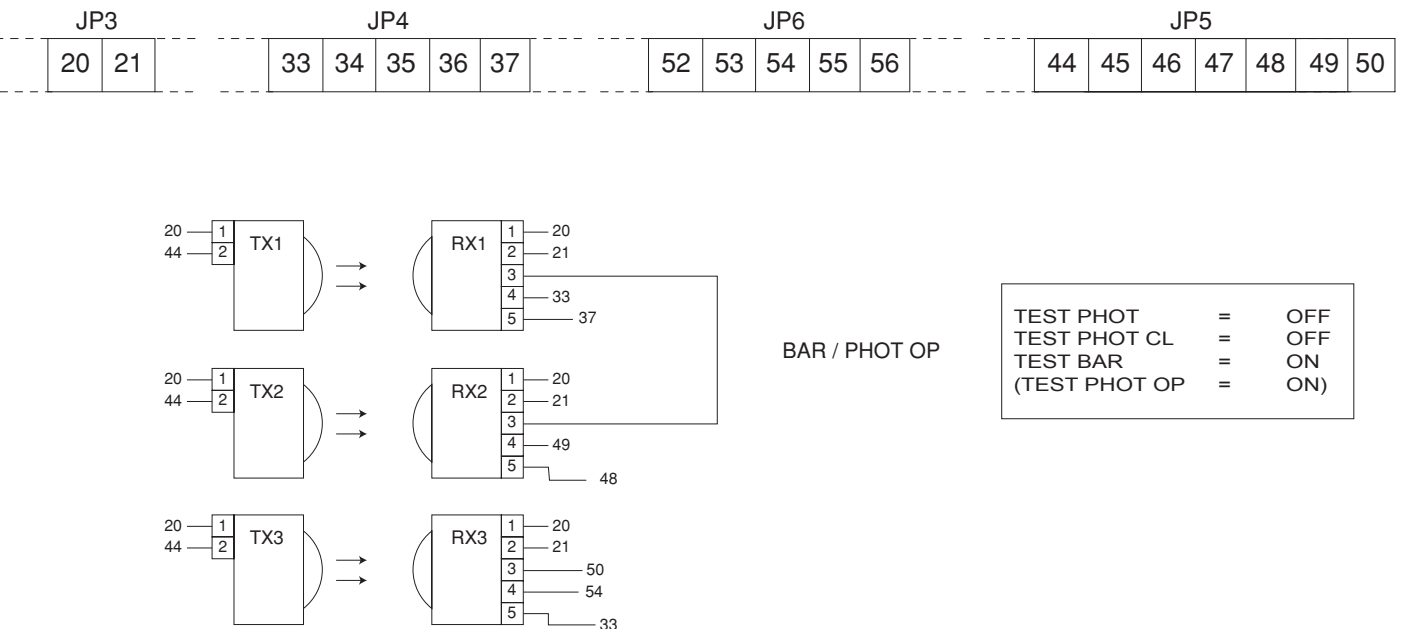
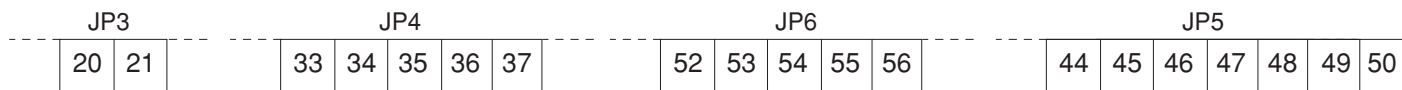



Fig. 17



TEST PHOT = OFF  
 TEST PHOT CL = ON  
 TEST BAR = OFF  
 (TEST PHOT OP = OFF)

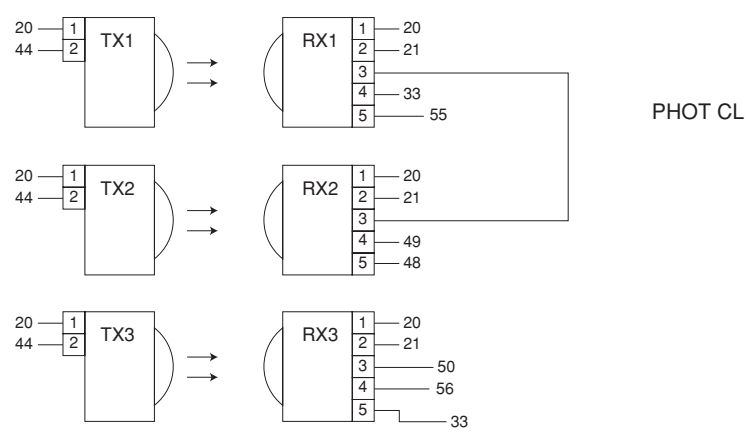
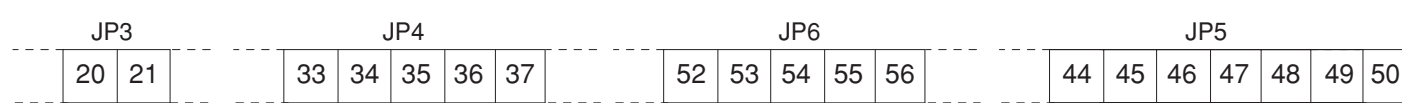

Fig. 18



TEST PHOT = ON  
 TEST PHOT CL = OFF  
 TEST BAR = ON  
 (TEST PHOT OP = ON)

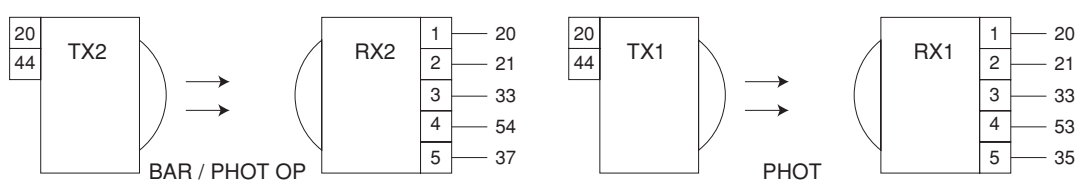
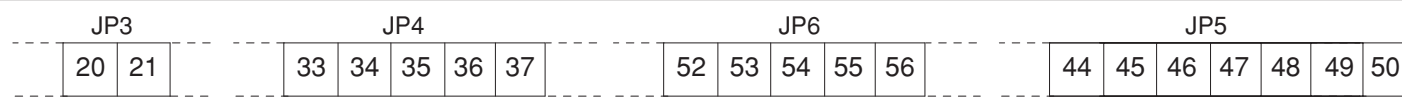

Fig. 19



TEST PHOT = ON  
 TEST PHOT CL = ON  
 TEST BAR = ON  
 (TEST PHOT OP = ON)

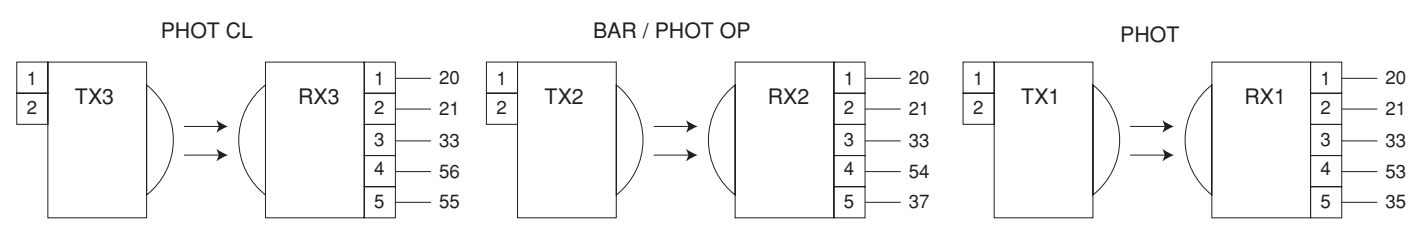
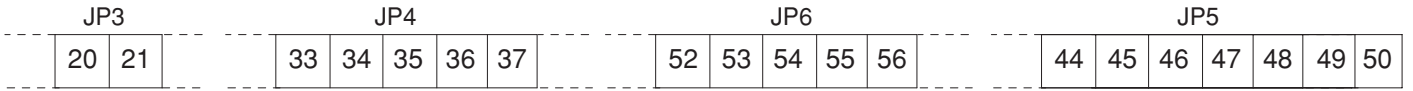

Fig. 20



TEST PHOT	=	ON
TEST PHOT CL	=	ON
TEST BAR	=	ON
(TEST PHOT OP	=	ON)

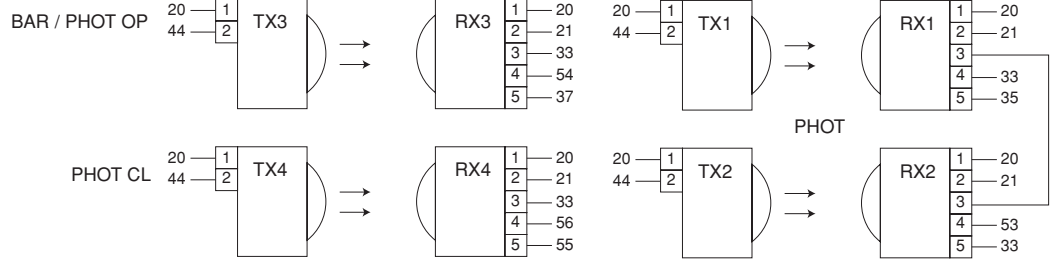
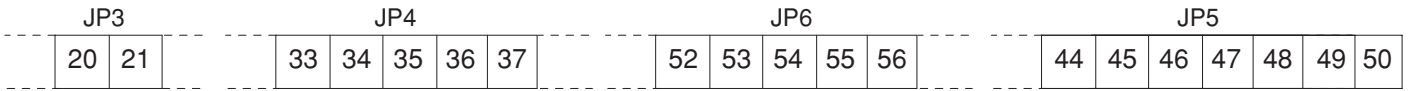
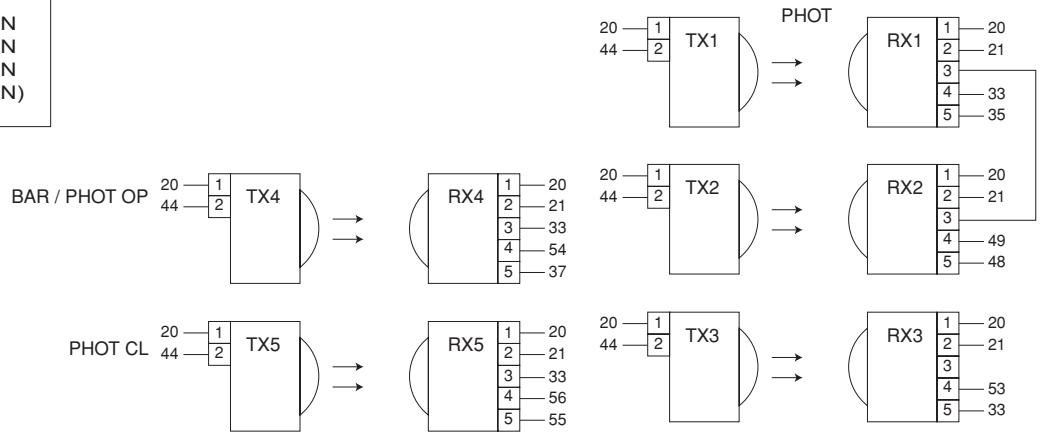

Fig. 21



TEST PHOT	=	ON
TEST PHOT CL	=	ON
TEST BAR	=	ON
(TEST PHOT OP	=	ON)



<b>BFT</b>	<b>FRANCE</b>	<b>BFT S.p.a.</b>	<b>ITALIA</b>
<b>AUTOMATISMES BFT FRANCE</b> 13 Bd E. Michelet, 69008 Lyon e-mail: infofrance@bft.it			
Tel. (0033) 0478760988 Fax (0033) 0478769223			
<b>BFT</b> <b>DEUTSCHLAND</b>			
<b>BFT Torantriebssysteme GmbH</b> Hintere Str. 100, 90768 Fürth <a href="http://www.bft-torantriebe.de">http://www.bft-torantriebe.de</a>		Via Lago di Vico, 44 36015 Schio (VI) Tel.naz. 0445 696511 Tel.int. +39 0445 696533 Fax 0445 696522 Internet: <a href="http://www.bft.it">www.bft.it</a> E-mail: <a href="mailto:sales@bft.it">sales@bft.it</a>	
Tel. 0911-7660090 Fax 0911-7660099			