

# CCpilot XL

## Technical Manual

maximatecc.

cr•ssc•ntr•l  
[www.crosscontrol.com](http://www.crosscontrol.com)



## Contents

<b>Contents</b> .....	<b>2</b>
<b>1. Introduction</b> .....	<b>4</b>
1.1. Identification .....	4
1.2. Care .....	4
1.3. Environment and Environmental Tolerance .....	4
1.4. Cleaning .....	5
<b>2. Overview</b> .....	<b>6</b>
2.1. CCpilot XL – Display unit .....	6
2.2. CCpilot XL – PC unit .....	6
2.3. Connecting the Display to the PC unit .....	7
2.4. Connectors .....	7
<b>3. Installation</b> .....	<b>8</b>
3.1. Placing and installing of the unit and peripherals .....	8
3.2. Mounting the PC unit separately .....	8
3.3. Mounting the display .....	8
3.4. Integrated installation, PC unit mounted on display unit .....	9
3.5. Mounting Cables .....	9
3.6. Connecting the Power supply .....	9
3.7. Heating via Preheating .....	10
<b>4. Basic operation</b> .....	<b>12</b>
4.1. Function of the Display's Push-buttons .....	12
4.2. Starting Up .....	12
4.3. Shutting-down .....	12
4.4. Touch screen .....	13
4.5. Back-up battery .....	13
<b>5. External interface description</b> .....	<b>14</b>
5.1. Power Supply Connector .....	15
5.2. USB (USB 1, USB 2, USB 3, USB 4) .....	15
5.3. Ethernet (Ethernet) .....	16
5.4. CAN (CAN1, CAN2) .....	16
5.5. COM .....	17
5.6. DMI - PC .....	17
5.7. DMI - Display .....	18
5.8. Audio .....	19
5.9. Video In (Video1, Video2) .....	19
5.10. VGA Out .....	20
<b>6. Software</b> .....	<b>21</b>
6.1. Operating System .....	21
6.2. CCP settings .....	21
<b>7. Specifications</b> .....	<b>23</b>
7.1. Computer Core .....	23
7.2. Power supply .....	23

7.3. Display .....	23
7.4. Environmental tolerance .....	24
7.5. Weight and dimensions.....	25
<b>8. Technical Support.....</b>	<b>28</b>
<b>Trade Mark, etc. ....</b>	<b>29</b>
<b>Index.....</b>	<b>30</b>

## 1. Introduction

In this technical manual you, as a user, a reseller or system integrator, will find important information about CCpilot XL. The handbook will guide you and inform you about this on-board computer's technical possibilities and advantages.

This manual covers the standard models of CCpilot XL. The CCpilot XL platform is also available additional configurations of hardware and software. Additional documentation can then be needed.

This material is copyright protected © 2010 CrossControl. All rights reserved.

### 1.1. Identification

There is a label on the back of the display and PC-unit of CCpilot XL. Printed on this labels are numbers which identify your unique computer. During service and other contact with the supplier it is important to be able to provide these numbers.



### 1.2. Care

- All cables shall be disconnected from your CCpilot XL during welding or other service on the machine where it is installed.
- CCpilot XL shall only be mounted and serviced by authorised personnel. If the unit is opened by unauthorised personnel, the normal guarantee will cease to be valid.
- Scratches, or in the worst case damages, to the display occur easily if it comes in contact with a sharp edge or hard material. In order to increase the longevity of the screen, this is naturally something which should be avoided.
- The unit can be damaged if it becomes too hot. Therefore, do not cover the unit by laying things on it, for example hanging a jacket or other clothes on it.
- Consider traffic safety when CCpilot XL is installed and whenever it is used. CrossControl does not recommend that CCpilot XL or its accessories be used actively by the driver when a risk of injury to people, or damage to property, is present.
- Be advised that CCpilot XL draws power from the vehicle battery. This can result in the inability of the vehicle to start if the onboard computer has been on for a period of time without the vehicle motor running.

### 1.3. Environment and Environmental Tolerance

CCpilot XL has been designed to cope with tough environmental demands. Strict tests have been conducted on the unit in order to ensure that it fulfils the expectations of a rugged unit and much work has been performed to choose and design internal components so that they, under all circumstances and in the best possible way, provide you with a dependable and user-friendly working instrument. Within the chapter Specifications, a list of standards can be found according to which CCpilot XL has been tested and approved.

CCpilot XL shall preferably be placed under a roof in order to prevent exposure to direct water contact. It is also important that it is mounted securely on a stand or the like to inhibit the unit from moving and thereby becoming damaged, damaging the vehicle and/or people during, for example, a traffic accident.

## 1.4. Cleaning

To ensure proper and reliable functionality over time, the unit shall be wiped cleaned of dirt and dust. Use a suitable light damp rag to clean the unit.



Never use alkaline, alcoholic or other chemicals for cleaning which can damage the unit.

## 2. Overview

CCpilot XL is a compact, robust and versatile on-board computer equipped with, among other things, a pressure-sensitive touch screen as well as a large number of connection alternatives such as CAN, COM, Ethernet and USB.

### 2.1. CCpilot XL – Display unit

On the display unit of CCpilot XL there are buttons for adjusting the screens brightness level and a status indicator. Depending on the configuration of the display it may also be equipped with a touch screen.

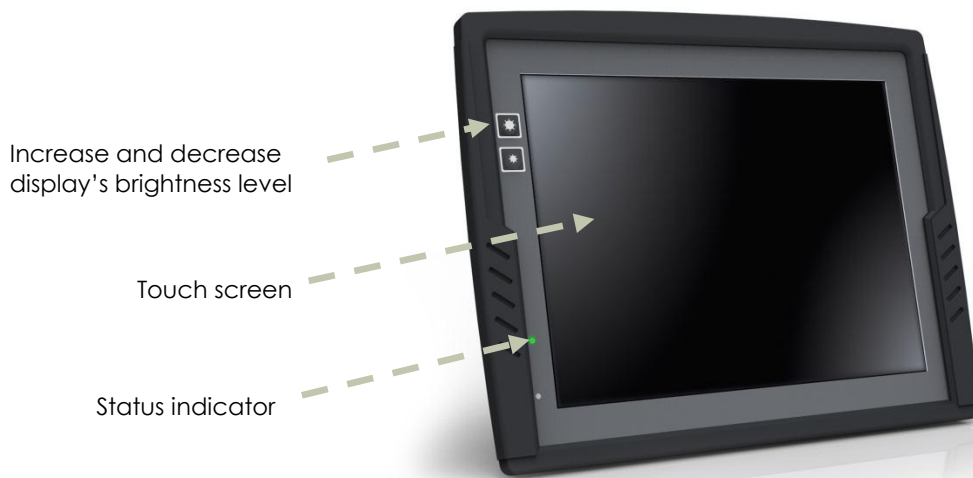

### 2.2. CCpilot XL – PC unit

CCpilot XL PC contains the processor unit and hard drive. It also provides easily accessible external connectors.

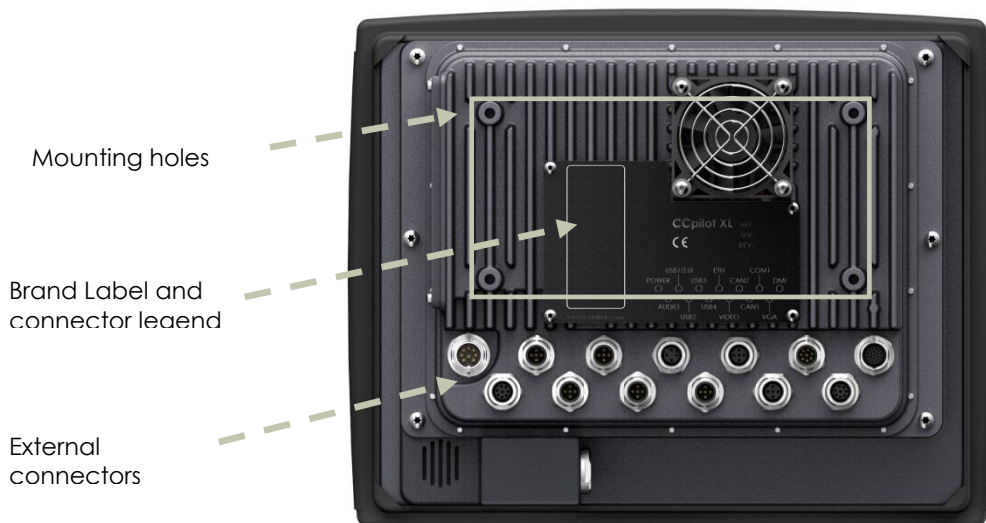

### 2.3. Connecting the Display to the PC unit

The display unit is connected to the PC unit with a DMI cable. The units can be mounted separately or, as shown in the illustration below, as an integrated unit when combined with the 12.1" display. The PC unit can also be configured to work with an external monitor using the VGA out signal or as a standalone PC unit without any display.



### 2.4. Connectors

The connectors on CCpilot XL are M12 connectors, except from the display and power supply connectors. Adapter cables are available as accessories, which make it possible to connect to standard consumer peripherals connectors. For more information about each interface see the chapter External interface description.

For more information on installing and setting up CCpilot XL see chapter Installation.

## 3. Installation

CCpilot XL must be installed in such a way that the unit is not exposed to any unnecessary stress or present any traffic danger. In this section, some recommendations are made regarding installation. For information about mounting accessories please contact your CCpilot XL reseller.



CCpilot XL shall only be serviced by authorized personnel. If the unit is opened by non-authorized personnel, the warranty becomes void.

### 3.1. Placing and installing of the unit and peripherals

CCpilot XL shall be installed in a ventilated space where air is able to circulate around the unit, therefore not near hot air vents or the like. There must be at least 50 mm distance between the unit and the closest partition or any other barrier. If the unit becomes too warm, it may not perform to its full capacity and, with high temperature, cease to function.



If the preceding instructions are not observed, the cooling of the unit can be degraded which can lead to overheating, consequently causing permanent damage to the unit.

When CCpilot XL or any device is installed in a vehicle environment it is important that the installation is traffic-safe. One should also avoid installing the unit where it will block the driver's view. This applies to both the instrument panel and the view through windshield. One should also think about how the placement affects personal safety in the event of a collision.



Consider traffic safety whenever CCpilot XL is installed and used in vehicle installations. CrossControl does not recommend that CCpilot XL or its accessories are used actively by the driver or operator when a risk of injury to people, or damage to property, is present.

### 3.2. Mounting the PC unit separately

The PC unit should be fastened onto suitable panelling in the cabin or someplace similar. This is done with the six mounting holes on the sides of the unit. Suitable fasteners, such as MRT M4x25 or MC6S M4x25 screws, can be used. The maximum tightening torque allowed is 1.0 Nm.

If the surface, on which the PC unit should be fastened, is not flat, care must be taken so as not to put mechanical tension on the unit during fastening. This can be solved appropriately by placing suitable spacers between the PC unit and the surface. An alternative solution is to use a separate, flat mounting plate for the PC unit. This plate is first fastened onto the desired area with separate screws, or by other means. Use thread lockers in all screw holes, e.g., Loctite 222.

We recommend installing CCpilot XL in such a way that it is not exposed to unnecessary vibration or other stress.

### 3.3. Mounting the display

#### 3.3.1. Bracket mount

CCpilot XL is preferably mounted on a convenient bracket which allows for adjustment of the display's position and angle. The bracket should have, or be provided with, a flat fastening plate to which the unit is bolted. The 10.4" display has mounting holes according to VESA 75 and the 12.1" display is according to VESA 100). To fasten, use appropriate M6 cap screw of type MC6S (Allen) or MRT (Torx). Note that the enclosure has blind holes, which give a maximum thread depth in the



enclosure of 6.5 mm. The maximum torque is 2.5 Nm. Apply a thread locker in all bolt holes, e.g. Loctite 222.

### 3.3.2. Panel Mount

With a front-mounted installation, use the rubber mask as a seal against the panel plate. The unit is locked down by applying clamps which are either fixed to the panel (recommended) or fixed to the unit through holes for VESA installation.

## 3.4. Integrated installation, PC unit mounted on display unit

An integrated installation can only be carried out on the PC unit together with the 12.1" display unit.

The same placing demands apply here, as when the units are mounted separately. Mounting, however, is carried out somewhat differently.

To fasten the PC and display units together, screws of type MC6S (Insex) or MRT (Torx), M4 x 25, should be used. The maximum tightening torque allowed is 1.0 Nm. Use thread lockers in all screw holes, e.g., Loctite 222.

The mounting holes on the PC unit's cooling flanges are used to screw the integrated unit onto a flat mounting plate. The mounting holes have M6 dimensions and are blind holes with a depth of 10 mm. Use screws of the correct length so that they do not hit the bottom of the mounting holes, and always use thread lockers in all screw holes, e.g., Loctite 222. Maximum tightening torque allowed is 9.8 Nm.



Note that the mounting plate, which is screwed onto the cooling flanges, should not cover a large area. This may cause poor cooling of the computer and damage it permanently.



If the screws used in the mounting holes hit the bottom, it may cause damage to the unit's enclosure.

## 3.5. Mounting Cables

Cables shall be installed so that they don't run the risk of being damaged, pinched or worn. Strain relief cable assemblies and avoid bending and twisting cables. The connectors shall always be screwed-in securely to give good contact and avoid unnecessary strain.

Through adapter cables, as supplied by CrossControl, standard connectors for Ethernet, USB and COM can be connected to the unit. The hook up of these adapter cables can and should be placed in a moisture-free, hidden space and should be secured and strain-relieved.

## 3.6. Connecting the Power supply

This instruction addresses vehicle installations but the principle is the same also for other types of installations. See also the description for the Power Supply Connector pin outs under the section External interface description.

Carefully follow the connection instructions below. Make sure that the contacts are the right way up and that they do not have to be forced, but lock gently and pliant.

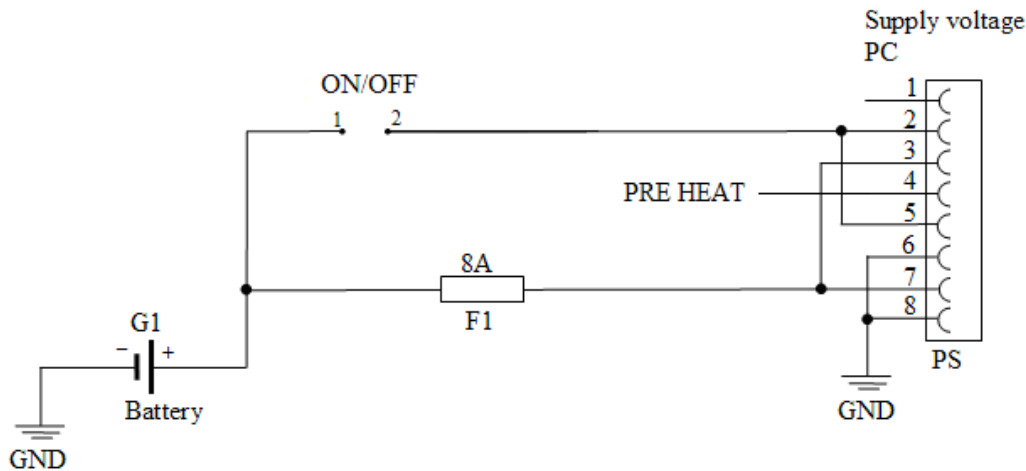

GND is connected to the vehicle's ground.

ON/OFF (pins 2 and 5) i.e. the computer's ON/OFF signal is connected to the battery or power source through a recoiling ON/OFF button.

Battery (pins 3 and 7), i.e. the computer's power supply (+24 VDC), should be connected directly to the vehicle's battery (G1) through an 8A fuse (F1).

Preheating (pin 4) allows preheating of the hard disk.

By connecting the power supply according to above, the on-board computer will start by a short push signal on the ON/OFF button, equal to starting a normal PC computer. To shut down CCpilot XL, push the ON/OFF button again or use the operating system shut down functionality.



### 3.6.1. Precautions

If applicable connect the computer before any main switch, as per the illustration above. If this is not possible, ensure that the computer is turned off using for example the on/off button or turnkey functionality before turning off the main switch or in any other way making the computer powerless.

Sudden power disruptions may cause the computer to shut down, potentially causing lost or corrupt data. If for example the power fluctuates when starting the vehicle engine, the computer should be started after the vehicle engine is running.

Ensure that any application data is saved before turning off the computer.

All cables shall be disconnected from your computer before any welding or other service action is performed on the vehicle.

## 3.7. Heating via Preheating

Preheating can be used to prepare for a direct start-up of CCpilot XL in low temperatures.

Preheating is initiated by a signal, from an external device, e.g., timer or motor heater, into pin 4 in the power supply contact on CCpilot XL. When the signal is high the temperature is continuously checked. If the temperature is below the defined setting the heater element is activated, by default +5 °C. To save battery power, the LED indication and display is not activated during preheat function.

The table below shows the time before the unit starts up at different temperatures using the default settings. External factors may affect the values; use them as an approximate guidance.

	-40°C	-30°C	-20°C	-10°C
Compact Flash	3 min	<1 min	0	0
HDD	20 min	15 min	10 min	5 min



Note that preheating consumes energy from the vehicle's battery. This can result in the vehicle not starting, after prolonged preheating of the PC and display, due to a flat battery.

## 4. Basic operation

This section covers basic operation of CCpilot XL unit such as start-up and shut down.

### 4.1. Function of the Display's Push-buttons

In the top left of the CCpilot XL display there are two buttons to control the screen brightness. Press and hold the button to gradually increase or decrease the display's brightness.

### 4.2. Starting Up

The unit is started by sending a short push signal to the ON/OFF pins in the power connector on CCpilot XL. For more information see the chapter connecting the Power Supply.

#### 4.2.1. Starting in the cold

Rotating hard drives should not be used in low temperature. To prevent damage, the temperature of the hard drive is checked and if needed warmed before start-up.

CCpilot XL will not start immediately when sending the ON/OFF signal and the temperature is lower than +5°C (+41°F). Instead, an internal heater will warm up the hard drive. During warm up the LED on the display will flash and the display will be activated.

Once the temperature for the hard disk is above +5°C, CCpilot will start automatically. The heater continues to warm the hard drive until it reaches +14°C.

To prepare for a fast start up in low temperatures preheating can be used. For more information see chapter, Heating via Preheating.

Values for the temperatures mentioned above are default values but can be changed from the CCP Settings program.

### 4.3. Shutting-down

To ensure that data does not get lost or the hard disk become corrupt, it is recommended that all programs are closed before the unit is shut down.

CCpilot XL can be shut down either from the operating system or from a short push signal on the ON/OFF input in the power connector.

#### 4.3.1. Forced shut-down

Setting the ON/OFF signal high for 5 seconds will perform a forced shut down. The forced shut down is a direct shut down of the computer without the control of the operating system. This shut down should normally be avoided and only be used when the computer is not responding to normal shut down.



Note that any information which was not saved will now be lost.

## 4.4. Touch screen

The CCpilot XL display is equipped with a touch screen which gives the opportunity to provide an easy-to-use HMI (Human Machine Interface) for the user.

### 4.4.1. Double and right click on the touch screen

To perform the equivalent to a right click on the touch screen first tap the place where the right click is supposed to be pressed and then tap the screen again slightly to the side of the initial tap.

To perform a double click on the touch screen, tap the screen twice in the same place.

### 4.4.2. Calibration of touch screen

If needed the touch screen can be calibrated. Calibration is started manually via the CCP Settings application. To keep the calibration data the administrator login must be done in CCP Settings.

Be thorough with this calibration for the best possible performance with your touch screen. You should use the same object (finger, stylus) during calibration which you think you will use later.



Don't use sharp or pointed objects on the touch screen since these can damage or scratch it, which can seriously degrade its functionality.

## 4.5. Back-up battery

Time and date information on CCpilot XL is stored in a memory sustained by a back-up battery.



This battery has a limited life time and must therefore be exchanged at regular intervals. The life time of the battery is approximately 3 years.

### 4.5.1. Exchanging the back-up battery

The battery is located on the hard-drive circuit board accessible behind the hatch on the side of the computer module. Perform the steps below to exchange the battery.

Before performing the battery exchange make sure that the PC is disconnected from power and any other connections.

1. Remove the two screws on the plate covering the HD-module
2. Carefully remove the plate
3. Pull out the HD-module using a suitable tool inserted in the two holes on the HD-module
4. Remove the battery from the battery holder
5. Insert a new battery. Type: BR1632 (3V)
6. Carefully push the HD-card back into the PC-unit. Make sure that the HD-module is inserted correctly.
7. Put back the plate and the screws.

## 5. External interface description

Accessible on the rear of CCpilot XL, there are a number of ports to connect various peripheral equipments. In order to give CCpilot XL its high environmental classification, the unit is equipped with DIN M12 connectors. CrossControl provides adapter cables which convert from DIN M12 to standard connectors.



Use caution and avoid plugging/unplugging of connectors when the computer is on. If the pins become bent or damaged they may not function correctly, or in the worst case, the onboard computer or other equipment may be damaged.

The connector legend describes where the connectors are located on your unit. The connectors available is dependent on the unit's configuration, therefore connections can be addressed which may not be available to your unit.

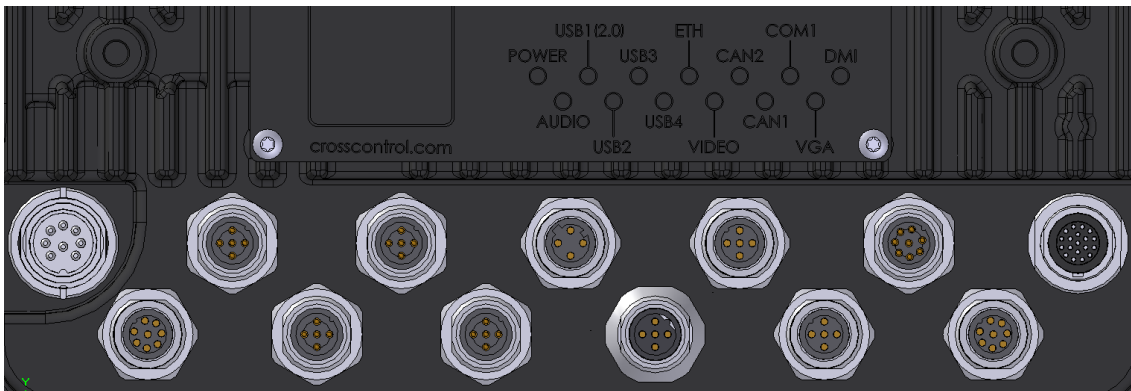

Position	Description
X1	Power Supply
X2	Audio
X3	USB 1
X4	USB 2
X5	USB 3
X6	USB 4
X7	Ethernet
X8	Video In
X9	CAN 2
X10	CAN 1
X11	COM
X12	VGA out
X13	DMI



Notice that the following connector descriptions are those which are located on the unit, not those that the attached cables shall have in order to mate with them.

## 5.1. Power Supply Connector

Marking: POWER IN

Connector Type: Serial 723 8 Pin, male

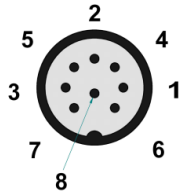

Pin	Signal	Description	Comments
1	NC		Not connected
2	Don	PC on	10-36 V = PC on
3	Dpow	Unswitched power	
4	Preheating		Signal to starts preheating of HD
5	Don	PC on	10-36 V = PC on
6	GND	Ground	
7	Dpow	Unswitched power	
8	GND	Ground	



For complete hook up instructions, see the section entitled Installation.

## 5.2. USB (USB 1, USB 2, USB 3, USB 4)

Marking: USB 1, USB 2, USB 3 and USB 4

Connector Type: DIN M12, 5-pole, A-coded, male

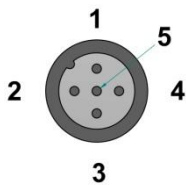

Pin	Signal	Description	Comments
1	Vbus	Power to external USB-unit	5 Volt, max 2A for USB 1 and max 500 mA for USB 2-4. Internal over current and shortcut protected.
2	D-	Data	
3	D+	Data	
4	NC		Not connected
5	GND	Ground reference	

Via the USB port, you can connect a multitude of devices to CCpilot XL. For some devices, drivers compatible with the operating system are required to be installed in order for the device to function.

The USB ports follow the USB 2.0 standard. Due to data communication safety in rough environments three of the four available USB connectors is limited to full speed (up to 12 Mbps). If high speed is necessary (up to 480 Mbps) the device must be connected to the USB 1.

USB connector 1 can supply up to 2A, USB 2-4 can supply up to 500mA each. The total current of all USB ports 1-4 has a max of 2A. The USB ports are internal over current and shortcut protected. An eventual cable shield is connected to the M12 connectors cover.

### 5.3. Ethernet (Ethernet)

Marking: Ethernet

Connector Type: DIN M12 4-pole, D-coded, female

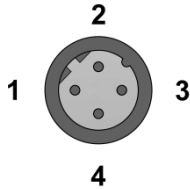

Pin	Signal	Description	Comments
1	TX+		
2	RX+		
3	TX-		
4	RX-		

With an Ethernet connection, CCpilot XL can access other units and networks. The Ethernet connector support 10/100 Mbps, i.e. communication speed up to 100 Mbps.

If shielded Ethernet cable is used the cable shield is connected to the M12 connectors cover.



Be aware that connecting CCpilot XL to a network environment can impose a security threat.

### 5.4. CAN (CAN1, CAN2)

Marking: CAN 2 and CAN 1

Connector Type: DIN M12, 5-pole A-coded, female

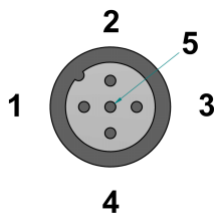

Pin	Signal	Description	Comments
1	CAN1 SHLD		
2	NC	No connection	
3	CAN GND		
4	CAN1 H	CAN1 High	
5	CAN1 L	CAN1 Low	

It is possible to connect two CAN-channels to CCpilot XL to connect a control system or, for example, the FMS system in a vehicle.

The interface has a PCA82C251 high speed transceiver installed and follows the ISO 11898-24V standard. Alternatively CCpilot XL CAN2 port can be equipped with the fault tolerant TJA1054AT transceiver.



Pinning of the CAN connector is according to the CANopen standard. The CAN connectors do not provide power out to external units. There is no termination in the interface; therefore, this shall be present in the cable.

CrossControl is well-experienced with control via the CAN-interface and both software and drivers are tested in various environments and under different conditions. Contact CrossControl if you need more information about our CAN-solutions.

## 5.5. COM

Marking: COM

Connector Type: DIN M12, 8-pole, A-coded, male.

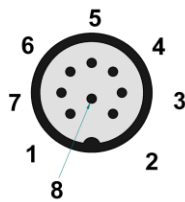

Pin	Signal	Description	Comments
1	DCD	Data Carrier Detect	
2	RxD	Receive data	
3	TxD	Transmit data	
4	DTR	Data Terminal Ready	
5	GND	Signal reference	
6	DSR	Data Set Ready	
7	RTS	Request To Send	
8	CTS	Clear To Send	

The COM port follows the RS232 standard except for the “Ring Indicator” signal, which has been omitted. The supported communication speed for these ports is 2.4 to 115.2 kbps. An eventual cable shield is connected to the M12 connectors cover.

## 5.6. DMI - PC

Marking: DMI

Connector Type: Lemo, female.

Pin	Signal	Description	Comments
1	TXOUT0-	LVDS	
2	TXOUT0+	LVDS	
3	TXOUT1-	LVDS	
4	TXOUT1+	LVDS	
5	TXOUT2-	LVDS	
6	TXOUT2+	LVDS	
7	TXCLK-	LVDS	
8	TXCLK+	LVDS	
9	DMI power supply	+24 V	
10	TFT_ON	TFT power control	
11	Beeper	Simple sound unit	
12	TS_Tx	Touch screen Tx	
13	TS_Rx	Touch screen Rx	

14	SPI_MISO	SPI data Display-PC	
15	RESET AVR	Reset input to AVR	Low in, while programming AVR. No connection in the cable
16	SPI_MOSI	SPI data Display-PC	
17	SPI_CLK	SPI clock Display-PC	
18	ON_OFF_2	On/off button from display to the PC	Not implemented
19	GND	Ground reference	

The DMI cable handles display and control signals between the CCpilot XL Display and PC-unit. The maximum recommended DMI cable length is 5.5 m.

Outer cable shield and LCDS double-shield is connected to the connector cover.

For information concerning the DMI connector on the display see chapter DMI - Display.

## 5.7. DMI - Display

Marking: DMI

Connector Type: Lemo, female.

Pin	Signal	Description	Comments
1	TXOUT0-	LVDS	
2	TXOUT0+	LVDS	
3	TXOUT1-	LVDS	
4	TXOUT1+	LVDS	
5	TXOUT2-	LVDS	
6	TXOUT2+	LVDS	
7	TXCLK-	LVDS	
8	TXCLK+	LVDS	
9	DMI power supply	+24 V	
10	TFT_ON	TFT power control	
11	Beeper	Simple sound unit	
12	TS_Tx	Touch screen Tx	
13	TS_Rx	Touch screen Rx	
14	SPI_MISO	SPI data Display-PC	
15	RESET AVR	Reset input to AVR	Low in, while programming AVR. No connection in the cable
16	SPI_MOSI	SPI data Display-PC	
17	SPI_CLK	SPI clock Display-PC	
18	ON_OFF_2	On/off button from display to the PC	Not implemented
19	GND	Ground reference	
20	VGA R	VGA Red	
21	VGA G	VGA Green	
22	VGA B	VGA Blue	
23	H Sync	Horizontal Sync	
24	V Sync	Vertical Sync	
25	VGA enable		Put to gnd when enabled
26	GND VGA	Ground reference	

The DMI cable handles display and control signals between the CCpilot XL Display and PC-unit. The maximum recommended DMI cable length is 5.5 m.

Outer cable shield and LCDS double-shield is connected to the connector cover.

For information concerning the DMI connector on the PC unit see chapter DMI - PC.

## 5.8. Audio

Marking: Audio

Connector Type: DIN M12, 8-pole, A-coded, female.

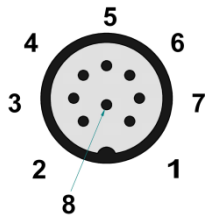

Pin	Signal	Description	Comments
1	Line out L		
2	Line out R		
3	GND (Speaker)		Shield in cable
4	Microphone		
5	Mic. Ref.		Microphone reference
6	Speaker output L		Amplified
7	Speaker output R		Amplified
8	GND (Line out)		Shield in cable

The audio offers possibilities to play everything from warning sound to music directly from CCpilot XL two channel speaker stereo output. The output offers both line out signal and amplified speaker out. Microphone in is also available for sound recording or to present the sound from, for example, cameras.

Volume is set by the volume controls within Windows.

## 5.9. Video In (Video1, Video2)

Marking: VIDEO

Connector Type: DIN M12, 5-pole, B-coded, male.

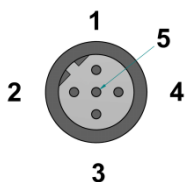

Pin	Signal	Description	Comments
1	GND	GND Video A	
2	Video A	PAL/NTSC input A	
3	Video B	PAL/NTSC input B	
4	12V_OUT	Power out +12 V	Power supply to video camera, Max 300 mA
5	GND	GND Video B	

The Video connector has two composite video inputs for the attachment of video sources such as rear view cameras. It supports PAL, the European video format, as well as NTSC, the American standard.

The video connector can be used to power external cameras using the 12V unfiltered supply. The output has a current limit that depends on the internal unit temperature. The current is limited to 0.150A at an internal unit temperature of 70 degrees Celsius and around 0.2A in normal working conditions.

The cable which is used to connect the camera to the computer shall be a 75-Ω coaxial cable, e.g. M17/94-RG179. An eventual outer cable shield is connected to the M12 connectors cover.



Ensure that there is no DC-offset (supply current) on the video signal connected since this can cause damage to your CCpilot XL.

### 5.10. VGA Out

Marking: VGA

Connector Type: DIN M12, 8-pole, A-coded, female.

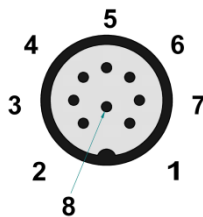

Pin	Signal	Description	Comments
1	VGA R	VGA Red	
2	VGA G	VGA Green	
3	VGA B	VGA Blue	
4	H Sync	Horizontal Sync	
5	V Sync	Vertical Sync	
6	GND R	Ground reference Red	Shield on VGA Red cable
7	GND G	Ground reference Green	Shield on VGA Green cable
8	GND B	Ground reference Blue	Shield on VGA Blue cable

The VGA out can be used as external displays to the CCpilot XL PC unit, either as a stand-alone head display or as dual display together with the CCpilot XL display.

Outer cable shield is connected to the cable connector cover.

## 6. Software

This section gives a short description to some of the computer specific software supplied with CCpilot XL.

### 6.1. Operating System

CCpilot XL is by default supplied with Windows XP and the following described software tools targets Windows users. CCpilot XL can also be used with other operating systems, contact your sales representative for more information.

CCpilot XL offers a multitude of connection alternatives, for instance via USB. In order for the device connected to CCpilot XL to function correctly, sometimes drivers must be installed. CrossControl can only guarantee the function for applications and devices which are tested and approved by CrossControl.

### 6.2. CCP settings

CCP settings is a software to view and configure CCpilot XL specific parameters and settings.

Changes to the parameters are not performed unless an administration login is made into CCP Settings. Also, many of the settings require administration privileges on the computer to be able to store the settings. The login is made from the Status tab in CCP Settings and the password is CCPILOT.



CrossControl does not take any responsibility for any resulting damage or injury given as a result of reconfiguring CCP settings.

#### 6.2.1. Open CCP Settings



CCP settings is opened either from the Control panel or from the light bulb icon located in the status notification area in the task bar.



### 6.2.2. CCP setting status

The colour of the light bulb indicates the CCP setting status.



**RED** – Not active. The CCP settings service is not started or something is wrong in the communication with the computer. Within this state the display led and push buttons are not in communication with the PC unit and therefore not functional.



**YELLOW** – Active and waiting. The CCP settings service is in idle state.



**GREEN** – Busy. The CCP settings service is operating with the computer.

### 6.2.3. The Status tab

The status tab presents information about the firmware versions loaded on the unit.

The status tab also has an administrator login button. The administrator login gives access to more parameters.

### 6.2.4. The general tab

From the general tab it is possible to alter the steps for the dimming buttons. It is also possible to assign other functionality than dimming of the backlight to the dimming buttons.

### 6.2.5. The temperature tab

The temperature tab gives status information about the unit's internal temperature as well as information regarding the temperature control functions.

### 6.2.6. The shut-down tab

From the shut-down tab it is possible to configure how the computer handles shut down procedure.

### 6.2.7. The touch-screen tab

The touch-screen tab offers calibration of the touch screen functionality.

## 7. Specifications

The specification may vary depending on your computer configuration.

### 7.1. Computer Core

Core Component	Description	Comments
Processor	Intel Pentium Core Duo, 1,6 GHz	
Storage	Compact Flash (8 GB to 16 GB) or rotating hard disk (2"5, 40 GB) exchangeable via hatch on enclosure	40 GB rotating disc default.
RAM	2048 MB SDRAM	

Interface	Description	Comments
CAN	2 pcs. 2.0B, ISO 11898 – 24V, PCA82C251 transceiver, 1 Mbit	Optional: TJA1054AT - fault tolerant transceiver
USB	4 pcs.	Ver. 2.0, 3 full speed, 1 high speed
Video in	2 pcs.	Zoomed composite video signal
RS232	1 pcs.	<= 115 000 baud
Ethernet	2 pcs.	10/100 Base-T
Touch screen	Resistive Touch screen	8-wire
Audio	Line out Speaker out Mic in	1V RMS at 10k 4W/channel at 4Ω
VGA out	1 pcs	Dual screen or dual display
DMI	1 pcs	VGA out and display signals

### 7.2. Power supply

Power Supply	Description	Comments
Supply Voltage	24 V nominal	
Power Consumption	< 2A at 24 V	

### 7.3. Display

Display	Description	Comments
10"4	Colour, XGA, 320 cd/mm*	Aspect Ratio 4:3
12"1	Colour, XGA, 320 cd/mm*	Aspect Ratio 4:3

## 7.4. Environmental tolerance

Environmental Test	Standard													
Dry Heat	IEC 60068-2-2 Bd	Operating: +55°C, 24h Storage: +60°C, 24h												
Damp Heat	IEC 60068-2-30 Db	Operation: +25°C / +55°C >93% RH 6*24h (without touch screen)												
Cold	IEC 60068-2-1 Ad	Operating: -25°C, 24h Storage: -40°C, 24h												
Change of temperature	IEC 60068-2-14 Nb	-25°C - +30°C, 5C/min 3hr hold time, 20 cycles												
Vibration	IEC 60068-2-64	0,01 g <sup>2</sup> /Hz 10-200 Hz 1,39g (RMS) 3x0,5h												
Shock	IEC 60068-2-29	5 g / 11 ms 3x ±1000 bumps												
EMC Electrical Transient	ISO 7637-2	Pulse 1: -50V /2mS 2: +25V /2mS 3a: -220V /1mS 3b: +220V /1mS 4: -5V 5: +70V												
EMC Immunity, ESD	EN 61000-4-2	8 kV air, 6 kV contact												
EMC Immunity, RF	ISO 11452-2  ISO 11452-4	RF electromagnetic field 200-1000MHz 30V/m 80%AM  Bulk Current Injection 20-200MHz 60mA 80%AM												
EMC Emission	ISO 14982	<table border="1"> <thead> <tr> <th>MHz</th> <th>Narrowb. dBµV/m</th> <th>Broadb. dBµV/m</th> </tr> </thead> <tbody> <tr> <td>30-75</td> <td>54-44</td> <td>64-54</td> </tr> <tr> <td>75-400</td> <td>44-55</td> <td>54-65</td> </tr> <tr> <td>400-1000</td> <td>55</td> <td>65</td> </tr> </tbody> </table>	MHz	Narrowb. dBµV/m	Broadb. dBµV/m	30-75	54-44	64-54	75-400	44-55	54-65	400-1000	55	65
MHz	Narrowb. dBµV/m	Broadb. dBµV/m												
30-75	54-44	64-54												
75-400	44-55	54-65												
400-1000	55	65												
Enclosure	EN 60529	IP54												

The tests are performed with 24 V power level. The environmental tolerance may be affected by external factors like mounting, cables, etc.



## 7.5. Weight and dimensions

### 7.5.1. PC unit

	Description	Comments
Enclosure size	268 x 196 x 56 mm (W x H x D)	

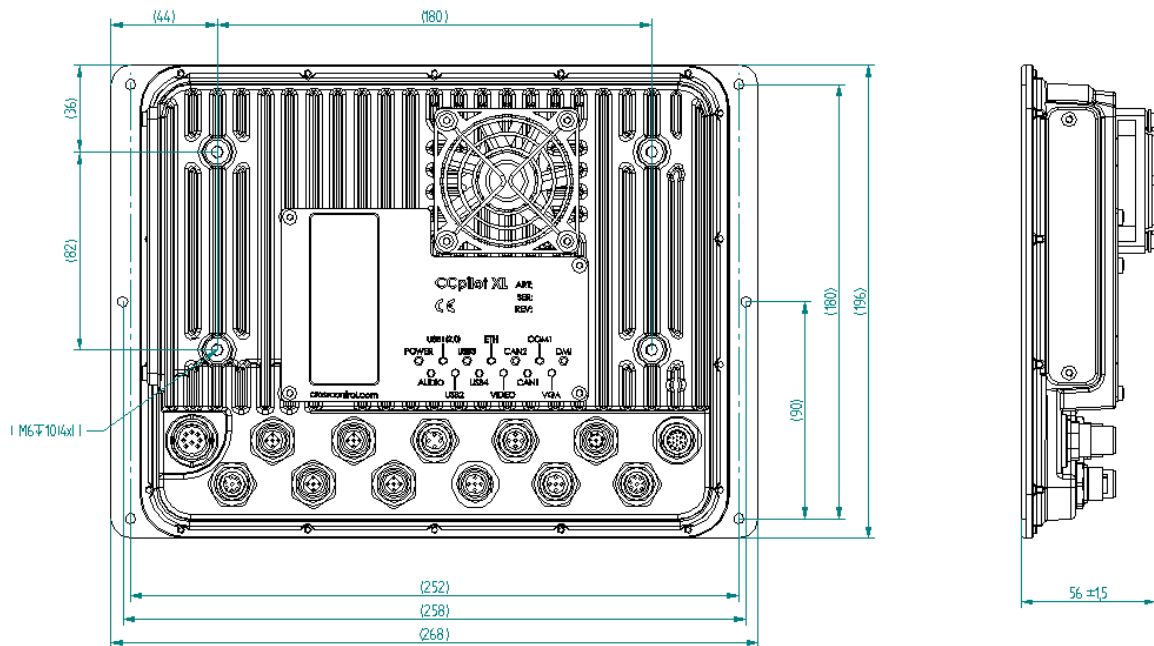

7.5.2. 10.4" Display

	Description	Comments
Enclosure size	286 x 217 x 57 mm (W x H x D)	

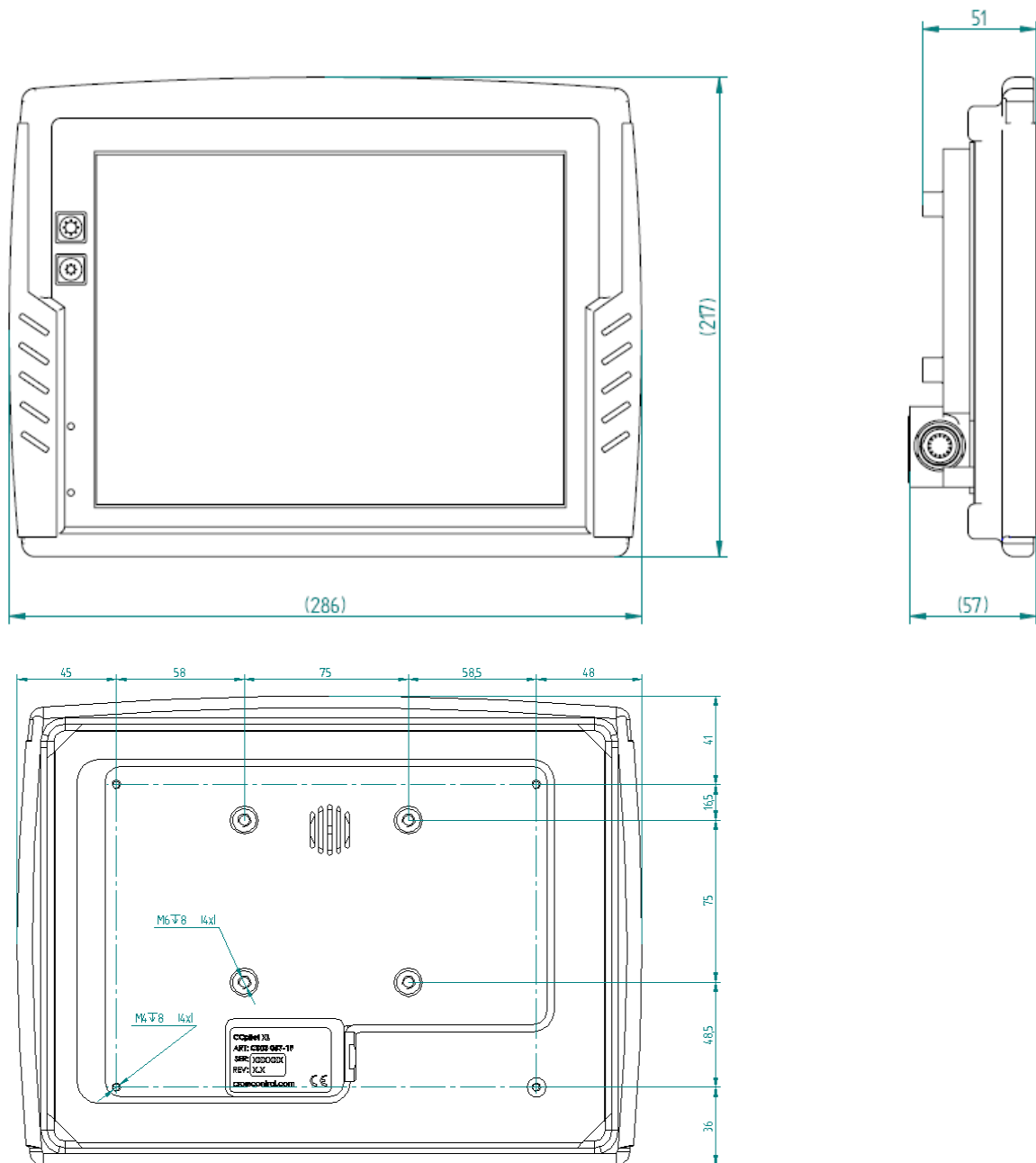

### 7.5.3. 12" Display

	Description	Comments
Enclosure size	322 x 257 x 60 mm (W x H x D)	

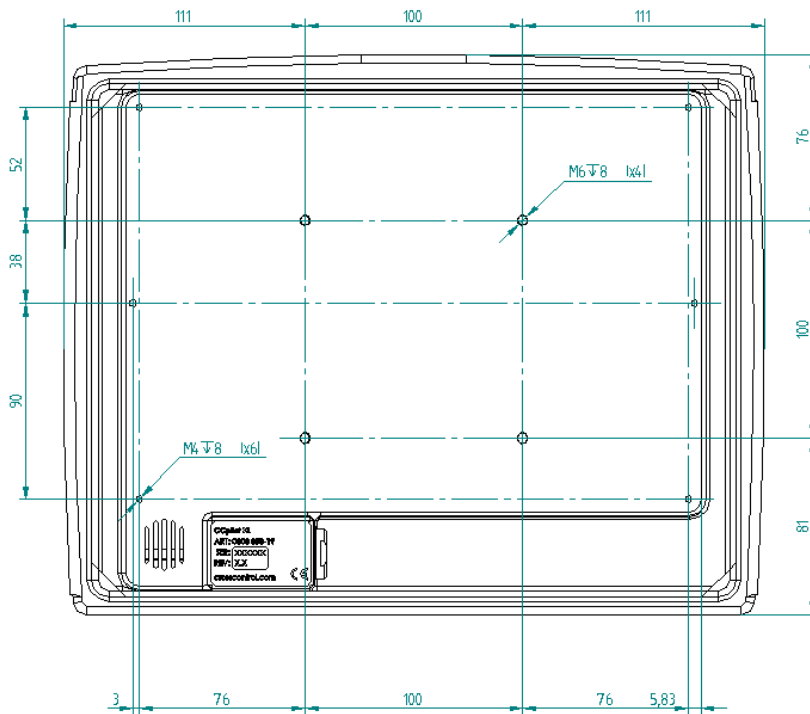
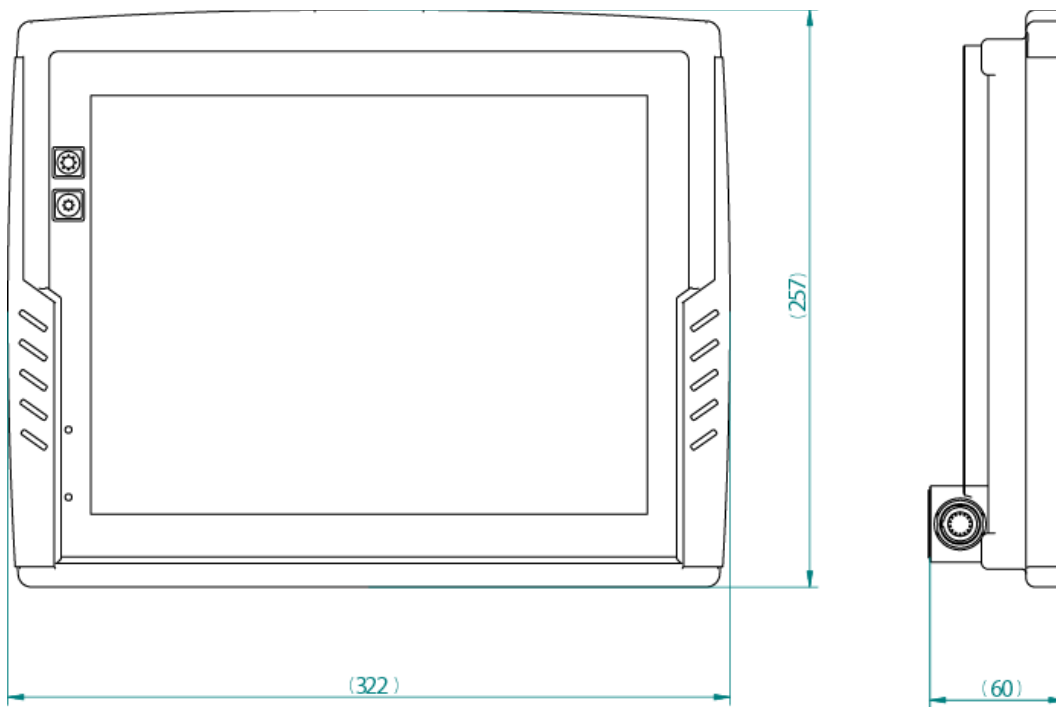

## 8. Technical Support

Contact your reseller or supplier for help with possible problems with your CCpilot XL. In order to get the best help, you should have your CCpilot XL in front of you and be prepared with the following information before you contact support.

- Part number and serial number of the unit, which you find on the brand label
- Date of purchase, which is found on the invoice
- The conditions and circumstances under which the problem arises
- Possible error messages which are shown.
- Version number of the operating system, which you find via the *Start* menu: go to the *Control Panel* and click on *System*.
- Information regarding possible external equipment which is connected to CCpilot XL.

## Trade Mark, etc.

© 2010 CrossControl AB

All trademarks sighted in this document are the property of their respective owners.

CCpilot is a trademark which is the property of CrossControl AB.

Intel is a registered trademark which is the property of Intel Corporation in the USA and/or other countries. Linux is a registered trademark of Linus Torvalds. Microsoft and Windows are registered trademarks which belong to Microsoft Corporation in the USA and/or other countries. CANopen is a registered trademark of CAN in Automation (CiA).

CrossControl AB is not responsible for editing errors, technical errors or for material which has been omitted in this document. CrossControl is not responsible for unintentional damage or for damage which occurs as a result of supplying, handling or using of this material. The information in this handbook is supplied without any guarantees and can change without prior notification.

## Index

<b>A</b>	
Adapter cables.....	14
Audio port.....	19
<b>B</b>	
Back-up battery.....	13
Basic operations.....	12
Battery.....	9, 10
Bracket Mount.....	8
<b>C</b>	
Cable installation.....	9
Calibrate touch screen.....	13
Calibration.....	13
Camera connection.....	19
CAN.....	16, 23
Care.....	4
CCP settings.....	21
Cleaning.....	5
COM.....	17
Communication port.....	17
Composite video.....	20
Computer Core.....	23
Connecting the Display to the PC unit.....	7
Connectors.....	14
Contact support.....	28
Cooling.....	8
<b>D</b>	
Display.....	23
Display installation.....	8
Display unit.....	6
DML.....	23
DML on display.....	18
DML on PC unit.....	17
Double click.....	13
<b>E</b>	
Enclosure size 10.4.....	26
Enclosure size 12.....	27
Enclosure size PC unit.....	25
Environmental test.....	24
Environmental tolerance.....	24
Environmental Tolerance.....	4
Ethernet.....	16, 23
External interface description.....	14
<b>F</b>	
Flash memory.....	23
Forced Shut Down.....	12
<b>G</b>	
Fuse.....	9
<b>H</b>	
Hook up of Power supply.....	9
<b>I</b>	
Identification.....	4
Inputs.....	14
Installation of CCpilot XL.....	8
Installing cables.....	9
Integrated.....	7
Introduction.....	4
<b>L</b>	
Label.....	4
LAN.....	16
<b>M</b>	
Maintenance.....	5
Monitor.....	20
Mounting holes.....	8, 9
Mounting the display unit.....	8
Mounting the PC unit.....	8
<b>N</b>	
Network connector.....	16
NTSC.....	20
<b>O</b>	
ON/OFF.....	9
ON/OFF signal.....	10, 15
Operating System.....	21
Outputs.....	14
Overview of CCpilot XL.....	6
<b>P</b>	
PAL.....	20
Panel Mount.....	9
PC unit.....	6
PC unit installation.....	8
Performance.....	23
Pins.....	14
Placement of CCpilot XL.....	8
Ports.....	14
Power.....	15

Power Consumption .....23  
 Power Supply Connector.....15  
 Power supply installation .....9  
 Preheating ..... 10, 12  
 Processor .....23  
 Push-buttons .....12

**R**

RAM memory .....23  
 Right click.....13  
 RS232..... 17, 23

**S**

Serial port .....17  
 Shutting-Down.....12  
 Software .....21  
 Specification .....23  
 Starting in the cold .....12  
 Starting Up .....12  
 Supply Voltage .....23  
 Support .....28

**T**

Technical Support .....28

Test standards .....4  
 Thread lockers .....8  
 Tightening torque ..... 8, 9  
 Torque.....9  
 Touch screen..... 13, 23  
 Trade Mark.....29  
 Traffic safety .....8  
 Turning off .....12  
 Turning on .....12

**U**

USB..... 15, 23  
 Using CCpilot XL.....21

**V,W**

Warming..... 10, 12  
 Warranty.....8  
 Vehicle's fuse .....9  
 Weight and dimensions.....25  
 VGA .....20  
 Video ..... 19, 23  
 Video camera.....19  
 Windows XP .....21



**CrossControl AB**  
 P.O. Box 83 • SE 822 22 Alfa • Sweden  
 Phone: +46 271 • www.crosscontrol.com