

# Mania DC3

user manual



**Martin**

Measurements are expressed in millimeters.

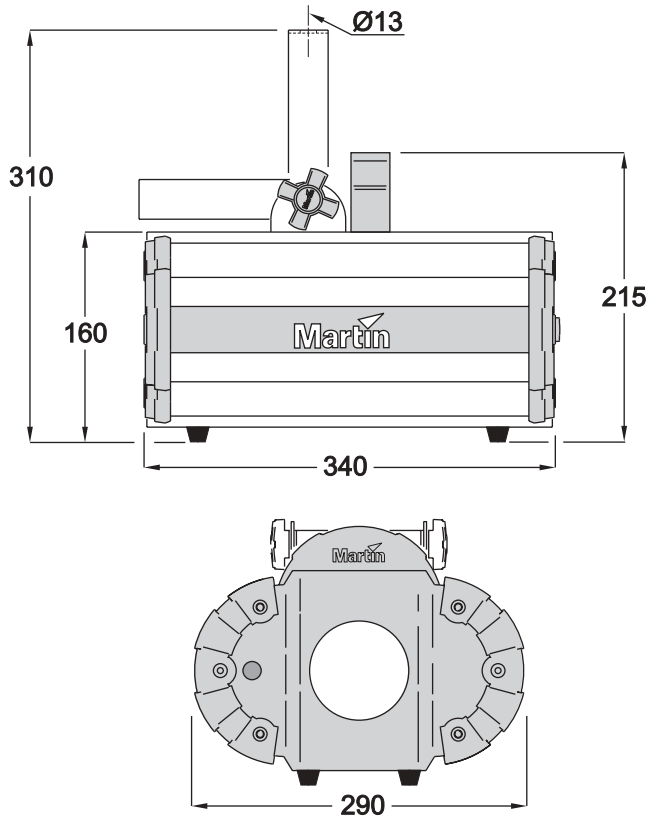

© 2004 Martin Professional A/S, Denmark.

All rights reserved. No part of this manual may be reproduced, in any form or by any means, without permission in writing from Martin Professional A/S, Denmark.

Printed in China.

P/N 35000156, Rev. A.

- Introduction** . . . . . 5
  - Safety information . . . . . 5
  - Unpacking . . . . . 7
  - Mania DC3 overview . . . . . 8
  
- Installation** . . . . . 9
  - AC power . . . . . 9
  - Choice of mounting . . . . . 10
  
- Operation** . . . . . 12
  - Focusing the Mania DC3 . . . . . 12
  - Oil wheel rotation . . . . . 13
  - Remote control operation . . . . . 13
  
- Basic service** . . . . . 14
  - Cleaning . . . . . 14
  - Lamp maintenance . . . . . 15
  - Installing an oil wheel . . . . . 17
  - Installing a gobo or filter . . . . . 19
  - Reconfiguring the beam . . . . . 20
  - Lens assembly . . . . . 23
  - Replacing the mains fuse . . . . . 23
  
- Troubleshooting** . . . . . 24
  
- Specifications** . . . . . 25



# INTRODUCTION

Thank you for selecting a Martin Mania DC3. The Mania DC3 is a motorized oil wheel projector that features variable oil wheel rotation speed and direction as well as remote operation in which up to four fixtures can be controlled from one remote control. The beam angle can be adjusted from 25° to 32°. A 43° beam angle can also be obtained using a separately available accessory.

## SAFETY INFORMATION

---

***Warning! This product is not for household use. It presents risks of lethal or severe injury due to fire and heat, electric shock, and falls.***

Read this manual before powering or installing the fixture, follow the safety precautions listed below and observe all warnings in this manual and printed on the fixture. If you have questions about how to operate the fixture safely, please contact a Martin distributor for assistance. Refer any service operation not described in this manual to a qualified technician. Do not modify the fixture or install other than genuine Martin accessories and upgrade kits.

Refer servicing to qualified personnel.

Maximum ambient temperature  $T_a = 40^{\circ}\text{C}(104^{\circ}\text{F})$ .

See serial label for replacement fuse size and lamp type.

Suitable for mounting on normally flammable surfaces.

Do not look directly into the light.

Risk of fire, electrical shock and burns.

Use only in dry locations.

For indoors use only.

Do NOT block exhaust vents.

Shields, lenses or ultraviolet screens must be changed if they become visibly damaged to the extent that their effectiveness is impaired, for example, by cracks or deep scratches.

The lamp must be changed if it becomes damaged or thermally deformed.

If the external power cord of this luminaire is damaged, it must be replaced by a special cord exclusively available from your Martin dealer.

## Avoiding electric shocks

**Warning** *Always disconnect from mains power before replacing the lamp, fuses, or any part, and when not in use.*

- Before operation ensure that factory setting of voltage and frequency match local power supply.
- Always ground (earth) the fixture electrically.
- Use only a source of AC power that complies with local building and electrical codes and has both overload and ground-fault protection.
- Do not expose the fixture to rain or moisture.
- Never operate the fixture with missing or damaged lenses and/or covers.

## Protecting yourself and others from burns and fire

**Warning** *Hot lamp. The exterior of the fixture can become hot. Allow to cool for at least 20 minutes before handling or opening.*

- Surface temperature under steady state condition = 95°C (203° F).
- Minimum distance to flammable material = 0.3 m (1 ft).
- Minimum distance to illuminated surface 1.0 m (3.3 ft).
- Never attempt to bypass the thermostatic switch or fuses. Always replace defective fuses with ones of the specified type and rating.
- Ensure that the air flow through vents is free and unobstructed.
- Provide a minimum clearance of 0.1 meters (4 inches) around air vents.
- Never place filters or other materials over the lens or in the optical path.
- The exterior of the fixture can become hot. Allow the fixture to cool for at least 20 minutes before handling.
- Do not operate the fixture if the ambient temperature ( $T_a$ ) exceeds 40° C (104° F).
- Never operate the fixture without all lenses and covers installed: an unshielded lamp emits dangerous UV radiation that can cause burns and eye damage.

## Preventing injuries due to falls

- When suspending the fixture above ground level, check that the structure can hold at least 10 times the weight of all installed devices.
- Always work from a stable platform.
- Check that all external covers and rigging hardware are securely fastened and use an approved means of secondary attachment such as a safety cable.
- Block access below the work area whenever installing or removing the fixture.

## UNPACKING

---

The packing material is carefully designed to protect the fixture during shipment – always use it to transport the fixture.

The following items are supplied with the Mania DC3:

- 3-wire (grounding/earthing-type) power cable
- User manual
- Oil wheel
- 2mm Allen key for installing oil wheel and changing beam angle.
- Remote control unit with 5-meter (16.4 ft.) RJ-45 cable
- White glove with Martin logo

# MANIA DC3 OVERVIEW

---

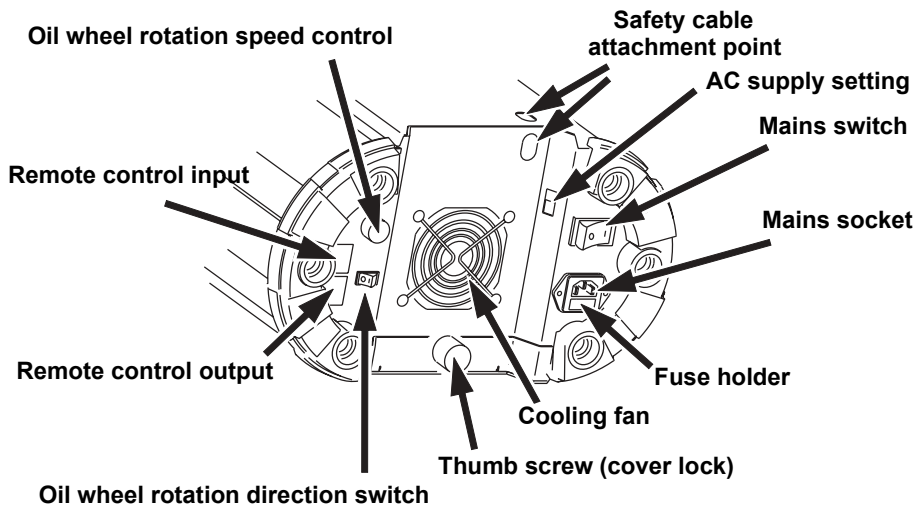



# INSTALLATION

# 2

## AC POWER

---

Before operation, ensure that the factory-set voltage and frequency match the local power supply.

Always ground (earth) the fixture electrically.

Use only a source of AC power that complies with local building and electrical codes and has both overload and ground-fault protection.

**Note:** *If the external power cord of this luminaire is damaged, it must be replaced by a special cord exclusively available from your Martin dealer.*

### Configuring for local mains power

The Mania DC3 has a switch-selectable power supply that can operate in the following voltage ranges at 50-60 Hz:

- 115 - 120 volts (setting 115)
- 220 - 240 volts (setting 230)

**Warning** *Do not operate the fixture on a power supply that falls outside of these ranges.*

Select the operating range using the red AC supply switch at the rear of the fixture.

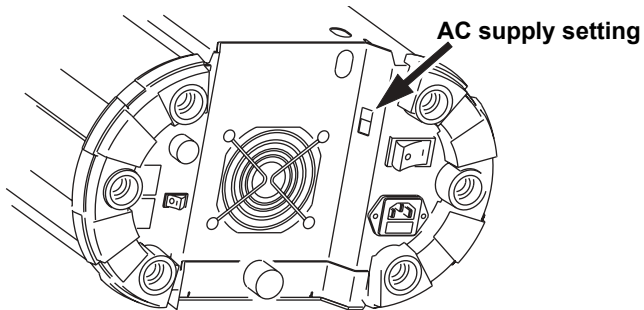

## Installing a plug on the mains lead

**Warning!** *For protection from dangerous electric shock, the fixture must be grounded (earthed). The AC mains supply must have overload and ground-fault protection.*

**Important!** *Check that the feed cables are undamaged and rated for the current requirements of all connected devices before use.*

The fixture's mains lead may require a grounding-type cord cap that fits your power distribution cable or outlet. Consult a qualified electrician if you have any doubts about proper installation.

Following the cord cap manufacturer's instructions, connect the appropriate wires to ground (earth), live, and neutral. The following table below shows some common wire identification schemes.

Function	Wire (EU)	Wire (US)
live	brown	black
neutral	blue	white
ground	yellow/green	green

Applying power

1. Connect the mains power cable to the fixture at the 3-prong IEC male input socket at the rear of the fixture.

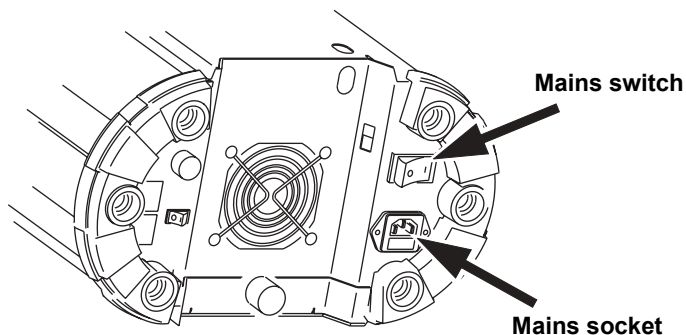

2. Turn the power on using the mains switch.

## CHOICE OF MOUNTING

---

The Mania DC3 may only be operated in a standing position or hung overhead with a clamp. The fixture can be installed at an angle pointing

either up or down, but bear in mind that the oil wheel is affected by gravity. Installing the fixture too far away from a horizontal position will affect oil wheel performance.

## Overhead mounting

**Warning!** *Block access below the work area before proceeding.*

*Always use a secure means of secondary attachment.*

*For indoors use only.*

To hang the Mania DC3 on an overhead support:

1. Check that the structure can support at least 10 times the weight of all installed fixtures, clamps, cables, auxiliary equipment, and other items.
2. If hanging the fixture with a rigging clamp, check that the clamp is undamaged and is designed for the fixture's weight. Bolt the clamp securely to the mounting bracket on the fixture with a grade 8.8 (minimum) M12 bolt and lock nut, or as recommended by the clamp manufacturer, through the clamp hole in the mounting bracket.
3. If permanently installing the fixture, check that fasteners and mounting surface can bear at least 10 times the fixture's weight.
4. Working from a stable platform, clamp or fasten the fixture to the structure.
5. Install a safety cable that can hold at least 10 times the weight of the fixture through the safety cable attachment point on the fixture.

### Safety cable attachment point

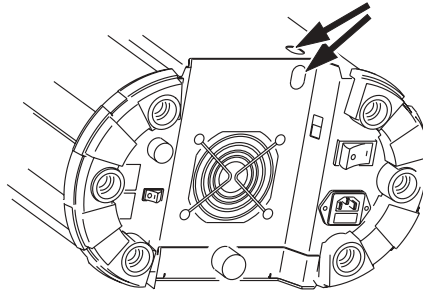

6. Loosen the swivel locks, tilt the fixture to the desired angle, and retighten.
7. Check that the fixture is at least 1 meter (3.3 ft.) from the surface to be illuminated and at least 0.3 meters (1 ft.) from any combustible materials. Check that the clearance around the air vents is at least 0.1 meters (4 in.).

# OPERATION

# 3

The lamp will light when the mains switch at the rear of the fixture is turned on.

## FOCUSING THE MANIA DC3

---

Focus is adjusted using the knob next to the lens. Twist the knob until a sharp image is acquired. Do not look directly into the light.

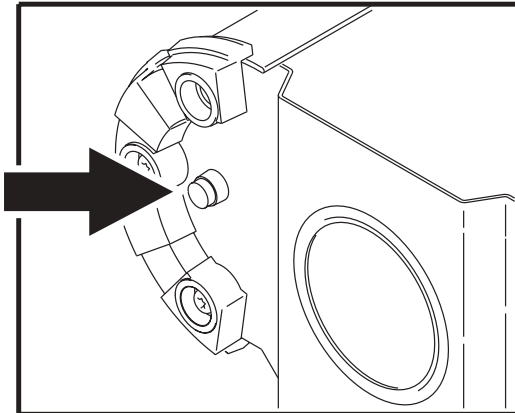

## OIL WHEEL ROTATION

---

You can adjust the speed and direction of the oil wheel rotation using the controls at the rear of the fixture.

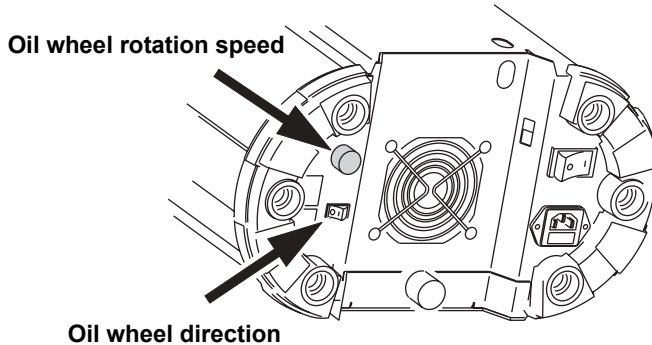

## REMOTE CONTROL OPERATION

---

The remote control unit can control up to four daisy-chained Mania DC3s. Connect the remote control to the RJ-45 In connector on the first Mania DC3 fixture and connect successive fixtures using the RJ-45 Out connector.

The maximum cable length between daisy-chained fixtures is 10 metres (33 ft).

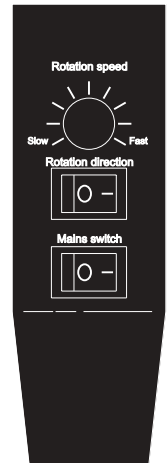

# BASIC SERVICE

# 4

This chapter describes the maintenance procedures that you can perform yourself.

**Warning** *The exterior of the fixture can become hot. Always disconnect the fixture from AC power and allow to cool for at least 20 minutes before handling or opening.*

## CLEANING

---

Regular cleaning of the elements in the optical path, as well as the air vents, is vital to maintaining the operational quality of the Mania DC3.

**Important!** *Excessive dust, smoke residue and particle buildup degrades performance and causes overheating and damage to the fixture that is not covered by the warranty.*

### Cleaning the air vents and fan

To maintain adequate cooling, dust must be cleaned from the air vents periodically. Remove dust from the air vents with a soft brush, cotton swab, vacuum, or compressed air.

### Cleaning optical components

Clean the optical components regularly. The presence of smudges or dust on optical surfaces can reduce the strength of the light output and the quality of the effects.

Use care when cleaning optical components and work in a clean, well lit area. The coated surfaces are fragile and easily scratched. Do not use solvents that can damage plastic or painted surfaces.

1. Disconnect the fixture from power and allow it to cool for 20 minutes.

2. Remove the thumb screw holding the cover in place.

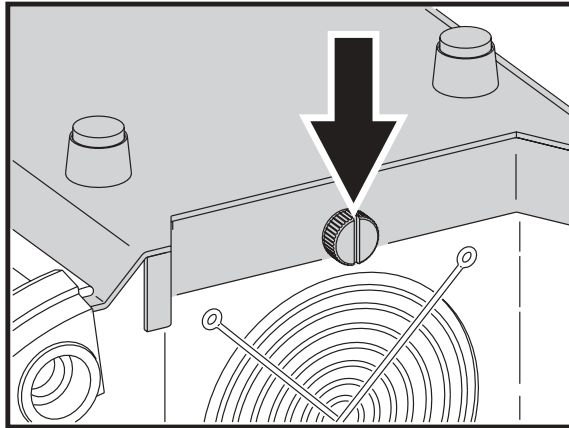

3. Slide the fixture cover open.
4. Vacuum or gently blow away dust and loose particles with compressed air.
5. Remove stuck particles with an unscented tissue or cotton swab moistened with glass cleaner or distilled water. Do not rub the surface: lift the particles off with a soft repeated press.
6. Remove smoke, and other, residues with cotton swabs or unscented tissues moistened with isopropyl alcohol. A commercial glass cleaner may be used, but residues must be removed with distilled water. Clean with a slow circular motion from center to edge. Dry with a clean, soft and lint-free cloth or compressed air.
7. Close the fixture cover and tighten the thumb screw, taking care not to trap any wires.

## LAMP MAINTENANCE

---

**Warning** *Isolate from power supply before re-lamping. The lamp must be changed if it becomes damaged or thermally deformed.*

**Caution** *Hot lamp.*

**Important** *The Mania DC3 is supplied with a Philips 6958 24V 250W 10H lamp (Martin P/N 97000115) with an average life of 1000 hours. The fixture must only be used with this lamp. Using any other lamp type may damage the fixture and will invalidate the product warranty.*

## Installing a lamp in the Mania DC3

1. Disconnect the fixture from power and allow it to cool for 20 minutes.
2. Remove the thumb screw holding the cover in place.

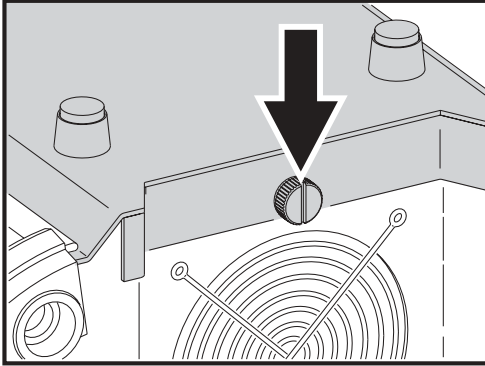

3. Slide the fixture cover open.
4. Holding the bulb as close to the base as possible, pull it out of the bulb socket with a gentle rocking motion.

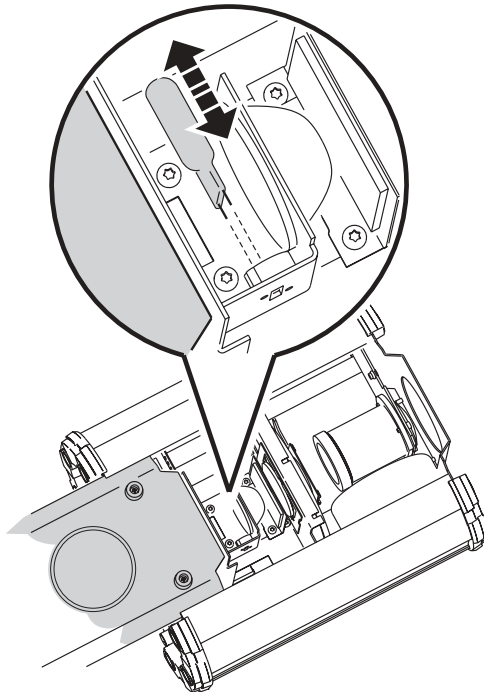



5. Replace the bulb. Use only a Philips 6958 24V 250W 10H lamp (Martin P/N 97000115).
6. Close the fixture cover and tighten the thumb screw, taking care not to trap any wires.
7. Reapply power to the fixture.

## INSTALLING AN OIL WHEEL

---

The Mania DC3 is supplied with a multi-colored oil wheel. Other color variants are available.

To install the oil wheel:

1. Disconnect the fixture from power and allow it to cool for 20 minutes if it has been in use.
2. Remove the two oil wheel cover retaining screws and remove the cover.

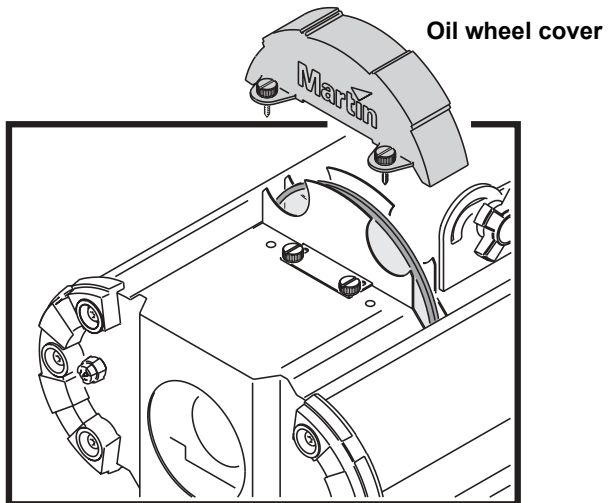

3. Turn the fixture over and remove the thumb screw holding the fixture cover in place.

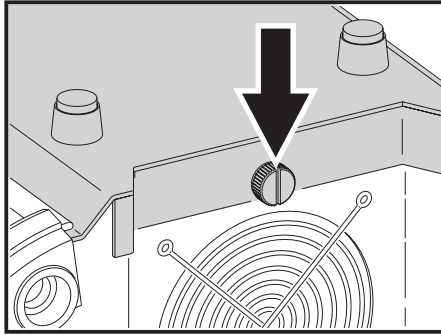

4. Slide the fixture cover open and place the fixture on its side.

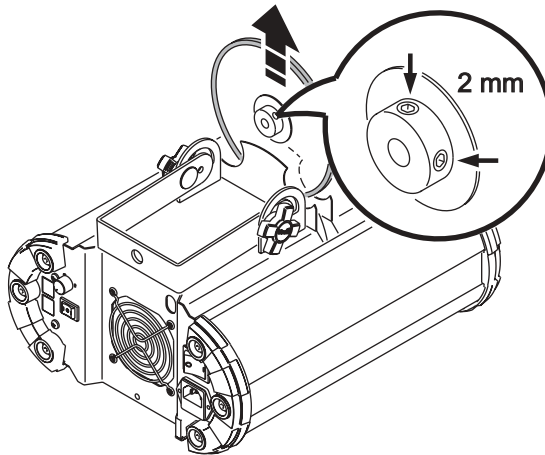

5. If you have previously installed an oil wheel, remove it by loosening the two grub screws in the oil wheel hub by approx. one full turn, sliding the oil wheel off its spindle and withdrawing it through the housing as illustrated above. Only loosen the grub screws enough to unclamp the oil wheel from its spindle (approx. one full turn).
6. Pass the new oil wheel carefully through the aperture in the housing and slide it onto its spindle. Pass one hand through the bottom of the fixture and hold the oil wheel to support it, if necessary.
7. Use the 2mm Allen key supplied with the Mania DC3 to tighten the two grub screws in the oil wheel hub and clamp the oil wheel in place on its spindle. Check that the oil wheel is firmly attached and rotates without fouling any other components.
8. Replace all covers, before reapplying power.

The color pigments in oil wheels gradually fade with time. For best color reproduction, it is recommended that you replace the oil wheel with a new item after approximately 1000 hours of service. Since the average life of the lamp is also 1000 hours, it is a good idea to change both lamp and oil wheel as a set.

## INSTALLING A GOBO OR FILTER

---

The Mania DC3 can be fitted with either:

- a size D gobo with a maximum image diameter of 38 mm (1.5 in.), or
- a colored or textured glass filter

Interesting effects can be achieved when either of these effects is used in combination with the oil wheel. Using a gobo, the oil wheel can fill an image or logo, for example, with constantly changing color patterns. A colored glass filter can strengthen color and reduce light intensity, giving a more intimate atmosphere.

To install a gobo or filter:

1. Disconnect the fixture from power and allow it to cool for 20 minutes.
2. Remove the two oil wheel cover retaining screws and remove the cover to reveal the gobo access hatch.

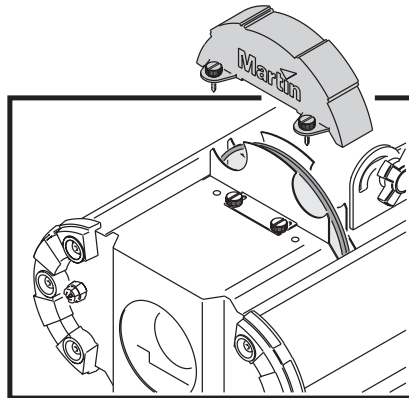

3. Remove the two gobo holder retaining screws and carefully lift the gobo holder up and out of the fixture.

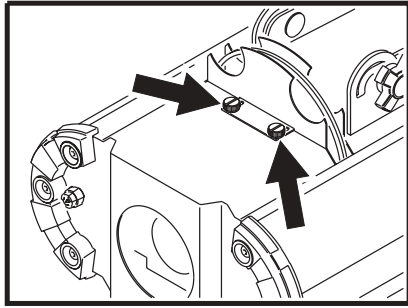

4. Slide the gobo or glass filter into the steel clip in the gobo holder. Note that for correct focus, the coated side of the gobo or filter should face the lamp.

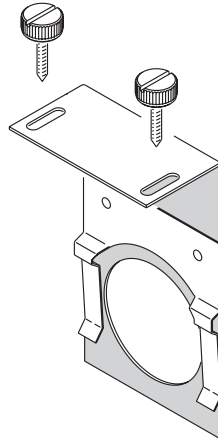

5. Replace the gobo holder and oil wheel cover, before reapplying power.

## RECONFIGURING THE BEAM

---

The Mania DC3 is supplied with an adjustable lens module allowing the beam angle to be set to either 25° or 32°. A 43° beam angle converter is also available from your Martin dealer as an accessory.

The lens is factory-set to 25°, but this can be changed to 32° as follows.

You will need the 2mm Allen key supplied with the Mania DC3 for this operation.

To reconfigure the lens:

1. Disconnect the fixture from power and allow it to cool for 20 minutes.

2. Turn the fixture over and remove the thumb screw holding the cover in place.

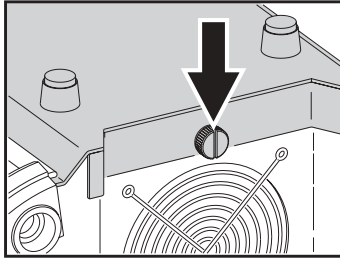

3. Slide the fixture cover open.
4. Turn the focus knob clockwise as far as it will go. This will move the lens module towards the front of the fixture, giving enough space to remove the lens module.

5. The lens module has a bayonet-type fitting. Working through the front aperture of the fixture, loosen – but do not remove – the three 2mm Allen bolts around the lens.

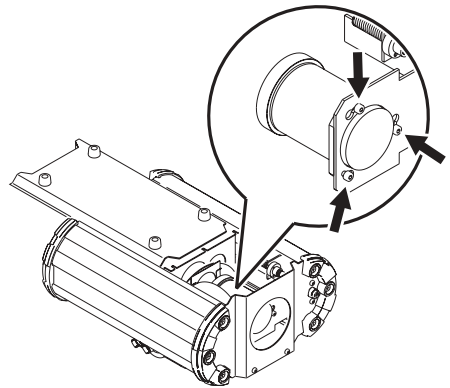

6. Working inside the fixture, grasp the lens module and twist it counterclockwise so that it is released from the mounting screws. Lift the lens module out of the fixture.

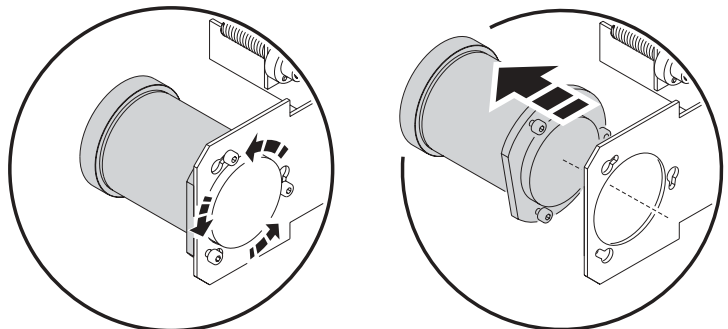

7. Prepare a soft cloth or similar device to catch components if they fall out of the lens module.
8. See illustration below. Open the lens module by unscrewing the retaining ring (D). To obtain a 32° beam angle, remove the concave lens (C) and thin spacer (B). Insert the thick spacer (E) supplied with the fixture and retighten the retaining ring (D).

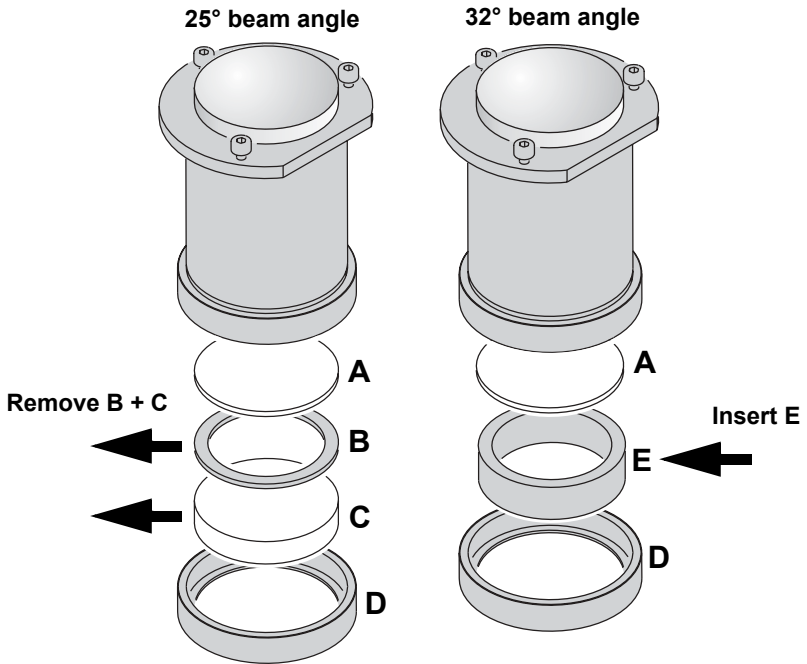

9. Retain components B and C for possible future use.

## LENS ASSEMBLY

---

When you open the Mania DC3 lens module, you may find out the hard way that it is easy to mix up the lenses. To reassemble the lenses correctly, see the illustration on the right and remember that:

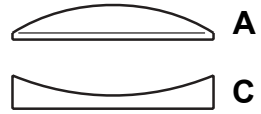

- The flat surfaces must face towards the lamp
- The concave lens (C) must be placed closest to the lamp, and the convex lens (A) furthest away from the lamp.



## REPLACING THE MAINS FUSE

---

The Mania DC3 uses a time-delay fuse for protection against current overload. An indication that the fuse may have blown is that when power is applied and the lamp is switched on, no light is produced.

If the fuse blows repeatedly, there is a fault with the unit that requires service by a Martin technician.

Never bypass the fuse or replace it with one of another size or rating.

1. Unplug the mains cable from the input socket.
2. Pry open the fuse holder (located next to the mains power connector) with a flat-head screwdriver and remove the fuse.

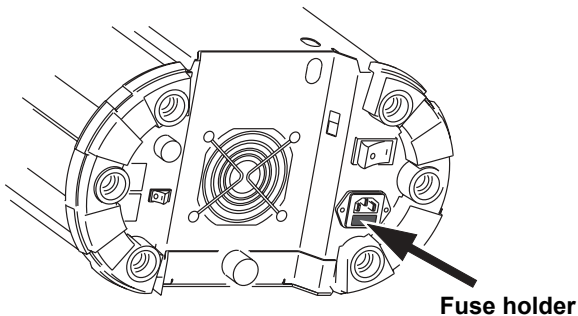

3. Replace the fuse with one of the same type. The fuse rating is listed on the serial number label and in "Specifications" on page 25.
4. Replace the fuse holder.

# TROUBLESHOOTING

# 5

<b>Problem</b>	<b>Probable cause(s)</b>	<b>Suggested remedy</b>
No light	No power to the fixture	Check connections
	Blown fuse	If power is applied and the lamp is switched on, but does not light, then check and replace fuse if necessary.
	Burned out lamp	Install new lamp
	Fixture too hot	Allow to cool Improve air flow around fixture
No action	Electrical malfunction	Refer to a Martin service technician
Fuse blows repeatedly	Electrical malfunction	Refer to a Martin service technician



# SPECIFICATIONS

## PHYSICAL

Size without mounting bracket (LxWxH) . . .340x290x215 mm (13.4x11.4x8.5 in.)  
Weight. . . . .9 kg (19.8 lbs)

## CONSTRUCTION

Housing. . . . . steel and aluminum

## THERMAL

Exterior surface temperature under steady state condition . . . . .95°C (203°F)  
Time required to cool before handling . . . . . at least 20 minutes  
Maximum ambient temperature ( $T_a$ ) . . . . . 40° C (104°F)

## INSTALLATION

Minimum distance to flammable material . . . . .0.3 m (1ft)  
Minimum distance to illuminated surface . . . . . 1.0 m (3.3ft)  
Minimum clearance around air vents . . . . . 0.1 m (4in)

## CONTROL

Oil wheel direction . . . . . reversible via control panel and/or remote  
Oil wheel rotation speed . . . . . adjustable via control panel and/or remote  
Remote control unit. . . . 4 fixture control with up to 10 m (16 ft) between fixtures

## GOBO

Size. . . . .D  
Maximum image diameter . . . . . 38 mm (1.5 in.)

## COLOR/TEXTURE FILTERS

Size. . . . . Circular 53.3mm (2.1 in.)  
Thickness . . . . . 1.1-2 mm (0.05-0.08 in.)

## PHOTOMETRICS

Beam angle. . . . .25°, configurable to 32°. Also 43° option.

## ELECTRICAL

Input . . . . . 3-prong IEC male socket  
AC Power switch selectable, operating ranges 115-120 V / 220-240 V, 50-60 Hz  
Main fuse . . . . .3.15 AT (time delay), P/N 05020013

## TYPICAL POWER AND CURRENT

115 V, 50 Hz	.265 W, 2.3 A
115 V, 60 Hz	.262 W, 2.3 A
120 V, 50 Hz	.284 W, 2.3 A
120 V, 60 Hz	.281 W, 2.3 A
220 V, 50 Hz	.247 W, 1.1 A
220 V, 60 Hz	.244 W, 1.1 A
230 V, 50 Hz	.265 W, 1.1 A
230 V, 60 Hz	.263 W, 1.1 A
240 V, 50 Hz	.284 W, 1.2 A
240 V, 60 Hz	.282 W, 1.2 A

## INCLUDED ITEMS - US VERSION

2 m (6.5 ft) US mains cable 18AWG with US male connector (UL approved)  
Lamp: Philips 6958 24V 250W 10H (average life 1000 hrs.) . . . . . P/N 97000115  
Multi-colored oil wheel  
User manual  
Remote control with 5 m (16.4 ft) RJ-45 cable  
2mm Allen key  
White glove with Martin logo

## INCLUDED ITEMS - NON-US VERSION

3 m (9.8 ft) EU mains cable 3x1.0mm<sup>2</sup> with Schuko male connector  
3 m (9.8 ft) EU mains cable 3x1.0mm<sup>2</sup> with no male connector  
Lamp: Philips 6958 24V 250W 10H (average life 1000 hrs.) . . . . . P/N 97000115  
Multi-colored oil wheel  
User manual  
Remote control with 5 m (16.4 ft) RJ-45 cable  
2mm Allen key  
White glove with Martin logo

## ACCESSORIES

Philips 6958 24V 250W 10H lamp (average life 1000 hrs).. . . . . P/N 97000115  
Half-coupler clamp . . . . . P/N 91602005  
3.15 AT fuse . . . . . P/N 05020013  
UTP patch cable 5 m (16.4 ft) RJ-45. . . . . P/N 11840095  
White glove with Martin logo . . . . . P/N 50590002  
43° beam angle converter

## ORDERING INFORMATION

Mania DC3, 220-240v . . . . . P/N 90430070  
Mania DC3, 115-120v . . . . . P/N 90430071



---

[www.martin.com](http://www.martin.com) • Olof Palmes Allé 18 • 8200 Aarhus N • Denmark  
Tel: +45 8740 0000 • Fax +45 8740 0010