

VC-G50 Camera

Installation Guide – English

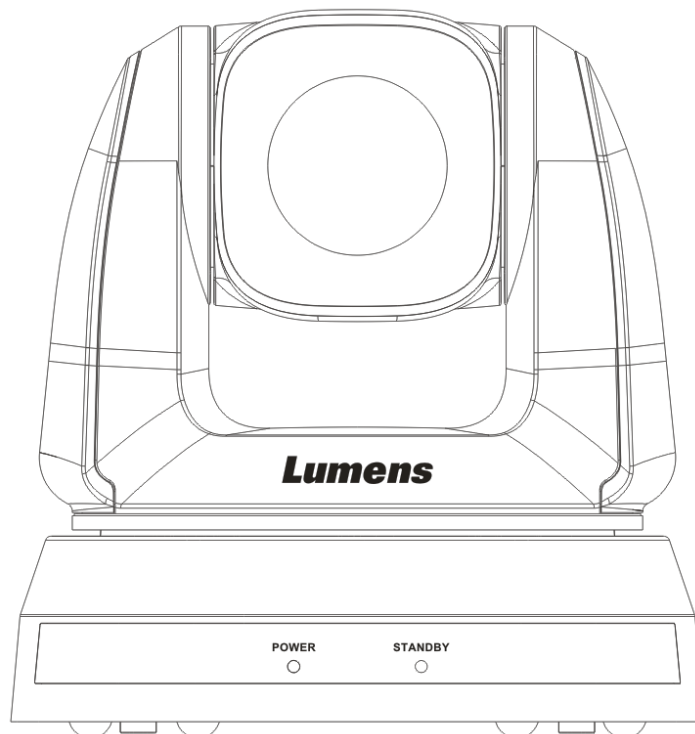

[Important]

To download the latest version of Quick Start Guide, multilingual user manual, software, or driver, etc., please visit Lumens

<http://www.Mylumens.com>

Table of Contents

| | |
|--|-----------|
| Copyright Information | 3 |
| Chapter 1 Safety Instructions | 4 |
| Precautions | 5 |
| FCC Warning | 5 |
| EN55022 (CE Radiation) Warning | 5 |
| KCC Warning | 6 |
| Chapter 2 Package Contents | 7 |
| Chapter 3 Product Overview | 8 |
| 3.1 Overview..... | 8 |
| 3.2 Description of LED indicator | 8 |
| Chapter 4 Instruction for installation | 9 |
| 4.1 Preparation before installation | 9 |
| 4.2 Instruction for installation | 9 |
| 4.3 Connecting the device | 18 |
| Chapter 5 Remote Control and Setting Menu | 21 |
| 5.1 Functions of remote control | 21 |
| 5.2 Setting menu | 22 |
| Chapter 6 Descriptions of Major Functions | 30 |
| 6.1 I would like to switch to VC-G50 | 30 |
| 6.2 I would like to save the current lens position data | 30 |
| 6.3 I would like to clear the saved position data | 30 |
| 6.4 I would like to turn on the back light compensation function | 30 |
| 6.5 I would like to adjust the shooting angle of the lens | 30 |
| 6.6 I would like to zoom in/out images | 30 |

| | | |
|---|---|-----------|
| 6.7 | I would like to adjust the focal length | 31 |
| 6.8 | I would like to adjust the focus speed | 31 |
| 6.9 | I would like to set the image mode..... | 32 |
| 6.10 | I would like to freeze images..... | 32 |
| 6.11 | I would like to rotate the image | 32 |
| 6.12 | I would like to change the camera direction | 32 |
| 6.13 | I would like to display the current status | 32 |
| Chapter 7 DIP Switch Setting | | 33 |
| 7.1 | DIP SWITCH..... | 33 |
| 7.2 | RS-422 Connection | 35 |
| Chapter 8 Troubleshooting..... | | 37 |

Copyright Information

Copyrights © Lumens Digital Optics Inc. All rights reserved.

Lumens is a trademark that is currently being registered by Lumens Digital Optics Inc.

Copying, reproducing or transmitting this file is not allowed if a license is not provided by Lumens Digital Optics Inc. unless copying this file is for the purpose of backup after purchasing this product.

In order to keep improving the product, Lumens Digital Optics Inc. hereby reserves the right to make changes to product specifications without prior notice. The information in this file is subject to change without prior notice.

To fully explain or describe how this product should be used, this manual may refer to names of other products or companies without any intention of infringement.

Disclaimer of warranties: Lumens Digital Optics Inc. is neither responsible for any possible technological, editorial errors or omissions, nor responsible for any incidental or related damages arising from providing this file, using, or operating this product.

Chapter 1 Safety Instructions

Always follow these safety instructions when setting up and using the Camera:



1. Use attachments only as recommended.
2. Use the type of power source indicated on the Camera. If you are not sure of the type of power available, consult your distributor or local electricity company for advice.
3. Always take the following precautions when handling the plug. Failure to do so may result in sparks or fire.
 - Ensure the plug is free of dust before inserting it into a socket.
 - Ensure that the plug is inserted into the socket securely.
4. Do not overload wall sockets, extensions leads or multi-way plug boards as this may cause fire or electric shock.
5. Do not place the Camera where the cord can be stepped on as this may result in fraying or damage to the lead or the plug.
6. Do not block the slots and openings in the case of Camera. They provide ventilation and prevent the Camera from overheating. Do not place the Camera on the soft surface of sofas, carpets or others.
7. Never push objects of any kind through cabinet slots. Never allow liquid of any kind to spill into the Camera.
8. Except as specifically instructed in this User Manual, do not attempt to operate this product by yourself. Opening or removing covers may expose you to dangerous voltages and other hazards. Refer all servicing to licensed service personnel.
9. Unplug the Camera during thunderstorms or if it is not going to be used for an extended period. Do not place the Camera or remote control on top of vibrating equipment or heated objects such as a car, etc.
10. Unplug the Camera from the wall outlet and refer servicing to licensed service personnel when the following situations happen:
 - If the power cable or plug becomes damaged or frayed.
 - If the camera is wet with liquid, rain or water.

<Note> Using an incorrect battery type in the remote control may result in breakdown. Follow local instructions on how to dispose of used batteries.

■ Precautions

Warning: To reduce the risk of fire or electric shock, do not expose this appliance to rain or moisture.

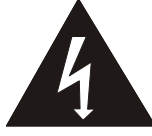
If Camera will not be used for an extended time, unplug it from the power socket.

| | | | | |
|---|---|---|--|---|
|  | <table border="1"> <tr> <td style="text-align: center;">Note</td> </tr> <tr> <td style="text-align: center;">Risk of Electric Shock DO NOT OPEN</td> </tr> </table> | Note | Risk of Electric Shock DO NOT OPEN |  |
| Note | | | | |
| Risk of Electric Shock DO NOT OPEN | | | | |
| <p>Caution: To reduce the risk of electric shock, do not remove cover (or back). No user-serviceable parts inside. Refer servicing to licensed service personnel.</p> | | | | |
|  | <p>This symbol indicates that this equipment may contain dangerous voltage which could cause electric shock.</p> |  | <p>This symbol indicates that there are important operating and maintenance instructions in this User Manual with this unit.</p> | |

■ FCC Warning

This Camera has been tested and found to comply with the limits for a Class A digital device, pursuant to Article 15-J of FCC Rules. These limits are designed to provide reasonable protection against harmful interference in a commercial installation.

This digital apparatus does not exceed the Class A limits for radio noise emissions from digital apparatus as set out in the interference-causing equipment standard entitled "Digital Apparatus," ICES-003 of Industry Canada.

Cet appareil numérique respecte les limites de bruits radioélectriques applicables aux appareils numériques de Classe A prescrites dans la norme sur le matériel brouilleur: "Appareils Numériques," NMB-003 édictée par l'Industrie.

■ EN55022 (CE Radiation) Warning

This product is intended for use in a commercial, industrial, or educational environment. It is not intended for residential use.

This is a Class A product. In a residential environment it may cause radio interference, in which case the user may be required to take adequate measures. The typical use is in a conference room, reception room or hall.

■ KCC Warning

| | |
|-------------------------|---|
| A 급 기기 (업무용 방송통신기자재) | 이 기기는 업무용(A 급) 전자파적합기기로서 판매자 또는 사용자는 이 점을 주의하시기 바라며, 가정 외의 지역에서 사용하는 것을 목적으로 합니다. |
|-------------------------|---|

Chapter 2 Package Contents

VC-G50



Instruction for
installation



Remote Control



Power Cord

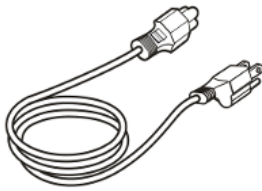

Appearance may vary
depending on
country/region

Power Adapter

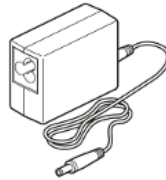

RS-422 Connector

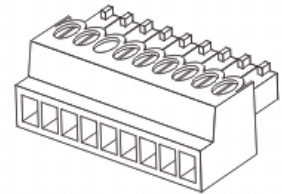

Metal Plate A

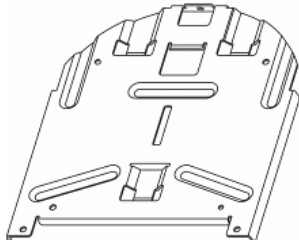

Metal Plate B

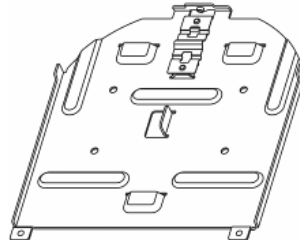

M3 Screws

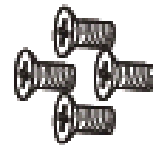

Chapter 3 Product Overview

3.1 Overview

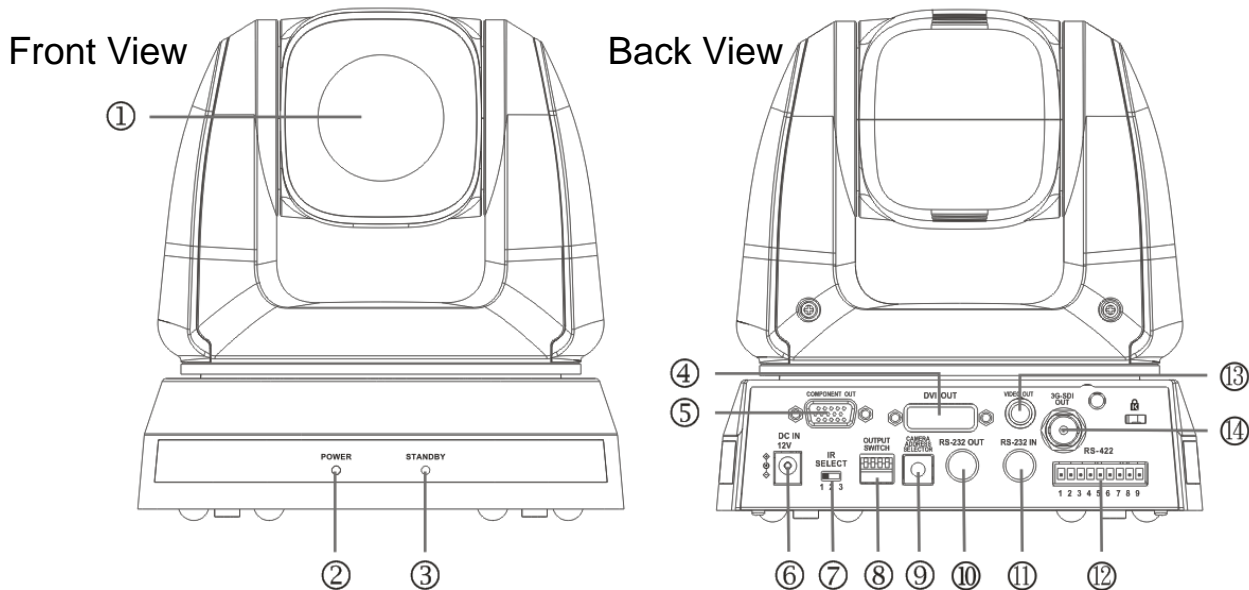

| | |
|-----------------------------|------------------------|
| 1. Camera lens | 2. Power LED indicator |
| 3. Standby LED indicator | 4. DVI output |
| 5. Component output | 6. Power input |
| 7. IR SELECT | 8. OUTPUT Switch |
| 9. Camera Address Selectors | 10. RS-232 output |
| 11. RS-232 input | 12. RS-422 connection |
| 13. VIDEO output | 14. 3G-SDI output |

3.2 Description of LED indicator

3.2.1 Power :

3.2.1.1 No light: Power off

3.2.1.2 Green light: In use

3.2.1.3 Flickering green: Signal from the remote control is received;
the indicator flickers every 0.5 second

3.2.2 Standby :

3.2.2.1 Orange: In standby mode

3.2.2.2 No light: Power on

Chapter 4 Instruction for installation

4.1 Preparation before installation

Installation and connection of VC-G50 Camera requires special skills. To install by yourself, please follow necessary steps, ensure steady and tight installation of the device, and pay attention to your safety to avoid any accident.

4.1.1 Ensure the safety of the installation environment. Please do not install the device on unstable ceiling or in a place where the device is in danger of falling to avoid any accident.

4.1.2 Please check whether accessories in the box are complete or not. Please contact the supplier for any shortage, and make sure to keep the accessories in the box intact.

4.1.3 Please choose a proper place for installation of VC-G50 in advance. Please determine an installation place according to the following requirements:

4.1.3.1 Confirm the position for the object to be captured.

4.1.3.2 Confirm whether the VC-G50 is set at a proper distance from other light sources.

4.2 Instruction for installation

4.2.1 I would like to install VC-G50 on the desk

4.2.1.1 Precautions for installation

- ◆ Please install the machine on a flat desk
- ◆ Do not grab the camera head by hand when handling the device
- ◆ Do not rotate the camera head by hand. Improper rotation may result in breakdown of the camera

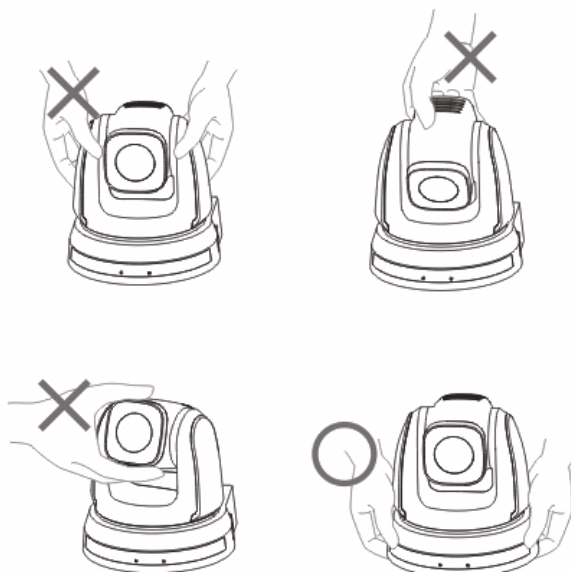

4.2.1.2 Installation steps

1. Please adjust DIP switch at first prior to installation.

<Remark> Please refer to [Chapter 7 DIP Switch Setting](#) for the relevant descriptions on DIP switch.

2. Place the camera on a flat desk directly to ensure the normal vertical and horizontal operation of the machine.

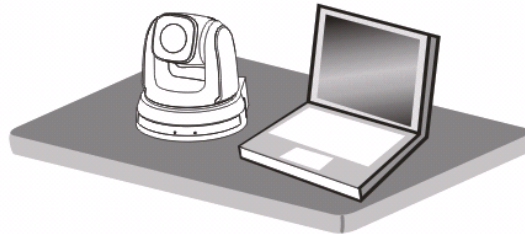

4.2.2 I would like to install VC-G50 on the ceiling

4.2.2.1 Prepare for the parts and equipment required during the installation

1. Accessories of VC-G50 in the box (metal plates A, B and M3 screw x 7)
2. Screw for locking on ceiling mounted hanger x 4
3. Drilling machine, screw driver, ladder

4.2.2.2 Dimension

Length x Width x Height : 174x186x182.7mm

Weight : 2.0Kg

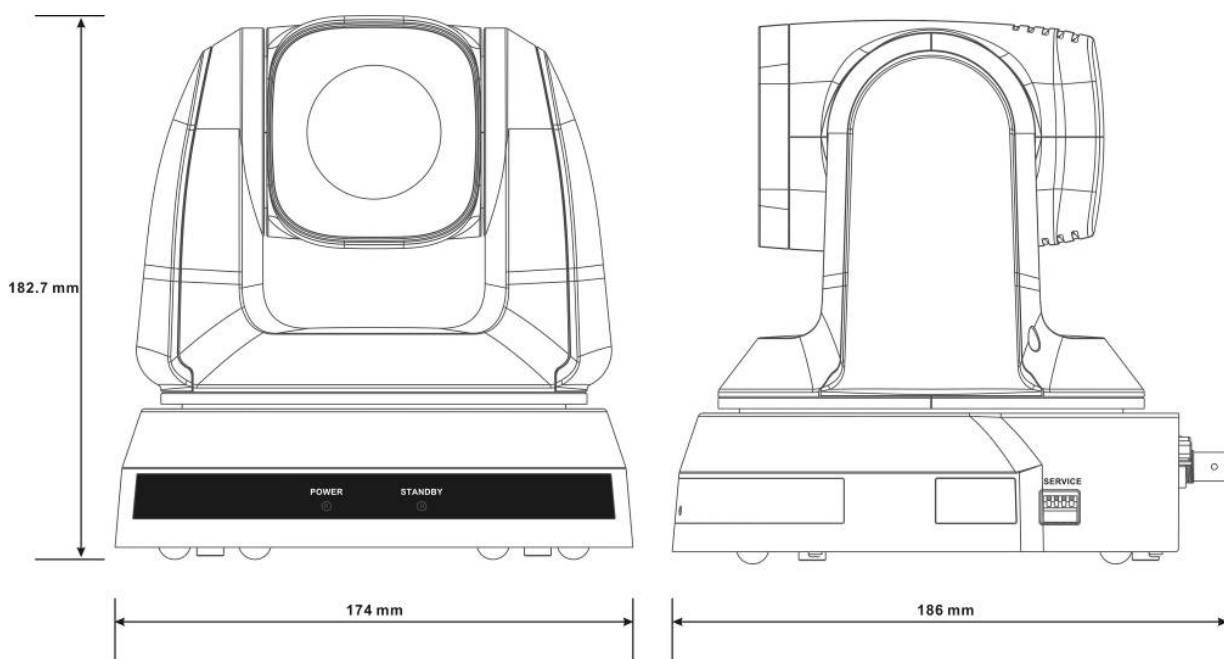

4.2.2.3 Max. rotation dimension of camera

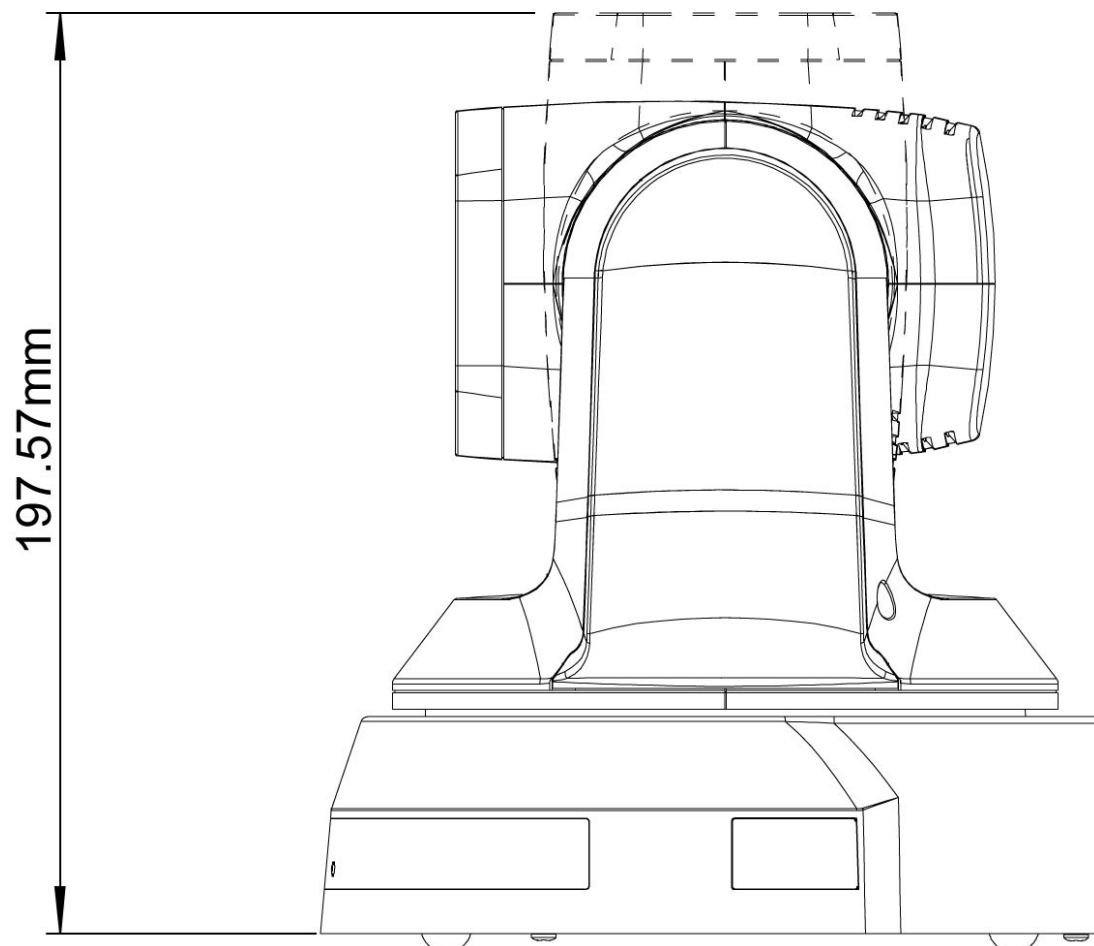

4.2.2.4 Size Diagram

1. Metal plate B - ceiling side

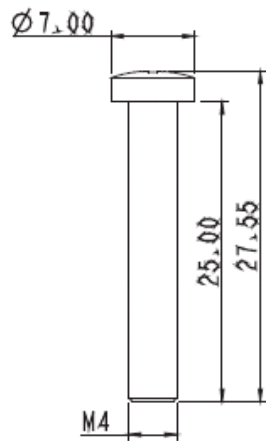

Metal plate B locking screw

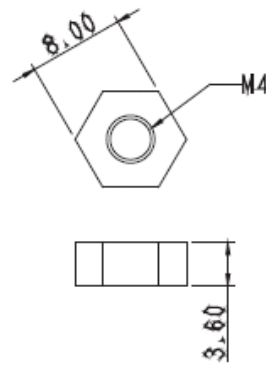

Metal plate B locking bolt

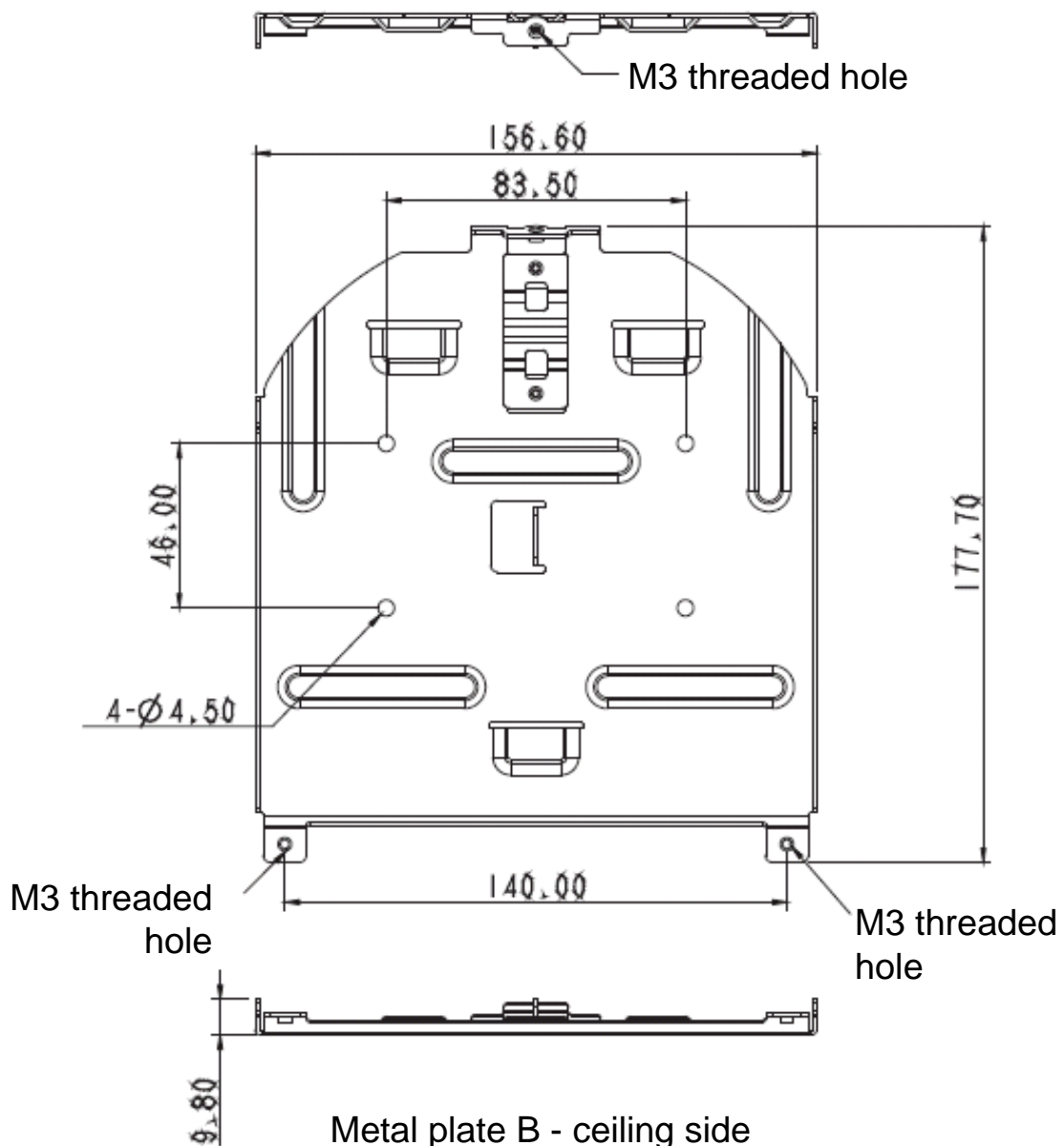

Metal plate B - ceiling side

2. Metal plate A - machine side

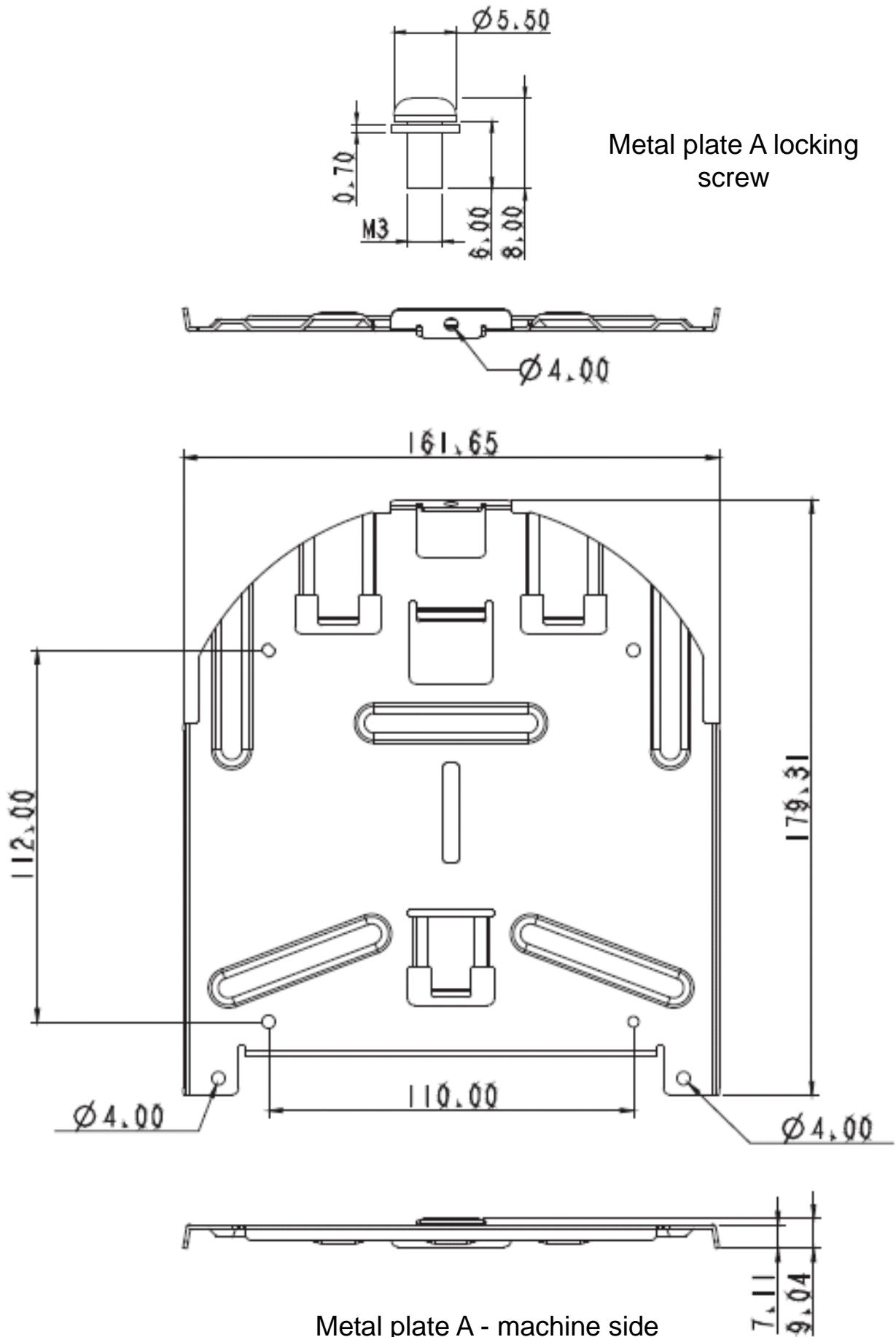

3. Bottom of machine

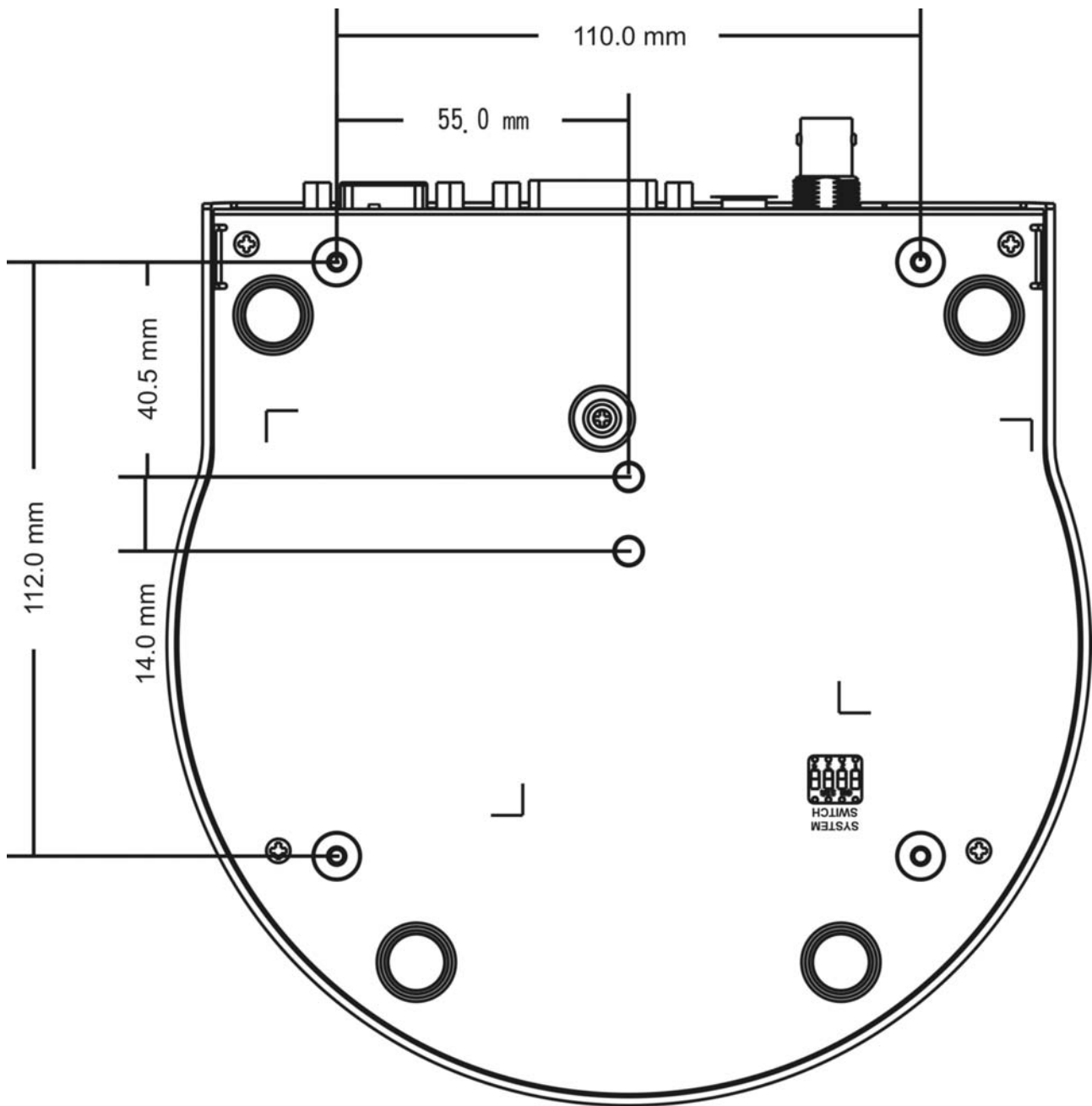

4.2.2.5 Precautions for installation

1. Before installation, please confirm the orientation of the machine relative to the object to be captured
2. It is recommended that the machine should be set at a distance of more than 1 meter away from the object to be captured.
Please adjust for a best distance according to the magnification of the lens

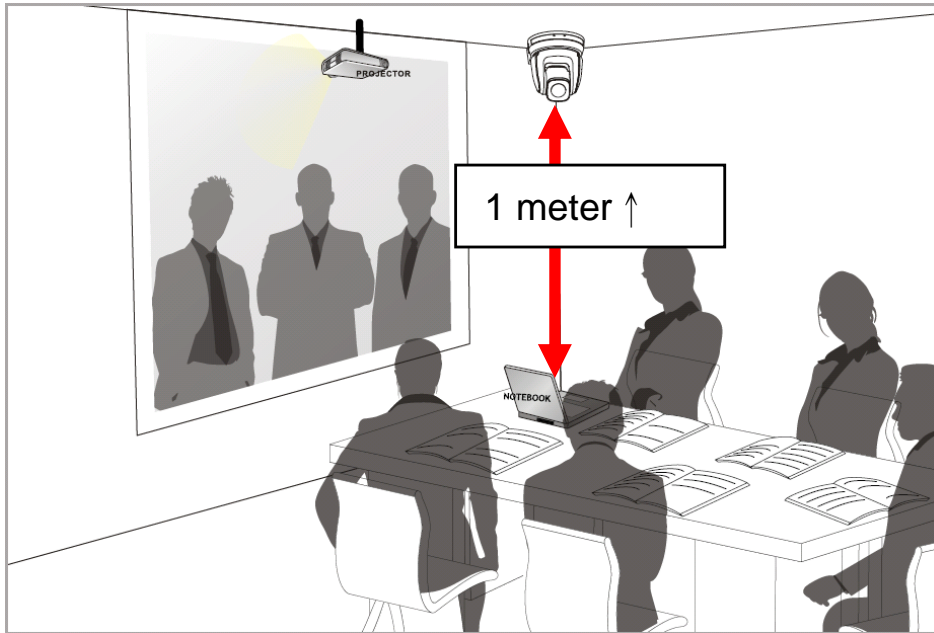

3. The machine (including metal plates) is weighed at about 2.5 kg. If it is to be installed on the ceiling, please use the hanger that has obtained UL security approval to prevent the machine from falling down.
4. Please check whether the camera is installed securely on a regular basis

4.2.2.6 Installation steps

1. Please adjust resolution on DIP switch at first
<Remark> Please refer to [Chapter 7 DIP Switch Setting](#) for the relevant descriptions on DIP switch.
2. Fix the metal plate A on the machine base with 4 M3 screws.

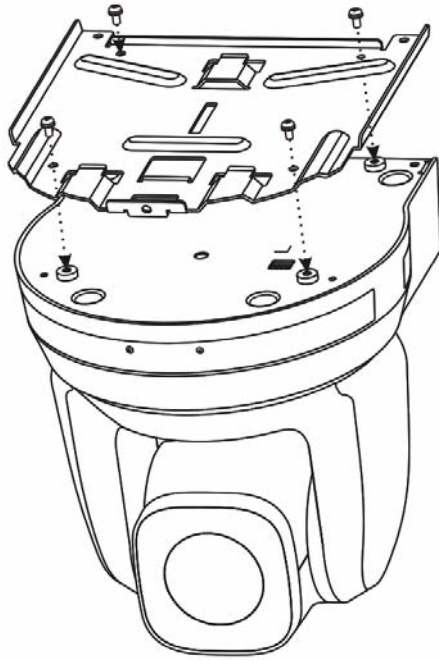

3. Lock the metal plate B on ceiling mounted hanger.

※Caution:

- (1) Please use the hanger that has obtained UL security approval
- (2) Please reserve the hole for the connecting wires of the camera

4. Combine the metal plate A and the metal plate B

- (1) Push the metal plate A up to the ceiling and then to the right to latch the metal plate B
- (2) Fix with 3 M3 screws

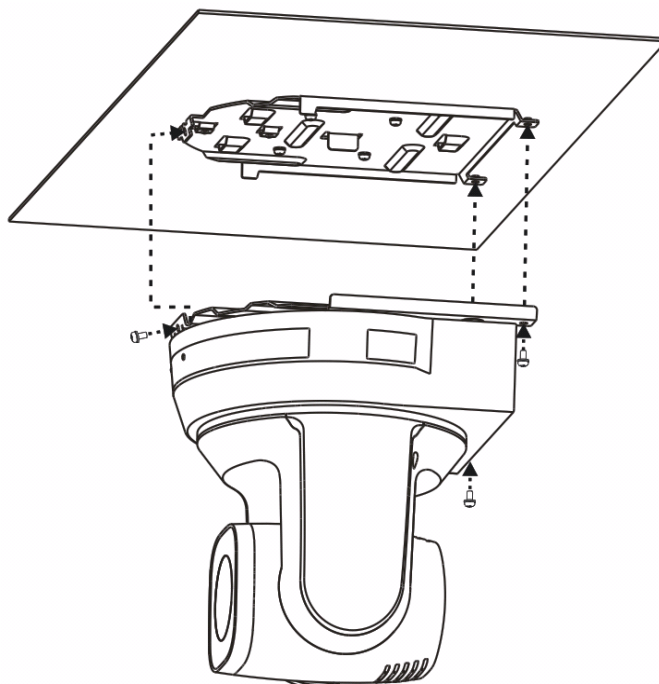

4.2.2.7 How to remove

1. Remove the connecting wires from the camera
2. Uninstall the camera together with the ceiling, loosen the three screws that fix the metal plates A and B and push to the left to remove the machine

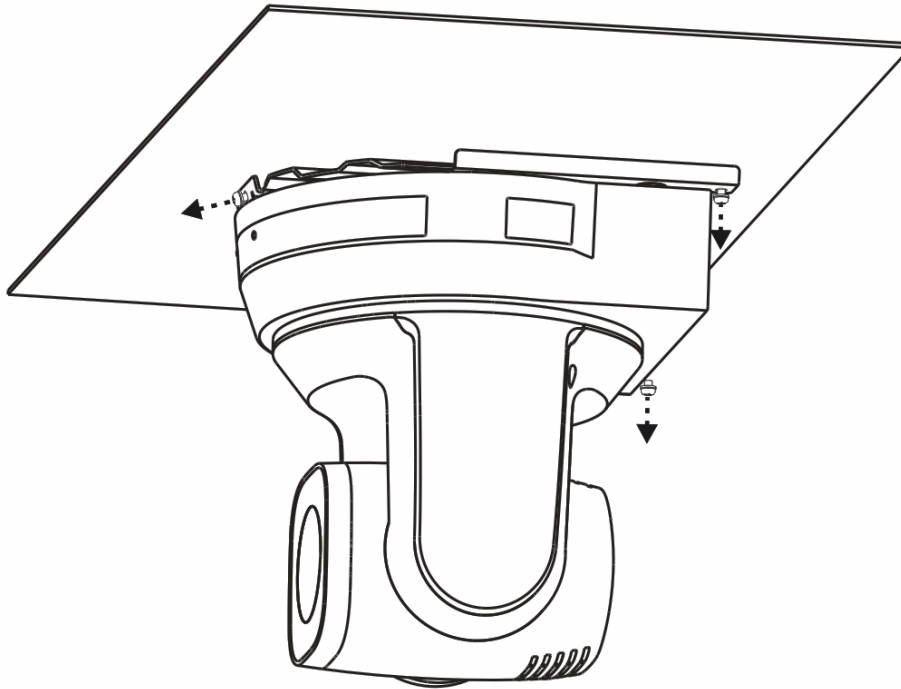

3. Then remove the screws on the hanger and the machine

4.3 Connecting the device

4.3.1 Image output

4.3.1.1 Connecting to a HDTV/computer monitor (DVI)

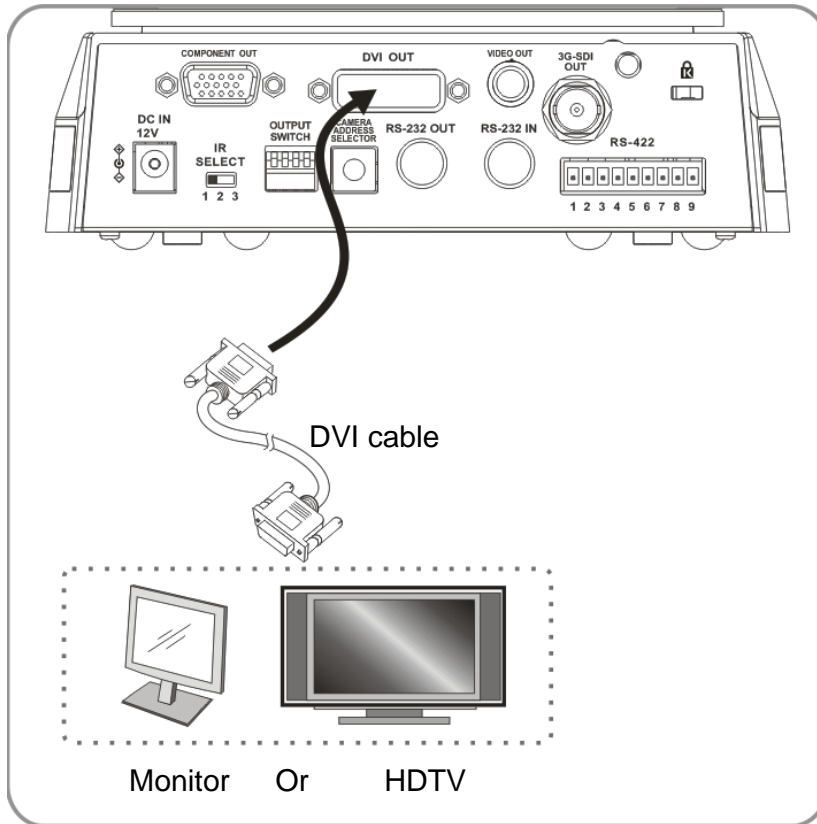

4.3.1.2 Connecting to a TV (C-Video)

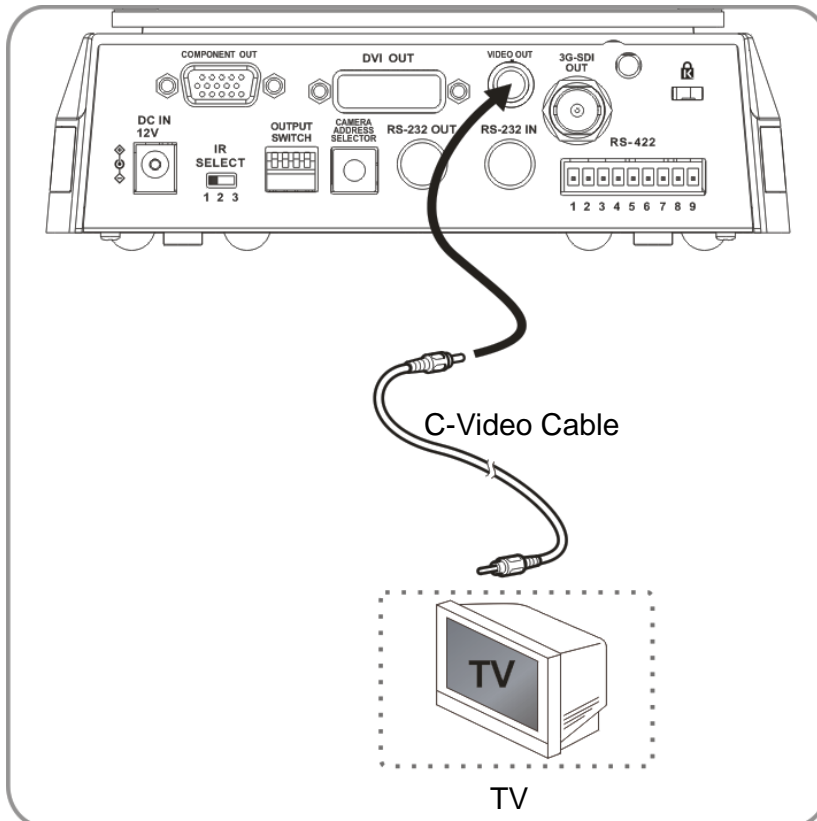

4.3.1.3 Connecting to a HDTV (3G-SDI)

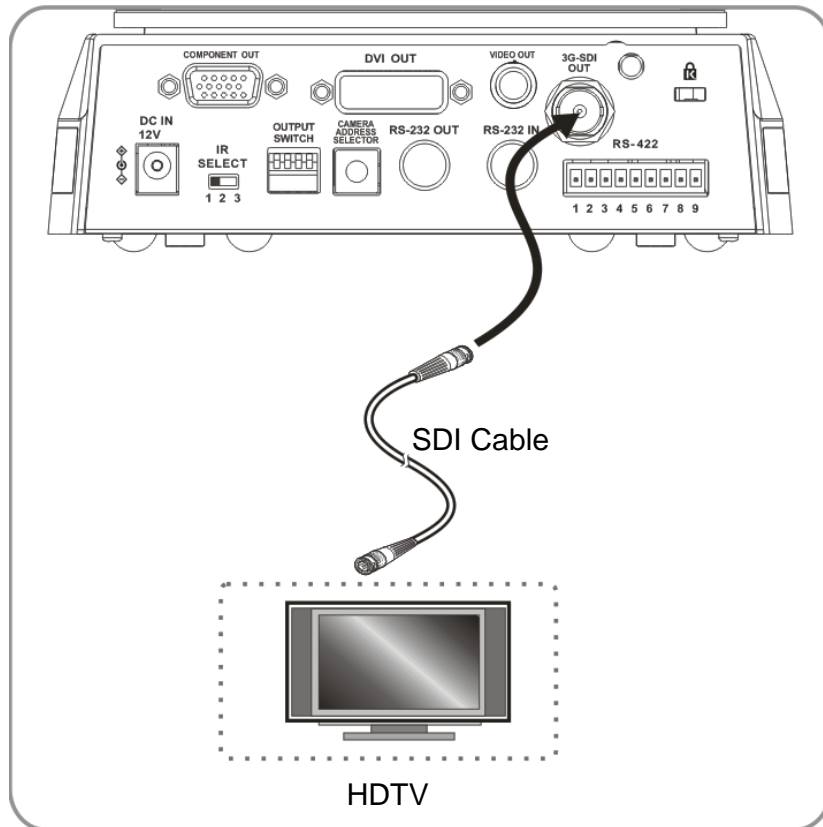

4.3.1.4 Connection to the device for image output

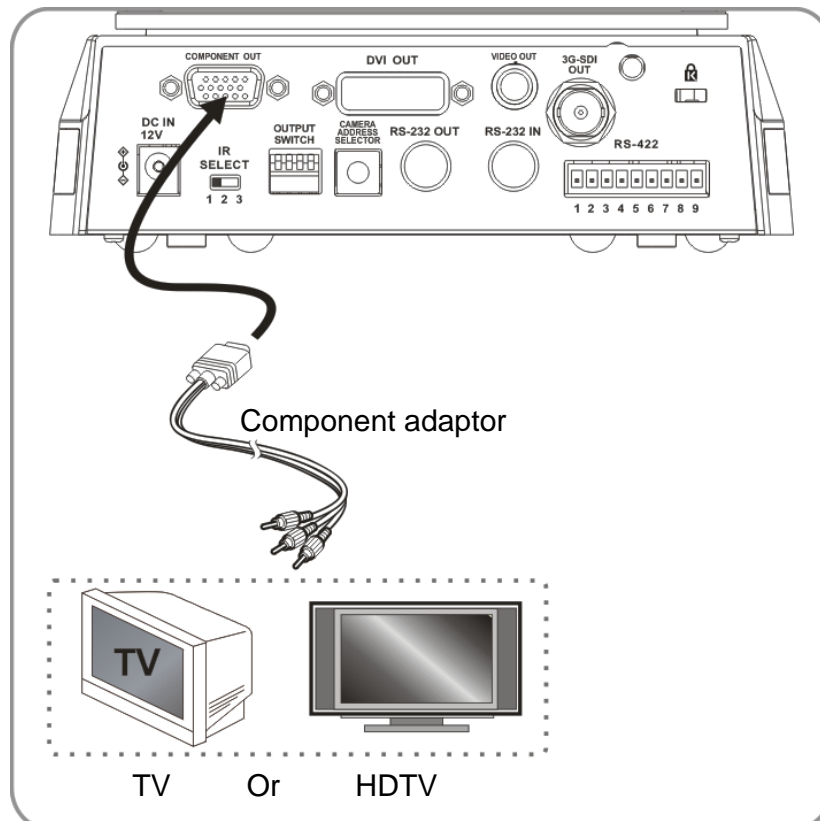

4.3.2 Controlling VCs with the computer

4.3.2.1 Connecting to one computer for connection between VCs (RS-232 in/out)

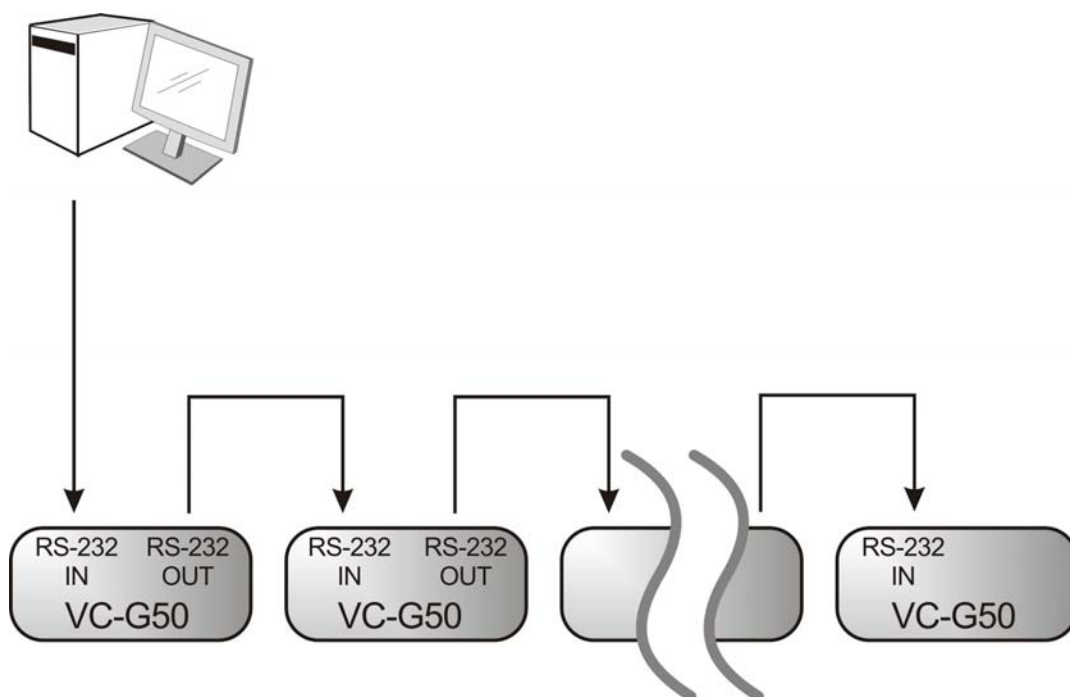

<Remark> With RS-232 in/out, at most 7 VCs can be connected.

4.3.2.2 Connecting to one computer for connection between VCs (RS-422)

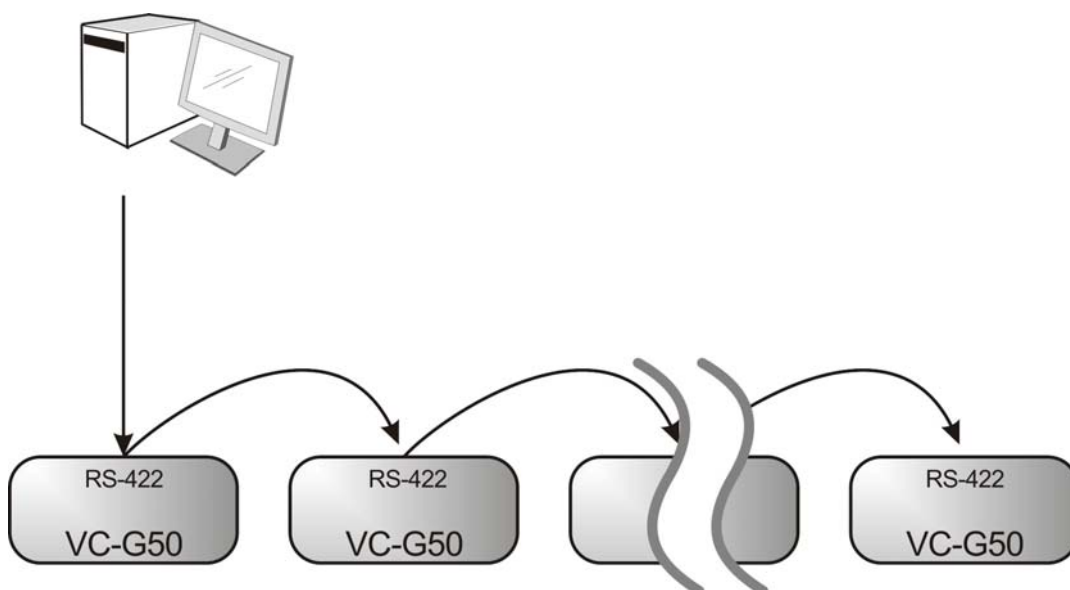

<Remark> Please refer to [7.2 RS-422 connection](#) for the RS-422 connection instructions.

<Remark> With RS-422, at most 7 VCs can be connected.

Chapter 5 Remote Control and Setting Menu

5.1 Functions of remote control

<Remark> The below functions are listed alphabetically.

| Item | Description |
|-------------------------|---|
| ◀, ▶, ▲, ▼ | Move the lens |
| Back Light | Turn on/off back light compensation |
| Camera select | Select 1~3 VC-G50 |
| Focus-Manual / Far/Near | Turn on manual focus to adjust the focal length |
| Focus-Auto | Auto focus |
| Freeze | Freeze the screen |
| Home-Enter | Go back to the main page/Execute |
| Info | Status information |
| L/R Direction Set | L/R Direction / Off / Normal |
| Menu | Display OSD menu |
| Mirror | Rotate the image (Off/ Mirror/ Flip/ Mirror+Flip)) |
| Pan/Tilt Reset | Clear the Pan/Tilt setting |
| Picture | Switch image effect (Off / Neg / B&W) |
| Power | Power switch |
| Preset | Appoint an ID (0 ~ 9) to save the current position data |
| Reset | Appoint an ID (0 ~ 9) to delete the current position data |
| Zoom-Fast | Adjust image size |
| Zoom-Slow | Fine-tune image size |

5.2 Setting menu

<Remark> Press [Menu] on the **remote control** to enter the setting menu; the **bold underlined** values in the following table are defaults.

| 1 st Level Major Items | 2 nd Level Minor Items | 3 rd Level Adjustment Values | | Function Descriptions | |
|---|--------------------------------------|--|------------|---|--------------------------|
| Exposure | Mode | 1. <u>Full Auto</u> 2. Shutter Pri 3. Iris Pri 4. Manual 5. White Board | | Exposure mode setting | |
| | Exposure_Comp. | On/ <u>Off</u> | | AE Level | |
| | Exposure_Comp. Level | -6~ <u>0</u> ~4 | | The value can be adjusted only after Exposure_Comp. is activated | |
| | Spot Light | On/ <u>Off</u> | | The value can be adjusted when the mode is set to Full Auto or Shutter Pri. | |
| | Spot Light Position | X(0~8)Y(0~6) | | The value can be adjusted only after Spot Light is activated | |
| | Shutter Pri | | 60/30 mode | 50/25 mode | Shutter priority setting |
| | | | 1/10000 | 1/10000 | |
| | | | 1/5000 | 1/5000 | |
| | | | 1/3000 | 1/3000 | |
| | | | 1/2500 | 1/2500 | |
| 1/2000 | | | 1/1750 | | |
| 1/1500 | | | 1/1250 | | |
| 1/1000 | | | 1/1000 | | |
| 1/725 | | | 1/600 | | |
| 1/500 | | | 1/425 | | |
| 1/350 | 1/300 | | | | |

| | | | | |
|--|-----------------|--|--------------------|-----------------------|
| | | 1/250 | 1/215 | |
| | | 1/180 | 1/150 | |
| | | 1/120 | 1/120 | |
| | | 1/100 | 1/100 | |
| | | 1/90 | 1/75 | |
| | | <u>1/60</u> | <u>1/50</u> | |
| | | 1/30 | 1/25 | |
| | | 1/15 | 1/12 | |
| | | 1/8 | 1/6 | |
| | | 1/4 | 1/3 | |
| | | 1/2 | 1/2 | |
| | | 1/1 | 1/1 | |
| | Iris Pri | <ol style="list-style-type: none"> 1. <u>F1.6</u> 2. F2.2 3. F3.2 4. F4.5 5. F6.3 6. F9 7. F13 8. F18 | | IRIS priority setting |

| | | | | | | | | | | | | | | | | | | | | | | | | | | | | | | | | | | | | |
|---------------|---------------------|---|--|-----------------------|---------------|---------|---------|--------|--------|--------|--------|--------|--------|--------|--------|--------|--------|--------|--------|-------|-------|-------|-------|-------|-------|-------|-------|-------|-------|-------|-------|-------|-------|------|------|--------------------------|
| | Manual Gain | 9. <u>0dB</u> 10. 2 dB 11. 4 dB 12. 6 dB 13. 8 dB 14. 10 dB 15. 12 dB 16. 14 dB 17. 16 dB 18. 18 dB 19. 20 dB 20. 22dB 21. 24dB 22. 26 dB 23. 28 dB 24. 30 dB | | Manually set the gain | | | | | | | | | | | | | | | | | | | | | | | | | | | | | | | | |
| | Manual Speed | <table border="1"> <tr> <td data-bbox="632 952 815 1059">60/30 mode</td> <td data-bbox="815 952 995 1059">50/25 mode</td> </tr> <tr> <td data-bbox="632 1059 815 1126">1/10000</td> <td data-bbox="815 1059 995 1126">1/10000</td> </tr> <tr> <td data-bbox="632 1126 815 1193">1/5000</td> <td data-bbox="815 1126 995 1193">1/5000</td> </tr> <tr> <td data-bbox="632 1193 815 1261">1/3000</td> <td data-bbox="815 1193 995 1261">1/3000</td> </tr> <tr> <td data-bbox="632 1261 815 1328">1/2500</td> <td data-bbox="815 1261 995 1328">1/2500</td> </tr> <tr> <td data-bbox="632 1328 815 1395">1/2000</td> <td data-bbox="815 1328 995 1395">1/1750</td> </tr> <tr> <td data-bbox="632 1395 815 1462">1/1500</td> <td data-bbox="815 1395 995 1462">1/1250</td> </tr> <tr> <td data-bbox="632 1462 815 1529">1/1000</td> <td data-bbox="815 1462 995 1529">1/1000</td> </tr> <tr> <td data-bbox="632 1529 815 1597">1/725</td> <td data-bbox="815 1529 995 1597">1/600</td> </tr> <tr> <td data-bbox="632 1597 815 1664">1/500</td> <td data-bbox="815 1597 995 1664">1/425</td> </tr> <tr> <td data-bbox="632 1664 815 1731">1/350</td> <td data-bbox="815 1664 995 1731">1/300</td> </tr> <tr> <td data-bbox="632 1731 815 1798">1/250</td> <td data-bbox="815 1731 995 1798">1/215</td> </tr> <tr> <td data-bbox="632 1798 815 1865">1/180</td> <td data-bbox="815 1798 995 1865">1/150</td> </tr> <tr> <td data-bbox="632 1865 815 1933">1/120</td> <td data-bbox="815 1865 995 1933">1/120</td> </tr> <tr> <td data-bbox="632 1933 815 2000">1/100</td> <td data-bbox="815 1933 995 2000">1/100</td> </tr> <tr> <td data-bbox="632 2000 815 2040">1/90</td> <td data-bbox="815 2000 995 2040">1/75</td> </tr> </table> | | 60/30 mode | 50/25 mode | 1/10000 | 1/10000 | 1/5000 | 1/5000 | 1/3000 | 1/3000 | 1/2500 | 1/2500 | 1/2000 | 1/1750 | 1/1500 | 1/1250 | 1/1000 | 1/1000 | 1/725 | 1/600 | 1/500 | 1/425 | 1/350 | 1/300 | 1/250 | 1/215 | 1/180 | 1/150 | 1/120 | 1/120 | 1/100 | 1/100 | 1/90 | 1/75 | Manually set the shutter |
| 60/30 mode | 50/25 mode | | | | | | | | | | | | | | | | | | | | | | | | | | | | | | | | | | | |
| 1/10000 | 1/10000 | | | | | | | | | | | | | | | | | | | | | | | | | | | | | | | | | | | |
| 1/5000 | 1/5000 | | | | | | | | | | | | | | | | | | | | | | | | | | | | | | | | | | | |
| 1/3000 | 1/3000 | | | | | | | | | | | | | | | | | | | | | | | | | | | | | | | | | | | |
| 1/2500 | 1/2500 | | | | | | | | | | | | | | | | | | | | | | | | | | | | | | | | | | | |
| 1/2000 | 1/1750 | | | | | | | | | | | | | | | | | | | | | | | | | | | | | | | | | | | |
| 1/1500 | 1/1250 | | | | | | | | | | | | | | | | | | | | | | | | | | | | | | | | | | | |
| 1/1000 | 1/1000 | | | | | | | | | | | | | | | | | | | | | | | | | | | | | | | | | | | |
| 1/725 | 1/600 | | | | | | | | | | | | | | | | | | | | | | | | | | | | | | | | | | | |
| 1/500 | 1/425 | | | | | | | | | | | | | | | | | | | | | | | | | | | | | | | | | | | |
| 1/350 | 1/300 | | | | | | | | | | | | | | | | | | | | | | | | | | | | | | | | | | | |
| 1/250 | 1/215 | | | | | | | | | | | | | | | | | | | | | | | | | | | | | | | | | | | |
| 1/180 | 1/150 | | | | | | | | | | | | | | | | | | | | | | | | | | | | | | | | | | | |
| 1/120 | 1/120 | | | | | | | | | | | | | | | | | | | | | | | | | | | | | | | | | | | |
| 1/100 | 1/100 | | | | | | | | | | | | | | | | | | | | | | | | | | | | | | | | | | | |
| 1/90 | 1/75 | | | | | | | | | | | | | | | | | | | | | | | | | | | | | | | | | | | |

| | | | | |
|--|--------------------|---|---------------------------------|--|
| | | <u>1/60</u> | <u>1/50</u> | |
| | | 1/30 | 1/25 | |
| | | 1/15 | 1/12 | |
| | | 1/8 | 1/6 | |
| | | 1/4 | 1/3 | |
| | | 1/2 | 1/2 | |
| | | 1/1 | 1/1 | |
| | Manual Iris | <ol style="list-style-type: none"> 1. <u>F1.6</u> 2. F2.2 3. F3.2 4. F4.5 5. F6.3 6. F9 7. F13 8. F18 | Manually set the IRIS | |
| | Gain Limit | <ol style="list-style-type: none"> 1. 8 dB 2. 10 dB 3. 12 dB 4. 14 dB 5. 16 dB 6. 18 dB 7. 20 dB 8. 22dB 9. 24dB 10. 26 dB 11. 28 dB 12. <u>30dB</u> | The maximum electric gain limit | |
| | WDR | <ol style="list-style-type: none"> 1. <u>Off</u> 2. 1 3. 2 4. 3 5. 4 6. 5 | Set WDR | |

| | | | |
|----------------------|-------------------------|--|---|
| | Anti Flicker | <ol style="list-style-type: none"> 1. 50Hz 2. 60Hz 3. <u>Off</u> | Set the synchronization frequency for the captured images |
| White Balance | Mode | <ol style="list-style-type: none"> 1. <u>Auto</u> 2. Indoor 3. Outdoor 4. One Push WB 5. ATW 6. Sodium lamp 7. Manual 8. 3000K 9. 4300K 10. 5000K 11. 6500K 12. 8000K 13. WidwAuto | Select the color temperature mode <ol style="list-style-type: none"> 1. 4000k ~ 7000k 2. 3200k 3. 5800k 4. 1700k ~ 10000k 5. 1700k ~ 10000k 6. 2800k 7. Custom 8. 3000K 9. 4300K 10. 5000K 11. 6500K 12. 8000K 13. 3000k ~ 7000k |
| | One Push Trigger | <u>ENTER</u> | One push trigger |
| | Manual Blue | 0~ <u>C</u> ~60 | Adjustable when the white balance mode is set to Manual |
| | Manual Red | 0~ <u>C</u> ~60 | Adjustable when the white balance mode is set to Manual |
| Picture | Picture effect | <ol style="list-style-type: none"> 4. <u>Off</u> 5. Neg 6. B&W | Set the picture effect |
| | Sharpness | 1~ <u>A</u> ~16 | Adjust the sharpness of the image |

| | | | |
|--|------------------------|---|---|
| | 2D NR | <ol style="list-style-type: none"> 1. <u>Auto</u> 2. Off 3. 1 4. 2 5. 3 6. 4 7. 5 | Set 2D noise reduction |
| | 3D NR | <ol style="list-style-type: none"> 1. Off 2. <u>Low</u> 3. Typ 4. Max 5. Auto | Set 3D dynamic noise reduction |
| | Image Mode | <ol style="list-style-type: none"> 1. Mode1 2. Mode2 3. Mode3 4. Mode4 5. <u>Mode5</u> 6. Mode6 7. Custom | The user may customize his/her desired image mode |
| | Image Mode Load | <ol style="list-style-type: none"> 1. <u>Mode1</u> 2. Mode2 3. Mode3 4. Mode4 5. Mode5 6. Mode6 | Adjustable when Image Mode is set to Custom . The user may load an Image Mode and apply it to Custom. |
| | Saturation | 0~ <u>A</u> ~25 | Adjustable when Image Mode is set to Custom . |
| | Hue | 0~ <u>A</u> ~14 | Adjustable when Image Mode is set to Custom . |
| | Gamma | 0~ <u>A</u> ~3 | Adjustable when Image Mode is set to Custom . |
| | Skin Tone | 1~ <u>A</u> ~5 | Set skin tone, Adjustable when Image Mode is set to Custom . |
| | Brightness | 0~ <u>A</u> ~14 | Adjustable when Image Mode is set to Custom . |

| | | | |
|----------------------|------------------------|---|--|
| | Contrast | 0~ <u>A</u> ~14 | Adjust the contrast of the screen, Adjustable when Image Mode is set to Custom . |
| | Black Level | 1. <u>Off</u> 2. Type1 3. Type2 4. Type3 | Adjust the shadow detail and transparency of the screen, Adjustable when Image Mode is set to Custom . |
| Pan Tilt Zoom | Pan/Tilt Limit | ON/ <u>Off</u> | Turn on/off the angle limit setting |
| | Pan Right Limit | 0~ <u>170</u> | Limit the right angle |
| | Pan Left Limit | <u>-170</u> ~0 | Limit the left angle |
| | Tilt UP Limit | 0~ <u>90</u> | Limit the upward angle |
| | Tilt Down Limit | <u>-30</u> ~0 | Limit the downward angle |
| | D-Zoom Limit | <u>x1</u> ~x12 | Limit the D-zoom multiple |
| | Preset Speed | 1. <u>150 deg/sec</u> 2. 250 deg/sec 3. 350 deg/sec | Set the rotation speed of the cradle head when Preset is executed |
| D-effect | Mirror | 1. <u>Off</u> 2. Mirror 3. Flip 4. Mirror + Flip | Set the mode at which the image is turned |
| Auto Focus | AF Sensitivity | 1. Low 2. <u>Middle</u> 3. High | Select the AF triggering speed. The higher the speed is, the faster AF is triggered. |
| | AF speed | Fast/ <u>Normal</u> | Focus speed upon triggering AF |
| | AF Frame | 1. <u>Auto</u> 2. Full Frame 3. Center | AF frame setting. When central area was set as AF frame, focusing will be on the center of the screen. When full area was set as AF frame, focusing will be calculated based on the full screen. |
| System | C-Video | NTSC LB | Image mode |

| | | | |
|---------------|-----------------------|--|--|
| | | NTSC CP | |
| | | <u>NTSC SQ</u> | |
| | | PAL LB | |
| | | PAL CP | |
| | | PAL SQ | |
| | Video Type | SDI | Select output video type |
| | | <u>YPbPr/DVI</u> | |
| | Prompt | ON/ <u>Off</u> | Turn on/off the prompt information on the display |
| | IR Receive | <u>ON</u> /Off | Turn on/off the infrared reception |
| | Language | <u>English</u> /Chinese | Language |
| | Control Device | <u>Encoder</u> / Controller | Set control device |
| | Protocol | <u>Protocol V</u> / Protocol PD | Protocol V : VISCA Protocol PD : PELCO D |
| | PD Address | <u>1</u> ~255 | The Protocol set to PD allows the camera ID address to be assigned |
| | Factory Reset | ON/ <u>Off</u> | Reset all configurations to factory default settings. |
| Status | | | Display the current setting status |

Chapter 6 Descriptions of Major Functions

6.1 I would like to switch to VC-G50

1. Press [**Camera 1 ~ 3**] on the **remote control** to select VC-G50.
 - **Camera 1 ~ 3 is selected with IR SELECT.**

6.2 I would like to save the current lens position data

1. Hold [**Preset + ID**] on the **remote control** to save the current position data.
 - **ID shall be a digit [0 ~ 9].**
 - **Use VISCA Command to save the position data to [0~127]**

6.3 I would like to clear the saved position data

1. Hold [**Reset + ID**] on the **remote control** to clear the given position data.
 - **ID shall be a digit [0 ~ 9].**
 - **Use VISCA Command to clear the position data of [0~127]**

6.4 I would like to turn on the back light compensation function

1. Press [**Back Light**] on the **remote control** to turn on or turn off the back light compensation

6.5 I would like to adjust the shooting angle of the lens

1. Press [**Tilt ▲**] or [**Tilt ▼**] on the **remote control** to adjust the angle upward or downward.
2. Press [**Pan ►**] or [**Pan ◀**] on the **remote control** to adjust the angle to right or left.
3. Press [**Pan - Tilt Reset**] on the **remote control** to reset the angle to the center point.

6.6 I would like to zoom in/out images

6.6.1 Adjust image size

1. Press [**Fast +**] on the **remote control** to zoom in images.
2. Press [**Fast -**] on the **remote control** to zoom out images.

6.6.2 Fine-tune image size

1. Press [**Slow +**] on the **remote control** to zoom in images.
2. Press [**Slow -**] on the **remote control** to zoom out images.

6.7 I would like to adjust the focal length

6.7.1 Auto tune

1. Press [**AF**] on the **remote control** to adjust automatically.

6.7.2 Manual focus

1. Press [**MF**] on the **remote control** to turn on the manual focus function.
2. Press **Focus - [+]** or **Focus - [-]** to adjust.

6.8 I would like to adjust the focus speed

6.8.1 Adjust the AF sensitivity

AF triggering speed. The higher the speed is, the faster AF is triggered.

To shoot fast-moving objects, AF can be set to [**High**] or [**Middle**], which is applicable to quick focus.

When the environment is too dark to enable auto focus or fixed objects have to be shot in different brightness, AF can be set to [**Low**].

1. Press [MENU] to activate the setting menu.
2. Press [▶] or [◀] to select [**Auto Focus**].
3. Press [ENTER] to activate.
4. Press [▲] or [▼] to select [**AF Sensitivity**].
5. Press [ENTER] to activate.
6. Press [▶] or [◀] to select [High/Meddle/Low].
7. Press [MENU] to exit.

6.8.2 Adjust the focus speed

The focus speed upon triggering AF

- [**Normal**] (default): Image flickering may not occur
- [**Fast**]: The focus speed is fast, but image flickering is more likely to occur

1. Press [MENU] to activate the setting menu.
2. Press [▶] or [◀] to select [**Auto Focus**].
3. Press [ENTER] to activate.
4. Press [▲] or [▼] to select [AF Speed].
5. Press [ENTER] to activate.
6. Press [▶] or [◀] to select [Normal/Fast].
7. Press [MENU] to exit.

6.9 I would like to set the image mode

1. Press [**Picture**] on the **remote control** to switch [Off/Neg/B&W].

6.10 I would like to freeze images

1. Press [**Freeze**] on the **remote control** to freeze the current image on the display.

6.11 I would like to rotate the image

1. Press [**Mirror**] on the **remote control** to switch [Off/Mirror/Flip/Mirror + Flip].

6.12 I would like to change the camera direction

1. Press [**L/R Direction Set**] on the **remote control** to switch [L/R Direction / Off / Normal].

6.13 I would like to display the current status

1. Press [**Info**] on the **remote control** to display the current status information.

Chapter 7 DIP Switch Setting

<Note> Please turn off the machine before changing DIP switch setting.

7.1 DIP SWITCH

7.1.1 OUTPUT Switch

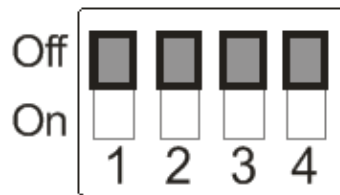

| Output Mode | Setting | Output Mode | Setting |
|------------------|---------|------------------|---------|
| 1920x1080/60p | | 1920x1080/50p | |
| 1920x1080/30p | | 1920x1080/25p | |
| 1920x1080/60i | | 1920x1080/50i | |
| 1280x720/60p | | 1280x720/50p | |
| 1280x720/30p | | 1280x720/25p | |
| 1920x1080/59.94p | | 1920x1080/59.94i | |
| 1920x1080/29.97p | | 1280x720/59.94p | |
| 1280x720/29.97p | | | |

7.1.2 IR SELECT

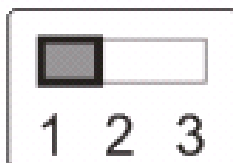

| ID | Setting |
|----|---------|
| 1 | |
| 2 | |
| 3 | |

7.1.3 Camera Address Selector



| Setting | Function Descriptions |
|---------|-----------------------|
| 0~7 | ID 0~7 |
| 8~9 | Reserved |

7.1.4 System Switch



| Setting | Function Descriptions |
|---------|---|
| DIP 1 | RS-232C/RS-422 selector OFF : RS-232C / ON : RS-422 |
| DIP 2 | Infrared signal output switch OFF : Off / ON : On |
| DIP 3 | Communication baud rate selector OFF : 9600 / ON : 38400 |
| DIP 4 | Reserved |

7.2 RS-422 Connection

7.2.1 RS-422 Pin Description

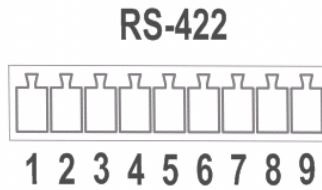

| Pin NO. | Function |
|---------|-----------|
| 1 | RXD OUT - |
| 2 | RXD OUT + |
| 3 | TXD OUT - |
| 4 | TXD OUT + |
| 5 | GND |
| 6 | RXD IN - |
| 7 | RXD IN + |
| 8 | TXD IN - |
| 9 | TXD IN + |

<Note>

For SONY products, please connect IN+ to OUT+

For non-SONY products, it may be necessary to connect IN+ to OUT-

7.2.2 Use RS-422 Connection

1. Hold the two sides of RS-422 connector and pull out in the direction shown by the arrow in the figure below

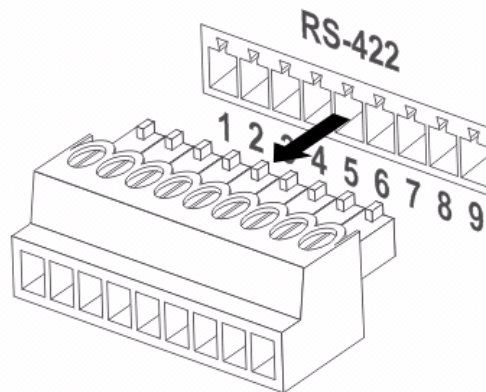

2. Peel off a section of copper wire (AWG Nos.28 to18) and insert it into

the connector hole; then use flat screw driver to fix it

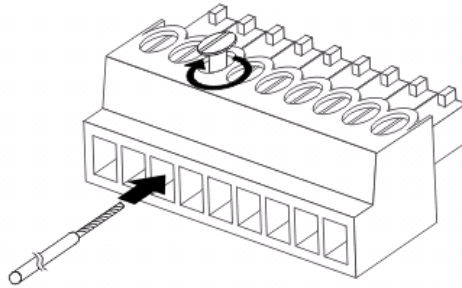

3. Insert the wired RS-422 connector back to the camera. Now the connection is completed

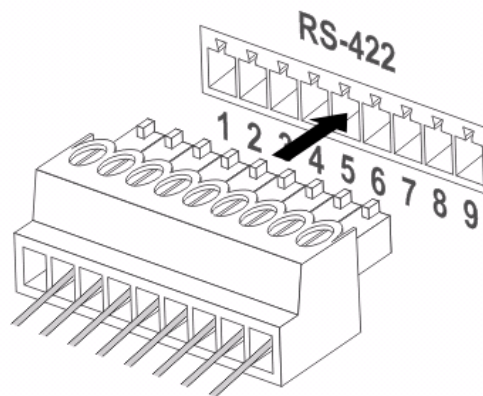

<Note> When RS-422 connection is being used, do not use RS-232C connection.

Chapter 8 Troubleshooting

This chapter describes problems you may encounter while using VC-G50. If you have questions, please refer to related chapters and follow all the suggested solutions. If the problem still occurred, please contact your distributor or the service center.

| No. | Problems | Solutions |
|-----|--|---|
| 1. | Boot without power signal | <ol style="list-style-type: none"> 1. Make sure you have plugged in the power cord. 2. Make sure the Service DIP switch is Off. |
| 2. | No image output from the VC-G50 | <ol style="list-style-type: none"> 1. Check the power. 2. Check if DIP switch is properly set. Refer to Chapter 7 DIP Switch Setting for related settings. 3. Make sure the display supports the output resolution; in general, the resolution is 1080p60/1080i60/720p60. 4. Replace the cables and make sure they are not faulty. |
| 3. | VC-G50 image is severely delayed | Please use 1080p or 720p 60/50 Hz signals rather than 25/30 Hz signals. |
| 4. | Not working after changes to DIP Switch setting | After completing DIP Switch setting, unplug and reconnect the power cord and turn on the machine to change the setting. |
| 5. | VC-G50 cannot be operated by remote control | <ol style="list-style-type: none"> 1. Please confirm if the Camera Select on the remote control can be used together with the IR Select on VC-G50. 2. Please prevent VC-G50 from direct sunshine. 3. Make sure the energy-saving bulb and the IR touch screen are as far as possible in order to avoid interference. 4. When several VC-G50s are connected in the same area, the operation of two remote controls at the same time may result in signal interference. It is recommended to use one remote control only. |
| 6. | The device cannot be controlled with Codec | <ol style="list-style-type: none"> 1. Please consult the distributor to make sure the firmware version is the latest one. The steps to check version is as follows: <ol style="list-style-type: none"> 1.1 Press [MENU] on the remote control 1.2 Select [Status] 1.3 Go to Page 5 of [System] 1.4 Make sure the firmware version is correct |

| | | |
|----|--|---|
| | | <ol style="list-style-type: none"> 2. Make sure the connection is correct (RS-232/422 Input). 3. Make sure System Switch DIP1 and DIP3 are correct. |
| 7. | The device cannot be controlled with RS-232/RS422 | <ol style="list-style-type: none"> 1. Make sure the connection is correct (RS-232/422 Input). 2. Make sure System Switch DIP1 and DIP3 are correct. |