

XE166 Family Easy Kit

Board REV. V3.1

Microcontrollers



Never stop thinking.

Edition 2008-11

**Published by
Infineon Technologies AG
81726 München, Germany**

**© Infineon Technologies AG 2008.
All Rights Reserved.**

Legal Disclaimer

The information given in this document shall in no event be regarded as a guarantee of conditions or characteristics ("Beschaffheitsgarantie"). With respect to any examples or hints given herein, any typical values stated herein and/or any information regarding the application of the device, Infineon Technologies hereby disclaims any and all warranties and liabilities of any kind, including without limitation warranties of non-infringement of intellectual property rights of any third party.

Information

For further information on technology, delivery terms and conditions and prices please contact your nearest Infineon Technologies Office (www.infineon.com).

Warnings

Due to technical requirements components may contain dangerous substances. For information on the types in question please contact your nearest Infineon Technologies Office.

Infineon Technologies Components may only be used in life-support devices or systems with the express written approval of Infineon Technologies, if a failure of such components can reasonably be expected to cause the failure of that life-support device or system, or to affect the safety or effectiveness of that device or system. Life support devices or systems are intended to be implanted in the human body, or to support and/or maintain and sustain and/or protect human life. If they fail, it is reasonable to assume that the health of the user or other persons may be endangered.

XE166 Family Easy Kit

Revision History: 2008-11

V 1.0

Previous Version:

Page	Subjects (major changes since last revision)

We Listen to Your Comments

Any information within this document that you feel is wrong, unclear or missing at all?
Your feedback will help us to continuously improve the quality of this document.

Please send your proposal (including a reference to this document) to:
mcdocu.comments@infineon.com



Table of Contents		Page
1	Introduction - XE166 family	5
2	General Information about XE166 Easy Kit Board	6
2.1	Summary of Features	6
2.2	Block Diagram	7
2.3	Board Overview	8
2.4	DIP Switch S102	10
2.4.1	Basic Startup Configuration for XE166F	10
2.4.2	Basic Startup Configuration for XE166FM	11
2.5	USB Driver installation	12
2.6	Easy Kit Power Supply concept	13
2.6.1	Power Supply via Power Plug	14
3	Information in Detail	15
3.1	Switch S102	16
3.1.1	DIP Switch Setting XE166F	16
3.1.2	DIP Switch Setting XE166FM	17
3.2	Headers, Connectors and Components	18
3.2.1	USB Interface	18
3.2.2	CAN1/2 (X110, X111)	18
3.2.3	LIN Interface (X104)	19
3.2.4	OCDS Interface	19
3.2.5	DAP Interface	20
3.2.6	ADC	21
3.2.7	LEDs	21
3.2.8	Serial Eeprom	21
3.3	Pin Definition and Location	22
3.3.1	XE167F/XE167FM - 144 - Pinout	22
3.3.2	XE164F/XE164FM - 100 - Pinout	24
3.3.3	XE162FM - 64 - Pinout	26
3.4	Zero Ohm Resistors	27
4	Getting Started	29
4.1	Power Supply	30
4.2	OCDS Debugging Interface	31
4.3	USB Interface for UART support	31
5	Schematic	32

1 Introduction - XE166 family

XE166 family - More performance, more Flash, better peripherals

With more than 15 successful years in the microcontroller market place, C166 has set the standard for 16-bit architectures with the highest aggregate volume share of all available 16-bit devices.

With its fast interrupt response and context switching, the C166 family is ideally suited for automotive, industrial, mass storage and wired as well as wireless communications applications.

Compared with the XC166, XE166 delivers more performance, more Flash memory, more RAM, strongly enhanced peripherals and a complete DSP library.

MCU and DSP in a core

Infineon Technologies' Real Time Signal Controller combines the traditional strengths of a Microcontroller Unit (MCU) to control peripherals with the computing power of Digital Signal Processors (DSP). All in one enhanced XE166 core. Together, the Microcontroller's real-time capability and ease of use and the DSP's mathematical performance and data throughput form a powerful single-chip solution ideal for many embedded applications.

For detailed technical information about the different derivatives please refer to the XE166 family web pages on the Infineon Internet.

<http://www.infineon.com/XE166>

This document covers several product series.

- **XE167F Series**
- **XE164F Series**
- **XE167FM Series**
- **XE164FM Series**
- **XE162FM Series**

2 General Information about XE166 Easy Kit Board

2.1 Summary of Features

- Infineon's XE166 Controller in TQFP144/100/64 Pin Package
- High Speed CAN Transceivers, LIN Transceiver, USB to UART/JTAG bridge
- 8 Low Power Status LEDs
- Easy access to all pins
- 5-DIP switches for configuration
- On board USB to JTAG / UART interface
- Powered via USB

Connectors

The XE166 Board offers a wide variety of connectors:

- USB connector for ASC/JTAG Interface
- 4 pin header for LIN Transceiver
- 16-pin header for JTAG interface (OCDS)
- 10pin (2x5) header for CAN High Speed Transceiver (CAN1/CAN2)
- 10pin header for DAP interface

Components

- Low-Drop Voltage Regulator TLE 4274
- Step Down Voltage Regulator TLE 6365G (optional)
- Four status LED's for Power / RESET / JTAG
- 2 x CAN-Transceiver TLE 6251
- LIN Transceiver TLE 7259
- FT2232 Dual USB to UART/JTAG interface
- SPI EEPROM 128 Kbit AT25128N
- 8 general purpose LEDs
- Potentiometer for ADC
- Reset switch

Zero Ohm Bridges

- Zero Ohm resistors give the flexibility to configure the systems functionality

2.2 Block Diagram

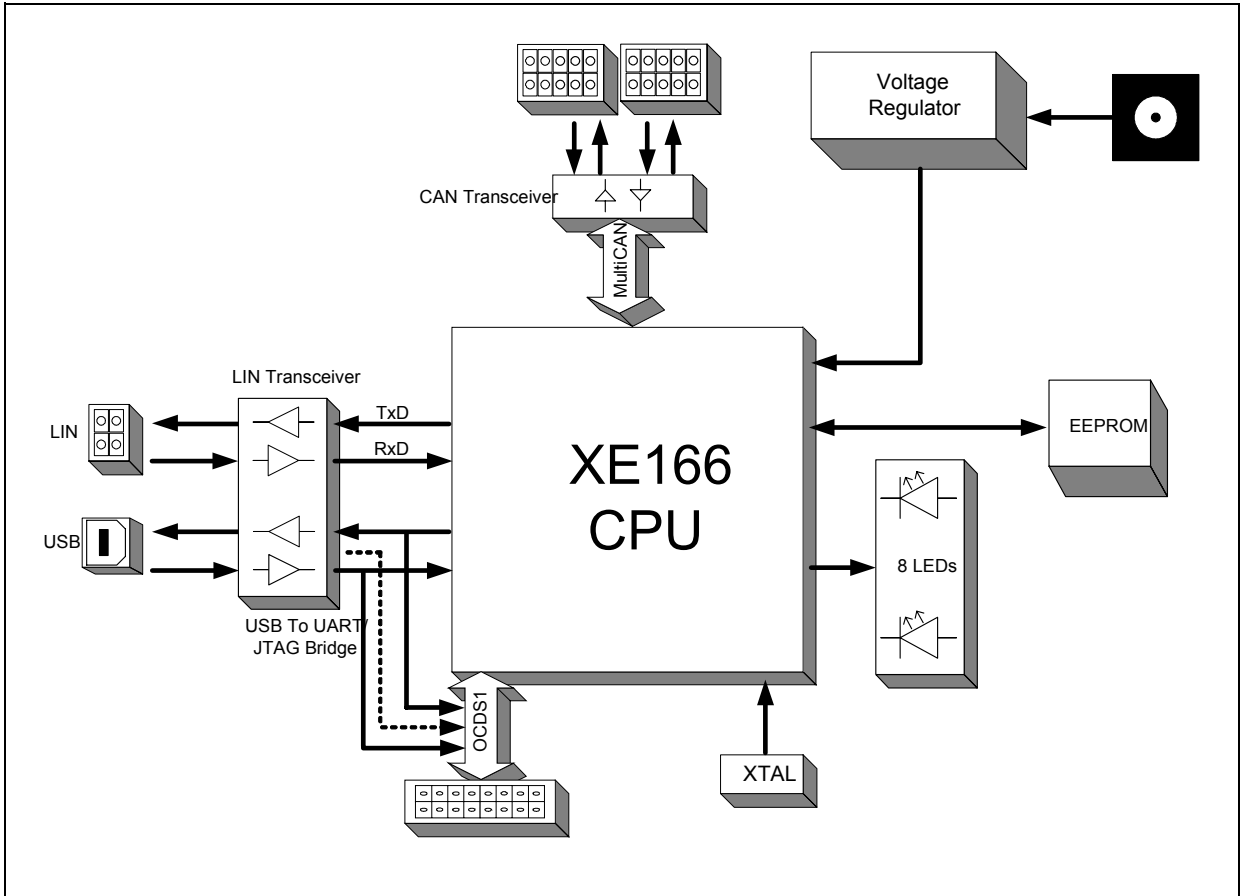

Figure 1 Block diagram of XE166 Easy Kit layout overview

2.3 Board Overview

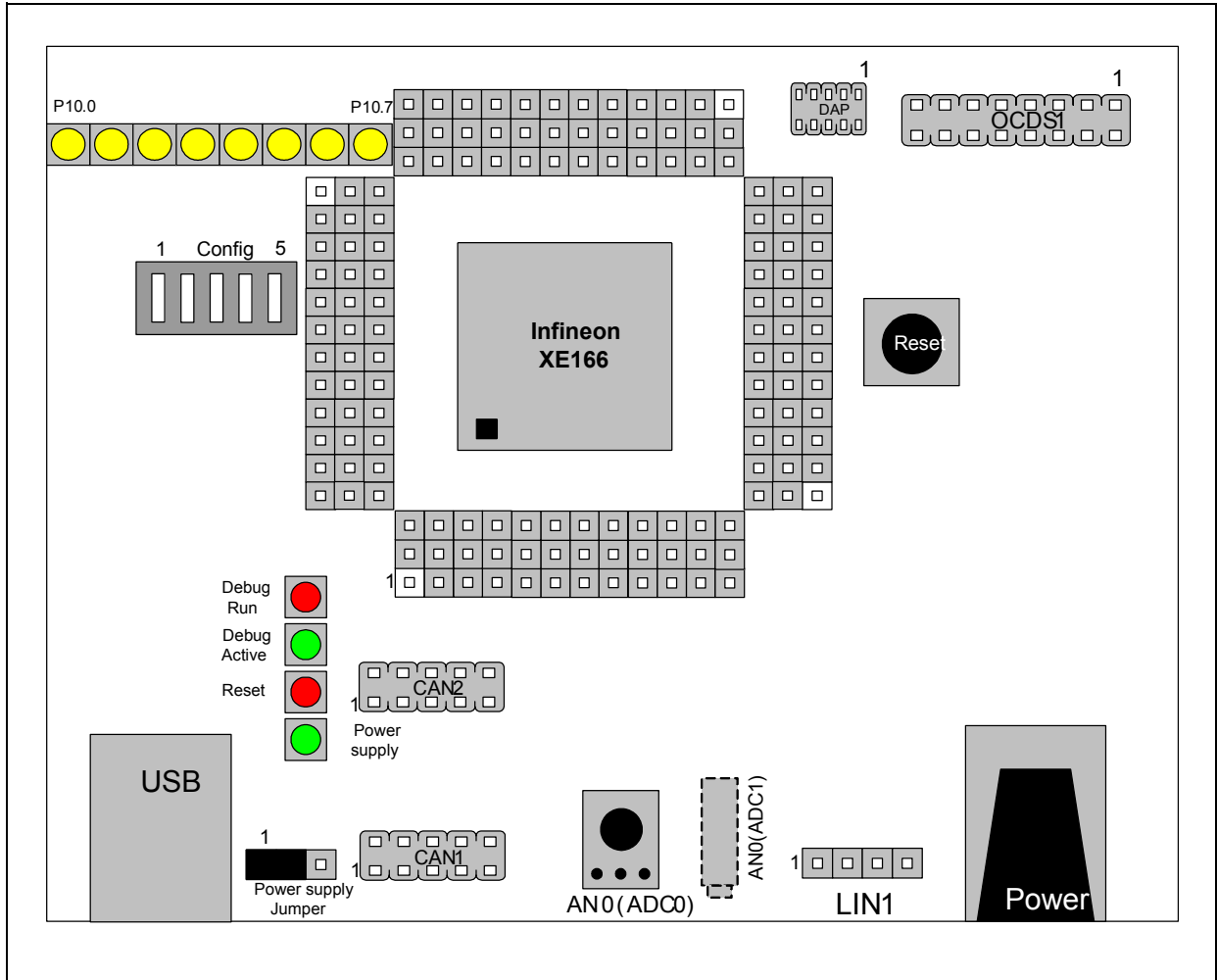

Figure 2 Top View (basic components)

General Information about XE166 Easy Kit Board

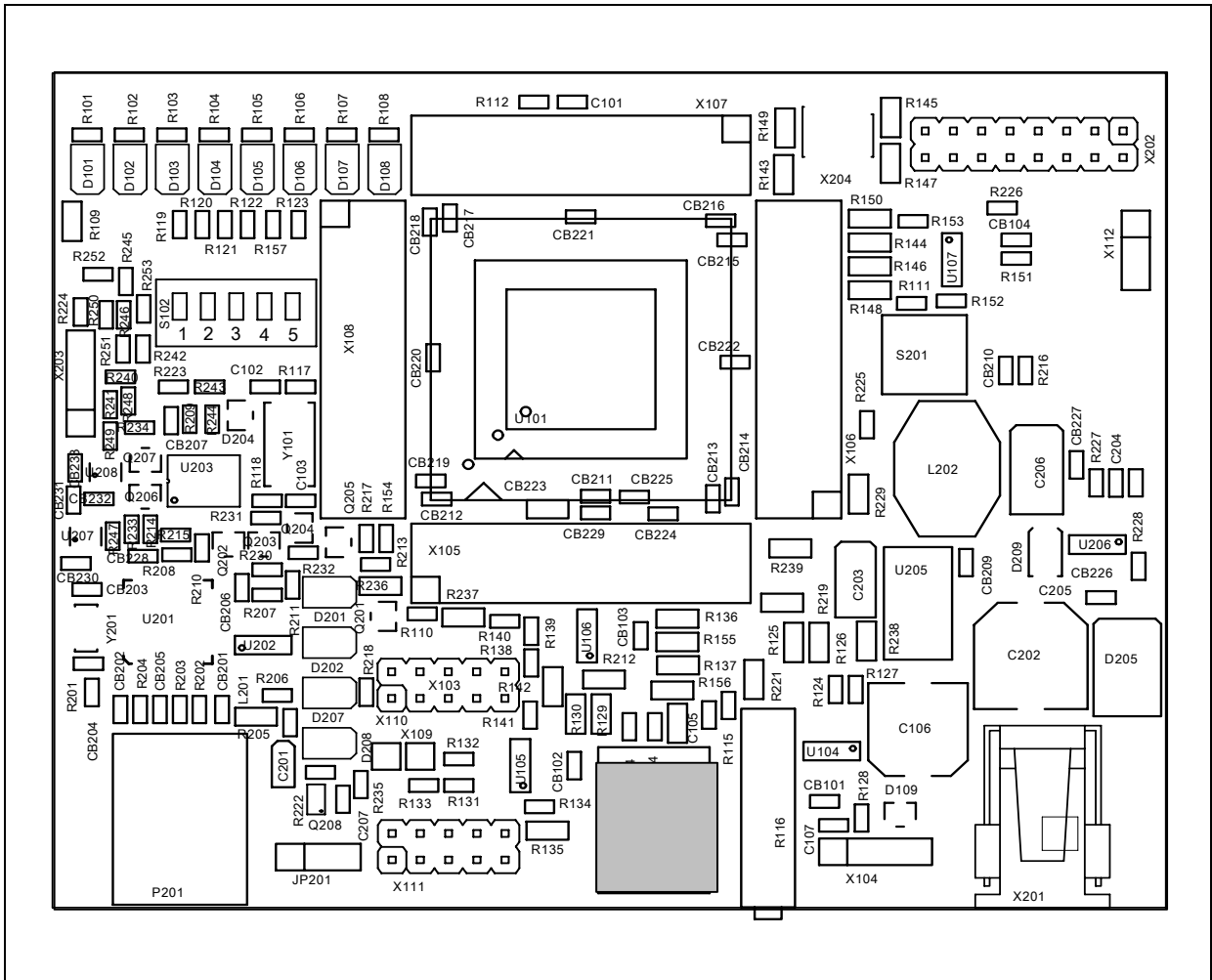

Figure 3 Top view in detail

General Information about XE166 Easy Kit Board

2.4 DIP Switch S102

Although most of the programmable features of the XE166 are selected by software either during the initialization phase or repeatedly during program execution, some features must be selected earlier because they are used for the first access of the program execution.

These configurations are accomplished by latching the logic levels at a number of pins at the end of the internal reset sequence.

DIP switch S102 allows to configure the startup setting of the XE166 during RESET. The default System Startup Configuration is shown in [Table 1](#). By default all DIP Switches are OFF. The XE166 executes a standard start from internal Flash.

Table 1 Default configuration

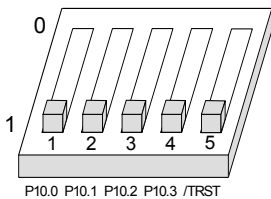
Name in schematic	Default configuration	Description
S102		Startup configuration: Standard start from internal Flash (Default)

2.4.1 Basic Startup Configuration for XE166F

Table 2 Basic Startup Configuration via External Circuitry

Startup Mode	CFG pins P10 [3]	CFG pins P10 [2]	CFG pins P10 [1]	CFG pins P10 [0]
	P10 [3 : 0] ¹⁾			
Internal Start from Flash	x	x	1	1
Standard UART Bootloader	x	1	1	0
Enhanced UART Bootloader	x	0	1	0
SSC Bootloader	1	0	0	1
CAN Bootloader	x	1	0	1

¹⁾ x means that the level on the corresponding pin is irrelevant.

For more detailed information about the DIP switch setting please refer to [Chapter 3.1.1](#), [Table 6](#).

2.4.2 Basic Startup Configuration for XE166FM

Table 3 Basic Startup Configuration with debug support

Startup Mode	Debug Interface	CFG pins P10 [3:0] ¹⁾ $\overline{\text{TRST}}=1$			
Internal Start from Flash	JTAG pos.B	x	0	1	1
	DAP pos.1	x	1	0	0
	from Flash ²⁾	x	1	1	1
	DAP pos.0	0	0	0	1
	DAP pos.2	0	1	0	1

¹⁾ x means that the level on the corresponding pin is irrelevant.

²⁾ A defined location in Flash (C0'01F0_H) must contain a value (2 Bytes) for DBGPRR register and the next word-location (C0'01F2_H) must contain the inverse value.

If the inverse-condition does not match - the value is considered as invalid and JTAG pins at position A are configured by default.

Table 4 Basic Startup Configuration via External Circuitry

Startup Mode	Configuration pins ¹⁾				
	$\overline{\text{TRST}}$	P10 [3 : 0]			
Internal Start from Flash	0	x	x	x	x
UART Bootloader 2.x ²⁾	1	x	0	1	0
UART Bootloader 7.x ³⁾	1	x	1	1	0
SSC Bootloader	1	1	0	0	1
CAN Bootloader	1	1	1	0	1

¹⁾ x means that the level on the corresponding pin is irrelevant.

²⁾ 2.x means: TxD (transmit data) at P2.3 pin, RxD (receive data) at P2.4 pin.

³⁾ 7.x means: TxD (transmit data) at P7.3 pin, RxD (receive data) at P7.4 pin.

For more detailed information about the DIP switch setting please refer to [Chapter 3.1.2, Table 7](#).

2.5 USB Driver installation

All USB-Transaction are realized by the USB-Software running on a Host-Computer. The USB-Device driver is communicating with the Equipment connected to the Computer.

The driver for Easy Kit USB interface will be delivered with a Software called DAS (Device Access Server). The goal of the DAS architecture is to provide one single interface for all types of tools, which fulfills all performance and reliability needs. Additionally a driver for a virtual COM port will be installed.

Find out more about DAS on the Infineon Web page:

<http://www.infineon.com/DAS>

This DAS Software can be found on the Easy Kit CD under Tools. A DAS Software Version 2.6.1 or higher need to be used for the Easy Kit.

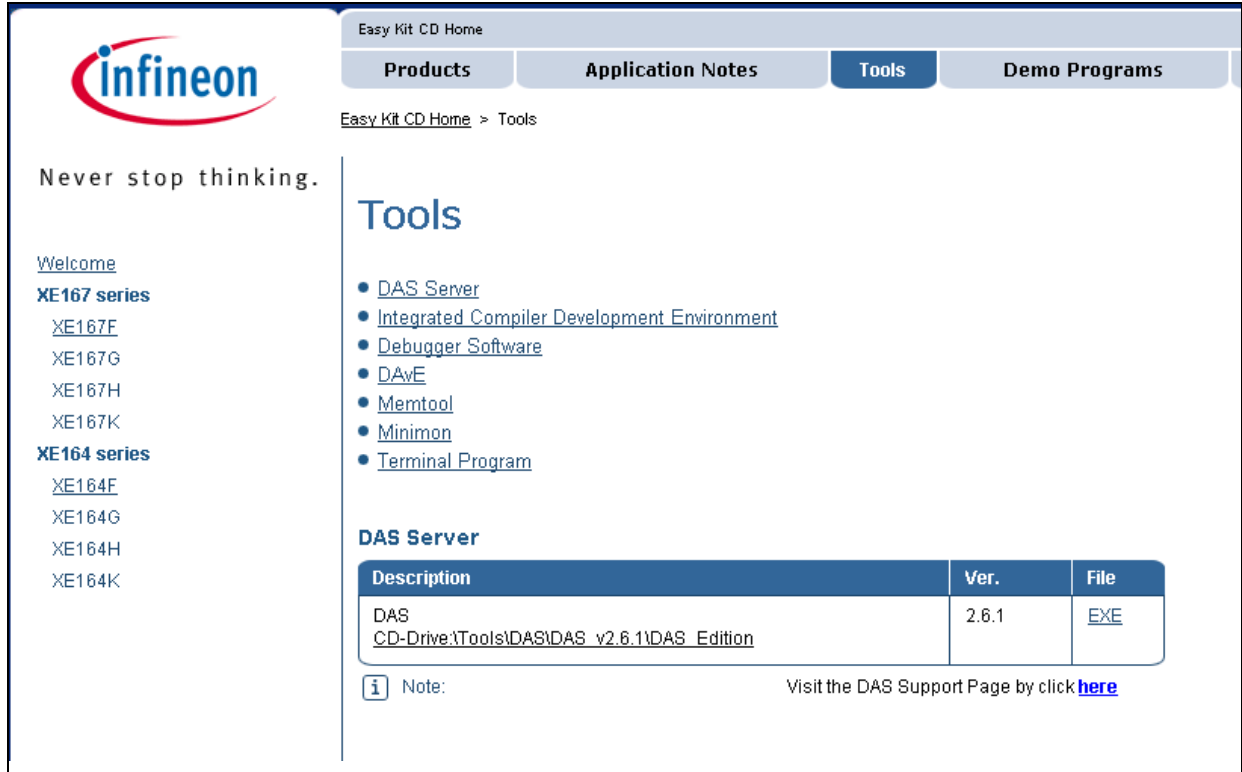

The screenshot shows the Infineon Easy Kit CD Home website. The navigation bar includes 'Products', 'Application Notes', 'Tools', and 'Demo Programs'. The 'Tools' section is active, displaying a list of tools: DAS Server, Integrated Compiler Development Environment, Debugger Software, DAvE, Memtool, Minimon, and Terminal Program. Below this, the 'DAS Server' section features a table with the following data:

Description	Ver.	File
DAS CD-Drive:\Tools\DAS\DAS v2.6.1\DAS_Edition	2.6.1	EXE

A note at the bottom of the page states: 'Note: Visit the DAS Support Page by click [here](#)'.

General Information about XE166 Easy Kit Board

2.6 Easy Kit Power Supply concept

The Easy Kit USB Power Supply concept enables the user to work with the Kit without an external Power Supply. If the USB power supply is not sufficient an additional regulated DC power supply can be used.

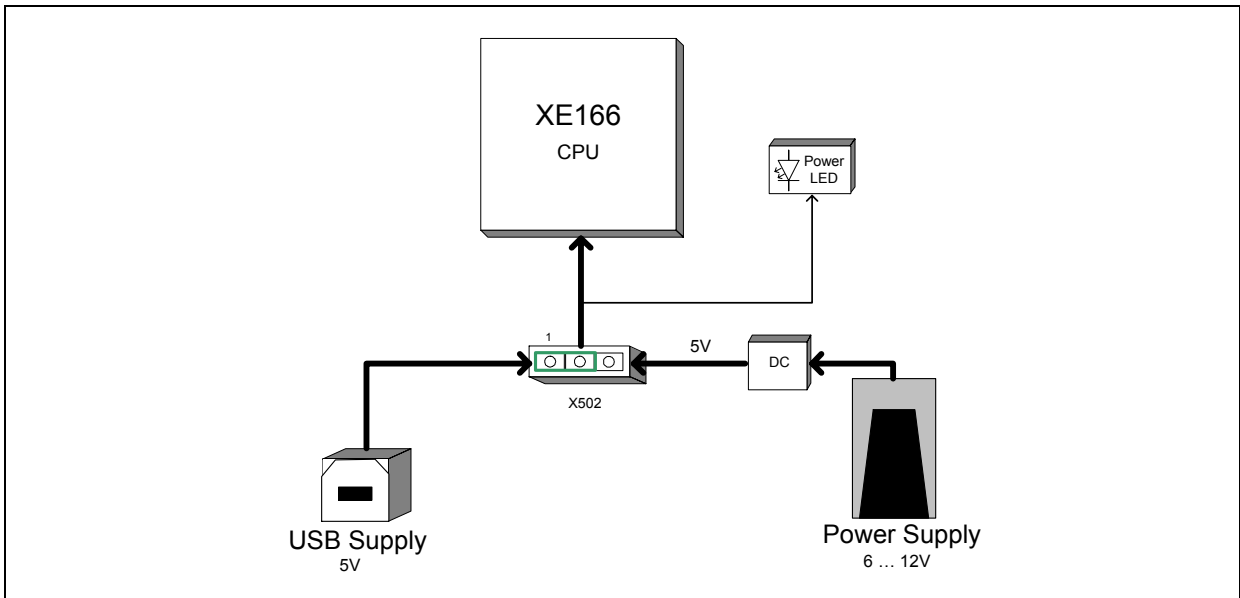
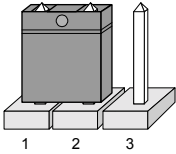
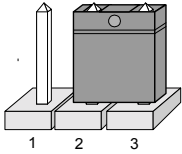

Figure 4 Easy Kit Power Supply concept

By means of the Power Supply Jumper X502, USB, or the external power Supply can be selected to run the Easy Kit. The Setup for the Jumper X502 is shown in [Table 5](#) below.

Table 5 Power Supply Jumper configuration

Name in schematic	Configuration	Description
X502		Power Supply via USB Interface (Default)
X502		Power Supply via Power Plug

General Information about XE166 Easy Kit Board

The USB specification provides a 5 V supply on a single wire from which connected USB devices may draw power. The specification provides for no more than 5.25 V and no less than 4.35 V between the +ve and -ve bus power lines.

Initially, a device is only allowed to draw 100 mA. It may request more current from the upstream device in units of 100 mA up to a maximum of 500 mA. In practice, most ports will deliver the full 500 mA or more before shutting down power, even if the device hasn't requested it or even identified itself. If a (compliant) device requires more power than is available, then it cannot operate until the user changes the network (either by rearranging USB connections or by adding external power) to supply the required power.

Note: If the USB power supply is not sufficient, an external power supply is needed and the Jumper X502 setting need to be changed.

Note: In case the USB Host PC goes into Suspend Mode, an external Power Supply should be used.

2.6.1 Power Supply via Power Plug

The XE166 Board can be supplied either with USB cable or with an external power supply. For external power supply a regulated DC power supply with **max. 12Volt/400mA** can be connected to the power connector. The maximum power dissipation of the used voltage regulator has to be taken into account.

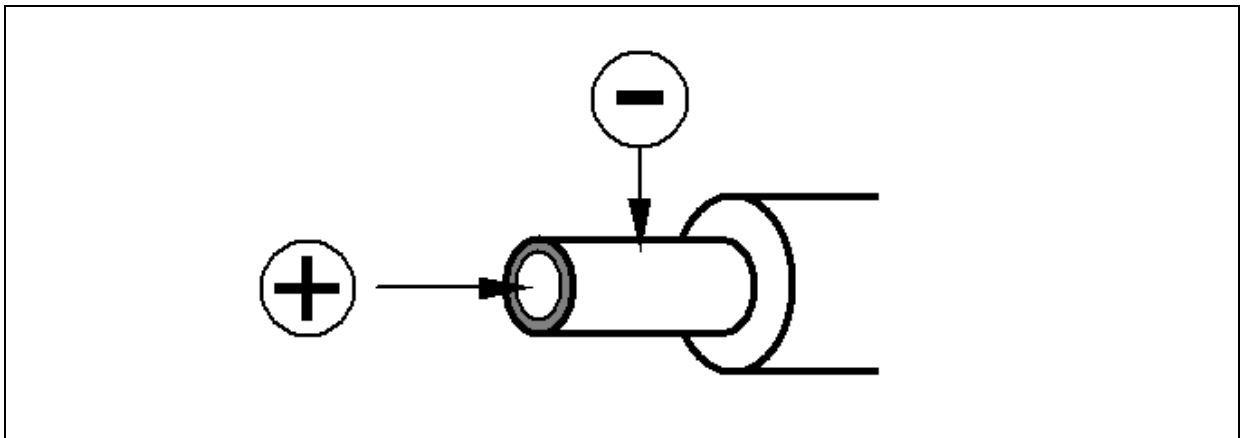

Figure 5 Power Supply

3 Information in Detail

The XE166 family supports variety of start-up modes, allowing the user to make selections in three aspects:

- Main functionality - where from the user code will be started (on-chip Flash, PSRAM, external memory);
- Optionally - a way for initial code-downloading into PSRAM before to start it:
 - From an external host via a communication interface - UART, CAN, SSC;
 - From Stand-by RAM (SBRAM) - after exiting a power-saving mode;
- Debug-related - either debugging will be possible, and if Yes - which debug-interface to use (JTAG, DAP, selectable pin-assignments).

The Easy Kit Board Manual covers only a limit numbers of start-up modes. For all possible start-up modes please refer to the corresponding user manual.

3.1 Switch S102

3.1.1 DIP Switch Setting XE166F

Table 6 DIP Switch Settings for S102

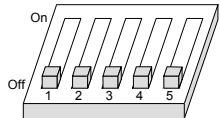
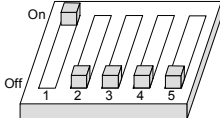
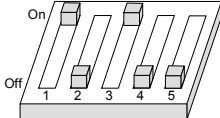
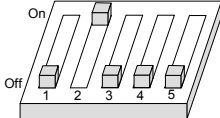
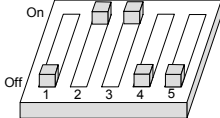
Name in schematic	Default configuration	Description
S102		Startup configuration: Standard start from internal Flash OFF-OFF-xx-xx-xx
S102		Startup configuration: Bootstrap loader ASC ON-OFF-OFF-xx-xx
S102		Startup configuration: Enhanced bootstrap loader ASC ON-OFF-ON-xx-xx
S102		Startup configuration Bootstrap loader CAN OFF-ON-OFF-xx-xx
S102		Startup configuration Bootstrap loader SSC OFF-ON-ON-OFF-xx
S102		Startup configuration All other positions are reserved

3.1.2 DIP Switch Setting XE166FM

Table 7 DIP Switch Settings for S102

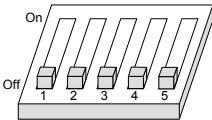
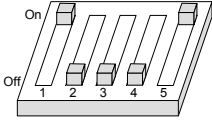
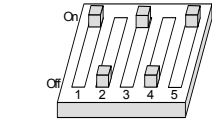
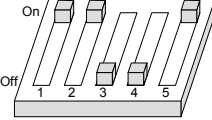
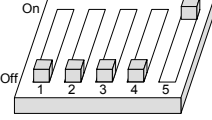
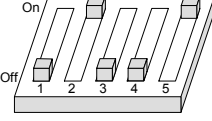
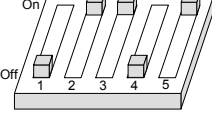
Name in schematic	Default configuration	Description
S102		Startup configuration: Standard start from internal Flash xx-xx-xx-xx-OFF
S102		Startup configuration: Bootstrap loader ASC For XE167FM and XE164FM ON-OFF-OFF-xx-ON
S102		Startup configuration: Bootstrap loader ASC for XE162FM ON-OFF-ON-xx-ON
S102		Startup configuration: DAP Debug Mode (Pos.1) ON-ON-OFF-xx-ON
S102		Startup configuration: JTAG Debug Mode (Default) OFF-OFF-OFF-xx-ON
S102		Startup configuration: Bootstrap loader CAN OFF-ON-OFF-OFF-ON
S102		Startup configuration: Bootstrap loader SSC OFF-ON-ON-OFF-ON
S102		Startup configuration All other positions are reserved

3.2 Headers, Connectors and Components

3.2.1 USB Interface

The USB connector is used for connection to a PC. Via the USB it is possible to power the board, using the USIC0 Channel 0 as serial connection via USB and Debugging via DAS. For the pinout of USB socket see Figure 6.

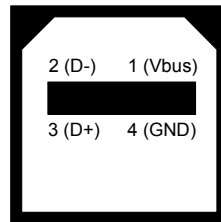

Figure 6 On-board header (P201)

3.2.2 CAN1/2 (X110, X111)

On the board are two CAN transceiver connected to the MultiCAN on XE166 node 0 and 1. The transceivers are connected to two IDC10 plug. For the pinout of IDC10 plug see Figure 7. You can use a IDC female connector with crimpconnector, flat cable and SUB-D 9 plug with crimpconnector to have a 1:1 adapter to SUB-D 9.

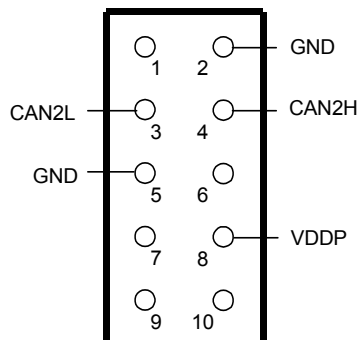

Figure 7 On-board header (X110,X111)

Note: If the Board is equipped with a XE162FM in a 64 Pin package the CAN2 interface is disabled. To enable remove R238 and solder R136. In this case Usic 0 channel 0 is not available on Pin 2.4 .

3.2.3 LIN Interface (X104)

The board has a connector with 4 pins for LIN. For the pinout of the connector see Figure 8. The LIN transceiver is connected to USIC1 Channel 0 module of the CPU.

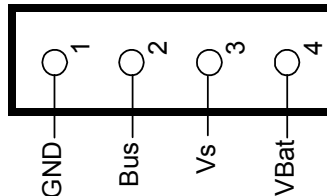

Figure 8 On-board header (X104)

3.2.4 OCDS Interface

The OCDS1 signals are connected to the IDC16 plug (X202). For pinout of the connector see Figure 9. You can connect any debugger to this connector.

The signals /BRKIN and /BRKOUT are not connected per default. If you need this signals in the connector then assemble R225 and R226 with a 0R resistor.

If you connect a debug hardware make sure that the MiniWiggler circuit is not active (ACTIV LED is off) and on the DAP connector (X204) is no hardware connected or the hardware is tristated.

If the ACTIV LED is on, then stop the active DAS Server JTAG over USB Chip and/or remove the USB connection to the PC.

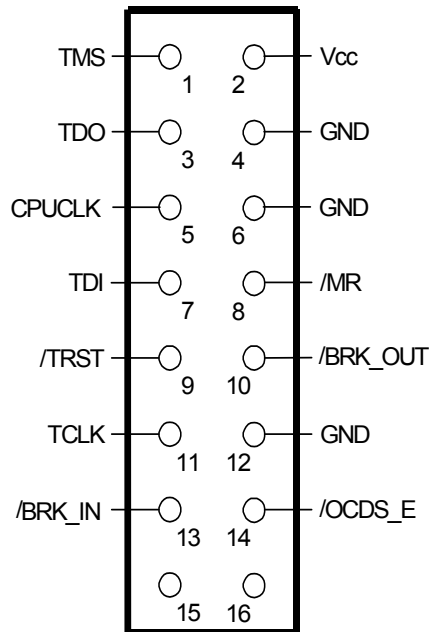

Figure 9 On-board header X202

3.2.5 DAP Interface

The board comes with a DAP connector (X204). For pinout of this connector see Figure 10. You can connect a DAP hardware here. If you use this connector make sure that the MiniWiggler is not active (ACTIV LED is off) and a connected OCDS1 hardware is disconnected or tristated.

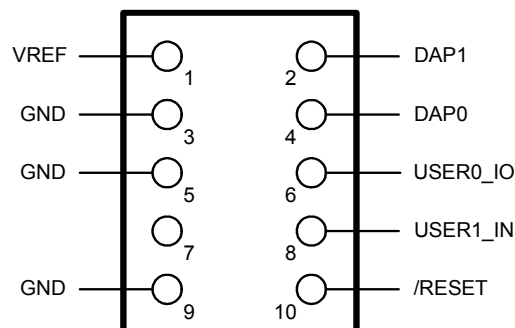

Figure 10 On-board header X204

3.2.6 ADC

On AN0 (ADC0) is a 10K potentiometer (R113) connected. You can apply a voltage between VAGND0 and VAREF0 to the AN0 channel via this potentiometer.

R116 is connected to AN0 (ADC1). The potentiometer is not assembled by default. You can assemble a potentiometer to use this connection. The footprint is prepared for a Burns potentiometer typ 3006.

3.2.7 LEDs

Port 10 pin 0 up to pin 7 are connected to single LED's (D101... D108) and can be controlled by Software. This status LED's are low active.

Table 8 LEDs description

LED number	Description
D201 (red)	Debug Run Mode (switched by DAS Server)
D202 (green)	Debug Active (Mini Wiggler circuit active)
D207 (red)	Power On Reset Active
D208 (green)	Board Voltage 5 Volt
D101 - D108 (yellow)	Status of P10L

3.2.8 Serial Eeprom

By default the USIC0 Channel1 of the XE166 is connected to a serial EEPROM with a size of 128K (16.384 x 8). If the SSC bootstrap loader is needed the four resistors have been reconfigured as described in table 8.

Table 9 Serial Eeprom interface

Default Setting: SSC (USIC0 Channel 1)	SSC bootstrap loader (USIC0 Channel 0)
P10.5 (SCK) with R143	P2.5 (SCK) replace R143 with R144
P10.0 (SI) with R145	P2.4 (SI) replace R145 with R146
P10.7 (SO) with R147	P2.3 (SO) replace R147 with R148
P2.7 (CS) with R149	P2.6 (CS) replace R149 with R150

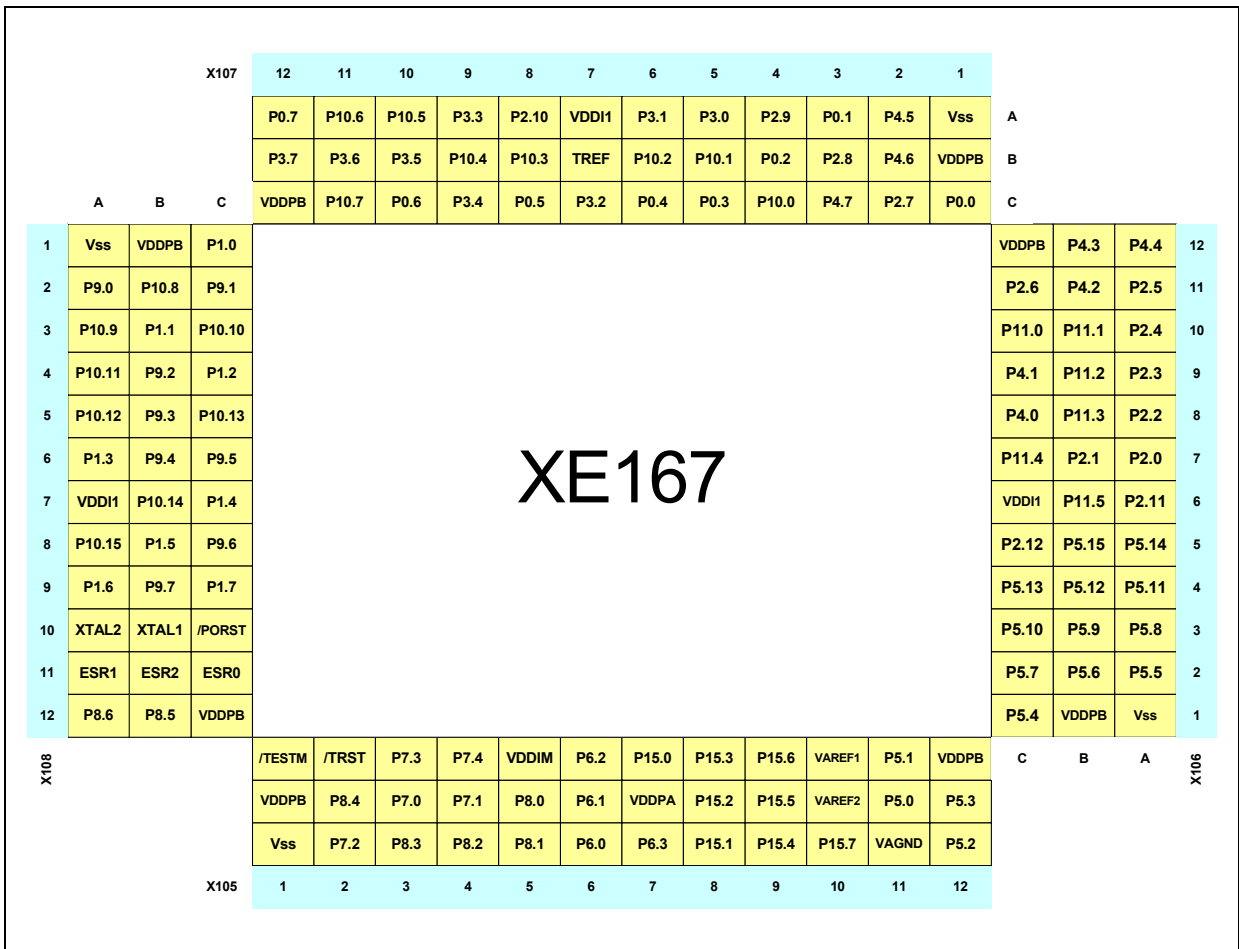

Figure 12 Pin connector of the 144 pin device

3.3.2 XE164F/XE164FM - 100 - Pinout

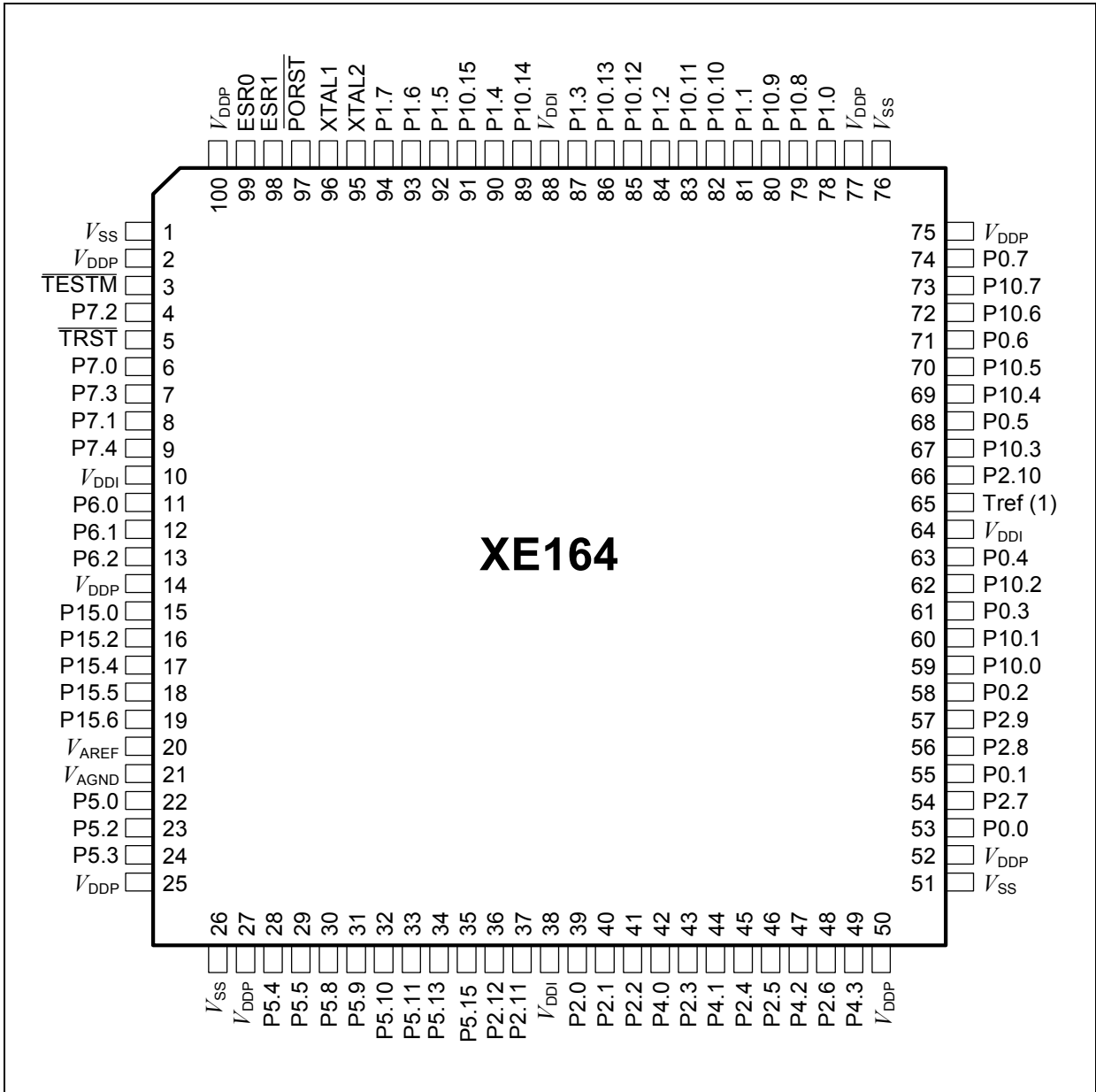

Figure 13 Pinout of the 100 pin device

Note: (1) For the XE166FM Series the Tref pin has been replaced by P2.13.

3.3.3 XE162FM - 64 - Pinout

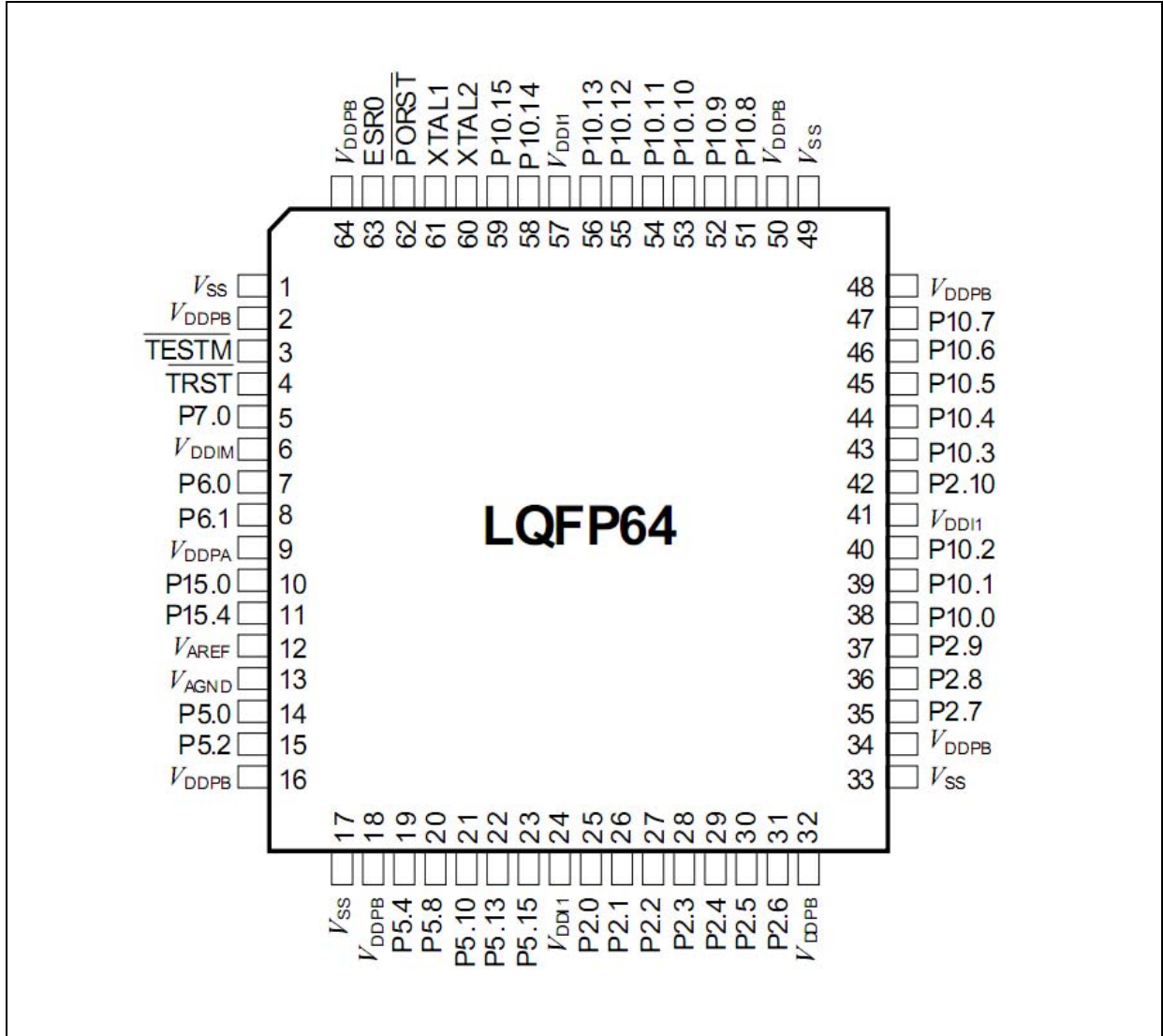

Figure 15 Pinout of the 64 pin device

3.4 Zero Ohm Resistors

For configuration purposes several zero ohm resistors have been implemented. The functionality of these resistors are shown in the table below.

Table 10 Zero Ohm Resistors

Component	Name in schematic	Description
TLE 7259G (LIN Transceiver Board)	R124 R125 / R126	enable / disable connect / disconnect
TLE 6251DS (CAN Transceiver)	R129 / R130 R136 / R137 R155 / R156 R131 R138 R135 R142 R133 / 134 R140 / 141	connect / disconnect (CAN1) connect / disconnect (CAN2) or connect / disconnect (CAN2) enable / disable (CAN1) enable / disable (CAN2) supply Bus voltage internal / external (CAN1) supply Bus voltage internal / external (CAN2) connect Bus / disconnect Bus (CAN1) connect Bus / disconnect Bus (CAN2)
Microcontroller XE166 Analog reference	R220 / R221 R219	change of analog reference source
Voltage supply	R212 / R229	change of voltage supply
JTAG X202	R225 R226	/BRKIN (optional) /BRKOUT (optional)
AT25128N (Serial EEPROM)	R143 / R145 R147 / R149 R144 / R146 R148 / R150	connect to USIC1 Channel1 connect to USIC1 Channel1 connect to SSC bootstrap loader (U0C0) connect to SSC bootstrap loader (U0C0)

Table 10 Zero Ohm Resistors

Component	Name in schematic	Description
Status LED's Oscillator circuit	R109 R117/R118	connect / disconnect LED's to 5 V oscillator gain
FT2232D (USB to UART / JTAG Bridge):		
JTAG-Option:	R224 R223 R242-R246 R247-R253	/BRKOUT (optional) /BRKIN (optional) assembled with 0R open
DAP-Option:	R242-R246 R247-R252 R253	open assembled with 0R assembled with 47K
ASC Bootloader: 144Pin / 100 Pin	R236-R237 R238-R239	assembled with 0R open
Other	R236-R237 R238-R239	open assembled with 0R
U203:	R210	For internal use only
EEPROM 93LC46B:	R207	If ORG functionality is needed

4 Getting Started

For the successful start up of the XE166 Easy Kit, the following items should be done:

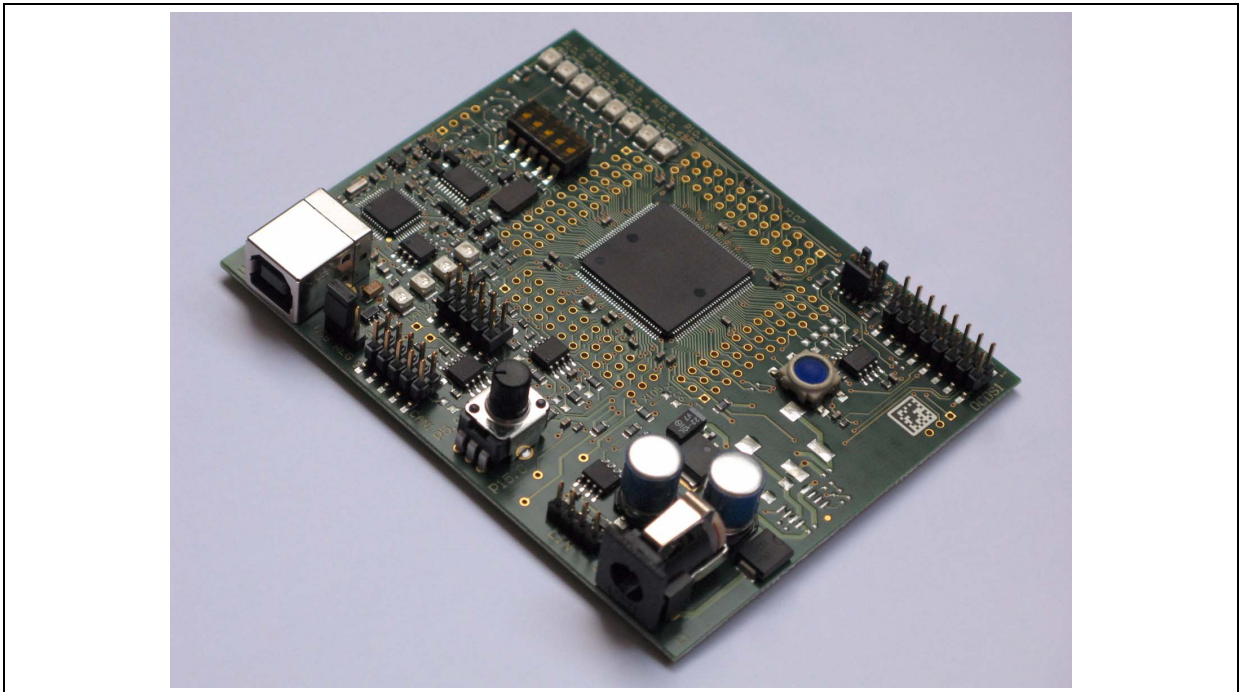

Figure 16 XE166 Easy Kit (144-Pin)

By default a HELLO WORLD program can be executed. The following steps are needed to be successful.

1. Verify that the Jumper JP201 is in position 1-2 (powered via USB).
2. Connect USB cable with starterkit and PC.
3. Install DAS driver from starterkit CD.
4. Verify if the standard start mode is selected as described in chapter 3.1.
5. LED D105 connected with P10.0 should flash, otherwise press the Reset button.
6. Verify which COM port is activated for the FTDI - chip.
7. Execute the monitor program MTTTY from the starterkit CD.
8. Select the corresponding COM port, 19200 Baud, none parity, 8 data Bit, one stop bit, parser off.
9. Start connection (File/connect).
10. Press Reset button on the starterkit, Hello World program is running .

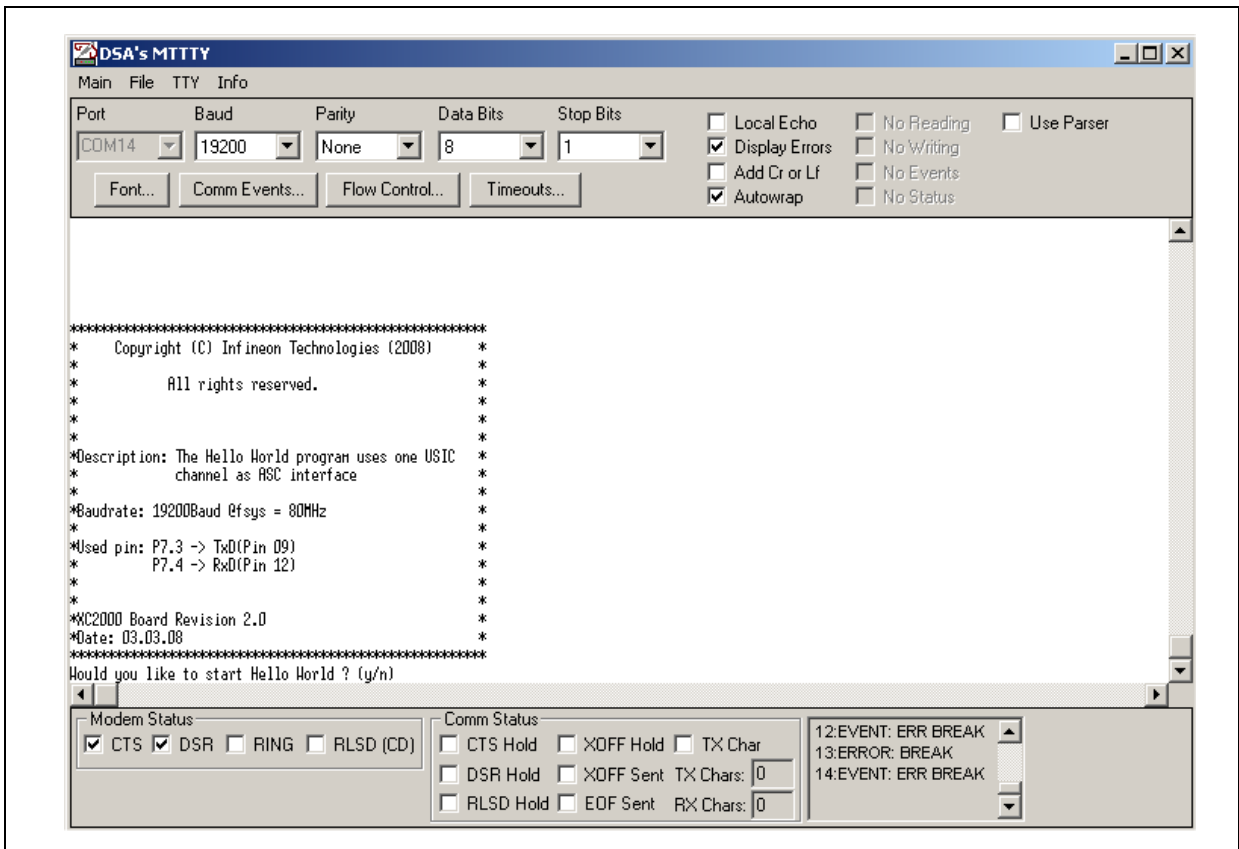

Figure 17 Monitor Program MTTY with Hello World program

4.1 Power Supply

If more current is needed, a regulated DC power supply with max. 12 Volts should be connected to the power connector. The maximum power dissipation of the used voltage regulator has to be taken into account. By default one green LED should be active. It indicates that the embedded voltage regulator supply the microcontroller.

Please Note, the power supply is not part of the delivery !

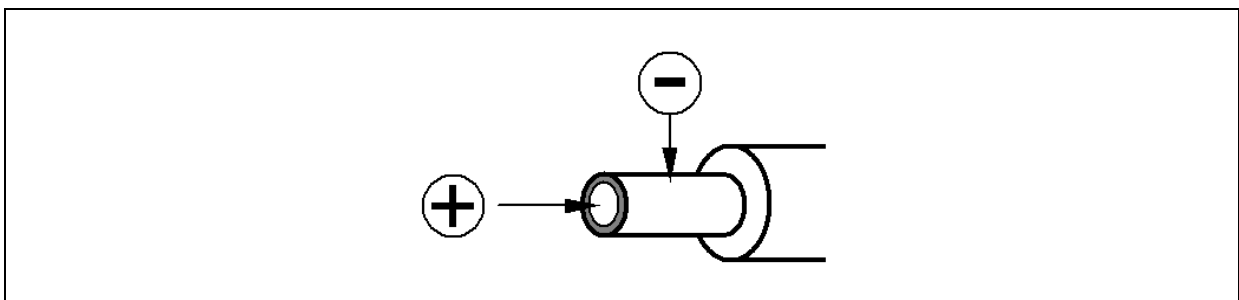

Figure 18 Power Supply Connector

4.2 OCDS Debugging Interface

The XE166 Easy Kit offers two types of JTAG interfaces. With the FTDI chip an on board USB JTAG wiggler has been implemented. Further the USB interface allows to emulate a USB to UART bridge. Both can be done at the same time.

A simple 16 pin JTAG header can be used to connect a debugger from one of Infineon's tool suppliers. Both systems include an On-Chip Debug Support (OCDS) system, which provides convenient debugging, controlled directly by an external device via debug interface pins.

4.3 USB Interface for UART support

The USB connector is used for connection to a PC. Via the USB it is possible to power the board, using the ASC0 as serial connection via USB and Debugging via DAS. For the pinout of USB socket see Figure 6.

NOTE: Before connecting the board to the PC, make sure that the actual DAS software is installed on the PC. For actual DAS software please contact your local FAE.

The latest version of the software can also be found on the

www.infineon.com/DAS

5 Schematic

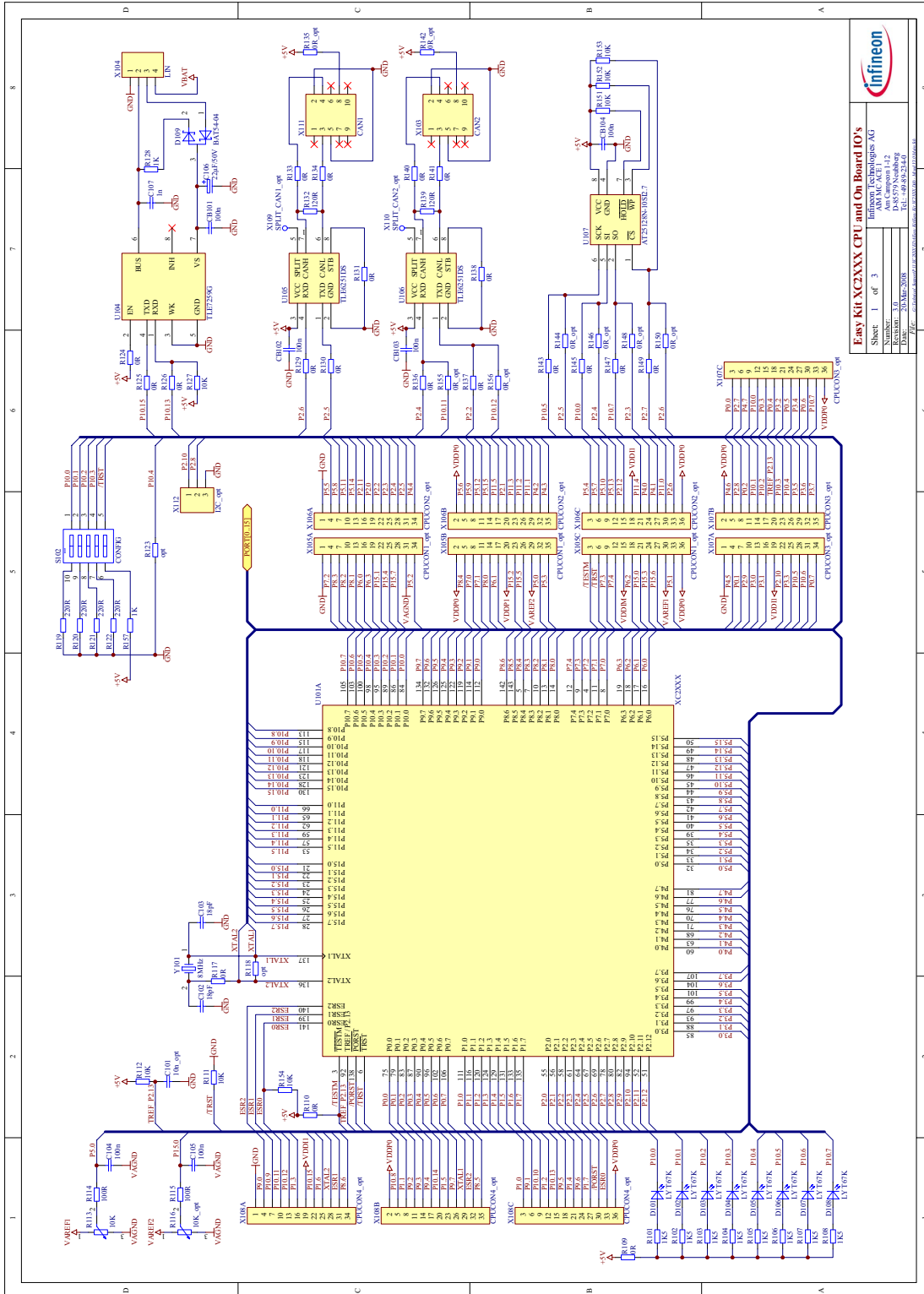

Easy Kit XC2XXX CPU and On Board IO's

Infineon Technologies AG
 Sheet: 1 of 3
 Number: 64982241
 Date: 2008-11-12
 Version: 1.0
 Author: 64982241
 Date: 2008-11-12
 File: ...

