

CHILLERS

TAEvo M05-M10

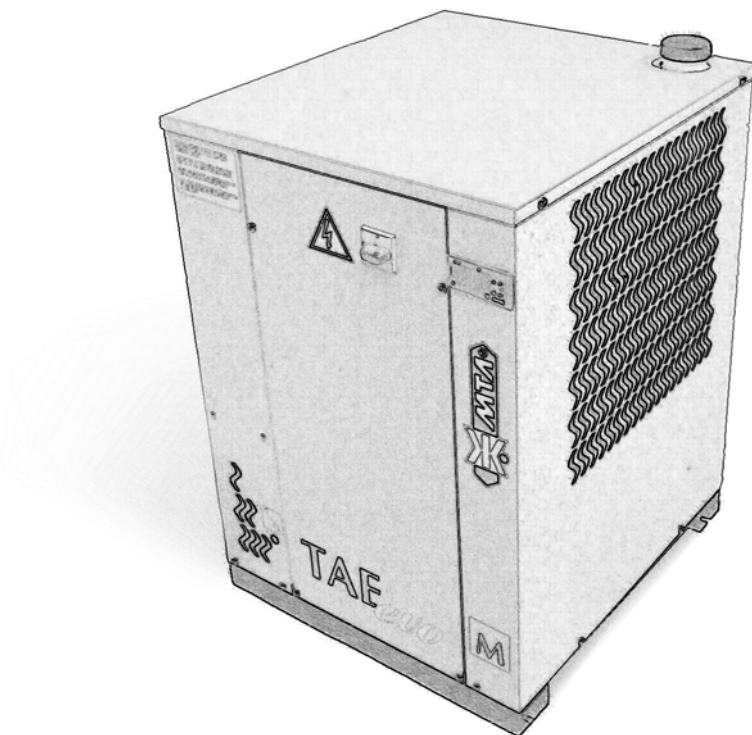

MAINTENANCE AND OPERATING MANUAL



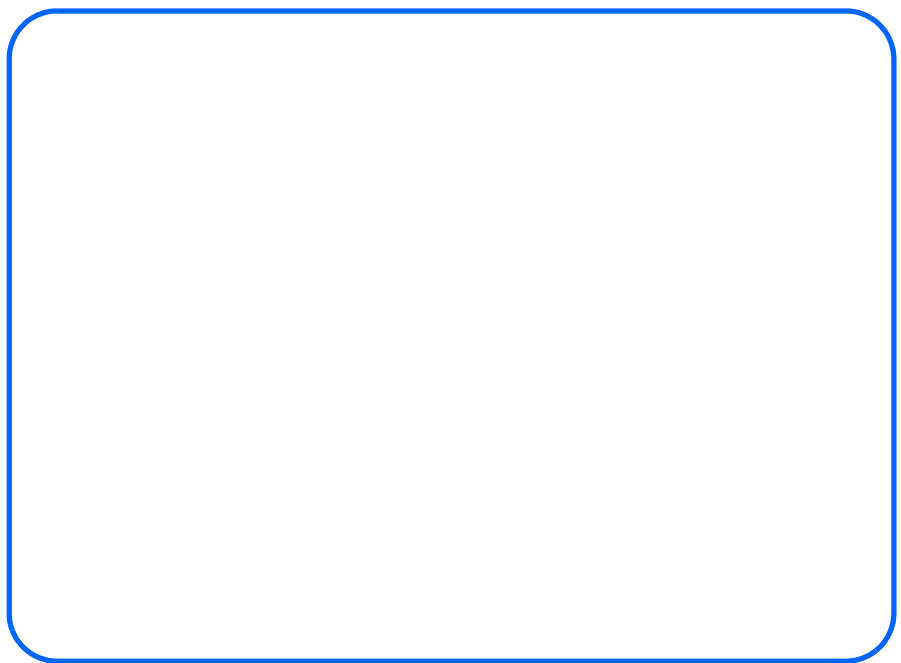

INDEX

- INDEX.....1**
- GENERAL INFORMATION2**
- 1.1 Terminology..... 2
- SAFETY.....3**
- 2.1 General..... 3
- 2.2 General precautions 3
- 2.3 Safety schedule 4
- TECHNICAL DATA.....6**
- 3.1 Data plate and meaning of abbreviations..... 6
- DESCRIPTION.....8**
- 4.1 Operating principle 8
- 4.2 Overall dimensions 8
- 4.3 Minimum distances from walls..... 8
- 4.4 Water and refrigerant circuits 8
- 4.5 Electrical circuit..... 9
- INSTALLATION.....9**
- 5.1 Inspection..... 9
- 5.2 Positioning 9
- 5.3 Antifreeze protection 9
- 5.4 Plumbing connections..... 10
- 5.5 Electrical connections 10
- START UP10**
- ELECTRONIC CONTROL BOARD.....11**
- 7.1 Introduction..... 11
- 7.2 User interface-key functions 11
- 7.3 Display 12
- 7.4 Automatic re-start 12
- 7.5 Compressor control..... 12
- 7.6 Storage temperature alarm 12
- 7.7 Alarms signalling..... 13
- 7.8 Unit general parameters 13
- 7.9 Digital input alarms 16
- 7.10 Other parameters..... 17
- 7.11 “iIF” parameter digital input 17
- HIGH PRESSURE SWITCH (HP)18**
- OPERATION AND MAINTENANCE18**
- 9.1 Operation 18
- 9.2 Maintenance..... 18
- TROUBLE SHOOTING20**



GENERAL INFORMATION

1.1 Terminology

The machines described in this manual are called “WATER CHILLERS” or simply “CHILLERS”. These chillers have been designed to cool a liquid flow.

In most applications, the liquid to be cooled is water and the term “WATER” will be used even if the liquid to be cooled is different from water (e.g. a mixture of water and glycol).

The liquid to be cooled must be compatible with the materials used.

This manual is written for those responsible for the installation, use and maintenance of the chiller.

Here below the term “PRESSURE” will be used to indicate the gauge pressure.

The following symbols are shown on the stickers on the unit as well as on the overall dimension drawing and refrigeration circuits in this manual. Their meaning is the following:







SYMBOL	DESCRIPTION	SYMBOL	DESCRIPTION
	Unit water inlet		Unit water outlet
	Indications for lifting the unit		Water drainage point from the machine
	Water filling point		Cooling air flow (for air-condensed units)
	Electric shock risk		Direction of the refrigerant fluid flow and water circuit

Table 1 SYMBOLS

1.1.1 Meaning of the code

The chillers described in this manual are defined by a code with a precise meaning.

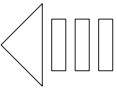
TAEevo Mxx:

Chiller with Tank, Air-cooled condenser, HErmetic compressor, M= single-phase power supply. The table below shows the nominal cooling capacity:

Model	Nominal cooling capacity (*) [W]
TAEevo M05	2500
TAEevo M10	4400

(*) Referred to the following operating conditions: water inlet 20°C, water outlet 15°C, ambient temperature 25°C.

ATTENTION

This manual provides the user, installer and maintenance technician with all the technical information required for installation, operation and carrying out routine maintenance operations to ensure long life.

If spare parts are required, this must be original.

Requests for SPARE PARTS and for any INFORMATION concerning the unit must be sent to the distributor or to the nearest service centre, providing the MODEL and MACHINE NUMBER shown on the machine data plate and on the first page of this manual.

CHAPTER 2

SAFETY

This machinery was designed to be safe in the use for which it was planned provided that it is installed, started up and maintained in accordance with the instructions contained in this manual.

The manual must therefore be studied by all those who want to install, use or maintain the machinery.

The machine contains electrical components which operate at the line voltage, and also moving parts as fans and/or pumps. It must therefore be isolated from the electricity supply network before being opened.

All maintenance operations which require access to the machinery must be carried out by expert or appropriately trained persons who have a perfect knowledge of the necessary precautions.

2.1 General

When handling or maintaining the unit and all auxiliary equipment, the personnel must operate with care observing all instructions concerning health and safety at installation site.

Most accidents which occur during the operation and maintenance of the machinery are a result of failure to observe basic safety rules or precautions. An accident can often be avoided by recognising a situation that is potentially hazardous.

The user should make sure that all personnel concerned with operation and maintenance of the unit and all auxiliary equipment have **read and understood** all warnings, cautions, prohibitions and notes written in this manual as well as on the unit.

Improper operation or maintenance of the unit and auxiliary equipment could be dangerous and result in an accident causing injury or death.

Do not operate the unit and auxiliary equipment until the instructions in the Operating section of this manual are understood by all personnel concerned. **Do not** carry out any servicing, repair or maintenance work on the unit and auxiliary equipment until the instructions in the relevant sections of this manual are clearly understood by all personnel concerned.

We cannot anticipate every possible circumstance which might represent a potential hazard. The warnings in this manual are therefore not all-inclusive. If the user employs an operating procedure, an item of equipment or a method of working which is not specifically recommended, he must ensure that the unit and auxiliary equipment will not be damaged or made unsafe and that there is no risk to persons or property.

ATTENTION

The hot / cold water produced by MTA units cannot be used directly for domestic hygiene or food applications. In the case of such applications, the installer is responsible for fitting an intermediate exchanger. If the intermediate exchanger is not fitted, the installer should affix a notice stating "non-drinking water".



2.2 General precautions

2.2.1 Liquids to be cooled

The liquids to be cooled must be compatible with the materials used.

These can be water or mixtures of water and glycol, for example. In case of distilled or demineralised water, check the compatibility with materials.

It is advisable to work with pH between 7 and 8. If using chemical additives consult your supplier for more information concerning compatibility with materials in contact with the process fluid of the chiller.

The liquids to be cooled must not be flammable.

ATTENTION

If the liquids to be cooled contains dangerous substances (e.g. ethylene glycol) it is very important to collect any liquid which leaks because it could cause damages to the ambient. Furthermore, when the chiller is no longer used, dangerous liquids must be disposed of by firms specialised and authorised for treating them.

2.2.2 Lifting and carriage precautions

Handling the chillers using fork-lift trucks must be carried out in accordance with the drawings in annexes: **TOC xxx**.

2.2.3 Installation precautions

For the connection to the electrical net see chapter "**Installation**".

2.2.4 Precautions during operation

Operation must be carried out by competent personnel under a qualified supervisor. All the cooled water or cooling water piping must be painted or clearly marked in accordance with local safety regulations in the place of installation.

ATTENTION

Never remove or tamper with the safety devices, guards or insulation materials fitted to the unit or auxiliary equipment.

All electrical connections must comply with local codes. The unit and auxiliary equipment must be earthen and protected by fuses against short-circuits and overloading.

ATTENTION

Do not open any electrical panels or cabinets while voltage.

2.2.5 Maintenance and repair precautions

Maintenance, overhaul and repair work must be carried out by competent personnel under a qualified supervisor.

ATTENTION

When disposing of parts and waste material of any kind make sure that there is no pollution of any drain or natural water-course and that no burning of waste takes place which could cause pollution of the air. Protect the environment by using only approved methods of disposal.

If replacement parts are needed use only original spares.

Keep a written record of all maintenance and repair work carried out on the unit and auxiliary equipment. The frequency and the nature of the work required over a period can reveal adverse operating conditions which should be corrected.

Use only refrigerant gas specified on the plate of the unit.

Make sure that all instructions concerning operation and maintenance are strictly followed and that the complete unit, with all accessories and safety devices, is kept in good working order.

The accuracy of temperature/pressure measuring devices must be checked regularly; renew measuring devices when the measurement tolerance is outside the specified range of values.

Keep the machine clean at all times. Protect components and exposed openings by covering them, for example, with clean cloth or tape during maintenance and repair work.

Do not weld or carry out any operation which produces heat near a system which contains oil or flammable liquids. The systems which may contain oil or flammable liquids must be completely drained and cleaned (with steam, for example), before carrying out these operations. Never weld, nor modify in any way, a vessel which may be put under pressure.

To prevent an increase in working temperature and pressure, inspect and clean heat transfer surfaces (i.e. condenser fins) regularly. For every unit establish a suitable time schedule for cleaning operations.

Avoid damage to safety valves and other pressure relief devices. Avoid plugging by paint, oil or dirt accumulation.

Precautions must be taken when carrying out welding or any repair operation which generates heat, flames or sparks. The adjacent components must always be screened with non-flammable material and if the operation is to be carried out near any part of the lubrication system, or close to a component which may contain oil, the system must first be thoroughly purged, preferably by steam cleaning.

Never use a light source with an open flame to inspect any part of the machine.

Before dismantling any part of the unit ensure that all heavy movable parts are secured.

When a repair has been completed, make sure no tools, loose parts or rags are left in, or on the machine.

All guards must be reinstated after carrying out repair or maintenance work.

Do not use flammable liquid to clean any component during operation. If chlorinated hydrocarbon non-flammable fluids are used for cleaning, safety precautions must be taken against any toxic vapours which may be released.

Before removing any panels or dismantling any part of the unit, carry out the following operations:

- Isolate the chiller unit from the main electrical power supply by disconnecting the cable from the electrical power source. Lock the isolator in the "OFF" position with a lock.
- Attach a warning label to the main isolator switch conveying: "WORK IN PROGRESS - DON NOT APPLY VOLTAGE". Do not switch on electrical power or attempt to start the unit if a warning label is attached.

Coloured tracers can be used in service-maintenance operations.

Inspect all refrigerant circuit joints including connectors, flanges, and more generally all critical points (open joints) in order to prevent possible leakage of refrigerant gas.

2.2.6 Refrigerant gases

R407C is used as refrigerant in these units.

Never attempt to mix refrigerant gases.

To clean out a very heavily contaminated refrigerant system, e.g. after a refrigerant compressor burnout, a qualified refrigeration engineer must be consulted to carry out the task.

The manufacturer's instructions and local safety regulations should always be observed when handling and storing high pressure gas cylinders.

2.3 Safety schedule

R407C	
Denomination:	23% Difluoromethane (R32); 25% Pentafluoroethane (R125); 52% R134a
INDICATION OF THE DANGERS	
Major dangers:	Asphyxia
Specific dangers:	Rapid evaporation can cause freezing
FIRST AID MEASURES	
General information:	Do not give anything to unconscious persons
Inhalation:	Take the person outdoors. Use oxygen or artificial respiration if necessary. Do not administer adrenaline or similar substances
Contact with the eyes:	Thoroughly wash with plenty of water for at least 15 minutes and call a doctor
Contact with the skin:	Wash immediately with plenty of water. Remove contaminated clothing immediately

R407C	
FIRE-FIGHTING MEASURES	
Means of extinction:	Any means
Specific dangers:	Pressure increase
Specific methods:	Cool the containers with water sprays
MEASURES IN THE EVENT OF ACCIDENTAL LEAKAGE	
Individual precautions:	Evacuate personnel to safe areas. Provide adequate ventilation. Use means of personal protection
Environmental precautions:	Evaporates
Cleaning methods:	Evaporates
HANDLING AND STORAGE	
Handling technical measures/ precautions:	Ensure sufficient air change and/or extraction in the work areas
recommendations for safe use:	Do not inhale vapours or aerosols
Storage:	Close properly and store in a cool, dry well-ventilated place. Store in its original containers. Incompatible products: explosives, flammable materials, organic peroxide
CONTROL OF EXPOSURE/INDIVIDUAL PROTECTION	
Control parameters:	AEL (8-h e 12-h TWA) = 1000 ml/m ³ for each of the three components
Respiratory protection:	For rescue and maintenance work in tanks, use autonomous breathing apparatus. The vapours are heavier than air and can cause suffocation, reducing the oxygen available for breathing
Protection of the eyes:	Safety goggles
Protection of the hands:	Rubber gloves
Hygiene measures:	Do not smoke
PHYSICAL AND CHEMICAL PROPERTIES	
Colour:	Colourless
Odour:	Similar to ether
Boiling point:	-43.9°C / -47.0°F at atm. press.
Flammability point:	Non flammable
Relative density:	1.138 kg/l at 25°C
Solubility in water:	Negligible
STABILITY AND REACTIVITY	
Stability:	No reactivity if used with the relative instructions
Materials to avoid:	Alkaline metal, earthy alkaline metals, granulated metals salts, Al, Zn, Be, etc. in powder.
Hazardous decomposition products:	Halogen acids, traces of carbonyl halides
TOXICOLOGICAL INFORMATION	
Acute toxicity:	(R32) LC50/inhalation/4 hours/lab. rats >760 ml/l (R125) LC50/inhalation/4 hours/lab. rats >3480 mg/l (R134a) ALC/inhalation/4 hours/lab. rats = 567 ml/l
Local effects:	Concentrations substantially above the TLV can cause narcotic effects. Inhalation of products in decomposition can lead to respiratory difficulty (pulmonary oedema)
Long-term toxicity:	Has not shown any cancerogenic, teratogenic or mutagenic effects in experiments on animals
ECOLOGICAL INFORMATION	
Global warming potential HGWP (R11=1):	R125: 0.84 - R134a: 0.28
Ozone depletion potential ODP (R11=1):	0
Considerations on disposal:	Usable with reconditioning

TECHNICAL DATA

3.1 Data plate and meaning of abbreviations

The main technical data are given on the machine data plate:

MODEL and CODE	The model number and the code identify the size of the unit (see Chapter 1 “General information”) and the type of construction.
MANUAL	This is the code number of the manual.
SERIAL NUMBER	This is the construction number of the unit.
MANUFACTURING YEAR	This is the year of the final test of the unit.
VOLTAGE/PHASE/ FREQUENCY	Electric alimentionation characteristics.
MAX. CONSUMPTION (I_{max})	This is electrical current consumed by the unit during the limit working conditions (refrigerant condensing temperature is 65°C = 149°F; refrigerant evaporating temperature is 10°C = 50°F).
INSTALLED POWER (P_{max})	It is the power absorbed by the unit during the limit working conditions (refrigerant condensing temperature is 65°C = 149°F; refrigerant evaporating temperature is 10°C = 50°F).
PROTECTION	As defined by the EN 60529 European standard.
REFRIGERANT	This is the refrigerant fluid in the unit.
REFRIGERANT QUANTITY	This is the quantity of refrigerant fluid contained in the unit.
MAX. COOLING PRESSURE	This is the design pressure of the refrigeration circuit.
MAX. COOLING TEMPERATURE	This is the design temperature of the refrigeration circuit.
USER CIRCUIT FLUID	Fluid cooled by the unit (normally water).
MAX. OPERATING PRESSURE	Max. design pressure of the user circuit.
MAX. TEMPERATURE	Design temperature of the user circuit; this should not be confused with the maximum working temperature which is established when the offer is made.
CONDENSER COOLING FLUID	Fluid used by the unit to cool the condenser (this data is not present if the unit is air cooled condensed).
MAX. OPERATING PRESSURE	Max. design pressure of the condenser cooling circuit (this data is not present if the unit is air cooled condensed).
MAX. TEMPERATURE	Max. design temperature of the condenser cooling circuit (this data is not present if the unit is air cooled condensed).
SOUND PRESSURE LEVEL	Sound pressure level in free field in hemispheric irradiation conditions (open field) at a distance of 1 m from the unit, condenser side, and at a distance of 1.6 m from the ground.
AMBIENT TEMPERATURE	Min. and max. cooling air temperature value.
WEIGHT	This is the approximate weight of the unit before packing.

Table 2 DATA PLATE AND MEANING OF ABBREVIATIONS

On the wiring diagram you will find the following abbreviations (see the first column in the table above):

I_{MAX}	max. electric current
P_{MAX}	max. power
I_{LR}	electric current with rotor stopped

ATTENTION

The performance of the refrigerant depends principally on the flow rate and temperature of the cooled water and on the temperature of the condenser cooling fluid (ambient temperature or water input temperature respectively, depending on whether the condenser is air or water-cooled). These data are defined in the offer and it is to these that reference should be made.

Other data for standard units:

TAEevo MODEL			M05	M10
Tank capacity		[litres]	25	25
P3 NoFe	water flow rate	[l/min]	8/40	8/40
	pump head	[bar]	4/0	4/0
	nominal power	[kW]	0,33	0,33
	type		peripheric	

Table 3 PERFORMANCES

NOTE

Standard pumps are of peripheral type, so the pump heads indicated in the table are respectively at no flow and at max. flow. It is possible for the pump installed to be different from the standard one. In this case reference should be made to the data in the offer.

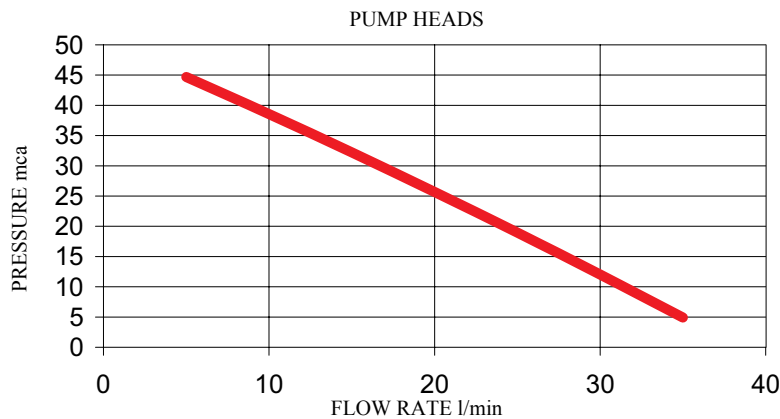

NOTE

The pump must never run dry.

3.1.1 Sound Level Measurements

	Lp dB(A) *	Lw dB(A) **
TAEevo M05	63,3	76,3
TAEevo M10	63,3	76,3

* at distance of 1 metre (3,2 FT)

** global

Test conditions

Noise levels refer to operation of the unit at full load in nominal conditions.

Sound pressure level in hemispherical irradiation conditions at a distance of 1 m (3,2 FT) from the condenser side of the unit and height of 1.6 m (5,2 FT) from the ground. Values tolerance ± 2 dB.

Sound power level: in compliance with ISO 3744

3.1.2 Limit operating conditions

		Minimum	Maximum
Ambient air temperature	°C	5	40
Evaporator water inlet temperature	°C	5	35
Evaporator water outlet temperature	°C	0(1)	30

(1) For temperatures below +5°C use antifreeze solutions (see 5.3 “Antifreeze protection”).



DESCRIPTION

4.1 Operating principle

All the chillers described in this manual work on the basis of the same principle. A refrigerant circuit cools the exchange surface of an evaporator through which the liquid to be cooled passes.

The evaporator finds inside the tank.

The refrigerant compressor is controlled by an electronic control unit.

The electronic control unit controls the temperature of the water in the tank to maintain it within preset limits.

Also consult **Chapter 7 “Electronic control board”**.

4.1.1 Compressor

Hermetic or rotary type, cooled by the aspirated refrigerant and equipped with thermal cutout protection.

The compressor is mounted on anti-vibration supports.

4.1.2 Casing

Built with galvanised panels and painted with epoxy resins.

The panels have no structural function so that they can easily be removed to permit total access to all the components.

4.1.3 Materials in contact with the liquid to be cooled

Stainless steel, copper, brass, plastics.

4.1.4 Condenser and fan

Air cooled condensers are used without steel tubes; in this case it is the fins that form the tube by means of long collars inserted one inside the other and brazed with copper in a controlled atmosphere oven. The condensing coils are equipped with an axial fan complete with protective grille. The fan is of the “pressure” type: the air is drawn from the interior of the unit and expelled into the atmosphere, flowing through the condensing coil along its route.

4.1.5 Evaporator

Consisting of a copper tube in tube exchanger. The water flows in counter-current to the evaporating refrigerant.

4.1.6 Pump

Of peripheric type, body in brass/bronze, impeller in brass, shaft in stainless steel.

ATTENTION

If the pump would clump, follow the instructions in paragraph 9.2.2 “Unjamming the pump”

NOTE

The pump must never run dry.

4.1.7 Accumulation tank

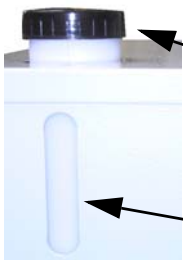

A In these units are used stainless steel accumulation tanks.

TAEevo M are furnished with cylindrical tank, finding in vertical position over the unit's base.

The tanks, hermetically closed, contain the evaporator.

The hydraulic circuit is of atmospherical type and by a plastic receptacle with a capacity of about 1,5 litres, complete with a plug (A), it is possible to fill the unit.

B This receptacle is fixed to the machine casing in which there is a slot (B) for inspecting the water level and a hole which permits access to the filling plug from the outside.

4.2 Overall dimensions

See enclosures RED xxx

4.3 Minimum distances from walls

See enclosures RED xxx

4.4 Water and refrigerant circuits

See enclosures REF xxx

4.4.1 Water circuit

The water flowing through the evaporator pipes cools and flows into the tank.

Then the water is sucked by a peripheric pump which sends it directly to the user.

The pump delivery is connected to the evaporator by a **by-pass pipe** which guarantees a minimum water flow through the pump should a pipe at any point of the hydraulic circuit be closed by mistake.

A pressure gauge is connected to the pump output. It indicates the outlet water pressure of the plant.

4.4.2 Refrigerant circuit

The refrigerant is pumped by the refrigerant compressor to the condenser. The condenser is a heat exchanger and is cooled by an air flow produced by a fan.

After the condenser, the refrigerant liquid passes through a drying filter and a laminating element (capillary tube).

The refrigerant then enters the evaporator's circuit in which it flows in counter-current with respect to the water to be cooled.

When it exits the evaporator, the refrigerant is again sucked by the compressor and the cycle repeats itself.

The refrigerant circuit is also furnished with a high pressure switch (HP) of manual reset type.

4.5 Electrical circuit

See the enclosed electrical diagrams.

CHAPTER 5

INSTALLATION

ATTENTION

Before carrying out the installation or operating on this machine, ensure that all the personnel has read and understood the "Safety" chapter in this manual.

5.1 Inspection

Immediately after uncrating, inspect the unit.

5.2 Positioning

1. The chiller must be installed indoors only.
2. The room must be well ventilated. In some cases it may be necessary to install fans or extractors to limit the temperature of the room.
3. The ambient air must be clean and not contain flammable gas or solvents. The minimum and maximum working ambient temperatures are specified on the unit data plate. In extreme temperature conditions, the protection devices may trip.
4. The machine can be positioned on any flat surface capable of supporting its weight.
5. Leave at least one metre in front of the unit to permit access during service operations (see chapter 4.2 "Overall dimensions").
6. Do not obstruct or disturb the condenser's flow of cooling air. **Position the chiller in such a way that the cooling air cannot recirculate in the intake grilles.** Ensure that the chiller is not subject to warm air from the cooling systems of other machines.

5.3 Antifreeze protection

Even if the minimum working ambient temperature is above 0°C it is possible for the chiller - during stoppages in the cold seasons - to find itself in an environment with a temperature below 0°C. In these cases, if the chiller is not emptied, antifreeze (ethylene glycol) must be added in the following percentages to prevent the formation of ice:

Ambient temperature up to [°C]	Ethylene Glycol [% in weight]
0	0
-5	15
-10	25
-15	30
-20	40

According to the outlet temperature of cooled water, it is necessary to add the following antifreeze (ethylene glycol) percentages in order to avoid freezing:

Water outlet minimum temperature [°C]	Ethylene Glycol [% in weight]
0<T	15

5.4 Plumbing connections



It is recommended to insert a filter of “Y” type on the water inlet connection, in order to stop eventual impurities of water which could cause big damages to the pump.

1. Connect the chiller to the water piping. See the overall dimension drawings for the size and type of connections.
2. Provide two cocks (inlet and outlet) to by-pass the machine for maintenance purposes without having to empty the water circuit of the user.
3. Fill the water receptacle by unscrewing the plug of the receptacle and filling the circuit with water (for example using a hose connected to the cock) until the level in the receptacle is about half-way up the slot. The filling of tank before starting-up the unit is very important as the pump can not operate without water.

The receptacle used for filling the circuit acts as an open expansion tank. It is therefore necessary to pay attention to the volumes and dimensions in play.

5.5 Electrical connections

Check that the power supply voltage and frequency match the requirements of the unit as shown on the unit data plate and they are within the tolerances given in the wiring diagram.

Ensure that the electrical installation complies with local wiring and safety regulations.

Check that there is a neutral line in the electrical installation and it is earthen in the transformer cabin (TN system in compliance with IEC 364 - HD 384 - CEI 64-8) or that this is done by the electricity supply company (TT system).

The electrical supply cable must be connected to the electrical installation and pay attention to connect the neutral wire of the unit (indicated by the appropriate colour) to the neutral wire of the installation.

The electrical supply cable must be the one supplied with the unit and/or indicated in the electrical wiring diagrams.

At the beginning of the electrical supply cable

1. must be guaranteed a protection against direct contacts with a protection degree of IP2X or IPXXB at least;
2. must be installed protection devices that:
 - protect against overcurrents, the power supply cable and the cables not protected by the electrical plant of the machine; (see information in the electrical wiring)
 - limit the 17 kA peak short circuit current to its own nominal cut-off power when the short circuit current at the operation point is higher than 10 kA effective;
 - protect against indirect contacts on the unit, (such as short-circuiting between the phase and protection circuit) by cutting off the supply automatically (see IEC 364 - HD 384, CEI 64-8);
Use a differential switch (normally with operation nominal differential current of 0.03 A)
 - protect against phase failures where the electrical supply is three-phase.

For protection circuit dimensions, please refer to the data specified in the wiring diagrams attached (max. absorption, pick-up currents, cables section).

CHAPTER 6

START UP

ATTENTION

Before starting up or operating these units be sure that all personnel have read and understood the “Safety” section of this manual.

1. Check that the machine's on/off valves are open.
2. Check that the level of the liquid in the receptacle is at about the middle of the graduated scale.
3. Check that the ambient temperature is within the limits indicated on the machine data plate.
4. Check that the main switch is in the OFF position (“O”).
5. Check that the power supply voltage is correct.
6. Turn the machine main switch ON (“I”). The display lights on to indicate the presence of tension.



7. The pump is not ready to start.

If with the first start-up, there is a high ambient temperature and the temperature of the water in the hydraulic circuit is much higher than the working value (e.g. 25-30°C) this means that the chiller starts up overloaded with the consequence of **possible tripping of the compressor**

protection devices. To reduce this overload, a chiller outlet valve can be gradually (but not totally!) closed to reduce the flow of water passing through it. Open the valve as the water temperature in the hydraulic circuit reaches the working value.

If the thermal load is lower than that produced by the chiller, the water temperature drops until it reaches the set point.

With operating pump, if the unit is in normal operation, the water should be at mid-slot in the receptacle.

CHAPTER 7

ELECTRONIC CONTROL BOARD

7.1 Introduction

The main function of the electronic control board are:

- complete management of the alarms;
- control of the temperature at evaporator outlet.

The electronic control board allows to control the following devices:

- pump;
- compressor;
- alarm signalling devices.

7.2 User interface-key functions



Key	Action	Function
SET	Pressed once	The set-point will be displayed
	Pressed for 3 seconds	Chiller set-point modification, the °C LED flashes, use keys to change the set-point. To save the parameter press key or simply wait 15 sec.
	Pressed once	Shows maximum temperature value In the programming phase scrolls through the parameter codes or increases their value
	Pressed once	Shows minimum temperature value In the programming phase scrolls through parameter codes or decreases their value
	Pressed once	Switches device on/off
	Pressed once	Starts a defrost cycle (not active function)

7.2.1 Key combinations

Key	Function
+	Lock/ unlock the keypad: Hold down both keys until the message "POF" is displayed. Repeat the procedure to unlock, the message "Pon" is displayed
SET +	To access the hidden menu: Open programming mode by holding down the key combination for 3 seconds (access is granted to Pr1 parameters); In programming mode (Pr1) press the key combination for at least 7 seconds: the message "Pr2" is displayed (access is granted to Pr2 parameters in the hidden menu) Each parameter can be moved from Pr2 to Pr1 and vice versa.
SET +	To quit the programming area

7.2.2 MEANING OF LEDs

The table below describes the LED functions:

LED	MODE	MEANING
❄	on	Compressor running
❄	Flashing	Time lag between consecutive compressor starts
❄	on	Defrost in progress (Not active function)
❄	Flashing	Dripping in progress (Not active function)
🌀	on	Fans running (Not active function)
🌀	Flashing	Fan start delay in progress
🔊	on	Temperature alarm
🔄	on	Continuous cycle in progress
☀	on	Energy saving in progress (Function not active)
°C / °F	on	Unit of measurement
°C / °F	Flashing	Programming

NOTE

(*) the new value set is saved also when quitting without pressing the SET key.

7.3 Display

The display is composed of 3 digits. Temperature detected by probe (-BT1) is displayed with decimal resolution, the field of display is: -50÷110°C (-58÷230°F).

7.4 Automatic re-start

After a loss of power, the unit will re-start automatically if it was ON, observing the selected operating modality, but not if it was OFF before the loss of power.

7.5 Compressor control

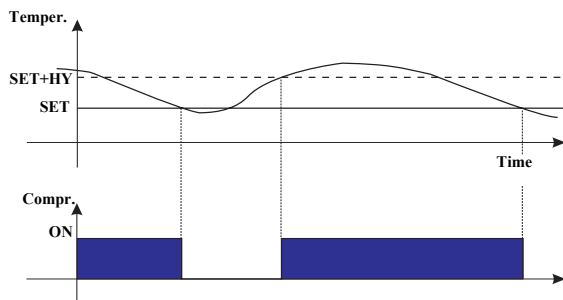

The compressor relay is activated to maintain a given temperature value established by the set-point. Hysteresis Hy is automatically added to the set-point. If the temperature value increases and reaches the set-point + hysteresis value, the compressor is started and then stopped when the temperature value returns to the set-point value. If the probe (-BT1) develops a fault, the activation or deactivation of the output are managed by time by means of the parameters "CO_n" and "CO_F".

7.6 Storage temperature alarm

To view the minimum temperature reached:

Press , the message "Lo" is displayed followed by the minimum temperature reached.

To view the maximum temperature reached:

Press , the message "Hi" is displayed followed by the maximum temperature reached.

To delete the maximum or minimum temperature reached:

When the stored temperature value is displayed, hold down key  for several seconds (the flashing message "rSt" is displayed).

7.7 Alarms signalling

Message	Cause	Outputs
P1	Thermostat probe (-BT1) faulty	Compressor output according to parameters “CO _n ” and “CO _F ” (alarm relay changeover)
P2	Evaporator probe faulty	Defrost by time (function not active)
HA	High temperature alarm	Not modified (alarm relay changeover)
LA	Low temperature alarm	Not modified (function not active, alarm relay changeover)
EA	External alarm	Not modified (alarm relay changeover)
CA	High pressure switch alarm (HP) (i1F=bAL)	Loads off (alarm relay changeover)
dA	Door open	Loads according to “odC” (alarm relay changeover)
CA	Pressure switch alarm (i1F=PAL)	Loads off (alarm relay changeover)

The “P1” and “P2” probe alarms trip few seconds after the probe develops a fault; they switch off automatically few seconds after the probe starts to function properly. Before renewing the probe check the connections.

The “HA” and “LA” temperature alarms switch off automatically as soon as the thermostat temperature returns to normal.

The external EA and CA alarms switch off as soon as the digital input is deactivated.

If the I.D. is configured as a pressure switch (i1F=bAL) the reset is performed manually by switching off the instrument.

7.8 Unit general parameters

The unit is factory-equipped with preset parameters, which are values calculated for standard applications. If it becomes necessary to edit the values of any of the general parameters, we recommend contacting your Service Centre.

Failure to observe this prescription exposes the user and unit to potential risks.

ATTENTION

The manufacturer declines all possible warranty claims concerning performances and safety standards following arbitrary modification of the parameters by the user.

7.8.1 Control parameters

Visible parameters

The visible parameters are set during the design stage. If it becomes necessary to make a hidden parameter visible, follow the procedure described in chapter 7.2.2 “MEANING OF LEDs”

Parameter		Description	Min.	Max.	U.M.	Factory settings
Set	Set-point	The setting for water temperature at the unit outlet	-50	110	°C	7
Hy	Hysteresis	Set-point trip differential. The hysteresis value is added to the set-point: the relay is energised when the temperature reaches the set-point + hysteresis value and de-energised when the temperature returns to the set-point value.	0,1	25	°C	4
LS	Minimum set-point value	Establishes the set-point minimum value.	-50	SET	°C	0
US	Maximum set-point value	Establishes the set-point maximum value.	SET	110	°C	30
Ot	Thermostat probe calibration	Serves to calibrate the thermostat probe	-12	12	°C	0
P2P	Evaporator probe presence	Serves to set the evaporator probe: n= not present Y= present.				n
OE	Evaporator probe calibration	Serves to calibrate the evaporator probe	-12	12	°C	0

Table 4 CONTROL PARAMETERS

Parameter		Description	Min.	Max.	U.M.	Factory settings
OdS	Power on outputs activation delay	At the time of power-on activation of all loads is inhibited for the time set	0	255	min	0
AC	Anti-hunting delay	Minimum interval between compressor stop and successive start	0	50	min	6
CCt	Continuous cycle duration	To set the continuous cycle duration, to be used for example when filling the cold store with new products.	0	24 h	°C	0
CCS	Continuous cycle set-point	This set-point is used during the continuous cycle	-50	150	°C	-5
CO _n	Compressor On time with faulty probe	Time for which the compressor continues to run in the presence of a probe fault CO _n =0 the compressor always remains stopped (*) (*) If CO _n =0 and "COF" _n =0 the compressor is stopped	0	255	min	0
COF	Compressor Off time with faulty probe	Time for which the compressor remains stopped in the presence of a probe fault COF=0 the compressor is always on	0	255	°C	0

Table 4 CONTROL PARAMETERS

7.8.2 Display

Parameter		Description	Min.	Max.	U.M.	Factory settings
CF	Temperature unit of measurement	Serves to set the unit of measurement. If the unit of measurement is changed the following parameters must be reset: Hy, LS,US, Ot, ALU, ALL			°C≠°F	°C
rES	Resolution	Allows the decimal point to be displayed in=1°C dE=0,1°C				dE
Lod	Display	Select the probe to be displayed P1= thermostat probe P2= evaporator probe P3= probe (P3 not active) P4= probe (P4 not active) Set= set-point dtr= display percentage				P1
dLy	Temperature display time lag	As the temperature rises the displayed value increases by 1 degree Celsius or Fahrenheit every dLy minutes.	0	20.0	min	0

7.8.3 Defrost parameters (function not active)

Parameter		Description	Min.	Max.	U.M.	Factory settings
tdF	Type of defrosting	Serves to choose the type of defrosting El= heater in= hot gas				El
dtE	Defrost End Temperature	Establishes the evaporator temperature that determines the end of the defrost cycle.	-50	50	°C	8
ldF	Defrost cycles interval	Establishes the interval between the start of two defrost cycles	0	120	h	6
MdF	Defrost duration	Establishes maximum defrost duration <ul style="list-style-type: none"> P2P= n no evaporator probe (time controlled defrosting) establishes the defrost duration time P2P= y (defrost end at temperature) becomes the maximum defrost duration (*) 0 inhibit defrost cycle	0	255	min	0
dSd	Defrost start delay	Serves to diversify defrost starts avoiding system overloads	0	59	min	0



Parameter		Description	Min.	Max.	U.M.	Factory settings
dFd	Temperature displayed during defrosting phase	Serves to set temperature display <ul style="list-style-type: none"> • rt= real temperature • it= defrost start temperature • set= set-point • dEF= message “dEF” 				dEF
dAd	Max display delay after defrost	Establishes the maximum time interval between the defrost end and the restoration of the cold store temperature display	0	120	min	30
Fdt	Drip time	Time interval between defrost end temperature and the start of normal operation.	0	120	min	2
dPO	First defrost after start	Establishes the defrost function start mode <ul style="list-style-type: none"> • y= immediate • n= after time interval ldF 				n
dAF	Delay on defrost after freezing	Time interval between freezing procedure end and the next associated defrost cycle	0	23h 50min	min	0

7.8.4 Fans

Parameter		Description	Min.	Max.	U.M.	Factory settings
FnC	Fans operating mode.	Serves to set the fans operating mode. <ul style="list-style-type: none"> • C-n= in parallel with the compressor; off in defrost phase • o-n= continuous, off in defrost phase • C-Y= in parallel with compressor; on in defrost phase • o-Y= continuous, on in defrost phase 				C-n
Fnd	Start delay after defrost	Time interval between defrost end and fans start.	0	255	min	0
Fct	Temperature differential	If the temperature difference between the evaporator probe and the cold store probe is higher than the value set in Fct, the fans always run	0	59		0
FSt	Fans stop temperature	If temperature detected by the evaporator probe is higher than “FSt” the fans are stopped	-50	50	°C	0
Fon	Fans start time with compressor off	With the compressor off, if the temperature conditions are present, the fans are activated cyclically according to the times set in Fon and FoF. With Fon= 0 and FoF≠ 0 the fans are always off, with Fon= 0 and FoF= 0 the fans are always off.	0	15	min	0
FoF	Fan stop time with compressor off	With the compressor off, if the temperature conditions are present, the fans are activated cyclically according to the times set in Fon and FoF. With FoF= 0 and Fon≠0 the fans are always on, with Fon= 0 and FoF= 0 the fans are always off.	0	15	min	0

7.8.5 Parameters relative to alarms management

Parameter		Description	Min.	Max.	U.M.	Factory settings
ALC	Temperature alarms configuration	Serves set temperature alarms on the basis of: <ul style="list-style-type: none"> • Ab= absolute temperature (in relation to parameters ALL and ALU) • rE= relative to the SET (in relation to “SET+ALU” or “SET-ALL” value settings) 				Ab
ALU	High temperature alarm	When this temperature is reached the alarm is signalled	ALL	110	°C	40
ALL	Low temperature alarm	When this temperature is reached the alarm is signalled	-50,0	ALU	°C	3

Table 5 PARAMETERS RELATIVE TO ALARMS MANAGEMENT

Parameter		Description	Min.	Max.	U.M.	Factory settings
ALd	Temperature alarm delay	Time interval between detection of a temperature alarm and relative signalling	0	255	min	0
dAO	Temperature alarm inhibit at start-up	At start-up of the unit the temperature alarm is inhibited for the time set in this parameter	0	23,5 h	10 min	0
tbA	Alarm relay deactivation	n= relay active for the entire duration of the alarm y= the relay is deactivated by pressing with an alarm in progress				n
AoP	Polarity according to relay (oA3=ALr)	Selects alarm relay open or closed during an alarm. cl = terminals 1-2 closed during an alarm; op = terminals 1-2 open during an alarm				oP

Table 5 PARAMETERS RELATIVE TO ALARMS MANAGEMENT

7.9 Digital input alarms

Parameter		Description	Min.	Max.	U.M.	Factory settings
i1P	Digital input polarity	Serves to set alarm signalling on the basis of: <ul style="list-style-type: none"> oP= input is activated by contact opening CL= digital input is activated by contact closing 				oP
i1F	Digital input configuration	Serves to set alarm signalling on the basis of: <ul style="list-style-type: none"> EAL= external alarm (EA on display) bAL= critical alarm PAL= pressure switch alarm dor= door microswitch dEF= defrost activation AUS= not enabled Htr= reverse action (hot-cold) FAN= not enabled ES= not enabled OFb= not enabled 				bAL
did	Digital input alarm delay	Serves to set the time lag before activation of the digital input alarm <ul style="list-style-type: none"> i1F=EAL or bAL delay between detection and signalling of an external alarm i1F=dor delay on door open alarm signal i1F=PAL time for pressure switch operation: if nPS activations in time did are reached restarting is manual only by powering off the unit and then powering it on again 	0	255	min.	0
nPS	Number of pressure switch activations	At each activation of the digital input the control is blocked; if nPS activations are reached in time did restarting is manual only by powering off the unit and then powering it on again.	1	15		15
odc	Door open control	Determines compressor and fan status with door open <ul style="list-style-type: none"> no= fans and compressor operate normally Fan= fans OFF CPr= compressor OFF F-C= compressor and fans OFF 				F-C

7.10 Other parameters

Parameter		Description	Min.	Max.	U.M.	Factory settings
Adr	Serial address	Serial address	0	244		1
Pbc	Probe type selection	Serves to select the type of probe present on the unit <ul style="list-style-type: none"> • Ptc= Ptc probe • ntc= ntc probe 				ntc
dP1	Thermostat temperature probe	Displays thermostat probe temperature.				
dP2	Evaporator temperature probe	Displays evaporator probe temperature.				noP
onF	Keypad control	Serves to enable or disable the ON/Off function from the keypad <ul style="list-style-type: none"> • n= On/Off not active • y= On/Off active 				y
Ptb	Parameters table	Serves to identify the map of set parameters				1
rEL	Software release	Specifies the controller version				7.4

7.11 "i1F" parameter digital input

Parameter "i1F" relative to the digital input offers several possible configurations

Parameter		Description
i1F=dor	Door microswitch	Signals that the cold store door has been opened. When the door is opened the compressor and fans are controlled on the basis of the value of parameter "odc" (see 7.8.5 "Parameters relative to alarms management"). After the time set for parameter "did" a door open alarm is generated and the message "dA" is shown on the display. The alarm terminates automatically as soon as the digital input is deactivated. Temperature alarms are inhibited when the door is open.
i1F=EAL	External alarm	An alarm is generated after the delay set by parameter "did" from activation of the input an alarm is generated; the message "EA" is displayed and the status of the outputs is not changed. The alarm switches off automatically as soon as the digital input is deactivated.
i1F=bAL	High pressure switch alarm (HP)	After a delay set by parameter "did" from activation of the input an shut-down alarm is generated; the message "CA" is displayed and the control relay outputs are deactivated. The alarm switches off automatically as soon as the digital input is deactivated.
i1F=PAL	Pressure switch trip	If, in the time interval established by the "did" parameter a number of pressure switch trips is reached equivalent to the number set in parameter "nPS", the alarm will be triggered. The message "CA" is displayed, the compressor is stopped and control suspended. To resume normal operation switch off the instrument and then switch it on again. When the input is active the compressor is always stopped.
i1F=dEF	Defrost cycle start	Function not present
i1F=AUS	-	Function not present
i1F=FAN	-	Function not present
i1F=Htr	Action reversal Cold- Hot	Function not present
i1F=ES	Energy Saving function	Function not present
i1P=CL	Digital input polarity	The polarity of the digital input depends on parameter i1P i1P=CL : active with closed contact i1P=oP : active with open contact



HIGH PRESSURE SWITCH (HP)

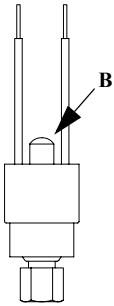

TAEvo M05 - M10 models are furnished with a high pressure switch (HP).

It monitors the discharge pressure of the refrigerant compressor and prevents it from increasing to dangerous levels for the compressor and people within the immediate vicinity.

It is of “manual reset” type. It opens the power circuit of the compressor and of the fan (see wiring diagram). When the discharge pressure of the refrigerant compressor decreases and falls below the reset point, it resets. Therefore it is necessary to manually restart it to start the unit (press the reset button on the top part of the cover **B**).

The setting values are fixed.

In the event of replacement, the pressure switch is screwed to a SCHRAEDER valve which prevents the refrigerant from leaking.

The TRIP and RESET values of the pressure switch are indicated in the following table:

Pressure switch	Refrigerant	TRIP			RESET		
		bar	°C	°F	bar	°C	°F
HP	R407C	27.5	63.9	147	19.2	48.9	120

Table 6 SETTING OF HP PRESSURE SWITCH

OPERATION AND MAINTENANCE

9.1 Operation

The machine operates in completely automatic mode.

There is no need to turn it off when there is no thermal load as it turns off automatically when the preset water temperature has been reached.

9.2 Maintenance

ATTENTION

Before proceeding with the maintenance of these units be sure that all personnel concerned have read and understood the “Safety” section of this manual.

9.2.1 Unit access

To access the components of the refrigerant circuit, remove the front panel “A” and then the unit cover “B”. After removing the front panel “A” it is possible to access also the electrical panel. To access the pump and part of the hydraulic circuit, remove the lower side panel “C” of the unit.

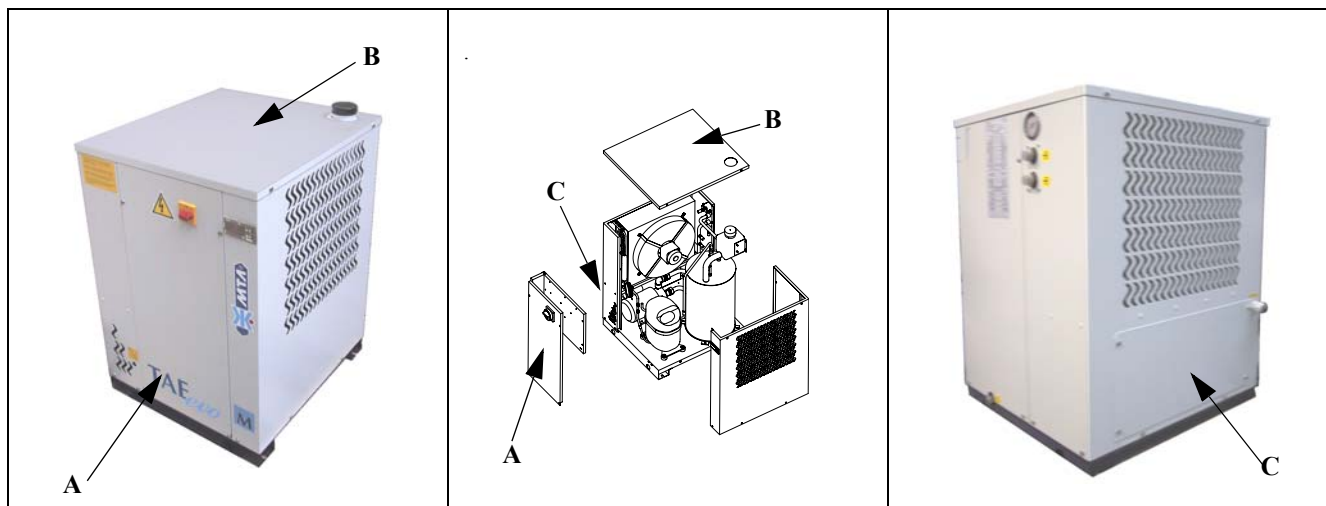

9.2.2 Unjamming the pump



The pump body is made of bronze and the impeller is made of brass. These materials do not oxidize, therefore they will not tend to seize. However the sealing surfaces may on rare occasions tend to stick. In this case the pump can be unjammed without removing any panels. For this purpose there is a hole in the front panel (see figure) where, with the aid of a screwdriver, it is possible to nudge the pump shaft directly.

ATTENTION

This operation must be performed whenever the pump appears to be jammed.

NOTE

The pump must never run dry.

9.2.3 Maintenance Schedule

OPERATION	1 day	1 month	6 months	annually
Check control panel display for any alarm signals.	•			
Check that the water output temperature is within the envisaged range.	•			
Check that the water intake temperature is lower than the value used for selecting the chiller.	•			
Check that the ambient temperature is lower than the value used for selecting the chiller. Check that the environment is well ventilated.		•		
Check the level of water in the filling tank from the slot in the outer casing.	•			
Check that the unit current absorption is with the value on the data plate.		•		
Carry out visual inspection of refrigerant circuit, looking out for any deterioration of the piping or any traces of oil which might indicate a refrigerant leak.			•	
Check the condition and security of piping connections.			•	
Check the condition and security of wiring and electrical connections.			•	
Check that fan operation is not noisy. Thoroughly clean the fins of the condenser with soft sponge and/or jet of clean compressed air. Check that the grilles of the unit are free from dirt and any other obstructions.			•	

Table 7 MAINTENANCE SCHEDULE

ATTENTION

*This plan is based on an average working situation.
In some installations it may be necessary to increase the frequency of maintenance.*



TROUBLE SHOOTING

PROBLEM	CAUSE	SYMPTOM	REMEDY
A Water temperature higher than the expected value.	A1 Thermal load too high.	A1.1 Water temperature higher than expected value.	Restore the thermal load to within the preset limits.
	A2 Ambient temperature too high.	A2.1 See A1.1	Restore the ambient temperature to within the preset limits.
	A3 Condenser fins dirty.	A3.1 See A1.1	Clean the condenser fins.
	A4 Front surface of the condenser obstructed.	A4.1 See A1.1	Free the front surface of the condenser.
	A5 No refrigerant fluid in the plant.	A5.1 • See A1.1 • low evaporation pressure.	Get a technician to check for leaks and eliminate them. Fill the plant.
B Probe (-BT1) faulty	B1 Probe faulty or parameters out of range.	B1.1 Message P1 appears.	Check or renew the probe.
C Low water pressure at pump outlet.	C1 Clearance between the impeller and the pump casing too high. Wear parts.	C1.1 Low water pressure at pump outlet.	Verify and replace the pump impeller.
D The chiller is obstructed and the water does not flow.	D1 Set point too low so that the water freezes.	D1.1 • Water does not pass; • intake pressure too low.	Choose between: • Raise the set point; • add an appropriate % of ethylene glycol (antifreeze) (see Chapter 5 "Installation").
	D2 Evaporator obstructed by dirt carried by the water to be cooled.	D2.1 High water temperature difference between inlet and outlet.	Depending on the type of dirt: • clean the evaporator by running a detergent solution which is not aggressive for steel, aluminium and copper; • run a high water flow against the stream. Install a filter upstream from the chiller.
E High pressure switch (HP) trips	E1 Fan does not work.	E1.1 The compressor and the fan stop	Repair or replace the fan. Where fitted, check the thermal protection switch of the fan. Press the reset button on the cap of the pressure switch.
	E2 Ambient air temperature too high.	E2.1 • Air ambient temperature higher than maximum permitted value; • See E1.1 .	Reduce ambient temperature within design limits, for example by increasing local ventilation. Press the reset button on the cap of the pressure switch.
	E3 Recirculation of warm air due to incorrect installation location.	E3.1 • Condenser cooling air temperature higher than the permitted value; • See E1.1 .	Change the position of the unit or the position of any adjacent obstructions to avoid recirculation. Press the reset button on the cap of the pressure switch.
	E4 See A4 .	E4.1 See E1.1 .	Clean the condenser fins. Press the reset button on the cap of the pressure switch.
	E5 See A5 .	E5.1 See E1.1 .	Remove obstruction from condenser intake. Press the reset button on the cap of the pressure switch.
	E6 See A1 .	E6.1 • Water outlet temperature too high; • refrigerant compressor stops.	Restore the thermal load to within the preset limits. Press the reset button on the cap of the pressure switch.

Table 8 TROUBLE SHOOTING



PROBLEM	CAUSE	SYMPTOM	REMEDY
F Compressor protection tripped (hermetic compressors klixon).	F1 Thermal load too high in concomitance with high ambient temperature.	F1.1 <ul style="list-style-type: none"> The head and body of the compressor are very hot; the compressor stops and attempts to start after a brief period. 	Stop the machine and restore the load within the preset limits. Wait a few minutes before restarting.
	F2 Thermal load too high in concomitance with a lack of refrigerant in the circuit (also see A5).	F2.1 See F1.1 .	Get a technician to check for leaks and eliminate them. Get the engineer to fill the circuit.
	F3 See points from E1 to E6 .	F3.1 See F1.1 .	See points from E1 to E6 .
G Fuse FC1 trips.	G1 Compressor motor overloading or short circuit, or short circuiting in the compressor power line.	G1.1 The compressor does not start even if the thermostat function so requires.	Using a tester, check the motor windings and the power cable. Replace the compressor or cable if necessary. Change the fuse.
H Fuse FF1 trips.	H1 Fan, pumps and electronic power overload or short circuit in the power line.	H1.1 The fan and electronic board do not work at the same time even if there is electric power.	Check the components and wiring with a tester. Replace the damaged component or wiring. Change the fuse.
I The compressor does not start (signalled by compressor LED flashing)	J Compressor delay on	K The compressor does not start	Verify parameters OdS, AC.
L The temperature is over the set limit but there is no alarm message and the buzzer, if present, does not sound	L1 Alarm delay on	L1.1 The temperature measured by the probe is higher than the set limit	Verify parameters ALd, dAO.
M Low temperature alarm	M1 The alarm delay is too short or the alarm threshold too low	M1.1 "LA" low temperature alarm displayed (See 7.6 "Storage temperature alarm")	Verify parameters ALL.
N High temperature alarm	N1 The alarm delay is too short or the alarm threshold too low	N1.1 "HA" high temperature alarm displayed (See 7.6 "Storage temperature alarm")	Verify parameters ALU.
O After modifying a parameter the electronic control continues to operate with the old values	O1 The instrument has not updated the old value or the parameter programming procedure was not concluded correctly, that is by pressing	O1.1 After modifying a parameter the electronic control continues to operate with the old values	Turn the instrument off and on again or re-program the parameters correctly

Table 8 TROUBLE SHOOTING

