

UNICO

USER'S MANUAL

Operation Manual & Instruction

SCISSOR LIFT

(MODEL: GC-3.0SL)

SMALL SCISSOR LIFT

GC-3.0SL

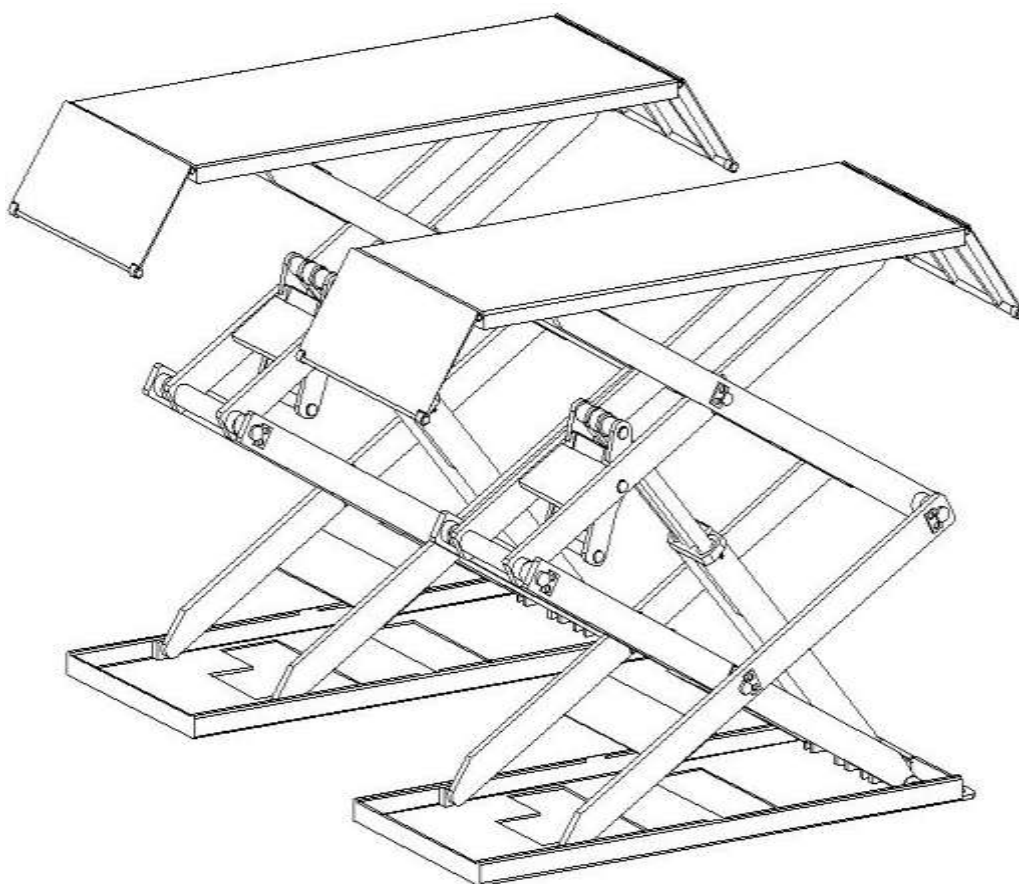

MANUFACTURER: Guangzhou Gaochang Hydraulic Technology Co. Ltd.
ADDRESS: Huangqishan Road, Yonghe Zone,
Guangzhou Economic & Technologic Development District,
511356 P.R.China

CONTENTS

Packing, transport and storage.....	4
Introduction.....	6
Chapter 1 Description of the machine.....	7
Chapter 2 Specifications.....	8
Chapter 3 Safeties.....	12
Chapter 4 Installation.....	17
Chapter 5 Adjustments.....	20
Chapter 6 Operations.....	23
Chapter 7 Maintenance and care.....	25
Chapter 8 Failures and resolutions.....	26
Chapter 9 Accessory	27

PACKING, TRANSPORT AND STORAGE**PACKING, TRANSPORT AND STORAGE**

ALL PACKING, LIFTING, HANDLING, TRANSPORT AND UNPACKING OPERATIONS ARE TO BE PERFORMED EXCLUSIVELY BY EXPERT PERSONNEL

PACKING (Picture 1)**Standard equipment**

oil line and accessory (1# CTN), main and sub beam (2# CTN), control box (3# CTN), front board (4# CTN), cover board (5#) total is 5 pieces.

Packing List

N0:	Name	Accessory name	Quantity
1	Oil and accessory	M16 ground bolt	12sets
		$\phi 6 \times \phi 4 \times 1000$ mm air pipe	1set
		$\phi 6 \times \phi 4 \times 2200$ mm air pipe	1set
		$\phi 6 \times \phi 4 \times 5400$ mm air pipe	1set
		$\phi 8 \times \phi 5 \times 3000$ mm air pipe	1set
		Three-way air pipe fitting	2ps
		1.5mm ² multicore wire 5m	1set
		$\phi 14$ combined cushions	4ps
		Tie-strip	15ps
		$\phi 6$ knee-way air pipe fitting	1ps
		High pressure pipe 860mm	6ps
		High pressure pipe 5400mm	3ps
		M8 ground bolt	32sets
		Maintenance and use manual	1ps
		Exchange fitting	1ps
		Rubber cushion 80×120×180	4ps
2	Lift beam	Both main beam and sub beam	2ps
3	Control box		1ps
4	Sliding board	Sliding board	4ps
		Pin	4sets
5	Back stop board	720mm	1ps
		750mm	2ps
		1000mm	2ps
		635mm	2ps
		250mm directly knee	1ps

Table 1

PACKING, TRANSPORT AND STORAGE

Packing dimension picture

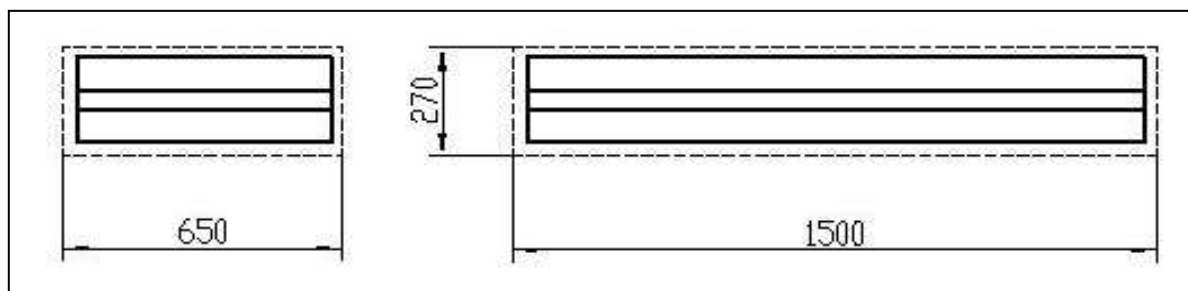

Picture 1

Transport (Picture 2)



Packing can be lifted or moved by lift trucks, cranes or bridge cranes. In case of slinging, a second person must always take care of the load, in order to avoid dangerous oscillations.

During loading and unloading operation, goods must be handled by vehicles or ships.

At the arrival of the goods, verify that all items specified in the delivery notes are included. In case of missing parts possible defects or damage due to transport operations.

If finding missing parts, possible defects or damage due to transport, one should examine damaged cartons according to <<Packing List.>> to verify the condition of damaged goods and missing parts, also the person in charge or the carrier must be immediately informed.

The machine is heavy goods! Don't take manpower load and unload and transporting way into consideration, the safety of working is important.

Furthermore, during loading and unloading operation goods must be handled as shown in the picture. (Picture 2)

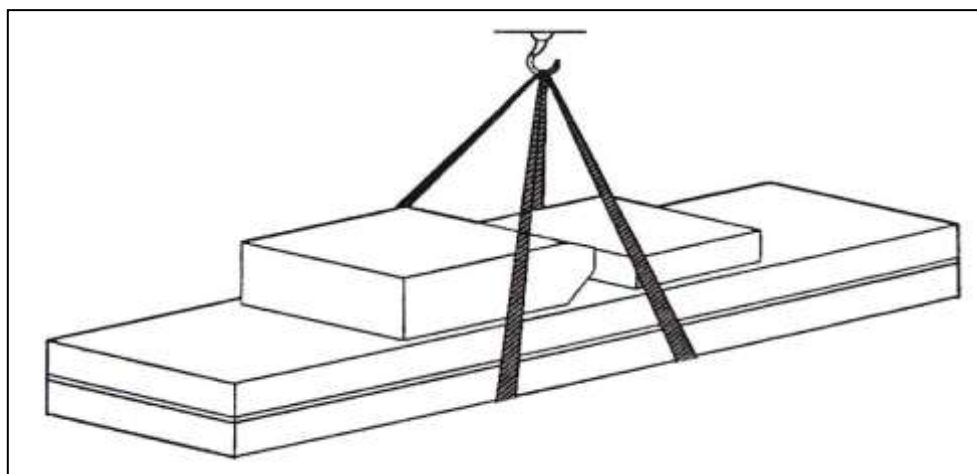

Picture 2

Storage:

-The machine equipment should be stocked in the warehouse, if stocked outside should do the disposal well of waterproof.

-Use box truck in the process of transport, use container storage when shipping.

-The control box should be placed perpendicularly during the transport; and prevent other goods from extrusion.

-The temperature for machine storage: -25 °C-- 55 °C

INSTRUCTION

This manual has been prepared for workshop personnel expert in the use of the lift operator and technicians responsible for routine maintenance fitter.

Workers should read the <<Maintenance & Use Manual>> carefully before carrying out any operation with the lift. This manual contains important information regarding:

- The personal safety of operators and maintenance workers.
- Lift safety,
- The safety of lifted vehicles

**CONSERVING THE MANUAL**

This manual is an integral part of the lift.

The manual must be kept in the vicinity of the lift, so that the operator and maintenance staff must be able to locate and consult the manual quickly and at any time.

Attentively reading Chapter 3, which contains important information and safety warning, is particularly recommended.

The lift is designed and manufactured according to European Standard

The lifting, transport, unpacking, assembly, installation, starting up, initial adjustment and testing, extraordinary maintenance, repair, overhauls, transport and dismantling of the lift must be performed by specialized personnel from the licensed dealer authorized by the manufacturer.

The manufacturer declines all responsibility for injury to persons or damage to vehicles or objects when any of the above mentioned operations has been performed by unauthorized personnel or when the rack has been subject to improper use.



This manual indicates: the operative and safety aspects that may prove useful to the operator and maintenance worker. For better understanding the structure and operation of the lift and for best use of the same, workers must read the <<Maintenance & Use Manual>> carefully before carrying out it.

In order to understand the terminology used in this manual, the maintenance and repair activities, the ability to interpret correctly the drawings and descriptions contained in the manual and be the country in which the machine has been installed.

The same applies to the maintenance and the maintenance fitter must also possess specific and specialized knowledge both in mechanical and engineering field.

- OPERATOR: person authorized to use the lift
- MAINTENANCE FITTER: person authorized for routine maintenance of the lift.



Manufacturer owns the right to make little change for the manual owing to the improvement of technology.

Chapter 1 DESCRIPTION OF THE MACHINE

Machine Application:

Small platform profile scissor lift can lift each kind of vehicle whose weight is less than 3000kg, suitable for use in vehicle tests, maintenance and caring for automobiles, which is particularly suitable for use in the basement or on the floor, without construction and hole.

Structure Features:

- use hidden and thin scissor structure, dispense with construction and ground hole, the occupation is small
- independent control box, low-voltage controlling, good security
- hydraulic cubage and in-phase cylinder, the synchronization of platform
- own the double safety equipment of hydraulic lock and mechanical pawl, on the safe side
- Own protection of safety valve and burst-proof equipment for hydraulic failure and over loading. So when the oil pipe bursts, the machine will not fall quickly.
- use high quality hydraulic or electric element parts made in Italy, Germany, Japan and so on.
- Own manual lowering operation when the power is cut.

Equipment:

- machine basement (The position and space of equipment installation)
- machine frame (The main structure of lift and insurance institution)
- Control box (Machine-controlled part)

Basic structure

The machine basement is made of cement and concrete

Frame

Make of steel connecting rod, main lifting platform, sliding board, pneumatic double tooth ,hydraulic oil tank.

Control box

Under the control box is hydraulic oil tank and hydraulic pump, valve and other control system. On the control box is electrical system.



Scissor lift is designed and built to lift all kinds of vehicles, all other use are unauthorized. In particular, the lift is not suitable for washing spray work. And not lift the vehicle whose weight exceeds the maximum weight.

Chapter 2 SPECIFICATIONS

Main technical parameter

Machine type	3.0T
Drive	Electrical hydraulic
Max lift weight	3000kg
Main machine lift height	1830mm
Platform initial height	105mm
Platform length	1450mm
Platform width	635mm
Lifting time	≤50s
Descent time	≤60s
Whole machine length	2040mm
Whole machine width	1990 mm
Weight	850kg
Power supply	AC 400V or 230V ±5% 50Hz
Whole machine power	2.2kw
Hydraulic oil	12L corresponds to wearable hydraulic oil
Air pressure	6-8kg/cm ²
Working temperature	5-40℃
Working humidity	30-95%
Noisy level	< 76db
Installation height	height above sea level ≤1000M
Storage temperature	-25℃ ~55℃

Table 2

INSTALLATION SCHEME FOR SCISSOR LIFT

Supply at the same time

- connect to the power supply jack of control box (400V or 230V 15A)
- connect to the compressed air-entering pipe of control box ($\phi 8 \times 6\text{mm}$)

Requirements:

Concrete type 425#, the period of desiccation is 15 days
 clean the basic layer, thickness of concrete $\geq 150\text{mm}$, the leveling of whole length $\leq 10\text{mm}$

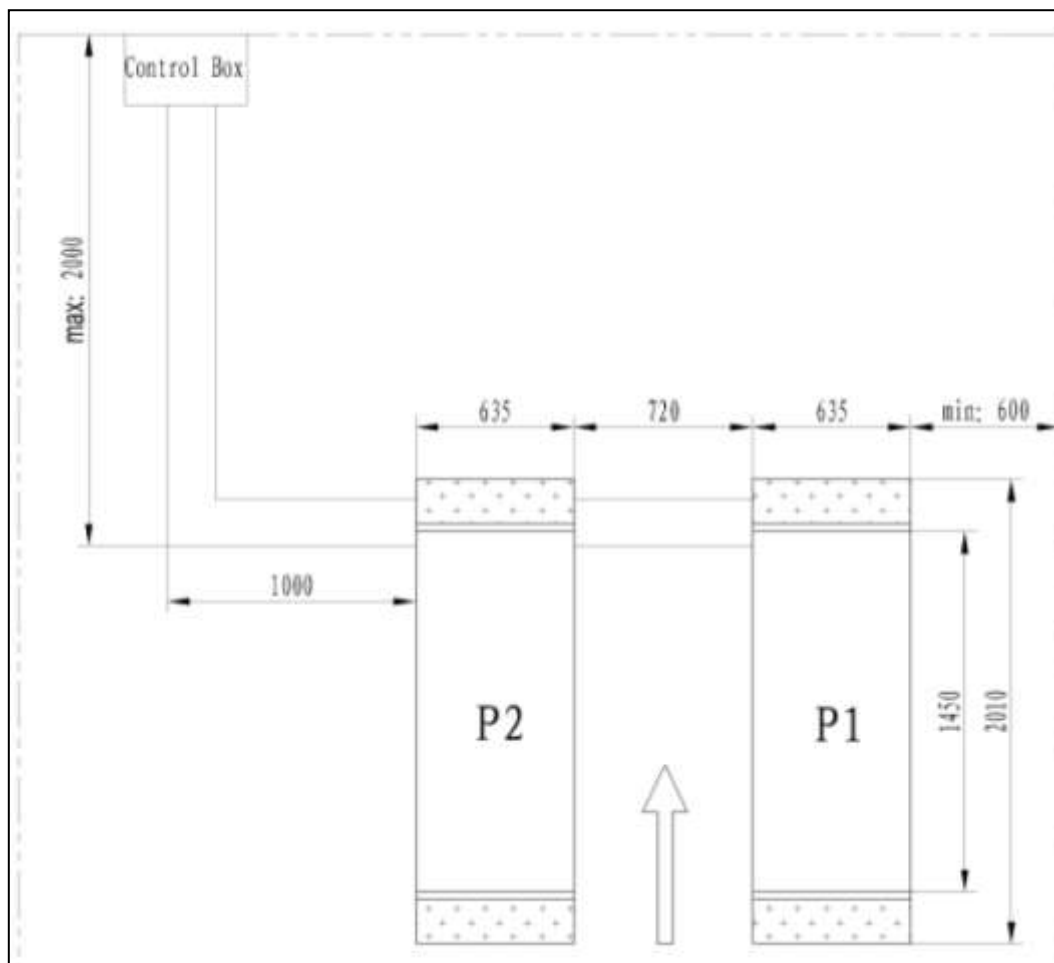

Picture 4(Equipment basic picture)
 The control box can be placed on the left or right



Note: The foundation of the end of the lift platform P1, P2 is the structure of concrete. When the thickness of inside level ground is less than 150mm, the end of P1, P2 should be irrigated the acreage: 2500x2500mm and thickness of concrete $\geq 150\text{mm}$
 The basic thickness of concrete and leveling are keys, shouldn't egregiously expect the ability of level adjustment of machine-self.

TYPES OF VEHICLES SUITABLE FOR:

This lift are suitable for virtually all vehicles with total weight and with dimensions not exceeding the below data.

MAXIMUM WEIGHT

Maximum weight not exceed than 3000Kg

THE MAX DIMENSION OF VEHICLE: The following diagrams illustrate criteria used to define the operating limits of the lift.

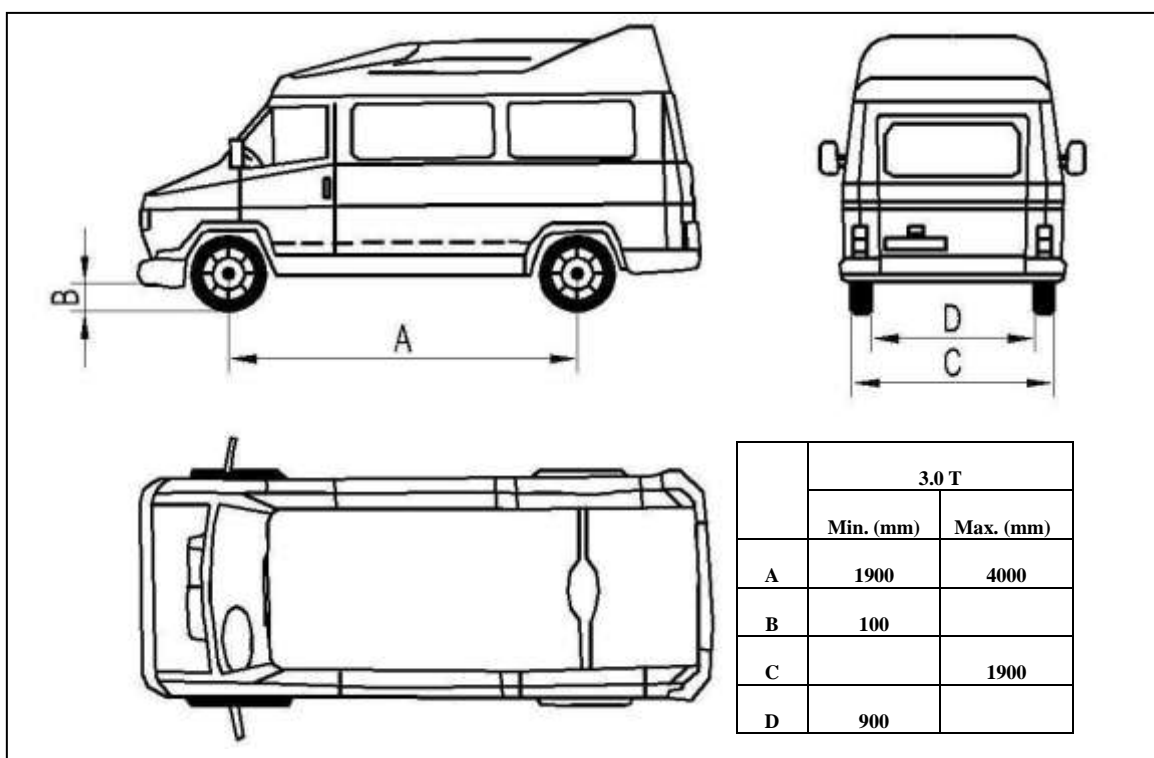

Picture 5

 THE LOWER PARTS OF THE VEHICLE UNDERBODY COULD INTERFERE WITH STRUCTURAL PARTS OF THE LIFT, TAKE PARTICULAR PARTS OF THE SPORTS-CAR.

The lift will also handle customized or non-standard vehicles provided they are within the maximum specified carrying capacity.

Also the personnel safety zone must be defined in relation to vehicle with unusual dimensions.

Chapter 3 SAFETIES



Read this chapter carefully and completely since important information for the safety of the operator or others in case of improper use of the lift is included.

In the following text there are clear explanations regarding certain situations of risk or danger that may arise during the operation or maintenance of the lift, the safety device installed and the correct use of such systems, residual risks and operative procedures to use (general specific precautions to eliminate potential hazards).



Lifts are designed and built to lift vehicles and hold them in the elevated position in an enclosed workshop. All other uses of the lifts are unauthorized. In particular, the lifts are not suitable for:

- washing spray work;
- creating raised platforms for personnel or lifting personnel;
- use as a press for crushing purposes;
- use as elevator;
- use as a lift jack for lifting vehicle bodies or changing wheels.



The manufacturer is not liable for any injury to persons or damage to vehicles and other property caused by the incorrect and unauthorized use of the lifts.

During lifting and descent, the operator must remain in the control station as the diagrams illustrated. As the diagrams illustrated: the presence of persons inside the danger zone indicated is strictly prohibited. During operations persons are admitted to the area beneath the vehicle only when the vehicle is already in the elevated position, when the platforms are stationary, and when the mechanical safety devices are firmly engaged (eg : the safety gear is completely locked).



DO NOT USE THE LIFT WITHOUT PROTECTION DEVICES OR WITH THE PROTECTION DEVICES INHIBITED.

FAILURE TO COMPLY WITH THESE REGULATION CAN CAUSE SERIOUS INJURY TO PERSONS, AND IRREPEARABLE DAMAGE TO THE LIFT AND THE VEHICLE BEIN LIFED.

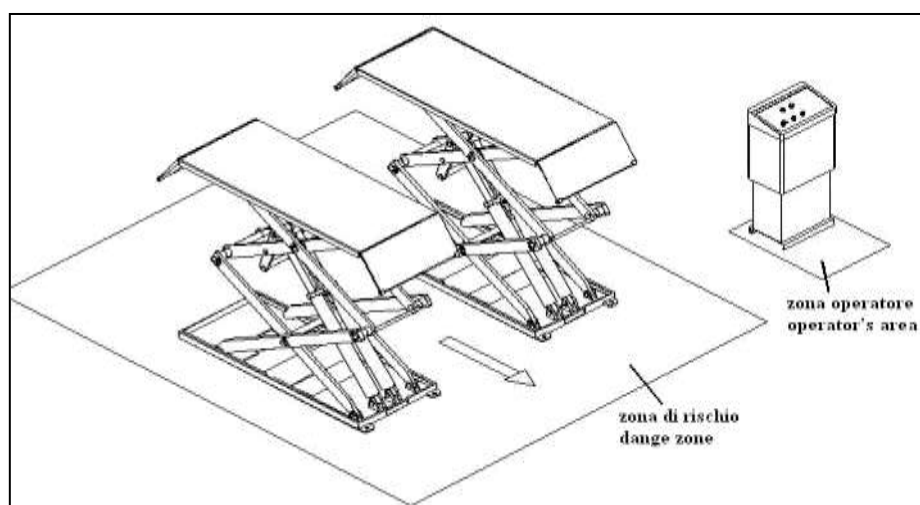

Picture 6

GENERAL PRECAUTIONS



The operator and the maintenance fitter are required to observe the prescriptions of safety regulation in force in the country of installation of the lift.

Furthermore, the operator and maintenance fitter must:

- always work in the stations specified and illustrated in this manual;
- never remove or deactivate the guards and mechanical, electrical, or other types of safety devices;
- read the safety notices placed on the machine and the safety information in this manual.



In the manual all safety notices are shown as follows:

WARNING: indicates following operations that are unsafe and can cause minor injury to persons and damage the lift, the vehicle or other property.



CAUTION: indicates possible danger that can result in serious injury to people and damage property.



RISK OF ELECTRIC SHOCK: a specific safety notice placed on the lift in areas where the risk of electric shock is particularly high.

RISK AND PROTECTION DEVICES

We shall now examine the risks that operators or maintenance fitters may be exposed to when the vehicle is standing on the platforms in the raised position, together with the various safety and protection devices adopted by the manufacturer to reduce all such hazards to the minimum:

For optimal personal safety and safety of vehicles, observe the following regulations:

- do not enter the safety and safety of vehicles are being lifted. (Picture 6)
- make sure the vehicle is positioned correctly. (Picture 7)
- be sure to lift only approved vehicles, never exceed the specified carrying capacity, maximum height, and projection (vehicle length and width);
- make sure that there is no person on the platforms during up and down movements and during standing.

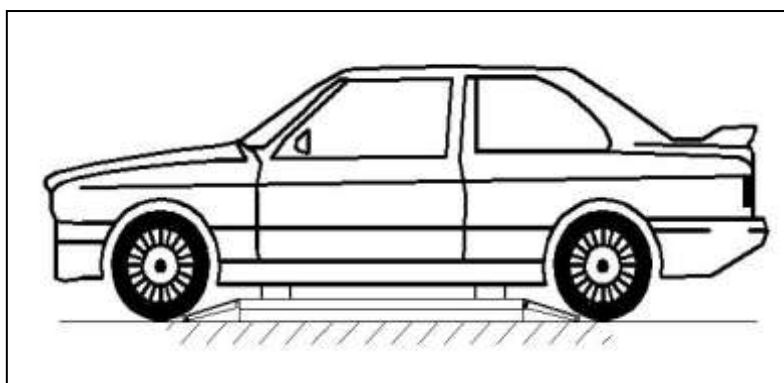

Picture 7

GENERAL RISKS FOR LIFTING OR DESCENT:

The following safety equipments are used to protect over loading or the possibility of engine failure.

In the condition of over loading, the over-falling valve will open and directly return oil to the oil tank. (See Picture 8)

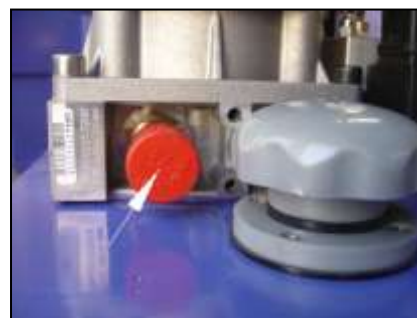

Picture 8

Each bottom of oil cylinder is equipped with antiknock and locked valve. When the oil pipe is burst in the circuit of hydraulic pressure, the relevant antiknock and locked valve will work and limit the speediness of platform. (See Picture 9)

Safety tooth and gear module are parts which guarantee the safety of personnel beneath the machine in failure condition of other protections. So make sure the integrity of gear module and that the safety tooth has occluded completely. (Picture 10)



Picture 9



Picture 10



There is nothing abnormal should be left on the safety modules to prevent safety gear from occlude normally.



RISKS FOR PERSONNEL

This heading illustrates potential risks for the operator, maintenance fitter, or any other person present in the area around the lift, result from incorrect use of the lift.



RISKS FOR EXTRUSION

During up and down operations, personnel leave the said area without following the rule and instruction.

During up and down operations, no person is admitted to work beneath the movable parts of the lift, should work in the safe zone. (Picture 6)



RISK OF IMPACT (Picture 11)

Before the operator begins up and down movements, make sure that there are no personnel inside the danger zone. When, due to operational reasons, the lift is stopped at relatively low elevations (lower than 1.75m above the ground) personnel must be careful to avoid impact

with parts of the machine not marked with special colors.



RISK OF FALLING OFF (PERSONNEL)

During up and down operations, personnel are prohibited from entering the platforms and the vehicle to avoid falling off.



RISK OF FALLING (VEHICLE)

This hazard may arise in the case of incorrect positioning of the vehicle on the platforms, overweight of the vehicle, or in the case of vehicles of dimensions that are not compatible with the capacity of the lift.



When the platform is being tested, the vehicle engine can not be turned on. There is nothing should be placed on the lift-lowering area and the movable parts of the lift.



RISK OF SLIPPINE (Picture 12)

The floor caused by lubricant contamination of around the lift. The area beneath and immediately surrounding the lift and also the platforms must be kept clean. Remove any oil spills immediately.

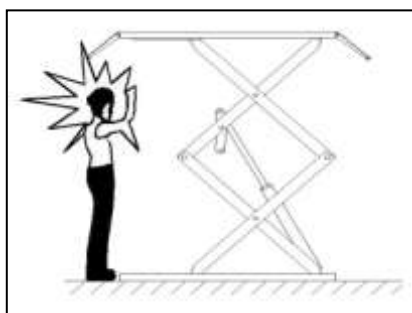

Picture 11

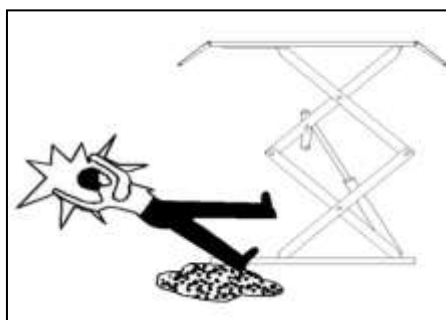

Picture 12



RISK OF ELECTRIC SHOCK

Risk of electric shock in areas of insulated and shattered electric equipments.

Do not use jets of water, steam solvents or paint next to the lift, and take special care to keep such substances clear of the electrical control panel.



RISKS RELATED TO IMAPPROPRIATE LIGHTING

The operator and the maintenance fitter must be able to assure that all the areas of the lift are properly and uniformly illuminate compliance with the laws in force in the place of installation.

During up and down operations, the operator should continually observe the lift and can operate it only in the position of operator. When lifting and lowering the vehicle, the cushion needs being put in the bottom of chassis.



The handling of safety devices is strictly forbidden. Never exceed the maximum carrying capacity of the lift, make sure the vehicles to be lifted have no load.



It is therefore essential to adhere scrupulously to all regulations regarding use, maintenance and safety contained in this manual.

Chapter 4 INSTALLAION



SKILLED AND AUTHORIZED PERSONNEL ONLY SHOULD BE ALLOWED TO PERFORM THESE OPERATIONS, FOLLOW ALL INSTRUCTIONS SHOWN BELOW CAREFULLY, IN ORDER TO PREVENT POSSIBLE DAMAGE TO THE CAR LIFT OR RISK OF INJURY TO PEOPLE.

Skilled technicians only appointed by the same manufacturer or by authorized dealers, are allowed to install the car lift.

INSTALLATION REQUIREMENTS

- The car lift must be installed according to the specified safety distances from walls, pole and what other equipments stated. (Picture 13)
- The specified safety distances from walls must be 1000 mm at least, taking into consideration the necessary space to work easily. Because space for the control site and for possible runways in case of emergency is also necessary.
- The room must be previously arranged for the power supply and pneumatic feed of the car lift.
- The room must be 4000 mm in height, at least.
- The car lift can be placed on any floor, as long as it is perfectly level and sufficiently resistant. ($\geq 250\text{kg}/\text{cm}^2$, the thickness of concrete $\geq 150\text{mm}$)

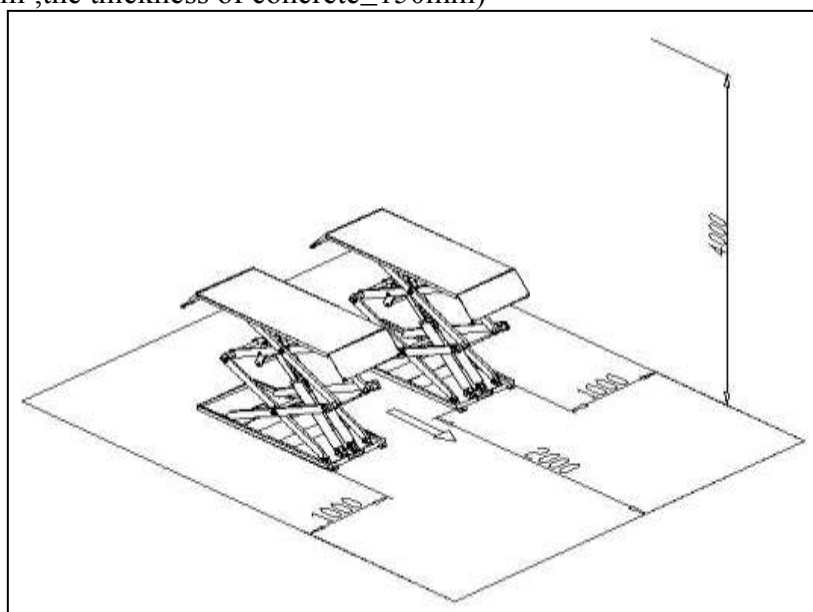

Picture 13

- All parts of the machine must be uniformly lit with sufficient light to make sure that the adjustment and maintenance operations can be performed safely, and without reflected light, glare that could give rise to eye fatigue.
- The integrality of arrived goods should be checked before the lift is installed.
- Moving and installing lift should follow the process as the picture instructs.

The transport and storage of machine refers to “TRANSPORT AND STORAGE” on page **.

Chapter 4 INSTALLAION

Platform Installation:

- Place two lift platforms on the position of the location
- The bottom of oil cylinder is located in the frontage of machine (the direction of getting on the vehicle)
- Use fork car or other lifting equipments to lift the platform (Picture14) and make sure that the safety equipment of machine is both turned on and locked.

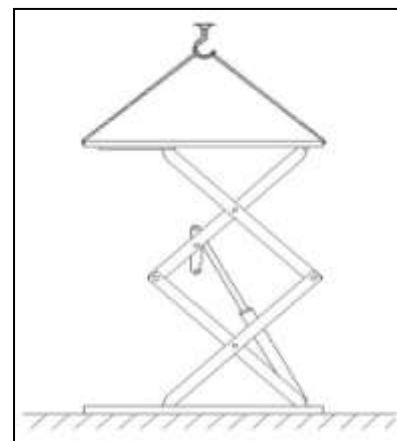

Picture 14



To avoid failure of machine safety equipment, can insert a wood in the middle part of joint-pole.

Prohibit working beneath the lift when hydraulic system is not completely equipped with hydraulic oil and take the action of up and down operations.

- When moving the lift platform, adjust the space between two platforms, make sure that the two platforms are parallel.

LINE CONNECTION

Connect the electrical and oil line according to <<the electric wiring diagram>> and <<oil line connection>>.



Only after connecting the hydraulic system can connect the air loop, can not damage oil pipe, wire, and air pipe.

In the process of connecting oil pipe and air pipe, pay particularly attention to the protection of pipe tie-in to prevent abnormal thing from entering oil loop and air loop, then damaging hydraulic system.

ELECRIC CIRCUIT CONNECTION:

Follow the stated line- pathway and line-number of <<the electric wiring diagram>> to connect electric circuit.



Only skilled person is allowed to perform the operations.

- open the control box front cover

-connection of power supply: the 400V three-phase and five-line connection wires ($3 \times 2.5\text{mm}^2 + 2 \times 1.5\text{mm}^2$ cable wire) for power supply are connected to control box L1,L2,L3,N and entering-wire terminal. The PE ground wire is connected under the bolt marked ground firstly (Picture 15) and then connected under the bolt marked ground of two platforms.

- If the lift is operated at 230V three-phase, change the connection on the transformer and motor. (Picture 16)

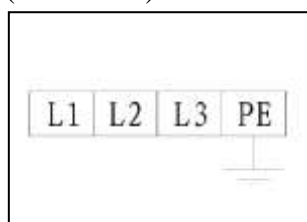

Picture 15

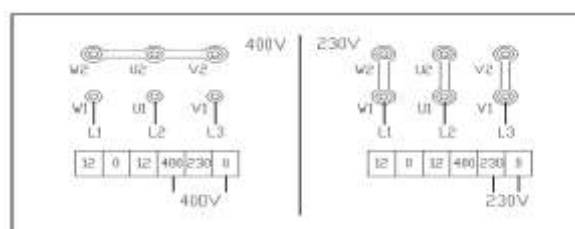

Picture 16

HYDRAULIC PIPELINE CONNECTION:

Follow <<oil line diagram >> to connect the hydraulic oil pipes



Only skilled and authorized person is allowed to perform the operations. And pay particularly attention to the protection of vita head.

-Following vita number to lead the high-pressure vita out from the “working stop valve G” and two “oil make-up stop valve H, I” of control box and then connect it to oil cylinder. (Refer to <<oil line diagram>>)

-when connecting vita, pay attention to the protection of vita tie-in to prevent impurities from entering hydraulic circuit.



When connecting the vita, be care of the mistake of each vita number.

During the standard installation, control box is in the nearside of vehicle-entering direction. If placed on the right should adjust relevant vita.

COMPRESSED AIR PIPE CONNEVTION:

Follow <<air loop diagram >> to connect air loop



Only skilled and authorized person is allowed to perform the operations.

-Connect $\Phi 8 \times 6$ compressed air supply pipe to the air supply jaws of pneumatic electromagnetic valve inside the control box. (Picture17)

-Follow <<air loop diagram >> to lead the compressed air pipe out from pneumatic electromagnetic valve and then connect it to the uplifted-pawl air valve. (Picture 18)

-Pay attention to the protection of windpipe tie-in to prevent impurities from entering compressed air circuit.

-Connect compressed air pipe to the extra-installed grease separator which is in front of control box to prolong the life of pneumatic components and the reliability of action.



In the process of windpipe installation, the windpipe can not be folded or tied to avoid that the air loop is not smooth or it is jammed.

Before leading the compressed air supply pipe to the air supply jaws of pneumatic electromagnetic valve inside the control box, should extra install grease separator to separate compressed air, avoiding the failure of pneumatic cell action.



Picture 17



Picture 18

Chapter 5 ADJUSTMENTS



Add oil and check the order of phase.

After installing lift as Picture 4 required and connecting hydraulic circuit, electric circuit and air loop, operate it as following:

-open the hydraulic oil tank, add 18L of hydraulic oil into the oil tank, the hydraulic oil is provided by the user.



Make sure the clean of hydraulic oil, prevent any impurity into the oil line, lead the digest of the oil line and no working of the solenoid valve.

-press the “power” button to turn on power, clicking the “up” button, check whether the motor turns clockwise (looking downward), if not press “power” button, change the phase of the motor.

-turn on air power

When turn on power, the high voltage will exist in the control box, only authorized person can operate it.

Oil make-up adjustment

1. Open the stop valve ‘G’ and valve ‘H’ ‘I’
2. Press “UP” button SB1; let the platform going up to the height place.
3. Switch off the valves ‘H’ and ‘I’, press ‘DOWN’ button SB2; the platform going down to the ground.
4. Repeat the operation as above for 3~4 times.
5. Press ‘UP’ button SB1, let the platform going up to about 500mm height. If the two platform not at the same level, switch off ‘the work stop valve G’. The left platform is little lower (P1), turn on ‘the oil make-up valve I’, otherwise, turn on ‘the oil make-up valve H’
6. Click the button SB1, and then the single side of platform is lifted alone. After the two platforms both have the same height, close the oil make-up stop valve “H” or “I”, turn on “the work stop valve”, the oil adjustment process comes to the end.
7. Turn right opening the “PHOTO” button to let the photocell working to protect the lift only to be operated at the same level.

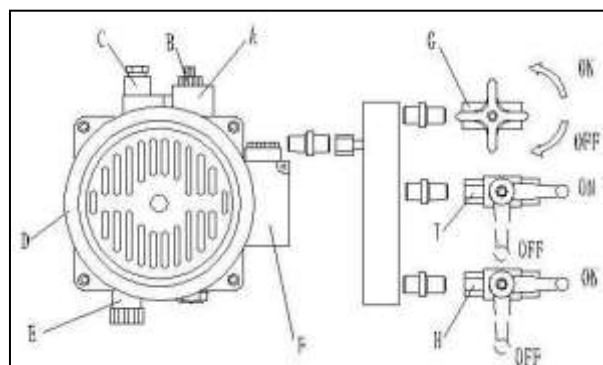

Picture 19

Check: whether the locations of two safety-pawl equipments are agile and reliable, oil leakage of the oil line and air tightness of the air loop.

GROUND BOLTS INSTALLATION:



The ground bolts installation must start after the expiry date on the maintenance of concert, otherwise, it will affect the quality of solidity.

-adjust the parallel of the platform and the distance of two platform as Picture 4 requires.

- fix the anchor bolts with a percussion electric drill (percussion drill bit is of 16), drill to

120mm hole and clean the hole.(picture 20)

-use light hammer to install the ground bolts into the hole (need not install the central expanded nail of ground bolts, install it after level adjustment.)



Picture 20

Level adjustment:

- By using a level bar and the horizontal pipe and adjusting the adjustment screws at tow sides of the base plate.
- If platform unevenness is resulted from basic unevenness, use iron block to fill up the low place.
- After level adjustment, insert the central expanded nail of ground bolts and use heavy hammer to hammer it.
- Screw down the ground bolts cap

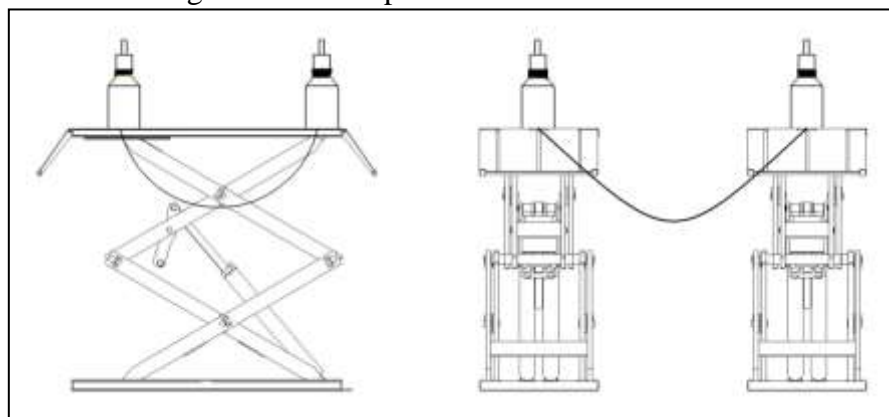

Picture 21



When the expiry date on the maintenance of concrete hasn't arrived, can not install the central expanded nail of ground bolts.

the gap between the base plate and ground after adjustment must be filled with iron plate or concrete.

No load of main machine test:

- turn on the power QS.
- press "up" button SB1, pay attention to the synchronization and placidity of the lifting.
- check whether safety pawl is correctly located.
- check whether the oil line and the air line are leakage.



When testing the lift, no person or other things are allowed to stand or be put near the two

sides and beneath the machine. If any abnormal is found, press button “SB0” to stop it timely. After clearing obstacles, do the test again.

Load of machine test:

- Drive the vehicle whose weight doesn't exceed maximum lift weight to the platform, and then the driver leave it.
- Put the lift rubber cushion on the nuchal-seat.
- press “up” button SB1, lift the platform and pay attention to the synchronization and placidity of the lifting.
- check whether safety pawl is correctly located.
- check whether the oil line and the air line are leakage.



When beginning load of machine test, no person or other things are allowed to stand or be put near the two sides and beneath the machine.

Test vehicle whose weight doesn't exceed maximum lift weight.

Check whether the oil line and the air line are leakage. If any abnormal is found, press button “SB0” to stop it timely. After clearing obstacles, do the test again.

Chapter 6 OPERATIONS



Only skilled and having been trained personnel is allowed to perform the operations. Check proceedings as following.

Operation Notices:

- clear obstacles around the lift before operation.
- during lifting or lowering, no person is allowed to stand neat the two sides and beneath the machine, and no person is allowed on the two platform.
- avoid lifting super heavy vehicles or other goods.
- when lifting vehicle, the chassis of the vehicle should be filled up with rubber cushion.
- pay attention to the synchronization of the lifting and lowering. If any abnormal is found, stop the machine timely, check and remove the trouble.
- when lowering vehicle, lift the platform a bit firstly, notice that whether two safety pawls and safety teeth have been disengaged completely. If not, stop lowering.
- when the equipment is not used for a long time or over night, the machine should be lowered to the lowest position on ground, and remove vehicle, and cut off power supply.

Instructions on electric operation: (see the operation panel)



Picture 22

LIFTING:

- press “lift” button SB1, the oil pump will work immediately, hydraulic oil is sent to hydraulic cylinder through “the work stop valve”, the platform is being lifted and the safety pawl is also lifted because of air loop.
- release button SB1, the oil pump will stop immediately, the platform stops lifting and the safety pawl falls on the safety gear because electromagnetic air-valve is out of electricity and then close the air loop.

DESCENT:

- press “DOWN” button SB2, the safety pawl will be lifted by joint air loop and lowering-
- electromagnetic valve opens because of electricity. The platform is lowing, release button SB2, stop lowering, the safety pawl falls on the safety gear.

EMERGENCY STOP:

When the machine has abnormal or car maintenance, push “emergency stop” button “SB0” and locking, cut off all the operation circuit, other operation can not be work.

NOT IN-PHASE STOP MACHINE:

When two platforms are not at the same height during lifting and lowering operations, photo-electricity leveling equipment will stop working immediately. According to the following process to adjust the platform level, only after two platforms are at the same height can put them into use.

Oil make-up “adjust” operation (normal service period):



After completion of machine installation and adjustment in the application process, the right platform is lower than the left one because of air in the oil cylinder not being excluded completely normal looses or leakage of the hydraulic oil.



When conducting oil make-up operation, the platforms must not be load. Adjustment process as ‘Oil make-up adjustment’ approach ‘5’ and ‘6’.



EMERGENCY MANUAL OPERATION FOR LOWERING (POWER FAILURE):

When lowering through manual operation, should observe the condition of platform at any time because there are vehicles on the platform. If there is something abnormal, screw down oil loop valve immediately.

The process of manual operation:

- firstly lift two safety pawls of platform and use thin iron bar to fill up it.
- switch off the power button (avoid abruptly incoming electricity). Open the back cover of control box to find the electromagnetic valve A for lowering.
- loosen manual oil loop stud at the end of lowering electromagnetic valve core, then the platform begins lowering.
- after the machine has been lowered, screw down manual oil loop stud timely, the process of manual lowering comes to the end.

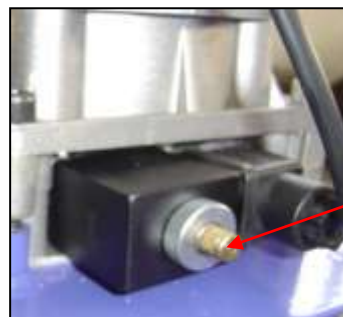

Picture 23

Chapter 7 MAINTENANCE AND CARE



Skilled personnel only is allowed to perform the operations.

- all bearings and hinges on this machine must be lubricated once a week by using an oiler.
- the safety gear, the upper and lower sliding blocks and other movable parts must be lubricated once a month.
- the hydraulic oil must be replaced one time each year. The oil level should always be kept at upper limit position.



The machine should be lower to the lowest position when replace hydraulic oil, then let the old oil out, and should be filter the hydraulic oil.

- Each team checks the agility and reliability of pneumatic safety equipment.

Chapter 8 FAILURE AND RESOLUTIONS



Skilled personnel only is allowed to perform the operations.

Failure Phenomena and Resolutions

Failure Phenomena	Cause and Phenomena	Resolutions
The motor does not run in lifting operation.	① Connection of power supply wires is not correct.	Check and correct wire connection
	② The AC contactor in the circuit of the motor does not pick up.	If the motor operates when forcing the contactor down with an isolation rod, check the control circuit. If the voltage at two ends of the contactor coil is normal, replace the contactor.
	The limit switch is not closed.	Check the limit switch, wires and adjust or replace the limit switch.
In lifting operation, the motor runs, but there is no lifting movement	① The motor turns reverse.	Change the phases of the power supply wires.
	② Lifting with light load is normal but no lifting with heavy load.	The set safe pressure of the over-flow valve may be increased by turning the set knob right ward slightly. The spool of the lowering solenoid valve is stuck by dirt. Clean the spool.
	③ The amount of hydraulic oil is not enough.	Add hydraulic oil.
	④ The “operation stop valve” is not closed.	Screw down the “Operation stop valve”.
When press “Lower” button, the machine is not lowered	① The safety pawl are not released form the safety teeth.	First lift a little and then lowering
	② The safety pawl is not lifted.	The air pressure is not enough, the safety pawl is stuck or the air pipe is broken off, adjust pressure, check the air pipe and replace it.
	③ The solenoid air valve does not work.	If the solenoid air valve is energized, but does not open the air loop, check or replace the solenoid air valve.
	④ The lowering solenoid valve is energized but does not work.	Check the plug and coil of the lowering solenoid valve and check the right turn tightness of its end copper nut and so on.
	⑤The “antiknock valve” is blocked.	Remove the “antiknock valve” from the oil supply hole at the bottom of the oil cylinder, and clean the “antiknock valve”.
The machine lowers extremely slowly under normal loads.	①The hydraulic oil has too high viscosity or frozen, deteriorated (in Winter).	Replace with hydraulic oil in accordance with the instruction book.
	② The “antiknock valve” for preventing oil pipe burst is blocked.	Remove or close air supply pipe and thus lock the safety pawl of the machine without lifting of the safety pawl. Remove the “antiknock valve” from the oil supply hole at the bottom of the oil cylinder, and clean the “antiknock valve”.
The right and left platforms are not synchronous and not in the same height.	① The air in the oil cylinder is not vent completely.	Refer to “VII. Oil Make-up ‘Adjust’ Operation”.
	② Oil leakage on oil pipe or at its connections.	Tighten oil pipe connections or replace oil seals and then make-up oil and adjust levelness.
	③ The “oil make-up stop valve” can not be closed tightly and almost make-up oil and adjust every day.	Replace oil make-up stop valve, and then make-up oil and adjust.
Noisy lifting and lowering.	①Lubrication is not enough.	Lubricate all hinges and motion parts (including piston rod) with machine oil
	② The base or the machine is twisted.	Adjust again the levelness of the machine, and fill or pad the base.

Table 3

Hydraulic pressure elements diagram

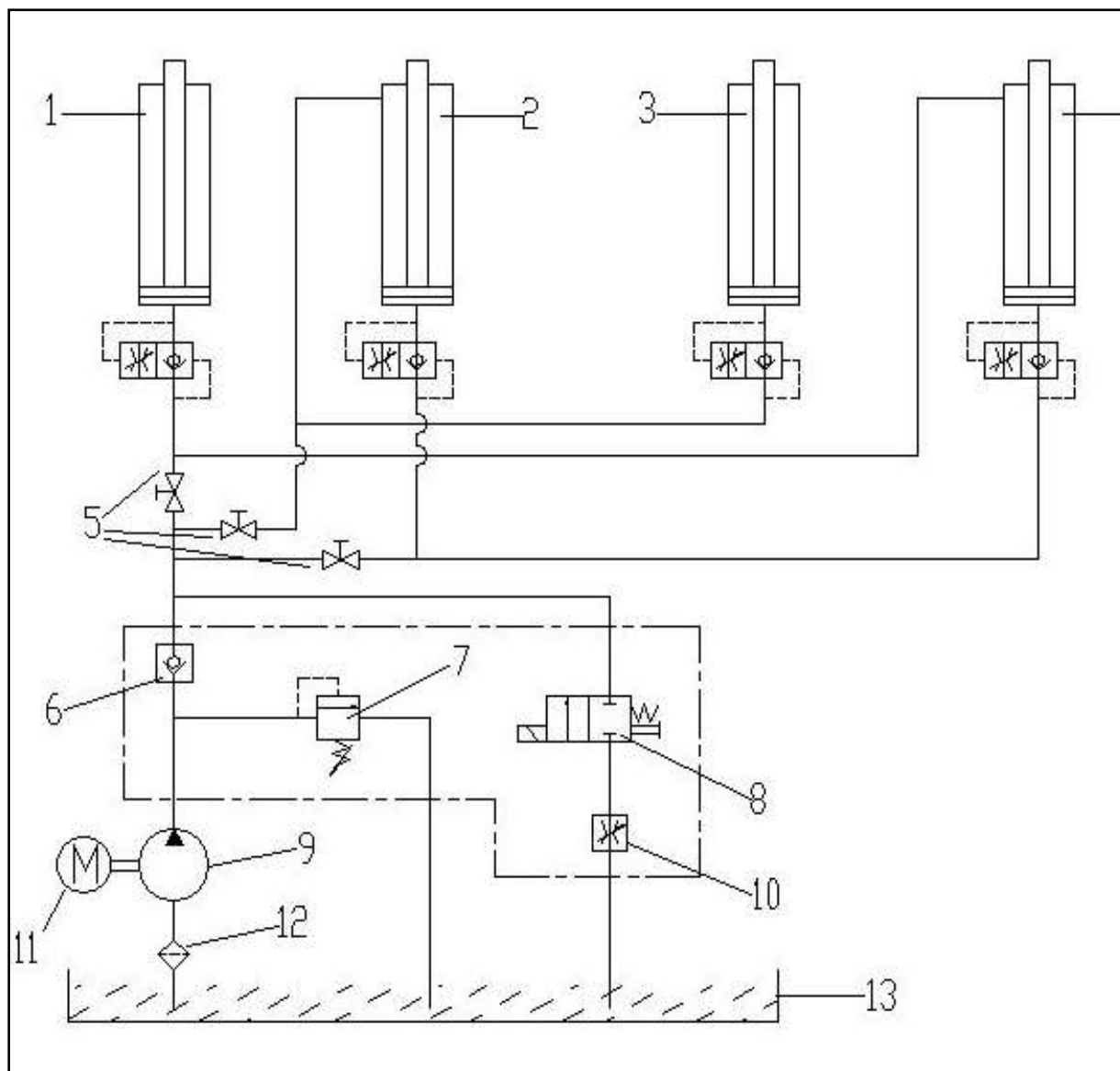

1.3. sub cylinder

9. gear pump

2.4. main cylinder

10. flow control valve

5. stop valve

11. pump motor

6. check valve

12. filter

7. overflowing valve

13. oil tank

8. descent valve

ACCESSORY

Hose connection diagram

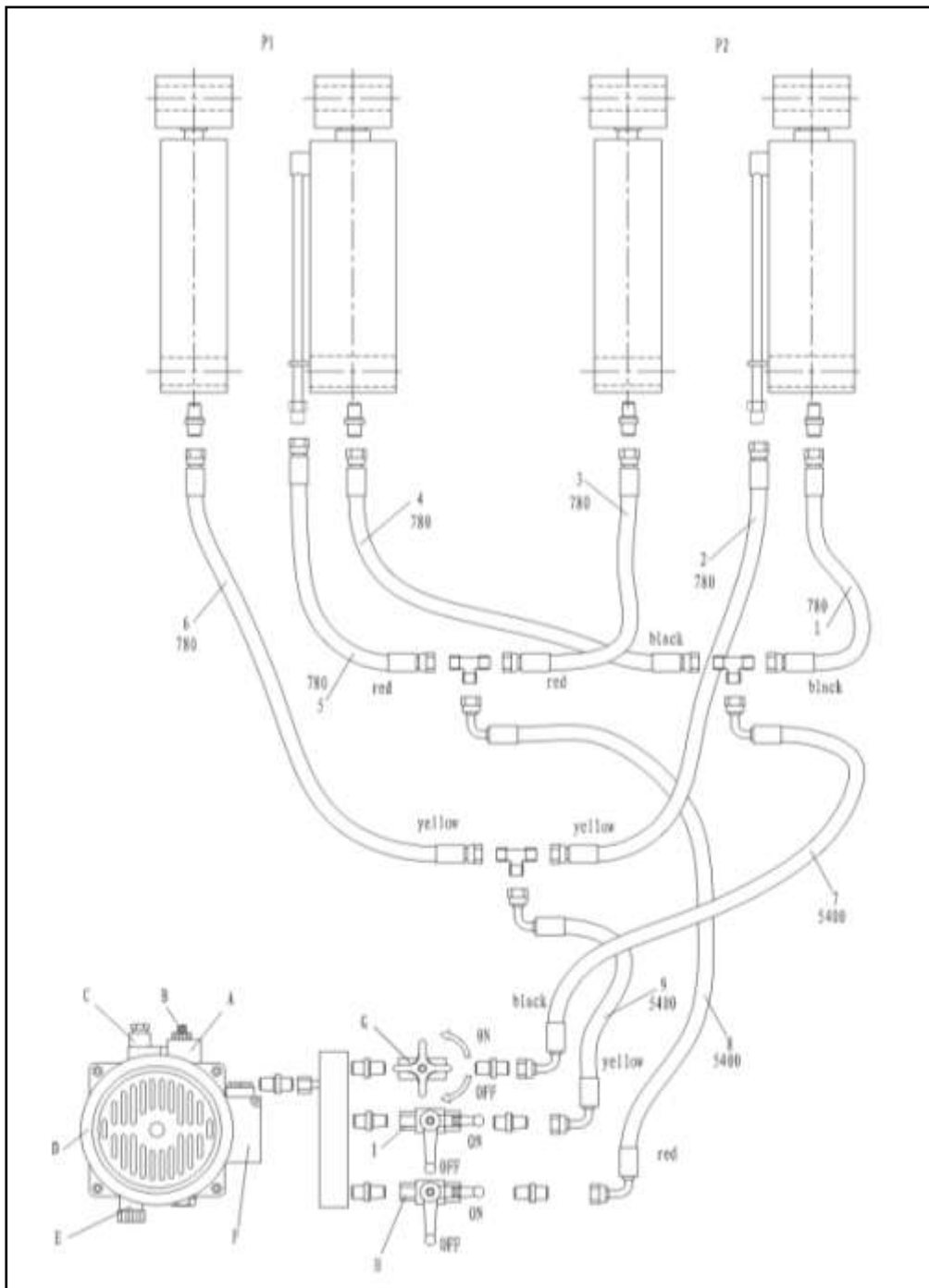

1. 1#~9# high pressure pipe

A: descent valve; B: manual descent knob; C: valve plug; D: motor; E: overflowing valve; F: joint wire box; G: adjusting valve; H,I: the oil make-up stop valve

ACCESSORY

Explosion diagram 1

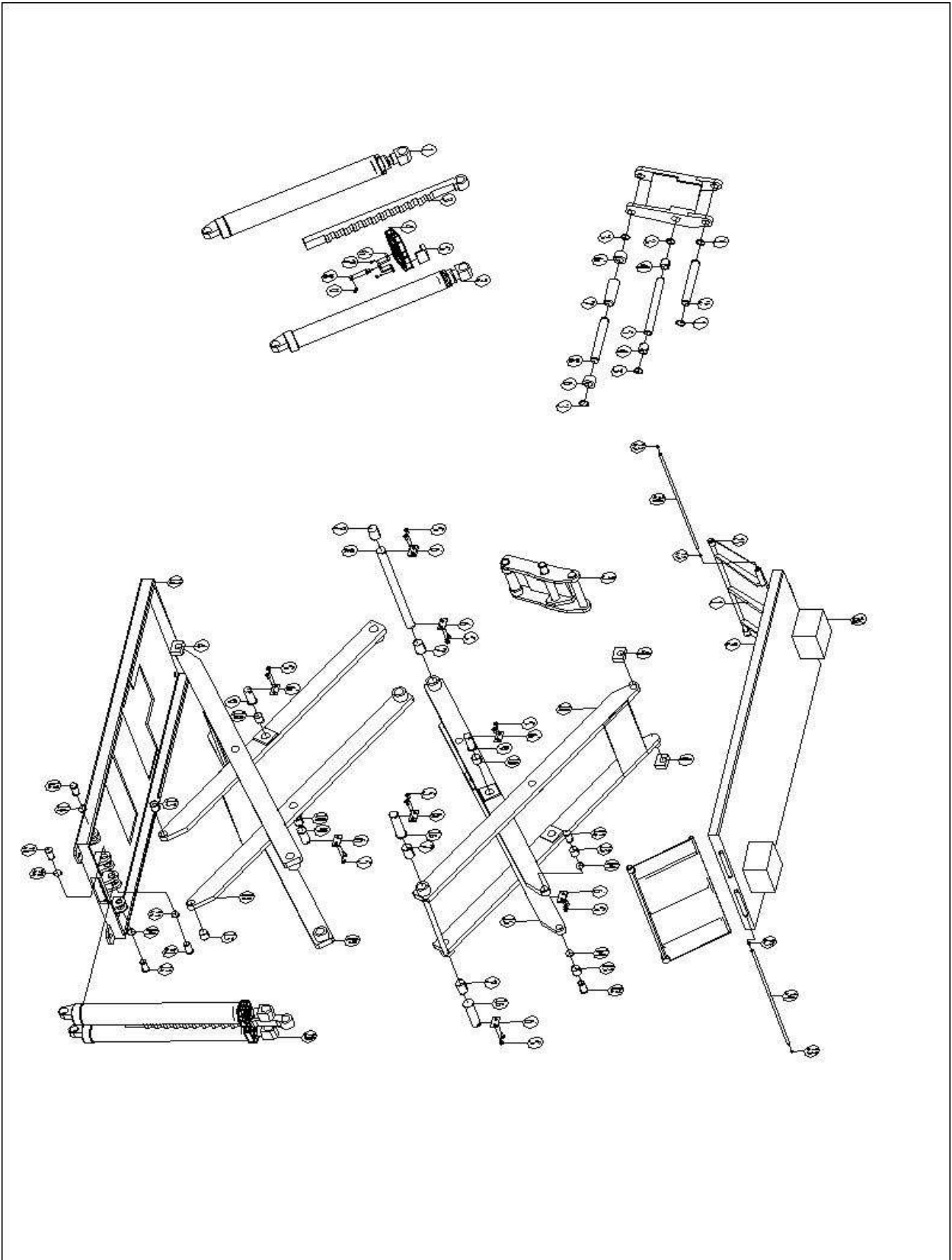

Explosion diagram 2

