

■ INFRARED THERMOMETER

# CA870

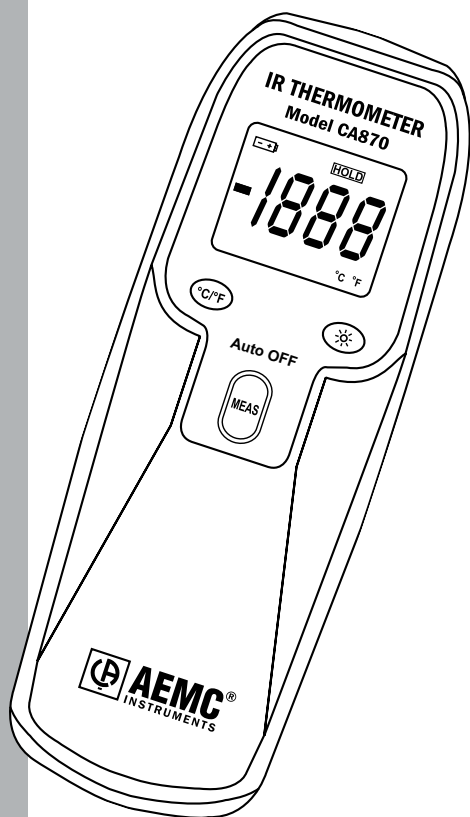

**Owner's Record**

The serial number for the Model CA870 is located inside the battery compartment of the instrument. Please record this number and purchase date for your records.

**INFRARED THERMOMETER MODEL CA870**

**CATALOG #: 2121.30**

**SERIAL #:** \_\_\_\_\_

**PURCHASE DATE:** \_\_\_\_\_

**DISTRIBUTOR:** \_\_\_\_\_

# Table of Contents

---

---

<b>1. INTRODUCTION.....</b>	<b>2</b>
1.1 Receiving Your Shipment.....	3
1.2 Ordering Information.....	3
<b>2. PRODUCT FEATURES.....</b>	<b>4</b>
2.1 Description.....	4
2.2 Button Functions.....	5
2.2.1 Center (Yellow) Button - MEAS.....	5
2.2.2 °C/°F Button.....	5
2.2.3 Back-light Button.....	5
<b>3. SPECIFICATIONS.....</b>	<b>6</b>
3.1 Electrical Specifications.....	6
3.2 General Specifications.....	7
3.3 Safety Specifications.....	7
<b>4. OPERATION.....</b>	<b>8</b>
4.1 Measurement Considerations.....	8
4.2 Recommendations before Operating.....	8
4.3 Operating Instructions.....	9
<b>5. MAINTENANCE.....</b>	<b>10</b>
5.1 Replacing the Battery.....	10
5.2 Cleaning.....	10
Repair and Calibration.....	11
Technical and Sales Assistance.....	11
Limited Warranty.....	12
Warranty Repairs.....	12

## **INTRODUCTION**



- Thermometers are not designed to touch live electrical samples.
- To prevent sensor damage, do not point the sensor lens directly at the sun or any other source of strong infrared light.
- Do not place the infrared thermometer directly on or close to objects at temperatures exceeding 158°F (70°C)
- To prevent measurement errors, do not expose the thermometer to strong electrical or electromagnetic fields.
- To prevent sensor damage and erroneous readings, do not put the sensor lens into contact with any body or foreign/loose material when measuring. Keep the sensor perfectly clean.
- Do not touch the sensor when taking measurements as it may affect the readings.
- When the meter is exposed to sudden temperature changes (hot or cold), allow 20 minutes of stabilization before taking a reading.
- Be certain there is no condensation on the lens prior to taking measurements. Allow 10 minutes for condensation to dissipate as needed.
- The Model CA870 is not waterproof or dust-proof. Take necessary precautions to protect it in wet or dusty environments.

### **1.1 International Electrical Symbols**



This symbol on an instrument indicates a **WARNING** and that the operator must refer to the user manual for instructions before operating the instrument. In a manual, the symbol preceding instructions indicates that if the instructions are not followed, bodily injury, installation/sample and product damage may result.

## 1.2 Receiving Your Shipment

Upon receiving your shipment, make sure that the contents are consistent with the packing list. Notify your distributor of any missing items. If the equipment appears to be damaged, file a claim immediately with the carrier and notify your distributor at once, giving a detailed description of any damage. Save the damaged packing container to substantiate your claim.

## 1.3 Ordering Information

**Infrared Thermometer Model CA870..... Cat. #2121.30**  
*Includes 9V Alkaline battery, rugged, shockproof, protective holster and user manual.*

## **PRODUCT FEATURES**

### **2.1 Description**

The Model CA870 is a portable, easy-to-use, compact-sized digital infrared thermometer designed for simple one-hand operation.

It uses an infrared sensor with a fixed emissivity of 0.95. The thermometer is simply aimed at the target to be measured without any physical contact (non-contact temperature measurement).

The thermometer is supplied with a protective holster, built-in sensor and also features a back-lit LCD display, an automatic data HOLD function, and Auto-OFF.

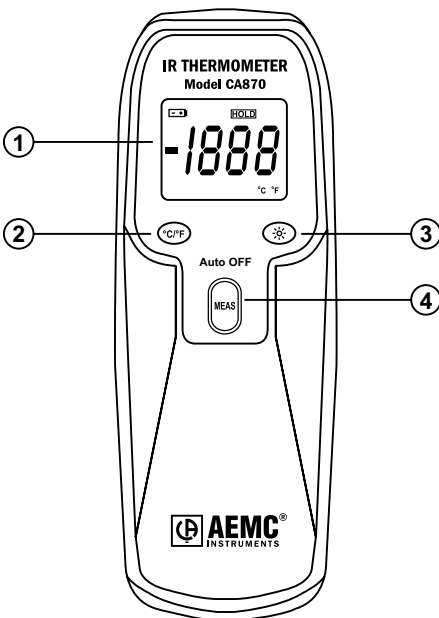

1. 3½ digit display
2. Temperature selector
3. Back-light button
4. Power/measure button

## 2.2 Button Functions

### 2.2.1 Center (Yellow) Button - MEAS

Press this button to turn the thermometer ON and perform a measurement. When the button is released, the meter will automatically HOLD (freeze) the last reading on the display for approximately 20 seconds before automatically shutting OFF.

### 2.2.2 °C/°F Button

Pressing this button makes the thermometer toggle between °F and °C. The selected temperature type is displayed in the lower right hand corner of the LCD. At power-up, the thermometer is in °C by default.

### 2.2.3 Back-light Button

Press the  button to turn the Back-light ON. Press again to turn OFF.

**NOTE:** There is no ON/OFF button. The thermometer turns ON when the center “MEAS” button is pressed, and will automatically shut OFF after 20 seconds.

## **SPECIFICATIONS**

### **3.1 Electrical Specifications**

**Temperature Range:** -4° to 500°F (-20° to 260°C)

**Display Resolution:** 1°F/°C

**Accuracy:**

±2% of reading or ±6°F (3°C), whichever is greater @ 64.4 to 82.4°F (18 to 28°C) ambient operating temperature.

**Temperature Coefficient:**

Changes in accuracy operating temperature above 82.4°F (28°C) or below 64.4°F (18°C): ±0.2% of reading or ±0.36°F (0.2°C), whichever is greater.

**Response Time:** 1 second

**Spectral Response:** 6 to 14μm nominal

**Emissivity:** Preset @ 0.95

**Detection Element:** Thermopile

**Optical Lens:** Fresnel Lens

**Field of View (FOV) ratio:**

10:1 (Distance : Diameter)

The FOV is the ratio of the distance to the target to the target diameter. When the target diameter is small, it is important to bring the thermometer closer to the target to ensure that only the target is measured, excluding the surroundings. Remember that the measurement size is one-tenth the distance to the target. For example, if the thermometer is at 10", then the size measured is 1".

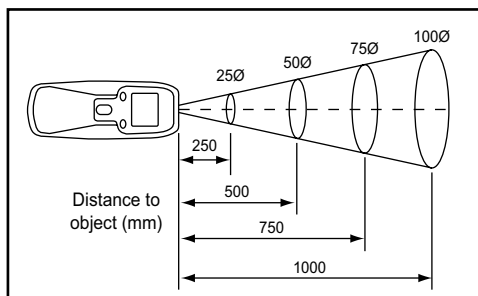



## 3.2 General Specifications

**Display:** 3½ digit liquid crystal display (LCD) with maximum reading of 1999

**Low Battery Indication:**  is displayed when battery voltage drops below required level

**Sample Rate:** 2.5 times per second, nominal

**Operating Temperature:** 32° to 122°F (0° to 50°C) at < 80% RH

**Storage Temperature:**

-4° to 140°F (-20° to 60°C), 0 to 80% RH with battery removed

**Auto Power Off:** 15 seconds approx

**Altitude:** 2000m max

**Input Protection:** 24V<sub>DC</sub> or 24rms maximum input voltage on any combination of inputs

**Battery:** Standard 9V battery (NEDA 1604, 6LR61 or equivalent)

**Battery Life:** 100 hours (continuity) typical with carbon zinc battery (back-light not illuminated)

**Dimensions:** 6.81 x 2.38 x 1.5" (173 x 60.5 x 38mm)

**Weight:** Approx 6.5 oz (183g) including battery

## 3.3 Safety Specifications



EN 61010-1 (1995-A2), Protection Class III

Overvoltage Category (CAT III, 24V), Pollution Degree 2

Indoor Use

*\*All specifications are subject to change without notice*

## **OPERATION**

### **4.1 Measurement Considerations**

**MEASUREMENT THEORY:** Every object emits infrared (IR) energy proportional to its temperature. By measuring the amount of this radiant energy, it is possible to determine the temperature of the emitting object. Infrared radiation is invisible light (electromagnetic radiation), which easily travels through air and is easily absorbed by solid matter. An IR thermometer, which operates by detecting infrared radiation, can accurately measure an object surface temperature without touching it and independently of the air temperature or the measurement distance.

Infrared radiation, which is emitted from the object, is focused into an infrared radiation sensor through an optical system. This system includes an optical lens, which is transparent to infrared radiation, and a 5.3 $\mu$ m cut off filter. The output signal from the infrared radiation sensor is input to an electronic circuit, along with the output signal from a standard temperature sensor, to calculate the temperature and display it on the meter display.

### **4.2 Recommendations before Operating**

- If the measured surface target diameter is less than 2"/50mm  $\varnothing$ , then place the sensor as close as possible to the target surface (<20"/50cm away). See Field of View (FOV) information under Specifications.
- If the target surface is covered with frost or any matter, clean it before taking a measurement.
- If the target surface is highly reflective put some matte tape, or matte paint, over it before measuring.
- If the Thermometer is erratic, or seems not to be measuring properly, make sure that the sensor is clean and not covered by condensation.

### 4.3 Operating Instructions

1. Turn unit ON by pressing the yellow “MEAS” button.
2. Select °F or °C, by pressing the °F/°C button. The selected degree type is displayed in the lower right hand corner of the LCD.
3. Infrared thermometer sensors need a certain time stabilize to ambient temperature. Remember to let the IR meter reach ambient temperature if brought in from a different temperature environment.
4. Press the  button to turn ON the back-light if needed.
5. The thermometer will continue measuring as long as the MEAS button is pressed. When the button is released, the measurement will be held in the display for approximately 20 seconds.
6. The IR thermometer will shut OFF automatically after approximately 20 seconds.

#### **EMISSIVITY**

All objects emit invisible infrared energy. The amount of IR energy emitted is proportional to the object’s temperature and its natural ability to emit IR energy. This ability, called emissivity, is based upon the object material type and its surface finish. Emissivity values range from 0.10 for a very reflective object to 1.00 for a black body. Factory set emissivity value of 0.95 will cover 90-95% of typical applications.

If frost or other material/substance covers the measured surface, clean it to expose the surface. If the surface to be measured is highly reflective, apply dull masking tape or matte black paint over the surface. If the thermometer seems to be giving incorrect readings, check the front sensor. There may be condensation or debris obstructing the sensor. Only clean per instructions.

Material	Emmissivity
Asphalt	0.90 to 0.98
Concrete	0.94
Cement	0.96
Sand	0.90
Earth	0.92 to 0.96
Water	0.92 to 0.96
Ice	0.96 to 0.98
Snow	0.83
Glass	0.90 to 0.95
Ceramic	0.90 to 0.94
Marble	0.94
Plaster	0.80 to 0.90
Mortar	0.89 to 0.91
Brick (red)	0.93 to 0.96

Material	Emmissivity
Cloth (black)	0.98
Human skin	0.98
Lather (Soap)	0.75 to 0.80
Charcoal (powder)	0.96
Lacquer	0.80 to 0.95
Lacquer (matte)	0.97
Rubber (black)	0.94
Plastic	0.85 to 0.95
Timber	0.90
Paper	0.70 to 0.94
Chromium oxide	0.81
Copper oxide	0.78
Iron oxide	0.78 to 0.82
Textiles	0.90

## **MAINTENANCE**

Use only factory specified replacement parts. AEMC® will not be held responsible for any accident, incident, or malfunction following a repair done other than by its service center or by an approved repair center.

### **5.1 Replacing the Battery**

The  symbol appears on the LCD display when replacement is needed. Replace with a standard 9-volt battery (NEDA 1604, 6LR61).

#### **To replace the battery:**

- Turn the meter OFF.
- Remove the rubber holster.
- Remove the screw from the back of the meter and lift off the battery cover.
- Replace the battery, then put the rear cover and holster back on.

### **5.2 Cleaning**

- Use a soft cloth lightly dampened with soapy water.
- Rinse with a damp cloth and then dry with a dry cloth.
- Do not use any abrasives or solvents.
- Do not let any liquid enter the case or sensor area.

## **Repair and Calibration**

To ensure that your instrument meets factory specifications, we recommend that it be scheduled back to our factory Service Center at one-year intervals for recalibration, or as required by other standards or internal procedures.

### **For instrument repair and calibration:**

You must contact our Service Center for a Customer Service Authorization Number (CSA#). This will ensure that when your instrument arrives, it will be tracked and processed promptly. Please write the CSA# on the outside of the shipping container. If the instrument is returned for calibration, we need to know if you want a standard calibration, or a calibration traceable to N.I.S.T. (Includes calibration certificate plus recorded calibration data).

**Ship To:** Chauvin Arnoux®, Inc. d.b.a. AEMC® Instruments  
15 Faraday Drive  
Dover, NH 03820 USA  
Phone: (800) 945-2362 (Ext. 360)  
(603) 749-6434 (Ext. 360)  
Fax: (603) 742-2346 or (603) 749-6309  
E-mail: [repair@aemc.com](mailto:repair@aemc.com)

(Or contact your authorized distributor)

Costs for repair, standard calibration, and calibration traceable to N.I.S.T. are available.

**NOTE: You must obtain a CSA# before returning any instrument.**

## **Technical and Sales Assistance**

If you are experiencing any technical problems, or require any assistance with the proper operation or application of your instrument, please call, mail, fax or e-mail our technical support team:

Chauvin Arnoux®, Inc. d.b.a. AEMC® Instruments  
200 Foxborough Boulevard  
Foxborough, MA 02035 USA  
Phone: (800) 343-1391  
(508) 698-2115  
Fax: (508) 698-2118  
E-mail: [techsupport@aemc.com](mailto:techsupport@aemc.com)  
[www.aemc.com](http://www.aemc.com)

**NOTE: Do not ship Instruments to our Foxborough, MA address.**

## **Limited Warranty**

The Model CA870 is warranted to the owner for a period of one year from the date of original purchase against defects in manufacture. This limited warranty is given by AEMC® Instruments, not by the distributor from whom it was purchased. This warranty is void if the unit has been tampered with, abused or if the defect is related to service not performed by AEMC® Instruments.

**For full and detailed warranty coverage, please read the Warranty Coverage Information, which is attached to the Warranty Registration Card (if enclosed) or is available at [www.aemc.com](http://www.aemc.com). Please keep the Warranty Coverage Information with your records.**

### **What AEMC® Instruments will do:**

If a malfunction occurs within the one-year period, you may return the instrument to us for repair, provided we have your warranty registration information on file or a proof of purchase. AEMC® Instruments will, at its option, repair or replace the faulty material.

**REGISTER ONLINE AT:  
[www.aemc.com](http://www.aemc.com)**

## **Warranty Repairs**

### **What you must do to return an Instrument for Warranty Repair:**

First, request a Customer Service Authorization Number (CSA#) by phone or by fax from our Service Department (see address below), then return the instrument along with the signed CSA Form. Please write the CSA# on the outside of the shipping container. Return the instrument, postage or shipment pre-paid to:

**Ship To:** Chauvin Arnoux®, Inc. d.b.a. AEMC® Instruments  
15 Faraday Drive • Dover, NH 03820 USA  
Phone: (800) 945-2362 (Ext. 360)  
(603) 749-6434 (Ext. 360)  
Fax: (603) 742-2346 or (603) 749-6309  
E-mail: [repair@aemc.com](mailto:repair@aemc.com)

**Caution:** To protect yourself against in-transit loss, we recommend you insure your returned material.

**NOTE:** You must obtain a CSA# before returning any instrument.

**Notes:**

---

