

Please completely read and understand the entire manual before using, assembling and/or disassembling your remote controlled car.

## 1/8TH SCALE ELECTRIC POWERED 4WD SAND RAIL BUGGY

### INSTRUCTION MANUAL

# SAND RACER



#### Technical Data:

LENGTH	WIDTH	HEIGHT	WHEELBASE	WHEEL DIA.	WHEEL SPAN	GEAR RATIO
535MM	297MM	190MM	340MM	109MM	42MM	1: 12.59

This data is subject to change without prior notice.

#### Features:

- Four Wheel Drive System
- Full Aluminum Oil Filled Shocks
- 6KGs Steering Servo
- Factory-Assembled with Factory-Printed Body
- 2.4GHz Radio System
- Bevel Differentials, Front And Rear
- Adjustable Camber, Front And Rear
- Adjustable Bump Steer, Shock Mounting Positions And Droop
- Adjustable Differentials With The Use Of Differential Grease
- High-Grip, All-Terrain Tires Mounted On Spoke Type Wheels
- Uses Li-po Battery ( 11.1V, 3000mAH) and Li-po Pocket Charger (Battery and charger need to be separately purchased)

This product is not a toy. It is not intended for persons under 14 years of age, unless closely supervised by an adult.

This manual is subject to change without notice.



## GENERAL INFORMATION

- This user's manual contains the instructions you will need to assemble, operate and maintain your vehicle. We know you are anxious to start driving, but it is very important that you take time to read the manual even if you are an experienced R/C driver.
- Carefully read and follow all instructions in the manual. Failure to follow the instructions will be considered abuse and/or neglect and may void the warranty.
- Your vehicle is designed to run on uneven or rough terrain. However, dust, sand, water and carpet fibers can lodge in any moving parts and can damage your vehicle if not removed promptly. Your warranty does not cover damage due to outside elements including sand, dirt, water or any other debris. You are responsible for the maintenance and safe operation of this vehicle.
- This product is not a toy. It is not suitable for users under 14 years old unless supervised by an adult.
- Never attempt to re-assemble any electronic components. These have been carefully calibrated at the factory.
- Only use our factory manufactured parts to upgrade your car. If you perform a drive train upgrade, replace the entire system (Such as motor, ESC/receiver unit and the like) so that all components are properly matched. Any malfunction incurred by custom modification will void your warranty.
- Before driving your vehicle, please read this manual completely and examine your vehicle for any defects. Test your remote control to make sure it functions properly and at the range you plan to run your vehicle.
- For best performance, some adjustments may be necessary.
- This vehicle requires one battery pack, which is included with the car. The radio controller requires three AA size batteries (not included). Make sure the vehicle's batteries have a sufficient charge before driving or possible loss of control may result.
- Always remove batteries from the vehicle and the radio controller when not in use.
- Please operate your vehicle in an open area free of obstacles. Never operate your vehicle in crowded street.
- This product is fully assembled at factory. our factory is not responsible for damage and/or accidents that occur as the result of custom modifications and/or incorrect operation.



## SAFETY INFORMATION

We want you to enjoy your R/C vehicle and to operate it with care. Failure to operate your vehicle in a safe and responsible manner may result in injury to yourself and others and may cause damage to property.

- Read and understand all instructions carefully before use and assembly/disassembly.

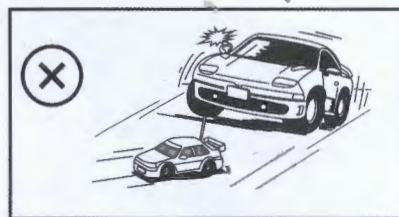

- Do not run your vehicle on public roads or any area where you may encounter pedestrian or vehicle traffic.

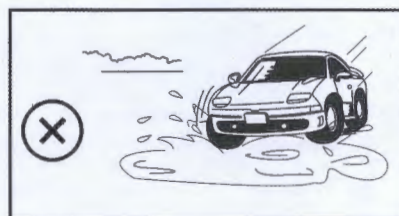

- Do not operate in a congested area or in crowds.

- Do not operate your vehicle with obstructed line of sight, at night, or near water.



- Your vehicle is radio controlled. Radio waves are subject to interference. Radio interference can cause loss of control of your vehicle.

- Take care not to injure yourself while using tools to adjust or upgrade your vehicle.

- Since the model contains many small parts, keep out of reach of children while assembling and/or disassembling.



- When turning off your model, always turn off the receiver first, before turning off the remote control.

- Always remove the batteries from your vehicle and the remote control when not in use.

- If your vehicle becomes stuck, release the throttle, then retrieve it by hand.

- Do not continue to apply the throttle or you may damage the motor and/or the ESC/receiver unit.

- Turn off your vehicle and discontinue use if it runs erratically. Do not run it again until the issue has been found and resolved.



## FAMILIARIZING YOURSELF WITH YOUR 2.4GHz RADIO SYSTEM

Your car is equipped with the new 2.4GHz radio system. Please read and understand all instructions below before operating.

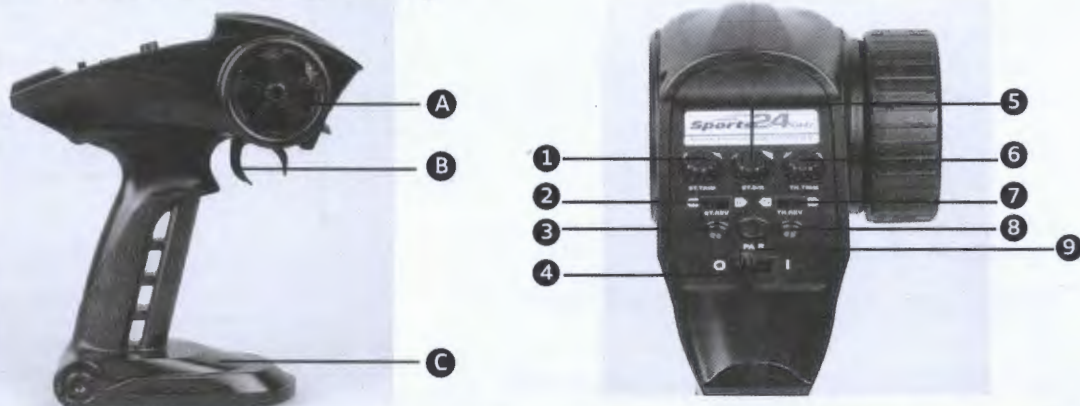

<b>A: Steering Wheel</b>	<b>1: Steering Trim</b>	<b>4: Power Switch</b>	<b>7: Throttle Reverse</b>
<b>B: Trigger</b>	<b>2: Steering Reverse</b>	<b>5: Steering Dual Rate</b>	<b>8: Green Indicator</b>
<b>C: Battery Case</b>	<b>3: Red Indicator</b>	<b>6: Throttle Trim</b>	<b>9: Bind(Pair) button</b>

**Steering Wheel:** Proportionally operates the models right and left steering control.

**Battery Case:** Requires 3pcs of AA size batteries.

**Power Switch:** Used to turn the radio controller ON/OFF

**Steering Dual Rate Dial:** Allows you to change the amount of steering servo travel compared to the amount of physical movement of the steering wheel.

**Throttle /Steering Trims:** Used to adjust the center trim of the throttle/steering channel.

**Steering Reverse:** Allows you to electronically switch the direction of steering servo travel. For example, if you move the steering wheel to the right and the steering servo moves to the left, flip the Steering Reverse Switch to make the steering servo move to the left.

**Throttle Reverse :** Allows you to electronically switch the direction that the motor operates in relation to the throttle trigger. For example, if you pull the throttle trigger to accelerate forward, but the model goes in reverse, flip the Throttle Reverse Switch to make the model accelerate forward.

**Trigger:** Controls the speed and braking ability of your car. Pull it to accelerate, release it to decelerate, and push it to brake. Pushing it a second time activates the reverse feature.

**Indicators:** Shows battery power level. Green indicator flashing means battery power is low. If both red and green indicators are flashing then the radio controller battery is too low to control the model and you must replace with fresh batteries immediately.

**Bind(Pair) button:** It is used to bind your 2.4GHz radio system.

### BATTERY INSTALLATION

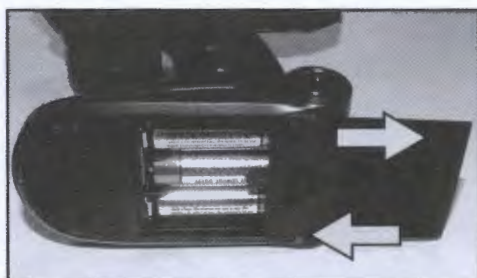

- 1) Slide the battery cover as shown and install 3pcs of AA size batteries, positioning the polarity as indicated.
- 2) Replace the battery cover after batteries are installed.

#### NOTES:

- Use batteries of same type.
- Remove batteries from the case if not in use.
- Always check the battery power.
- Dispose of exhausted batteries properly.



## TO BIND THE RECEIVER TO THE RADIO CONTROLLER

Before running, make sure that the radio controller is bound with the receiver. This has been done at the factory, but if the model is not responding to the controller, it is possible that the controller and receiver are not bound, and you must perform the binding procedure following the instructions below.



BIND BUTTON ON RECEIVER



Press the BIND button a second time to activate FAIL SAFE feature by the time the binding process is completed.



Press and hold

1) Press and hold the Bind Button on the receiver by using a screwdriver as shown, while turning on the power switch on the car. (The power switch is located on the rear indicated by label.)



Located inside



2) Hold the Bind(Pair) key and switch on the power on the radio controller. You must hold the Bind(Pair) within 5 seconds of turning on the receiver on the car.



3) The green indicator should flash, meaning that the binding process is being performed.



4) Once both red and green indicator are lit and not flashing, then your receiver is bound to your radio controller. The binding process is complete.

## RUNNING YOUR CAR

1) TURN ON THE RADIO CONTROLLER

2) TURN ON THE RECEIVER ON YOUR CAR

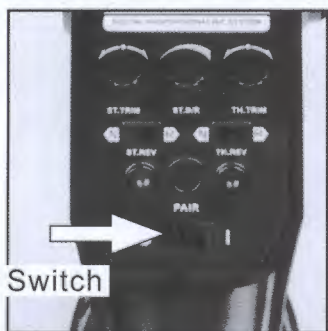

Power Switch



Located inside



## NOTES:

- Before using your car, make sure the radio controller has sufficient battery power. If the battery power is too low it can lead to the loss of control of your car.
- Always turn on the remote controller **FIRST**, and then the receiver.

### 3 CHECK STEERING PERFORMANCE

- Ensure good steering performance.



1) To keep the car running in a straight line, do not move the control wheel. (Keep it centered)

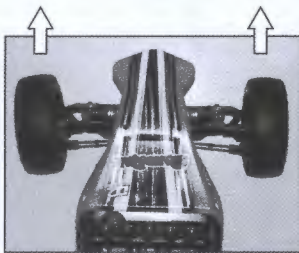

2) Turn the control wheel left to allow your vehicle to turn left.

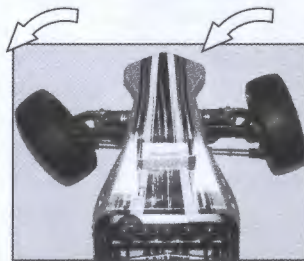

3) Turn the control wheel right to allow your vehicle to turn right.

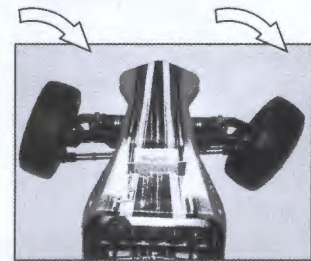

### 4 CHECK TRIGGER RESPONSE

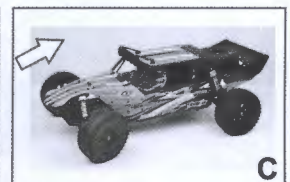
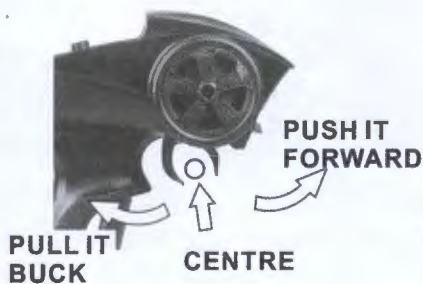

- A. Pull the trigger back to accelerate, release it to decelerate and push it forward to brake.
- B. To stop accelerating your car, release the trigger to Neutral.
- C. Pushing the trigger forward a second time activates the reverse feature.

### 5 TO TUNE THE STEERING TRIM

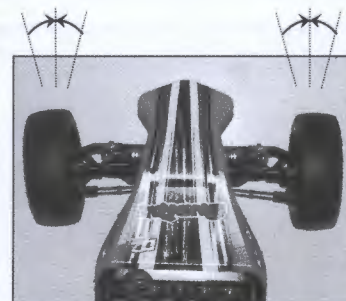

Gently pull the trigger to allow your car to accelerate slowly. Meantime, tune the steering trim to align the front wheels.



## 6 TO TUNE THE STEERING DUAL RATE CONTROL DIAL

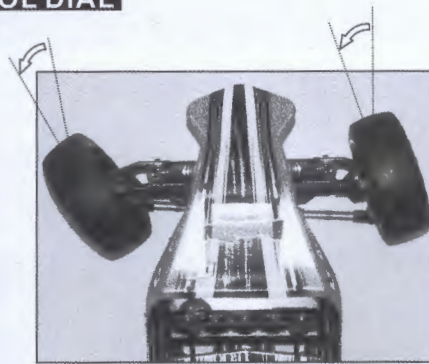
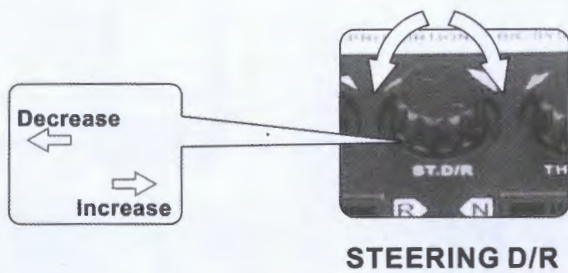

This dial adjusts the overall travel of the steering servo. Push the dial forward for maximum steering. Pull the dial back to reduce the steering level.

- Set the Steering Dual Rate Control Dial to Minimum first. To set the desired steering level increase it again whilst decelerating your vehicle.

## BATTERY INSTALLATION



Follow the illustrations above to install the Li-po battery pack in your car. The battery cover is located on the bottom of the chassis.

- 1) Pinch the battery cover blocks as shown to open the battery cover. (See Figure 1)
- 2) Lift the battery cover. (See Figure 2)
- 3) Connect the battery to the ESC as shown. Note: The vehicle uses banana plugs--make sure to connect black to black and red to red..(See figure 3)
- 4) Install the battery foam and replace the battery cover. ( See Figure 4)

## CHARGING THE BATTERY PACK

Your RTR vehicle is equipped without battery and charger unless individually purchased. Here is our practical pocket Li-po battery charger which you might use with your vehicle.

Input Voltage: 110-240 V AC

Output Current: 1.0 A

Indicator: 3× LED

Max. Charging Current: 1.0 A

Size: 100 mm \* 60mm \* 35 mm

Weight: Approx. 180g



Power Supply Slot

Charging Indicators

Slot A for 2S li-po  
(7.4V)

Slot A for 3S li-po  
(11.1V)





1) Connect the pocket balance charger to power supply by using the power supply cord provided in the package.  
The indicator lights will turn green meaning that the charger is ready.



2) Connect the battery to the corresponding slot. (If it is 3S(11.1V) battery, please connect it to 3S slot...)

When the battery is initially connected, the indicator lights will turn Red meaning that charging has begin. Once the battery is fully charged, the indicator lights will turn green again.



Note: The batteries use banana plugs--make sure to connect black to black and red to red.



### Warning

- Ensure all cords are connected firmly during charging.
- Never touch the charger with wet hands.
- Never charge battery unattended.
- Store the charger in a dry place away from direct sunlight.  
Never use it near any source of heat and water.
- Children must not handle the charger without adults' supervision.

## STOPPING YOUR CAR

### 1) TURN OFF THE RECEIVER ON YOUR CAR



### 2) TURN OFF THE RADIO CONTROLLER

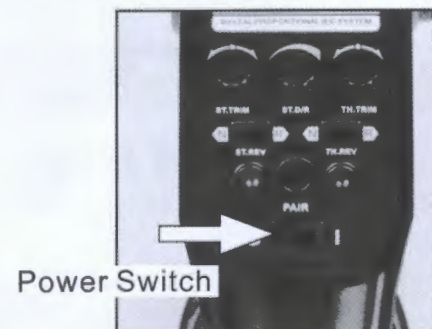

### CAUTION

- Always switch off the receiver ,and then the radio controller.

### 3) REMOVE BATTERIES

- Do not forgot to remove batteries from your car and radio controller when not in use.



## TO ACCESS THE MOTOR AND ESC

This vehicle is fully assembled at factory. The following illustrations facilitates replacement. (Note: For these plum/star head screws, you can use either Standard Hex Screw drivers (1.5mm, 2mm, 2.5mm) or Plum/Star Head screwdrivers.).



First remove the roll cage:



1) Remove the eight screws (69586) from the chassis as shown in the figure one by one.

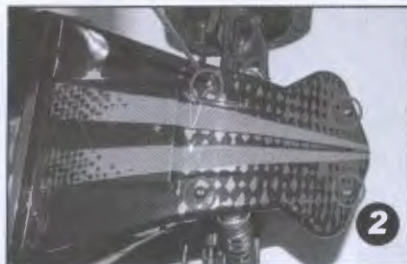

2) Remove the four screws (69580) from the hood as shown in the figure one by one.



3) Remove the screw (69590) from the rear unit on the one side as shown in the figure.



4) Remove the screw (69590) from the rear unit on the other side as shown in the figure.



5) Remove the rear shock from one side using needle nose pliers.



6) Remove the rear shock from the other side using needle nose pliers.



7) Hold the rear suspension, remove the roll cage from one side.



8) Push gently on the other side to remove the roll cage as shown in the figure.

The roll cage is removed from vehicle. You are now ready to check motor and ESC if possible. To replace the roll cage follow the steps again in reverse.

Tip: Before re-installing the roll cage, check all parts carefully and make sure they have not come loose and are properly secured.



## CHASSIS TUNING GUIDE

Your model can be customized to enhance speed and performance. Simple adjustment and easily maintained setting will assure optimum operation and performance. When making adjustments, do so only in small increments and always check for other parts of the vehicle that are affected. Many after market options are available to make your R/C vehicle faster and stronger. Please read the section carefully and it always make sure you write down your base settings in case you need to refer to them at a later date.

### Front Steering Toe Angles

The front steering toe angle has a dramatic on how your car performs and how your tires wear. You can have toe-in, zero toe or toe-out. This can be adjusted by turning the front turning linkage set with an adjustable wrench.

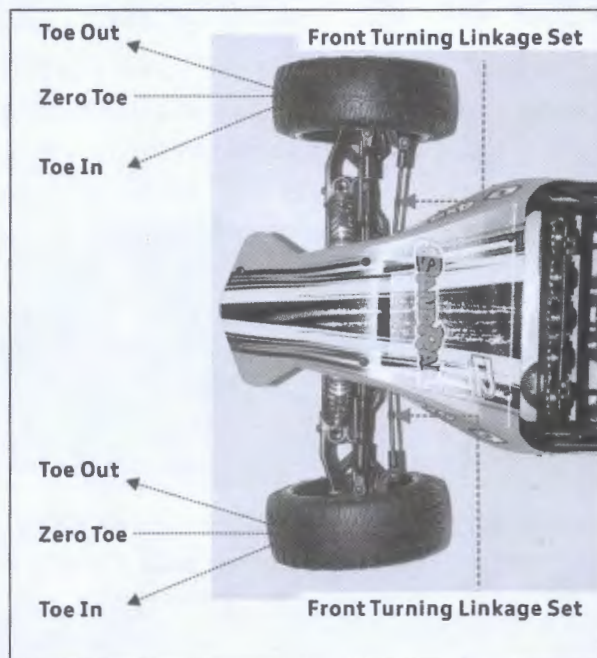

Toe-in will be less reactive and cause the vehicle to under steer (the front wheels push straight on while turning).

This can be advantageous for operators struggling to get to grips with the driving of the vehicle.

Toe-out will be more aggressive on the steering response especially on small steering inputs. This will make the car want to over steer (rear wheels slide on small steering inputs). This is useful as a race tuning aid to gain extra steering.

Zero toe will make the front wheels run straight and make the car very neutral. Tire wear will also be reduced and the vehicle will feel easier to drive.

### Camber Adjustment

Camber can be adjusted on all 4 wheels of the car. You can have negative camber or positive camber which will affect the contact patch of the tire both statically and while cornering. Camber is mainly used to control the wear of the tire. You should adjust the camber to equal the wear all across the surface of the tire. Camber is adjusted by the upper link turnbuckle linking the wheel to the chassis front and rear.

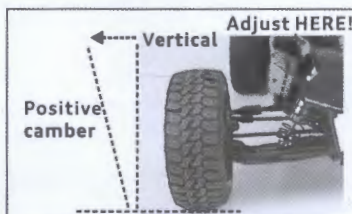

This is an example of positive camber.

This is when the bottom of the wheel is closer to the centre of the car compared to the top of the wheel. Positive camber will give less contact area in the corner and less grip. Excessive amounts will cause less grip and uneven wear.



This is an example of negative camber.

This is when the top of the wheel is closer to the centre of the car compared to the bottom of the wheel. Negative camber will give more contact area in the corner and more grip. Excessive amounts will cause less grip and uneven wear.



## INSTALLING OFF-ROAD LIGHT LENSES (FRONT/REAR)

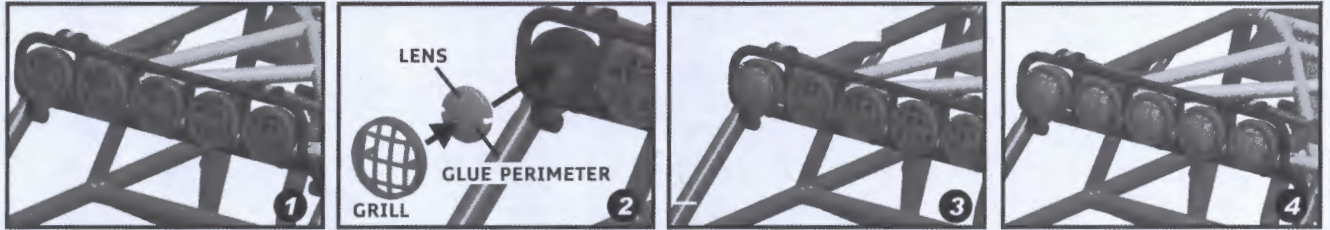

### GLUE THE OUTER PERIMETER OF THE LENS AND INSTALL

The off-road light lenses are optional parts.

1. Remove the five off-road light grills. (fig.2)
2. Apply a small bead of glue (CA) around the outer perimeter of the first lens. (fig.2)
3. Carefully line up the notches in the lenses with the tabs inside the light housing and install.
4. Repeat steps 2-3 for remaining four front lenses.
5. Reinstall off-road light grills. (fig.4)
6. Apply a small bead of glue (CA) around the outer perimeter of the first rear lens. (fig. 5)
7. Align the lens with the rear light housing and push into place.
8. Repeat steps 6-7 for the remaining three rear lenses.



## RADIATOR ASSEMBLY AND INSTALLATION

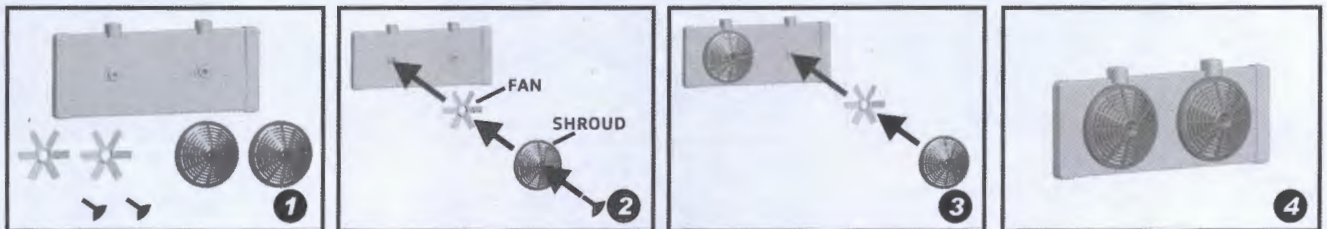

The radiator is an optional part.

1. Gather all five parts of the radiator assembly. (fig.1)
2. Align the fan and shroud onto the radiator shaft. (fig.2)
3. Using a torque driver, insert the (69600) torque screw into the end of the shroud and tighten.
4. Repeat steps 2-3 to complete the radiator assembly. (fig.3)

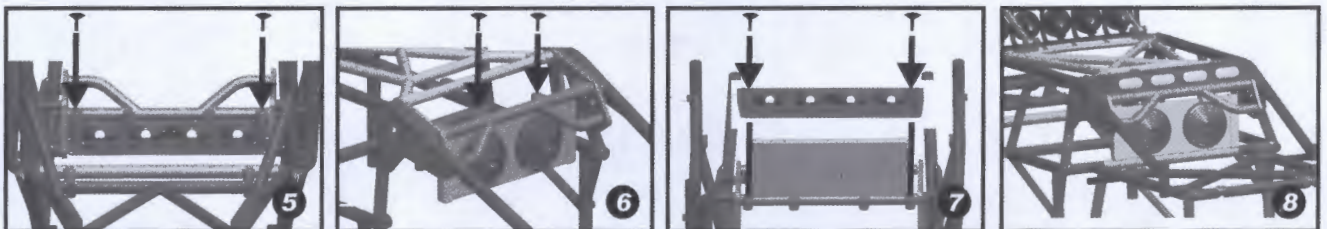

5. Using a torque driver, remove the rear light assembly by removing the two screws securing it from the underside of the roll cage. (fig.5)
6. Fasten the radiator assembly from the top using two (69593) screws. (fig.6)
7. Reinstall the rear light assembly. (fig.7)



## COCKPIT INSTALLATION

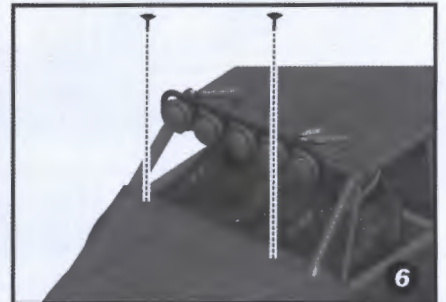
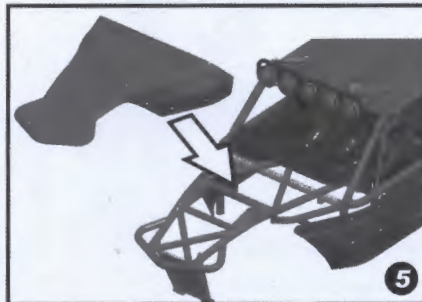
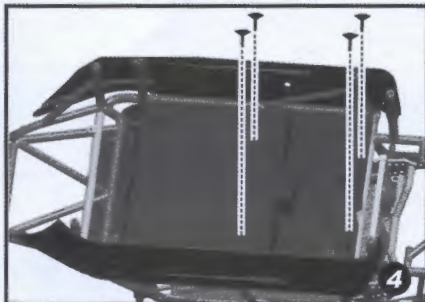
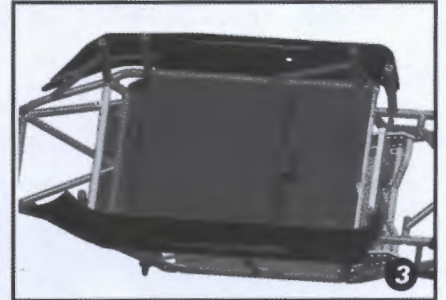
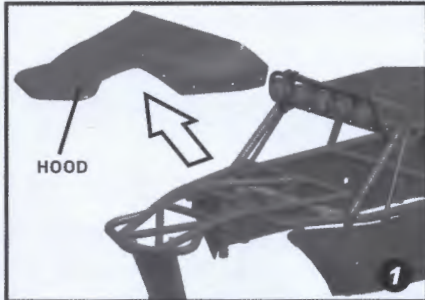
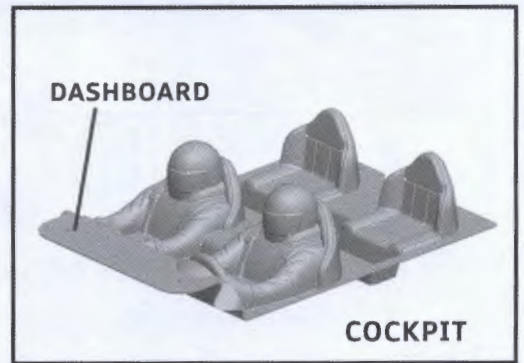

The cockpit is an optional part.

1. Uninstall the roll cage from the chassis.
2. Remove all 14 screws securing the hood and remove from roll cage. (fig.1)
3. Insert the cockpit into the underside of the roll cage (fig.2), be sure the front of the dashboard is on top of the roll cage. (fig.3&5)
4. Secure the cockpit from the underside using the included (69610) screws. (fig.4)
5. Reinstall the front hood and secure in place. Be sure the two rear holes of the hood line up with two holes in the dashboard. (fig.5-6)



## MAINTAINING YOUR CAR

After running your car, perform the following procedures regularly to maintain your car's performance.

- Inspect your car for any obvious damage.
- Check the gears for wear, debris or broken/slipping teeth.
- Check the wheels and tighten the wheel screws properly.
- Check for loose screws in the chassis.
- Check the wiring for frayed or damaged wires or connectors.
- Check the steering servo which will wear out over time and require replacement.
- Check all batteries.
- Keep the chassis clean and free of sand, dust, moisture and any other debris.  
Remove and clean the motor if necessary. (Never attempt to re-assemble the motor, you will damage it and void the warranty).
- Clean the car body with a soft lint-free cloth.
- Remove all batteries from the car when not in use.

## TROUBLESHOOTING

A. The vehicle does not work at all.

1. Check to see if radio controller and car are on.
2. Check to see if radio controller and receiver are properly bound.
3. Adjust throttle trim on the radio controller
4. Replace batteries.

B. The vehicle runs slow.

1. Replace or charge the battery pack and/or the radio batteries.
2. Make sure the vehicle is geared properly and the pinion and spur gear are over tightened.
3. Clean all bushings or ball bearings.
4. Check for stripped or dirty gears.

C. The throttle works, but not the steering.

1. Check if the servo feels jammed, try centering carefully it by hand.
2. Check all the steering linkage for any damage.

D. It steers, but no throttle control.

1. Adjust the throttle trim.
2. Replace or charge the battery pack and/or the radio batteries.

E. The vehicle runs noisily.

1. Check gear mesh between spur gear and pinion.
2. Check for stripped and/or dirty gears.
3. Clean and oil bushings or ball bearings.



# LIST FOR REPLACEMENT PARTS

<p><b>69500R</b></p>  <p>Chassis</p>	<p><b>69501R</b></p>  <p>Roll Cage Side Units</p>	<p><b>69502</b></p>  <p>Roll Cage Front Unit Roll Cage Top Unit</p>	<p><b>69503</b></p>  <p>Roll Cage Rear Unit+ Spare Tire Post+Retainer</p>
<p><b>69504R</b></p>  <p>Front Bumper Brace &amp; Roll Cage Side Rails Assembly</p>	<p><b>69505R</b></p>  <p>Roll Cage Rear Rails Assembly</p>	<p><b>69506</b></p>  <p>Shock Towers (Fr.&amp;Rr.)</p>	<p><b>69507R</b></p>  <p>Gear Box Assembly</p>
<p><b>69508</b></p>  <p>Suspension Arms (Lower Front)</p>	<p><b>69509</b></p>  <p>Suspension Arms (Lower Rear)+Shock Retainers</p>	<p><b>69510</b></p>  <p>Steering Knuckles Rear Hub Carriers</p> <p style="text-align: right;">Left/Right</p>	<p><b>69511</b></p>  <p>Front Hub Carriers</p> <p style="text-align: right;">Left/Right</p>
<p><b>69512R</b></p>  <p>Suspension Arms (Lower Rear)+Shock Retainers</p>	<p><b>69513</b></p>  <p>5pur Gear ( 56T)</p>	<p><b>69514R</b></p>  <p>Centre Diff. Mount Set+ Suspension Mount Set+Servo Retainers+Centre Diff. Retainer</p>	<p><b>69515</b></p>  <p>Servo Saver Assembly A + Bumper Lowe Mount Set+ Servo Arm</p>
<p><b>69516R</b></p>  <p>Battery Guard+ESC Bottom Mount</p>	<p><b>69517RA</b></p>  <p>Front/rear light assembly</p>	<p><b>69517RB</b></p>  <p>Radiator Assembly+ Screws</p>	<p><b>69518</b></p>  <p>Off Road Buggy</p>

NOTES: THE IMAGES OF THE PARTS MAY VARY FROM YOUR ACTUALLY RECEIVED PARTS.



# LIST FOR REPLACEMENT PARTS

<p><b>69519</b></p>  <p>Wheels -Spoke Style</p>	<p><b>69520</b></p>  <p>2P</p> <p>Tires/Sponge Insert</p>	<p><b>69521</b></p>  <p>2P</p> <p>Wheels Complete</p>	<p><b>69522</b></p>  <p>Centre Diff. Complete</p>
<p><b>69523</b></p>  <p>Battery Cover (assembled)</p>	<p><b>69524R</b></p>  <p>69.6mm (front) 161.6mm (rear)</p> <p>2P</p> <p>Center Drive Shafts (Front and rear)</p>	<p><b>69525</b></p>  <p>2P</p> <p>Rear Drive Shafts (91.2mm)</p>	<p><b>69526</b></p>  <p>2P</p> <p>Rear Wheel Shafts</p>
<p><b>69527</b></p>  <p>Motor Guard Set</p>	<p><b>69528</b></p>  <p>2P</p> <p>Front CVD Drive Shafts</p>	<p><b>69529</b></p>  <p>2P</p> <p>Front Upper Linkage Set</p>	<p><b>69530</b></p>  <p>2P</p> <p>Rear Upper Linkage Set</p>
<p><b>69531</b></p>  <p>2P</p> <p>Steering Linkage Set</p>	<p><b>69532</b></p>  <p>Servo Linkage Set</p>	<p><b>69533</b></p>  <p>2P</p> <p>Full Aluminum Oil Filled Shocks (Front)</p>	<p><b>69534</b></p>  <p>2P</p> <p>Full Aluminum Oil Filled Shocks (Rear)</p>
<p><b>69572</b></p>  <p>Front Skid Plate (Aluminum)</p>	<p><b>69536</b></p>  <p>2P</p> <p>Rear Shock Upper Retainer</p>	<p><b>69537</b></p>  <p>2P</p> <p>Diff. Shafts +E-Clip (2mm) (Front/Rear)</p>	<p><b>69538</b></p>  <p>4P</p> <p>Hinge Pins-Lower Outer+E-Clip (2mm) <math>\phi</math> 3*30.9mm</p>

NOTES: THE IMAGES OF THE PARTS MAY VARY FROM YOUR ACTUALLY RECEIVED PARTS.



# LIST FOR REPLACEMENT PARTS

**69539**



4P

Hinge Pins-Lower Inner  
φ 3\*60.3mm

**69540**



Servo Saver Assembly B  
+Ackerman Plate

**69541**



2P

Steering Posts

**69542**



2P

Front/rear / Centre Diff.  
Outdrives

**69543**



2P

Centre Outdrives+  
Set Screws 3\*3-2\*7)

**69544**



8P

Step Ball Stud.  
φ 4.8\*16.6

**69545**



8P

Steering Knuckle  
Bushings

**69546**



8P

Front CVD Shaft Clips

**69547**

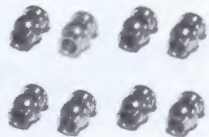

8P

Ball Stud. φ 4.8\*6.8

**69548**



8P

Ball Stud. φ 4.8\*8.5

**69549**

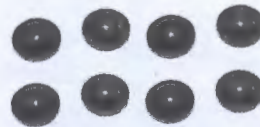

8P

Shock Inner Oil Bowls

**69550**

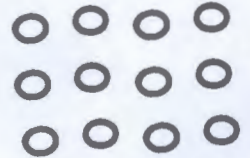

12P

Shock O-ring

**69551**



12P

Washers  
(φ 3.1\*6\*0.5mm)

**69552**



8P

Diff. Paper Washers

**69553**



8P

Steering Plate  
Bushings

**69554**



8P

Flange Ball Bearings  
(3\*6\*2.5mm)

**69555**

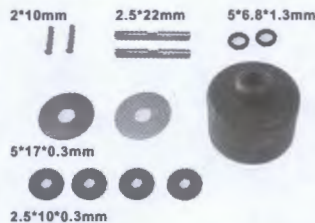

Diff. Pinions+Pins+  
Washers+O-ring+ Diff. Case

**69556**



Front/rear Diff.  
Complete

**69557**



Servo (6Kgs)

**69558**



Brushed Motor



# LIST FOR REPLACEMENT PARTS

<p><b>69559</b></p>  <p>Splash Resistant Brushed ESC ( w/banana plugs)</p>	<p><b>69560</b></p>  <p>Mounting Hole: 5mm (brushless only) Motor Pinion (13T) +Set Screw 4*4</p>	<p><b>69561</b></p>  <p>Mounting Hole: 5mm (brushless only) Motor Pinion (20T) +Set Screw 4*4</p>	<p><b>69562</b></p>  <p>Brushless Motor (KV 2574)</p>
<p><b>69563R</b></p>  <p>Splash Resistant Brushless ESC w/banana plugs</p>	<p><b>69564</b></p>  <p>Light lenses(front/rear) +gear lever</p>	<p><b>69576</b></p>  <p>Body Assembly (Blue)</p>	<p><b>69577</b></p>  <p>Body Assembly (green)</p>
<p><b>69568</b></p>  <p>Li-po Battery 11.1V,30c, 3000MAH (w/banana plug)</p>	<p><b>69573</b></p>  <p>Li-po Battery Charger+ European Standard Plug</p>	<p><b>69574</b></p>  <p>Li-po Battery Charger+ Australia Standard Plug</p>	<p><b>P010</b></p>  <p>Zip Tie (Big) 8P</p>
<p><b>P011</b></p>  <p>Zip Tie (Small) 8P</p>	<p><b>P120</b></p>  <p>Wheel Hex. 4P</p>	<p><b>P019</b></p>  <p>Receiver Antenna Pipe 2P</p>	<p><b>P101</b></p>  <p>Motor Pad 4P</p>
<p><b>H007</b></p>  <p>Ball Bearing 5*11*4 6P</p>	<p><b>H009</b></p>  <p>Ball Bearing 10*15*4 4P</p>	<p><b>H002</b></p>  <p>Lock Nut M3 6P</p>	<p><b>H003</b></p>  <p>Flange Lock Nut M4 6P</p>

NOTES: THE IMAGES OF THE PARTS MAY VARY FROM YOUR ACTUALLY RECEIVED PARTS.



# LIST FOR REPLACEMENT PARTS

<p><b>H013</b></p>  <p>8P</p> <p>Ball Stud. <math>\phi 4.8 \times 11.2</math></p>	<p><b>H022</b></p>  <p>8P</p> <p>Wheel Hex. Pin (2*10mm)</p>	<p><b>H153</b></p>  <p>8P</p> <p>E Clip (2mm)</p>	<p><b>H100</b></p>  <p>Motor Heat Sink</p>
<p><b>6538-H005</b></p>  <p>Diff. Main Gear+ Pinion</p>	<p><b>3338-T010</b></p>  <p>Bevel Gears(Large+ Small) (Front/rear/ Centre)</p>	<p><b>E710</b></p>  <p>Receiver 2.4Ghz</p>	<p><b>69571</b></p>  <p>Cockpit</p>
<p><b>69580</b></p>  <p>12P</p> <p>Plum Blossom Washer Head Self Tapping Screw 3*8mm</p>	<p><b>69581</b></p>  <p>12P</p> <p>Plum Blossom Washer Head Self Tapping Screw 3*10mm</p>	<p><b>69582</b></p>  <p>12P</p> <p>Plum Blossom Washer Head Screw 3*10mm</p>	<p><b>69583</b></p>  <p>12P</p> <p>Plum Blossom Washer Head Self Tapping Screw 3*12mm</p>
<p><b>69584</b></p>  <p>12P</p> <p>Plum Blossom Washer Head Screw 3*12mm</p>	<p><b>69585</b></p>  <p>12P</p> <p>Plum Blossom Washer Head Self Tapping Screw 3*12mm(small head)</p>	<p><b>69586</b></p>  <p>12P</p> <p>Plum Blossom Washer Head Self Tapping Screw 3*14mm</p>	<p><b>69587</b></p>  <p>12P</p> <p>Plum Blossom Washer Head Self Tapping Screw 3*16mm</p>
<p><b>69588</b></p>  <p>12P</p> <p>Plum Blossom Washer Head Self Tapping Screw 3*18mm</p>	<p><b>69589</b></p>  <p>12P</p> <p>Plum Blossom Washer Head Screw 3*14mm</p>	<p><b>69590</b></p>  <p>12P</p> <p>Plum Blossom Washer Head Self Tapping Screw 3*21mm</p>	<p><b>69591</b></p>  <p>12P</p> <p>Plum Blossom Washer Head Self Tapping Screw 3*24mm</p>

NOTES: THE IMAGES OF THE PARTS MAY VARY FROM YOUR ACTUALLY RECEIVED PARTS.











# LIST FOR REPLACEMENT PARTS

<p><b>69592</b></p>  <p>12P</p> <p>Plum Blossom Washer Head Self Tapping Screw 3*37mm</p>	<p><b>69593</b></p>  <p>12P</p> <p>Plum Blossom Washer Head Self Tapping Screw 2.6*12mm</p>	<p><b>69594</b></p>  <p>12P</p> <p>Plum Blossom Washer Head Self Tapping Screw 2.3*14mm</p>	<p><b>69595</b></p>  <p>12P</p> <p>Plum Blossom Washer Head Self Tapping Screw 2.3*8mm</p>
<p><b>69596</b></p>  <p>12P</p> <p>Plum Blossom Washer Head Screw 2.5*17mm</p>	<p><b>69597</b></p>  <p>12P</p> <p>Plum Blossom Washer Head Screw 2.5*14mm</p>	<p><b>69598</b></p>  <p>12P</p> <p>Plum Blossom Washer Head Self Tapping Screw 2.3*14mm</p>	<p><b>69599</b></p>  <p>12P</p> <p>Plum Blossom Washer Head Self Tapping Screw 2.3*8mm</p>
<p><b>69600</b></p>  <p>12P</p> <p>Plum Blossom Countersunk Self Tapping Screw 3*10mm</p>	<p><b>69601</b></p>  <p>12P</p> <p>Plum Blossom Countersunk Self Tapping Screw 3*12mm</p>	<p><b>69602</b></p>  <p>12P</p> <p>Plum Blossom Countersunk Self Tapping Screw 3*12mm</p>	<p><b>69603</b></p>  <p>12P</p> <p>Plum Blossom Countersunk Self Tapping Screw 2.3*12mm</p>
<p><b>69604</b></p>  <p>12P</p> <p>Plum Blossom Countersunk Self Tapping Screw 3*14mm</p>	<p><b>69605</b></p>  <p>12P</p> <p>Plum Blossom Countersunk Self Tapping Screw 2.3*7mm</p>	<p><b>69606</b></p>  <p>12P</p> <p>Washer Head Screw 3*45mm</p>	<p><b>69607</b></p>  <p>12P</p> <p>Cap Head Hex. Screw 3*10mm</p>
<p><b>69608</b></p>  <p>12P</p> <p>Cap Head Self Tapping Hex. Screw 1.5*4mm</p>	<p><b>69609</b></p>  <p>12P</p> <p>Cap Head Hex. Screw 2*8mm</p>	<p><b>69610</b></p>  <p>12P</p> <p>Washer Head Self Tapping Screw 2*6mm</p>	<p><b>69611</b></p>  <p>12P</p> <p>Set Screw 4*4mm</p>

NOTES: THE IMAGES OF THE PARTS MAY VARY FROM YOUR ACTUALLY RECEIVED PARTS.

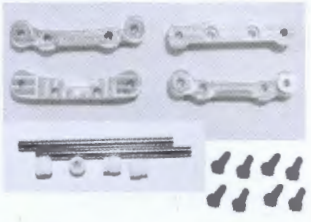

# LIST FOR REPLACEMENT PARTS

<p><b>S015</b></p>  <p>12P</p> <p>Step Set Screw 3*3-2*7</p>	<p><b>S016</b></p>  <p>12P</p> <p>Set Screw 3*3mm</p>	<p><b>S018</b></p>  <p>12P</p> <p>Washer Head Self Tapping Screw 2.6*8mm</p>	<p><b>S038</b></p>  <p>12P</p> <p>Countersunk Self Tapping Screw 2*9mm</p>
<p><b>S089</b></p>  <p>12P</p> <p>Washer Head Self Tapping Screw 2.6*6mm</p>	<p><b>S154</b></p>  <p>12P</p> <p>Washer Head Hex. Screw 3*18mm</p>	<p><b>69575</b></p>  <p>Aluminum Suspension Mount Assembly</p>	
<p><b>69569</b></p>  <p>Li-po Battery Charger+ American Standard Plug</p>	<p><b>69578</b></p>  <p>Li-po Battery Charger+ UK Standard Plug</p>		

NOTES: THE IMAGES OF THE PARTS MAY VARY FROM YOUR ACTUALLY RECEIVED PARTS.







# UNITS ASSEMBLY-2

## CENTRE DIFF. ASSEMBLY

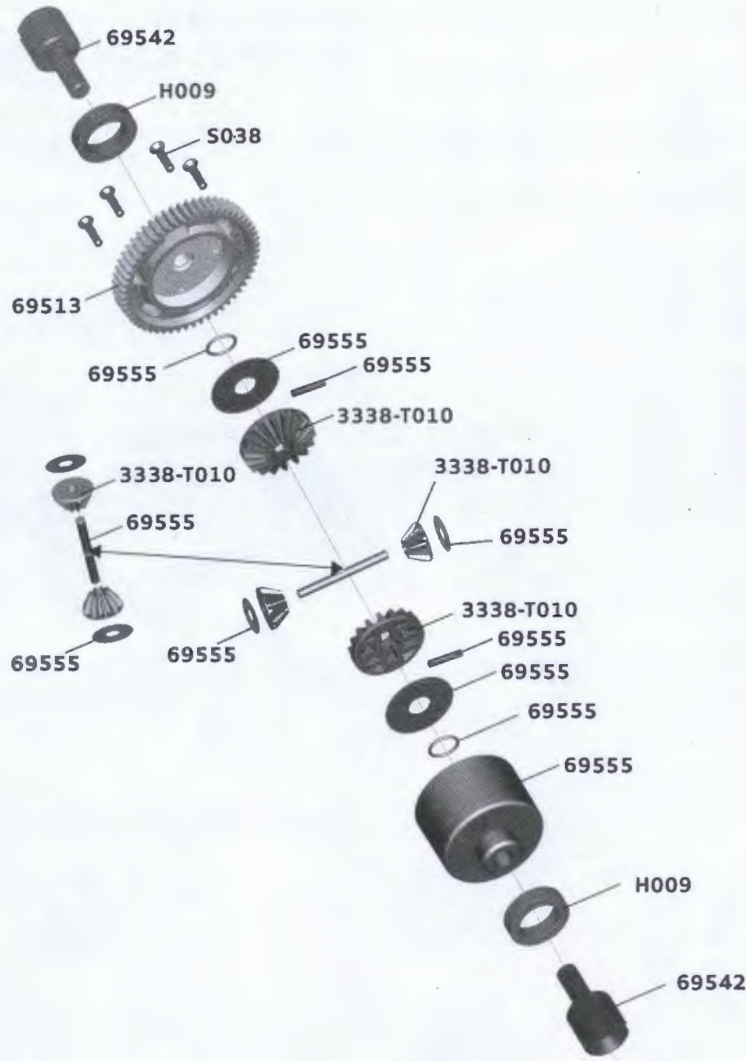

FINISHED



## CENTRE UNIT/MOTOR ASSEMBLY

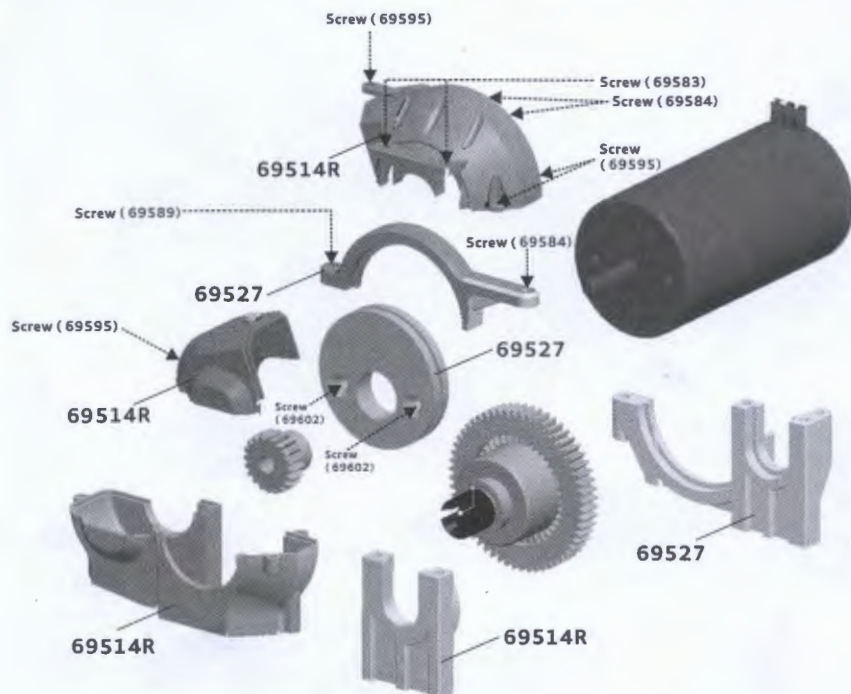

FINISHED



NOTES: THE IMAGES OF THE PARTS MAY VARY FROM YOUR ACTUALLY RECEIVED PARTS.







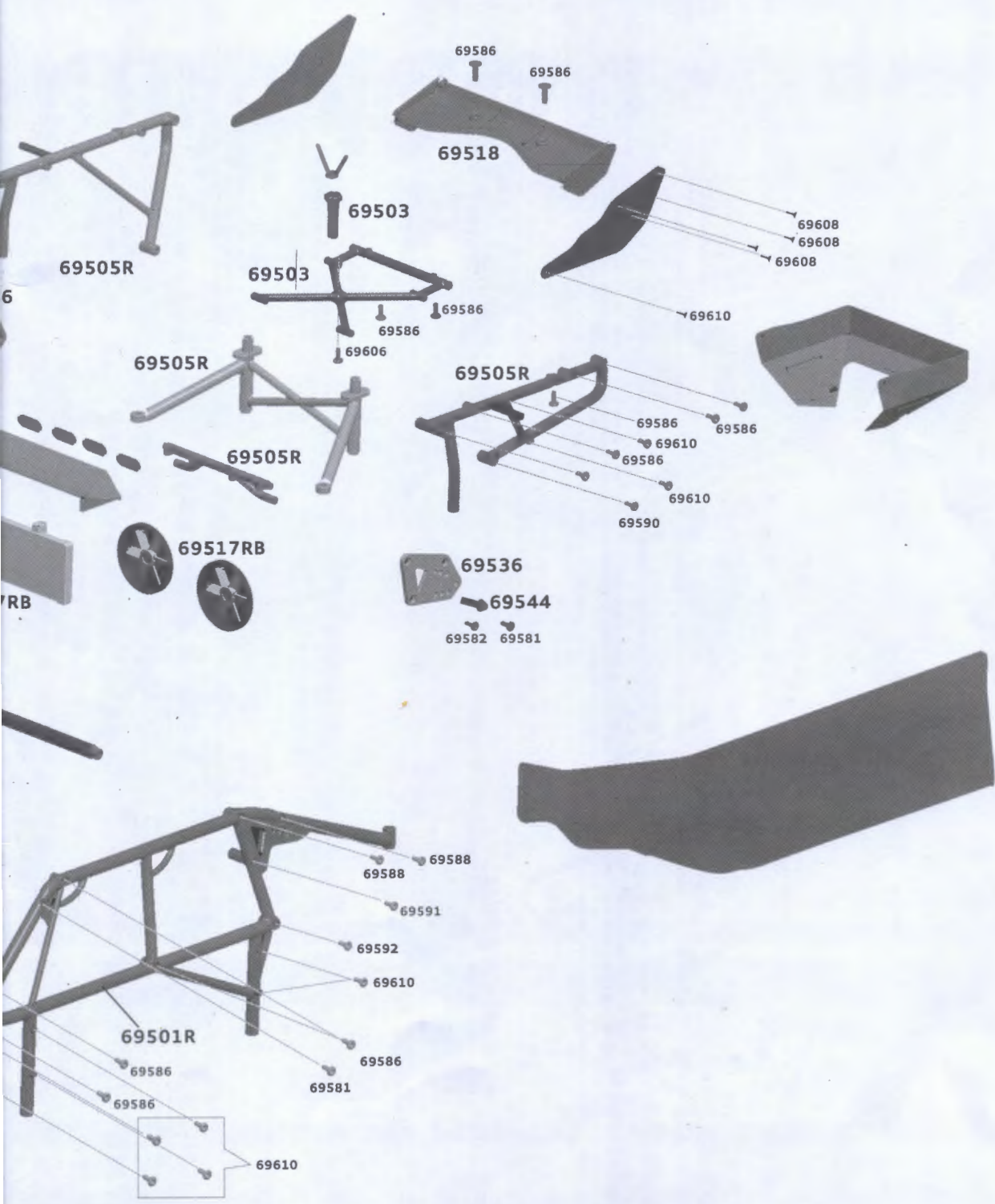

GY

L

0

p

ger







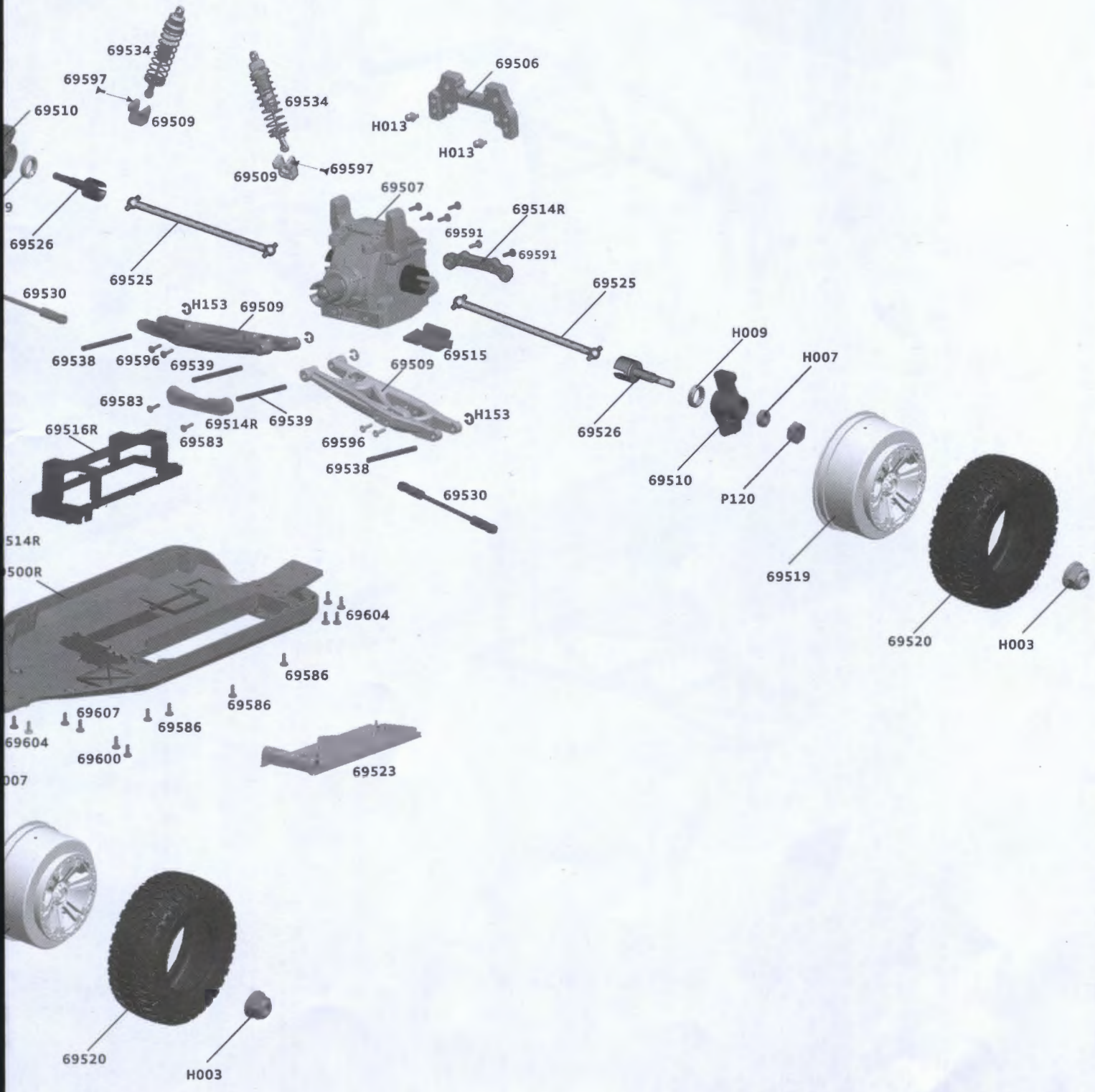



This product is not a toy. It is not suitable for users under 14 years old unless supervised by an adult. Never attempt to re-assemble any electronic components. These have been carefully calibrated at the factory.



## 1/8TH SCALE ELECTRIC POWERED 4WD SAND RAIL BUGGY

### WARNINGS

- Read and understand all instructions carefully before use and assembly/disassembly.
- Do not run your vehicle on public roads or any area where you may encounter pedestrian or vehicle traffic.
- Do not operate in a congested area or in crowds.
- Do not operate your vehicle with obstructed line of sight, at night, or near water.
- Your vehicle is radio controlled. Radio waves are subject to interference. Radio interference can cause loss of control of your vehicle.
- Take care not to injure yourself while using tools to adjust or upgrade your vehicle.