

Since 1968

COMMAX
SmartHome & Security

User Manual

Color video door phone CDV-35U



www.commax.com

COMMAX Co.,Ltd.



- Thank you for purchasing COMMAX products.
- Please carefully read this User's Guide (in particular, precautions for safety) before using a product and follow instructions to use a product exactly.
- The company is not responsible for any safety accidents caused by abnormal operation of the product.



Table of contents

1. Greetings	1
2. Warnings and caution	2
3. Parts and function	4
4. How to use this product	5
5. Initialization (RESET)	8
6. How to install	9
7. Wiring	10
8. Parts list	12
9. Miscellaneous	12
10. Specification	13



1. Greetings

- Thank you for choosing COMMAX.
- Please read this manual carefully before you use the product.



2. Warnings and caution

Please follow the things described below in order to prevent any danger or property damage.

	Warning	It may cause a serious damage or injury if violated.		Prohibition.
	Caution	It may cause a minor damage or injury if violated.		No disassembly
				No touch
				Must follow strictly.
				Shows plugging out the power cord without an exception
				Shows the warning and caution for an electric shock.
				Shows the warning and caution for a fire.

Warning

Power & Installation

Please don't use several products at the same time on one power socket.

- It may cause a fire due to an abnormal overheating.

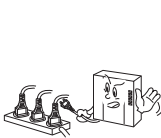

Please don't bend the power cable excessively or it may cause an electric shock.

- fire when using a damaged power cable.

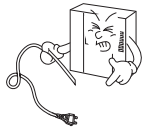

Please don't handle the power cable with a wet hand.

- It may cause an electric shock.

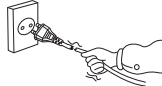

Please plug out the power cable from the socket when not using it for a long period of time.

- It may shorten the product lifespan or cause a fire.



Please don't install the product in the place where there is much oil, smoke or humidity.

- It may cause an electric shock or fire.

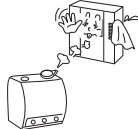

Please don't install the product with the lightning and thunder.

- It may cause an electric shock or fire.

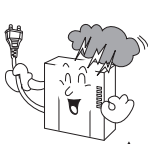

Please don't use and connect this product with other products with different rated voltage.

- It may cause a disorder or fire.



When installing the product that generates heat, please install the product away from the wall (10cm) for the ventilation.

- It may cause a fire due to the increased internal temperature.

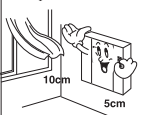

⚠ Warning

Cleaning & Use

Please don't disassemble, repair or rebuild this product arbitrarily (please contact the service center if a repair is needed).

- It may cause an electric shock or fire.



If an abnormal sound, burning smell or smoke is coming out of the product, please plug out the power cable and contact a service center.

- It may cause an electric shock or fire.



Please don't insert any metallic or burnable materials into the ventilation hole.

- It may cause an electric shock or fire.

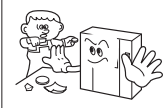

Please use only the designated batteries for the products of using DC power.

- It may cause an electric shock or fire.

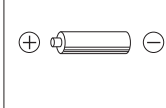

⚠ Caution

Power & Installation

Please plug the power cable firmly into the inner end

- It may cause a fire.

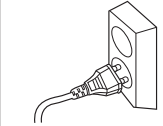

Please hold the plug tightly when unplugging the power cable (a part of the copper wire may be disconnected if the grabbing is only made on the cord when pulling out the cable).

- It may cause an electric shock or fire.

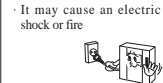

When connecting the power cables after cutting the cable, please install the product with power off

- It may cause an electric shock or fire.

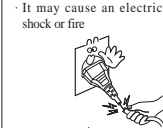

When installing the product, please fix it firmly while using the wall-mounting unit and screws.

- It may cause an injury from the falling object.



Please be careful when using an AC circuit breaker since there is a possibility of an electric shock.



Please check the use voltage and current for the DC-only products and use the appropriate rectifier.

- It may cause a fire.



Please avoid direct rays of the sun or heating devices at a time of installation.

- It may cause a fire.



Please don't install the product on an unstable place or small support board.

- It may cause an injury if it falls down while in use.



Cleaning & Use

When cleaning the product, please rub it with a soft and dry cloth after plugging out the power cable. (Please don't use any chemical products such as wax, benzene, alcohol or cleanser.)



Please don't drop the product on the ground and don't apply a shock.

- It may cause a failure.

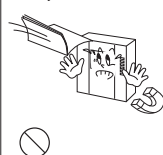

Please use the designated connection cable within the maximum calling distance designated for the product

- It may reduce the product performance.





3. Parts and function

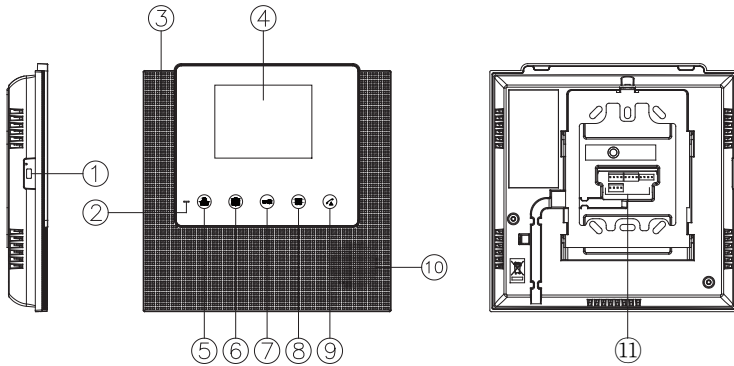

NO.	Name	NO.	Name
1	POWER SWITCH	7	DOOR RELEASE BUTTON/UP BUTTON
2	POWER AND DISPLAY LED	8	MENU BUTTON
3	MICROPHONE	9	TALK BUTTON
4	LCD MONITOR	10	SPEAKER
5	MONITOR BUTTON	11	CONNECTION TERMINAL
6	INTERPHONE BUTTON / DOWN BUTTON		

1. POWER SWITCH : ON/OFF switch
2. POWER AND DISPLAY LED
: blue in power on mode and light-out in power off mode.
3. MICROPHONE
4. LCD MONITOR
5. MONITOR BUTTON(ENTRANCE) : to check the situation of entrance.
6. INTERPHONE button: to call the interphone.
(UP BUTTON : to level up in the menu)
7. DOOR RELEASE BUTTON: to release the door for visitor.
(DOWN BUTTON : to level down in the menu)
8. MENU BUTTON : to enter or exit the menu for screen control, call sound and receiver volume
9. TALK BUTTON : to answer for visitor.
10. SPEAKER

11. TERMINAL FOR EXTERIOR : terminal for product upgrade, entrance camera and interphone connection.



4. How to use this product

1. Call from the visitor

- ① When the visitor calls from the entrance(door camera), the calling sound rings and the image of the visitor is shown on the screen.
- ② If you press the talk button, you can talk with door camera. By pressing the door release button, door will be released. (Door release works only while talking.)
(Please note that this function is possible only when the door camera is interlocked with door release function.)
- ③ 3-way communication is possible when another user picks up the handset of extended interphone, when you are talking with door camera on video door phone.
(Entrance-Household -Interphone simultaneous communication mode)
- ④ If you press the talk button, again talking is finished and video door phone turns to stand-by mode. (You can install additional camera. In case of receiving call from camera 1, blue LED blinks. In case of receiving call from camera 2, purple LED blinks.)

2. Call with additional interphone

2-1. Call between door camera and interphone

- ① When the visitor calls from the door camera, calling sound rings on interphone and video door phone.
- ② By picking up the handset of interphone, you can talk with door camera. By pressing the door release button, door will be released.

2-2. Talk between interphone and video door phone(household).

- (1) In case of receiving the call of household phone from interphone
- ① In order to call the household from interphone, pick up the interphone handset and press call button. Then, video phone will be ringing.
 - ② You can talk with interphone by pressing the call button of household or interphone button.

- ③ 3-way communication is possible between household, interphone and door camera when visitor calls from door camera, while household is talking with interphone. Image from door camera is displayed on the screen of household with calling sound and 3-way communication gets available.
 - ④ If you press the interphone button or talk button after ending the call
- (2) In case of calling interphone from household
- ① Press Talk Button and Interphone Button in order to call the interphone.
(Interphone is called only while the interphone button on household is being pressed.)
 - ② When you receive the call from interphone, enjoy the call.

3. Monitoring : function to see the image of visitor in the entrance.

(On stand-by mode) Operation

- By pressing the Monitor button repeatedly, the monitor will work as following in order.

Camera 1 → (Camera 2) → OFF → Camera 1 →

(On talking mode) Operation

- By pressing the Monitor button repeatedly, the monitor will work as following in order.

Camera 1 → Camera 2 → Camera 1 → Camera 2 →

[Caution : If you use only 1 camera, press monitor button while talking, the call with entrance will be ended.]

4. Volume control (ringing sound/receiver sound)

(1) Call volume control : adjustable on stand-by status.

- ① Press the menu button one time on stand-by status.
- ② Red LED will be turned on(lighting) : call volume control mode.
- ③ Adjust it with UP(door release) / DOWN(interphone) button.
(Ringing sound of new size will ring one time when controlling by pressing control button in order to check the volume)

(2) Receiver volume control : adjustable while talking

- ① Press the menu button one time while talking.
- ② Red LED will be turned on(lighting) : receiver volume control mode
- ③ Adjust it with UP(door release) / DOWN(interphone) button

- Volume of ringing sound and receiver sound consists of 3 steps and you cannot change it any more despite pressing UP/DOWN button with certain sound (beep beep sound)in Max/Min status.

5. Image setting_ BRIGHT / CONT / COLOR adjustment (available when the screen is on)

- The image setting mode will be sequentially operated when user presses the menu button as follows.
 - Calling : BRIGHT → CONTRAST → COLOR → RETURN → BRIGHT → ...
 - Talking : Receiver sound adjustment → BRIGHT → CONTRAST → COLOR → RETURN → Receiver sound adjustment → BRIGHT → ...

5-1. BRIGHT brightness adjustment

- Press the menu button once when the image is on.
(LED lamp will be changed from blue to red.)
Red LED blinks fast. [●○●○●○●○]
- You are in brightness adjustment mode.
- Press the UP(Door release) / DOWN(Interphone) button in front of the product in order to adjust the brightness.
- After completing the set, save the revised setting value by pressing the menu button.
(LED lamp will be changed from red to blue.)

5-2. CONTRAST contrast adjustment

- Press the menu button twice when the image is on. (While talking: 3 times)
(LED lamp will be changed from blue to red.)
Red LED blinks slowly. [●●○○●●○○●●○○●●○○]
- You are in CONTRAST adjustment mode.
- Press the UP(Door release) / DOWN(Interphone) button in front of the product in order to adjust the CONTRAST.
- After completing the set, save the revised setting value by pressing the menu button.
(LED lamp will be changed from red to blue.)

5-3. COLOR color adjustment

- Press the menu button three times in the state of the image on. (while talking 4 times)
(LED lamp will be changed from blue to red.)
Red LED blinks very slowly. [●●●○○○●●●○○○●●●○○○●●●○○○] 7

- You are in COLOR adjustment mode.
- Press the UP(Door release button) / DOWN(Interphone button) button in front of the product in order to adjust the condition of the COLOR.
- After completing the set, save the revised setting value by pressing the menu button.
(LED lamp will be changed from red to blue.)

Reference : if you press the menu button, menu mode will work as follows.

Stand-by : Ringing sound adjustment → return → Ringing sound adjustment → ...

Calling : BRIGHT → CONTRAST → COLOR → return → BRIGHT → ...

Talking : Receiver sound adjustment → BRIGHT → CONTRAST → COLOR → return →
Receiver sound adjustment → ...

● Menu according to LED condition.

1. Ringing sound adjustment(stand-by) : red LED lighting (on)
2. Receiver sound adjustment(talking) : red LED lighting (on)
3. Image brightness adjustment(image-monitoring/call) : red LED flickering (blinking at a fast pace)
4. Image contrast adjustment(image-monitoring/call) : red LED flickering (blinking at a normal pace)
5. Image color adjustment(image-monitoring/call) : red LED flickering (blinking at a slow pace)

[Caution : menu will be over if there's no key input for 5 seconds with toot toot sound in the state of menu.]



5. Initialization (RESET)

- Press the interphone button and door release button at the same time for about 3 seconds.
Then, image setting value and sound volume will be initialized.



6. How to install

1. Installation Method of Video Door Phone

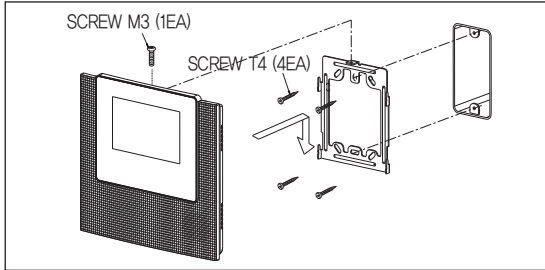

Note

- ① Avoid the range of direct sunlight
- ② Recommended height is pertinent from 1450 ~ 1500mm
- ③ Avoid the installation near magnetic activity, humid temperatures and gas

2. Installation Method of Camera

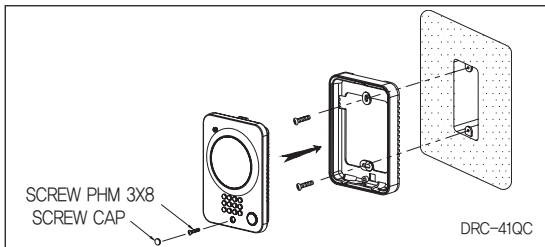

Note

- ① Do not install the camera where it is exposed to Direct sunlight
- ② Keep cleaning up its lens to capture good views.

7. Wiring

Camera connector polarity

The wiring of this equipment is as follows,

1. Red : Voice 2. Blue : GND 3. Yellow : DC 12V 4. White : Video

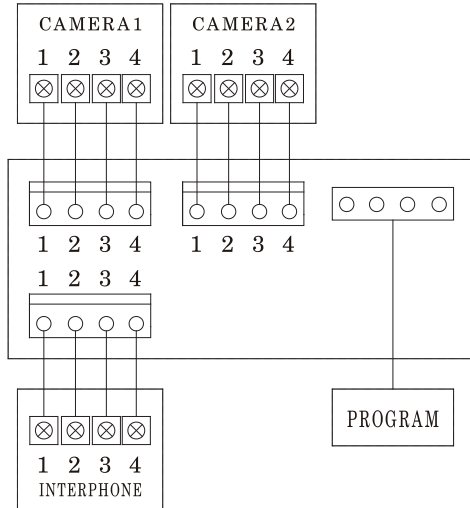

* When using UTP CABLE[CAT.5] for better image quality, connect the rest 4 lines to GND after connecting 4 lines with monitor and camera.

Wiring precautions

- Each device should be connected by separated cables.
To use CAMERA 1, CAMERA 2 and interphone using UTP CABLE[CAT.5], 3 lines of UTP cable are required.

DOOR Camera wiring

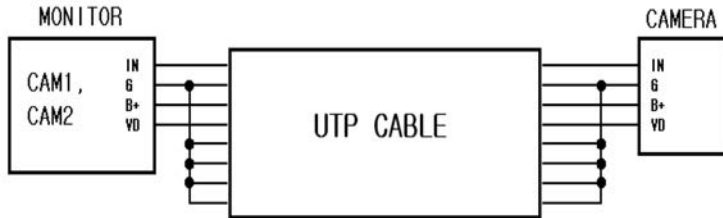

- When using UTP CABLE[CAT.5] for better image quality, connect the rest 4 lines to GND after connecting 4 lines with monitor and camera.

DOOR Camera wiring

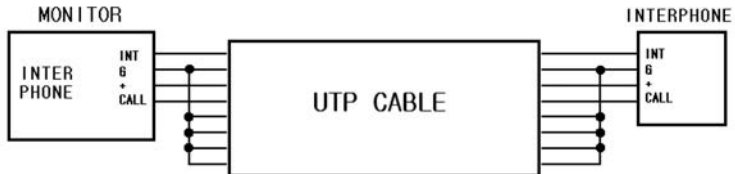

- When using UTP CABLE[CAT.5] for better image quality, connect the rest 4 lines to GND after connecting 4 lines with monitor and interphone.



8. Parts list

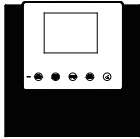

① Body of CDV-35U

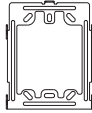

② Bracket for wall mount



③ Manual



④ T4 X 18(4EA)
Screw for wall mount



⑤ M3 x 6(1EA)
Screw for body



⑥ 4P Connector(2EA)



- ① Main body(CDV-35U)
- ② Bracket for wall surface mounting
- ③ User Manual
- ④ Screw for wall bracket (SCREW GH1T 4X18 ZnY) - 4EA
- ⑤ Screw for body (SCREW PHM 3X6 ZnY) - 1EA
- ⑥ Camera connector (CONN. 4PX300) - 2EA



9. Miscellaneous

- Please carefully read this User Manual before calling service
After checking the entire list, please contact customer service center.
We will do our best to make you satisfy with our services.

COMMAX

COMMAX Co.,Ltd.

513-11, Sangdaewon-dong, Jungwon-gu, Seongnam-si, Gyeonggi-do, Korea

Int'l Business Dept. Tel. : +82-31-7393-540~550 Fax. : +82-31-745-2133

Web site : www.commax.com

PM0735U00010

Printed In Korea / 2012.05.104



10. Specification

Spec	Model	CDV-35U
Rating Voltage		100-240V~, 50/60Hz (FREE VOLTAGE)
Consumption		Operation: 10W(MAX)
Transmission		Entrance 4wires polarity, interphone 4wires polarity
Screen size		3.5" TFT-DIGITAL LCD
Call mode		HANDS FREE Call mode (Voice switch circuit)
Ringing sound		Entrance : electronic chime,
		Interphone : electronic buzzer
Screen Display		60 ±10sec (During conversation)
		30 ±10sec (During monitoring)
Distance(Cable thickness)		28m(∅ 0.5) / 50m(∅ 0.65) / 70m(∅ 0.8)
Working temperature		0 ~ +40°C (32°F ~ 104°F)
Dimension		180.0(W)X180.0(H)X28.5(D)