



This Datasheet for the

[IC697CMM742](#)

Ethernet Interface for Series 90-70, Type 2.

<http://www.cimtecautomation.com/parts/p-14777-ic697cmm742.aspx>

Provides the wiring diagrams and installation guidelines for this GE Series 90-30 module.

For further information, please contact Cimtec Technical Support at

1-866-599-6507

sales@cimtecautomation.com

GFK-1309E
September 1998

Ethernet Interface (Type 2)

a45632

Features

- Connects IC697 PLC to an IEEE 802.3 CSMA/CD 10Mbps Ethernet LAN via one of three network ports: 10BaseT, 10Base2, or AUI
- 10BaseT and 10Base2 network ports provide direct connection to 10BaseT or 10Base2 network without an external transceiver
- Standard 15-pin AUI network port allows choice of 10Base5, 10Base2, 10BaseT, 10BaseF, or 10Broad36 medium with user-supplied 802.3-compatible transceiver
- Firmware is pre-loaded for easy installation and is maintained indefinitely; firmware is easily upgraded in-system from PC attached to RS-485 serial port
- The Ethernet Interface provides:
 - Data exchange using configuration-based and logic-based Ethernet Global Data
 - TCP/IP communications services using SRTP
 - Full PLC programming and configuration services
 - Comprehensive station management and diagnostic tools

Functions

The IC697CMM742 Ethernet Interface (Type 2) provides high performance TCP/IP communications for the IC697 PLC.

The Ethernet Interface (Type 2) plugs into a single slot in an IC697 PLC rack and is configured with the IC641 PLC programming software. Up to four Ethernet Interface (Type 2) modules can be installed in an IC697 PLC CPU rack.

The Ethernet Interface (Type 2) contains three network ports: 10BaseT (RJ-45 connector), 10Base2 (BNC connector), and AUI (15-pin D-connector). The Ethernet Interface automatically selects the network port in use. One network port may be used at a time.

The 10BaseT network port permits direct connection to a 10BaseT (twisted pair) network hub or repeater without an external transceiver.

The 10Base2 network port permits direct connection to a 10Base2 (ThinWire™) network without an external transceiver.

The AUI network port permits attachment of a user-supplied AUI (Attachment Unit Interface, or transceiver) cable.

™ ThinWire is a trademark of Digital Equipment Corporation.

© MS-DOS, Windows, Windows95, and Windows NT are registered trademarks of Microsoft Corporation.

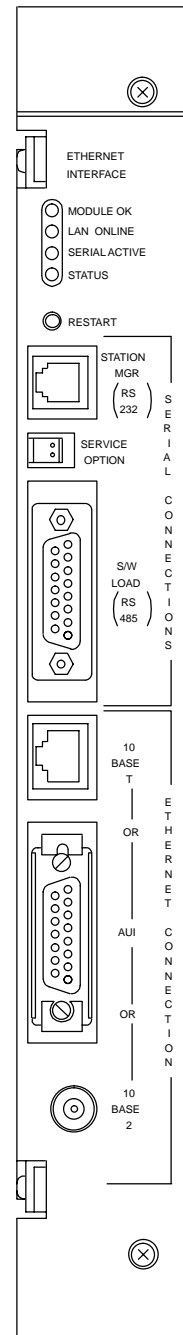

The AUI cable connects the Ethernet Interface to a user-supplied transceiver that is directly connected to the 10Mbps Ethernet network. The transceiver must be 802.3 compatible and must have the SQE option enabled.

GFK-1309E
September 1998

Ethernet Interface (Type 2)

Transceivers are commercially available to operate on a variety of 10Mbps media including 0.4 inch diameter coaxial cable (10Base5), ThinWire coaxial cable (10Base2), twisted pair (10BaseT), fiber optic (10BaseF), and broadband cable (10Broad36).

The Ethernet Interface (Type 2) provides TCP/IP communications with other IC697 and IC693 PLCs, host computers running the Host Communications Toolkit or

CIMPLICITY® software, and computers running the TCP/IP version of the MS-DOS or Windows based programming software. These communications use the proprietary SRTP and Ethernet Global Data protocols over a 4-layer TCP/IP (Internet) stack.

Figure 1 shows the IC697 PLC in a basic Ethernet communication system.

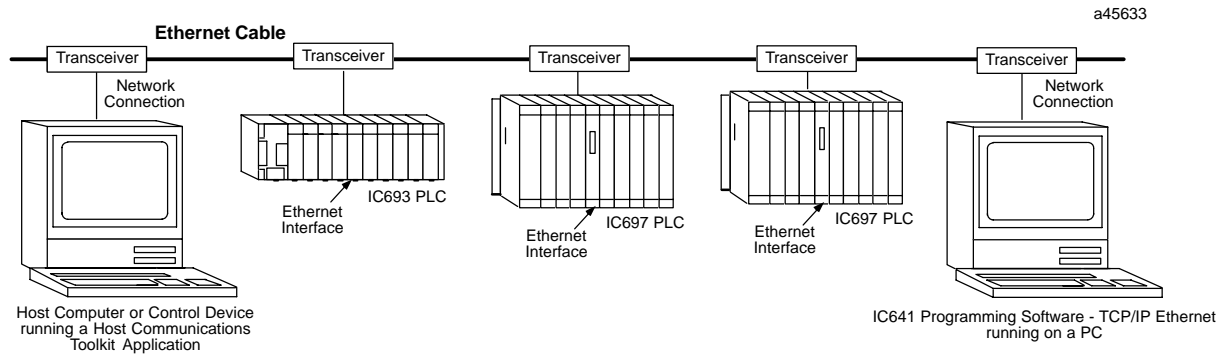

Figure 1. Ethernet Interface Connects the IC697 PLC to an 802.3 LAN

IEEE 802.3 Media

The Ethernet Interface (Type 2) can operate directly on 10BaseT or 10Base2 media via its 10baseT and 10Base2 network ports. These media are described below. Additionally, the Ethernet Interface (Type 2) can operate on any of the media listed below with the appropriate user-supplied transceiver and transceiver cable via its AUI network port.

10Base5 Coax: 10Base5 uses a 0.4 inch diameter 50-ohm coaxial cable. The maximum length of a cable segment (single span of cable) is 500 meters. The distance between any two stations must be a multiple of 2.5 meters. A maximum of 100 stations is allowed on a thickwire Ethernet segment.

10Base2 Coax: 10Base2 uses a 0.2 inch diameter 50-ohm coaxial cable. The maximum length of a ThinWire cable segment is 185 meters. A maximum of 30 stations is allowed on a ThinWire Ethernet segment.

10BaseT: 10BaseT uses a twisted pair cable of up to 100 meters in length between each node and a hub or repeater. Typical hubs or repeaters support 6 to 12 nodes connected in a star wiring topology.

10BaseF: 10BaseF has two variations that both use the same type of fiber optic cable: 10BaseFP can support up

to 33 nodes at distances of up to 500 meters from a passive star; 10BaseFL supports up to 2000 meters between a node and a repeater (a multi-port repeater would thus constitute a star). Additionally, 10BaseFB provides a means of interconnecting (only) repeaters by up to 2000 meters of (the same) fiber optic cable.

Note

Various Ethernet baseband media listed above can be interconnected by appropriate repeaters. Capabilities and limitations are defined in IEEE 802.3 Chapter 13, *System Considerations for Multi-Segment Networks*.

10Broad36: 10Broad36 uses 75-ohm coaxial cable and CATV-like media components (taps, amplifiers, headend translators, etc.) to support hundreds of nodes at distances of up to 2800 meters. Broadband cannot be connected to baseband via repeaters. Broadband cable plant design and installation must be in accordance with IEEE 802.7 and requires special expertise. GE Fanuc recommends you contract professional specialists for these services. Consult your local authorized GE Fanuc PLC distributor, or your GE Fanuc sales representative or field service office for help in identifying local specialists.

Ethernet Interface (Type 2)

GFK-1309E
September 1998

Physical Description

Figure 2 shows the maintenance items and indicators of the Ethernet Interface (Type 2).

a45634

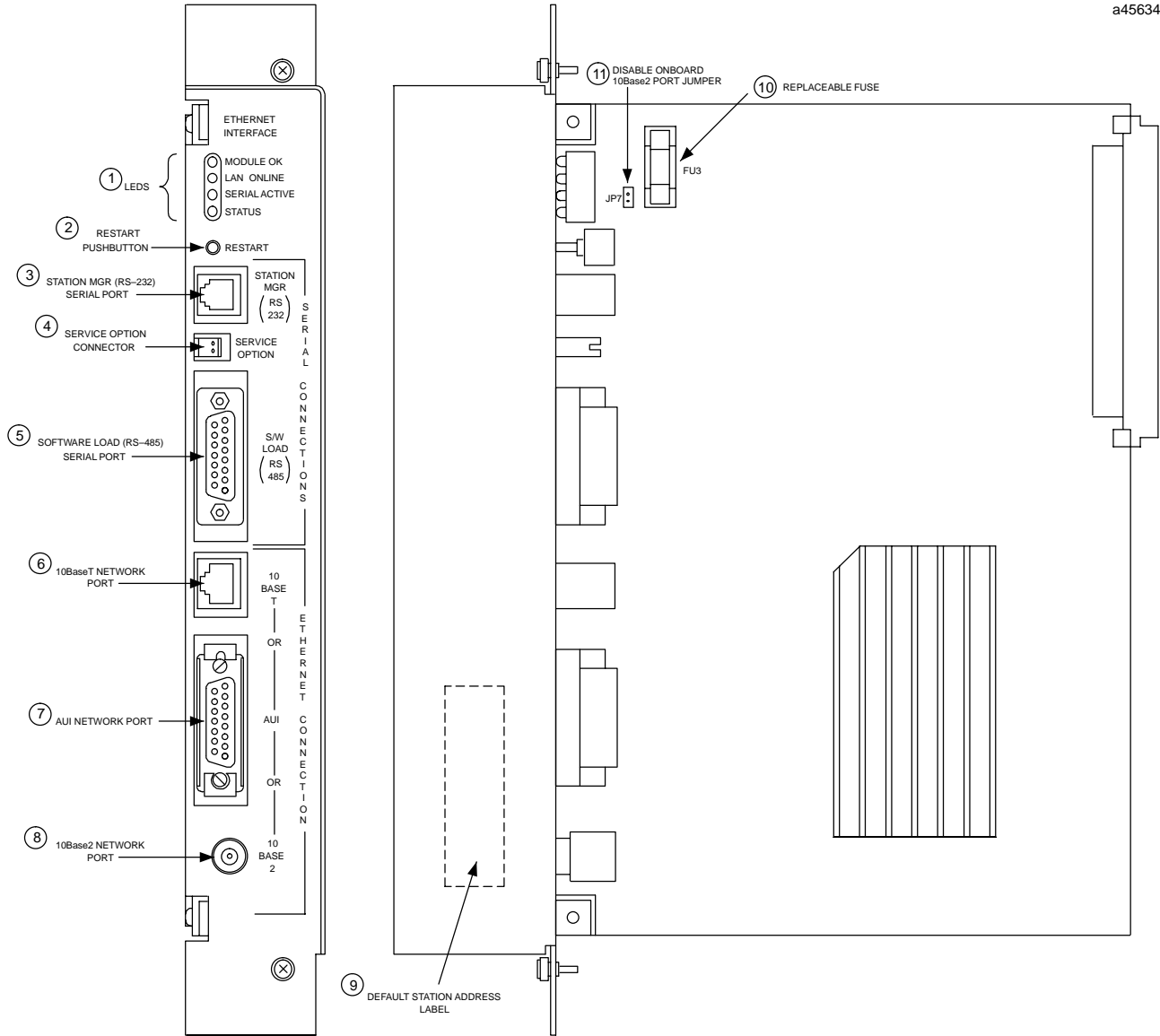

Figure 2. Ethernet Controller Board

User Maintenance Items

The Ethernet Interface has the following user-accessible elements:

1. Four LEDs
2. Restart Pushbutton
3. Station Mgr (RS-232) Serial Port
4. Service Option Connector
5. Software Load (RS-485) Serial Port
6. 10BaseT Network Port
7. AUI Network Port
8. 10Base2 network Port
9. Default Station (MAC) Address Label (located on the inside edge of the module faceplate)
10. Replaceable +12 VDC Fuse (FU3)
11. Onboard 10base2 Transceiver Power Disable Jumper (JP7 - normally not installed)

GFK-1309E
September 1998

Ethernet Interface (Type 2)

Module Indicators

The Ethernet Interface board indicators consist of four Light Emitting Diodes (LEDs):

- MODULE OK
 - LAN ONLINE
 - SERIAL ACTIVE
 - STATUS
- Refer to Figure 2 for the location of the LED indicators, and Table 1 for a description of the indicators.

Table 1. Ethernet Interface (Type 2) LED Indicators

Indicator	Status	Description
MODULE OK	ON	This LED is <i>ON</i> if the Ethernet Interface has passed diagnostics and is operating properly.
	OFF	This LED is <i>OFF</i> if the module fails a diagnostic test, or if a fatal failure is detected during operation.
	BLINKING	This LED is <i>BLINKING</i> during diagnostics, or to indicate special operating conditions. *
LAN ONLINE	ON	This LED is <i>ON</i> when the Ethernet Interface is connected to the Ethernet network and is ready to communicate.
	OFF	This LED is <i>OFF</i> when: - the Ethernet Interface is not communicating in the network due to disconnection or disruption of the cable. - the Ethernet Interface has malfunctioned. - the Ethernet Interface has been commanded not to enter the network.
	BLINKING	This LED is <i>BLINKING</i> when the Ethernet Interface is transferring data on the network or, to indicate special operating conditions. *
SERIAL ACTIVE	OFF	This LED is <i>OFF</i> during inactivity at the RS-485 serial port.
	BLINKING	This LED is <i>BLINKING</i> during data transfer at the RS-485 serial port, or to indicate special operation conditions. *
STATUS OK	ON	This LED is <i>ON</i> when the module is operating without exception conditions.
	OFF	This LED is <i>OFF</i> if the Ethernet Interface detects an event (exception condition) during operation that requires supervisory attention. In this case, refer to the PLC Fault Table for further information, as described in the <i>Troubleshooting</i> chapter of the User's manual.
	BLINKING	This LED is <i>BLINKING</i> during special operating conditions. *

*Special operating conditions are indicated by multiple LEDs blinking in unison:

- During the *Software Load* state, all LEDs blink in unison.
- During the *Waiting for IP Address* state, the MODULE OK and STATUS LEDs blink in unison.
- During the *Maintenance* state, the MODULE OK and SERIAL ACTIVE LEDs blink in unison.

Restart Pushbutton

The Restart button serves four functions: LED test, restart, restart and enter Software Load state, and restart and enter Maintenance state. These four functions behave similarly in all states except for the Software Load state. While in this state, pressing the pushbutton will cause an immediate restart into the Operational state (without performing the LED test) if the software in the Ethernet Interface has not been corrupted or erased. If the software has been corrupted or erased, pressing the pushbutton will cause an immediate restart back into the Software

Load state. Use a pointed tool to press the Restart pushbutton.

LED Test: Any time the Restart pushbutton is released *all* the LEDs flash ON. You should visually verify that all the LEDs go OFF and ON at this time. Then the Interface performs either a restart, a restart and enter Software Load state, or a restart and enter Maintenance state, depending on the duration that you press the pushbutton.

Restart: Pressing the Restart pushbutton momentarily (less than 5 seconds) requests a restart of the Ethernet Interface. When the Restart pushbutton

Ethernet Interface (Type 2)

GFK-1309E
September 1998

is pressed, all LEDs go out. When it is released, all LEDs flash ON, then power-up diagnostics run, and the software on the Interface is restarted into the Operational state.

Restart and Enter Software Load State: Pressing and holding the Restart pushbutton until the bottom LED (STATUS) turns ON (between 5 and 10 seconds) forces a restart and requests entrance to the Software Load state. A reload is used to install a software update into the module and is not part of normal operation. When the Restart pushbutton is pressed, all LEDs go out. After approximately 5 seconds have elapsed, the STATUS LED (bottom LED) comes ON, to indicate that the Ethernet Interface will request a reload. After the Restart pushbutton is released, all LEDs flash ON, then power-up diagnostics run, and the Ethernet Interface waits for the software load with all LED's blinking in unison.

Restart and Enter Maintenance State: Pressing and holding the Restart pushbutton until the bottom two LEDs turn ON (approximately 10 seconds) forces a restart and requests entrance to the Maintenance state. After approximately 5 seconds, the STATUS LED comes ON, then after approximately a total of 10 seconds have elapsed, the SERIAL ACTIVE LED also comes ON, to indicate that the Ethernet Interface will request entry to the Maintenance state. After the Restart pushbutton is released, all LEDs flash ON, power-up diagnostics run and the Ethernet Interface enters the Maintenance state.

Note

Any data being transferred by the Ethernet Interface at the time of the Restart will be lost.

The Restart pushbutton is not operable during the diagnostic phase of power-up. The Ethernet Interface is in the diagnostic phase when the MODULE OK LED is BLINKING and the other LEDs are OFF.

Service Option Connector

If a problem occurs with the Ethernet Interface that requires removal from the PLC rack, the onboard exception log will be preserved for 2 to 3 days. The Service Option connector allows you to attach a 3 volt Lithium battery (IC697ACC701) to save the exception log contents for longer periods.

Station Mgr (RS-232) Serial Port

The 6-pin RJ-11 *phone jack* RS-232 serial port is used to connect a terminal or terminal emulator to access the Station Manager software on the Ethernet Interface. The pin assignments for this connector are shown in Table 2.

Table 2. Station Mgr (RS-232) Port Pin Assignment

Pin Number	Signal	Description
1	CTS	Clear to Send (input)
2	TD	Transmit Data (output)
3	SG	Signal Ground
4	SG	Signal Ground
5	RD	Receive Data (input)
6	RTS	Request to Send (output)

Use the available serial cable (IC693CBL316) to connect a terminal or PC to the Station Mgr (RS-232) serial port. Refer to Appendix B of the User's manual for more information.

Software Load (RS-485) Serial Port

The 15-pin D-type RS-485 serial port is used to connect a PC running the PC Software Loader software to the Ethernet Interface in order to update the firmware in the Ethernet Interface. The pin assignments for this connector are shown in Table 3.

Table 3. Software Load (RS-485) Port Pin Assignment

Pin Number	Signal	Description
1	Shield	
2	NC	No Connection
3	NC	No Connection
4	NC	No Connection
5	+5V *	+5V power for RS-232/RS-485 converter
6	RTS (A)	Request to Send (output)
7	Signal Ground	Signal Ground, 0V
8	CTS (B')	Clear to Send (input)
9	RT *	Terminating Resistor for RD **
10	RD (A')	Receive Data (input)
11	RD (B')	Receive Data (input)
12	SD (A)	Send Data (output)
13	SD (B)	Send Data (output)
14	RTS (B)	Request to Send (output)
15	CTS (A')	Clear to Send (input)

GFK-1309E
September 1998

Ethernet Interface (Type 2)

Use and RS-232/RS-485 adapter to connect systems taht provide an RS-232 interface to the Software Load (RS-232) serial port on the Ethernet Interface.

Catalog number IC690ACC900 is an RS-232/RS-485 converter; Miniconverter Kit IC690ACC901 also contains an RS-232/RS-485 converter. Refer to Appendix B of the User’s Manual for more information.

10BaseT Network Port

The 8-pin RJ-45 *phone jack* 10BaseT network port is used to connect a twisted-pair cable from a 10BaseT hub or repeater directly to the Ethernet Interface without an external transceiver. The pin assignments for this connector are shown in Table 4.

Table 4. 10BaseT Network Port Pin Assignment

Pin Number	Signal	Description
1	TD+	Transmit Data+ (output)
2	TD-	Transmit Data - (output)
3	RD+	Receive Data+ (input)
4	NC	No Connection
5	NC	No Connection
6	RD-	Receive Data- (input)
7	NC	No Connection
8	NC	No Connection

AUI Port

The 15-pin AUI network port connects the transceiver cable to the Ethernet Interface. The external 802.3 transceiver connects to the Ethernet network. Connector pin assignments are shown in Table 5.

Caution

PLC power must be OFF when connecting or disconnecting the transceiver.

Note

Transceivers must be 802.3-compatible and must have the SQE option Enabled.

Replaceable +12 VDC Fuse

A replaceable fuse is available on the +12 VDC power that is supplied by this module to the AUI port to power external transceivers.

Table 5. AUI Port Pin Assignment

Pin	Signal	Description
1	GND	SignalGround
2	CP+	CollisionPresence +
3	TX+	Transmit +
4	GND	SignalGround
5	RX+	Receive +
6	GND	SignalGround
7	NC	No Connection
8	GND	SignalGround
9	CP-	CollisionPresence -
10	TX-	Transmit -
11	GND	SignalGround
12	RX-	Receive -
13	+12	+12 Volts
14	GND	SignalGround
15	NC	No Connection
Shell	PG	ProtectiveGround

10Base2 Network Port

The BNC 10Base2 network port is used to connect a 10Base2 (ThinWire) network directly to the Ethernet Interface without an external transceiver. The 10Base2 network cables are attached to the Ethernet Interface with a T or F BNC connector.

Onboard 10Base2 Port Transceiver Power Disable Jumper

This jumper must be in place to ensure proper network operation when using an external transceiver connected to the AUI port that is *externally* powered.

Default Stations Address Label

The Default Station (MAC) Address label lists the station address to be used by this module, unless a locally assigned address is set by the user via the Station Manager. It is found on the inside edge of the protruding flange of the module faceplate. The Default Station Address label is visible when the Ethernet Interface module is inserted in the PLC rack.

Ethernet Interface (Type 2)

GFK-1309E
September 1998

Installation

This section describes the physical installation of the Ethernet Interface into the IC697 PLC rack. The installation process is completely described in the *Installation* chapter of the User's Manual.

1. Read and record the 12-digit Default Station Address from the printed label on the Ethernet Interface.

A Station Configuration Data Form is provided in the User's Manual, for your convenience in recording the Station Configuration Information.

2. Be sure the IC697 PLC rack power is OFF.
3. Slide the Ethernet Interface into the slot for which it was configured in the system - normally the first available slot to the right of the CPU or Bus Transmitter Module (BTM)

Press the board firmly in place, but do not force the board. Tighten the screws on the top and bottom tabs.

Note

The Ethernet Controller will not operate properly if there are empty slots to its left.

4. Connect **one** of the network ports on the Ethernet Interface to the Ethernet network. If you are using an external transceiver, connect the transceiver cable to the AUI port on the Ethernet Interface. The other end of the transceiver cable should be connected to an external IEEE 802.3 compatible transceiver that is connected to the Ethernet network.

Warning

PLC power must be OFF when connecting or disconnecting the transceiver.

Note

Transceivers must be 802.3-compatible and must have the SQE option Enabled.

Note

When using an external transceiver that is **externally** powered (that is, it does not require +12 VDC current from the AUI port), the *Disable Onboard 10Base2 Port* jumper must be in place to ensure proper network operation.

5. Set the CPU Run/Stop switch to STOP.
6. Power up the PLC rack.

Configuring the Ethernet Interface

Essential network addresses for each Ethernet Interface are setup by the MS-DOS® or Windows® PLC Configuration Software and stored to the PLC. These addresses *must be properly configured* before the Ethernet Interface can be used by your application. The configuration process is completely described in Procedure 2 in the *Installation* chapter of the User's Manual.

Powering-Up the Ethernet Interface

After the Ethernet Interface has been properly configured, turn power OFF to the PLC rack for 3 to 5 seconds, then turn power back ON.

During Power-Up:

The MODULE OK LED on the Ethernet Interface will BLINK while the Interface performs power-up diagnostic tests, and continue to blink while waiting for configuration data from the PLC CPU.

After Power-Up:

The MODULE OK LED should stop blinking, and should remain ON.

The LAN LED may be ON, OFF, or BLINKING - depending upon network activity.

The STATUS LED should be ON, indicating no exception conditions.

The LED indications described above indicate that the Ethernet Interface is ready for use.

GFK-1309E
September 1998

Ethernet Interface (Type 2)

Corrective Actions:

If the MODULE OK LED is OFF, a hardware fault has occurred, either in the Ethernet Interface or in the PLC, that prevents the Ethernet Interface from operating. Refer to the *Installation and Troubleshooting* chapters of the User's Manual for detailed troubleshooting information.

If the MODULE OK LED is ON, but the STATUS LED is OFF, an operational problem has occurred. Refer to the *Troubleshooting* chapter of the User's Manual for detailed troubleshooting information.

Station Management

Operating a local area network entails certain LAN management activities such as network performance measurement, status information, and fault diagnosis.

The Ethernet Interface contains many features to support these activities. Some of these features are accessed via the Station Manager, a portion of the Ethernet Interface operating firmware that responds to user commands. The Station Manager operates locally via an ASCII terminal or terminal emulator connected to the Station Mgr (RS-232) serial port, or remotely over the Ethernet LAN. Refer to the *TCP/IP Ethernet Communications Station Manager Manual* for complete information on the Station Manager.

Related Publications (Factory LAN)

The following documents are related user documentation for the Factory LAN family of communication products.

- *TCP/IP Ethernet (Type 2) Communications User's Manual*
- *TCP/IP Ethernet Communications Station Manager Manual*
- *PLC Programming Software User's Manual*
- *PLC Programmer TCP/IP Ethernet User's Manual Supplement*
- *PLC Programmer TCP/IP Windows[®] 95/Windows NT[®] User's Manual Supplement*
- *Programmable Controller Reference Manual*
- *Programmable Controller Installation Manual*
- *Host Communications Toolkit C/C++ and Visual Basic User's Manual*
- *Host Communications Drivers for Microsoft Windows User's Manual*

Ethernet Interface (Type 2)

GFK-1309E
September 1998

Table 6. Specifications for IC697CMM742 †

<p>General Specifications:</p> <p>Module Operating Voltage</p> <p>Module Current Drain</p> <p>Module Operating Temperature</p> <p>LED Indicators</p> <p>Connectors</p> <p>Fuse, Replaceable</p>	<p>+5 VDC, +12 VDC (from PLC power supply)</p> <p>2.0 Amps (+5 VDC), typical 0.5 Amps (+12 VDC), maximum when powering an external AUI transceiver</p> <p>0° C to +55° C (32° F to 131° F), ambient</p> <p>MODULE OK LAN ONLINE SERIAL ACTIVE STATUS</p> <p>– Station Manager (RS-232) Port: 6-pin female RJ-11 – Software Load (RS-485) Port: 15-pin female D-connector – 10BaseT Port: 8-pin female RJ-45 – AUI Port: 15-pin female D-connector with slide-lock – 10Base2 port: female BNC connector</p> <p>5 x 20mm, 250V, 1.0A, slow acting</p>
<p>Interface Specifications:</p> <p>LAN</p> <p>Serial Ports</p> <p>Network Ports</p>	<p>IEEE 802.2 Logical Link Control Class I IEEE 802.3 CSMA/CD Medium Access Control 10Mbps</p> <p>Station Mgr Port: RS-232 DTE 300 - 19200 bps Software Load Port: RS-485 DTE 300 - 19200 bps</p> <p>10BaseT Port: Ethernet, IEEE 802.3 CSMA/CD 10Base2 Port: Ethernet, IEEE 802.3 CSMA/CD AUI Port: Ethernet, IEEE 802.3 CSMA/CD (transceiver SQE must be enabled)</p>

† Refer to GFK-0867B, or later for product standards and general specifications. For installations requiring compliance to more stringent requirements (for example, European Union), refer to *Installation requirements for Conformance to Standards*.

Table 7. Ordering Instructions

Description	Catalog Number
Ethernet Interface (Type 2) for IC697 PLC (includes User's Manual)	IC697CMM742
[Optional]: Station Manager cable for Ethernet Interface (includes Station Manager Manual)	IC693CBL316
[Optional]: PLC Programmer TCP/IP Ethernet (MS-DOS Version)	IC641SWC713 or IC641SWM713
PLC Programmer TCP/IP Ethernet (Windows Version)	IC641SWC716 or IC641SWM716

Note: For Conformal Coat option, or Low Temperature Testing option please consult the factory for price and availability.

Table 8. Required PLC Power Supplies (with +12 VDC Output)

Description	Catalog Number
IC697 PLC Power Supply: 120/240 VAC or 125 VDC Input, 55 watt (only if AUI port not in use)	IC697PWR710
IC697 PLC Power Supply: 120/240 VAC or 125 VDC Input, 100 watt	IC697PWR711
IC697 PLC Power Supply: 24 VDC Input, 90 watt	IC697PWR724
IC697 PLC Power Supply: 48 VDC Input, 90 watt	IC697PWR748

