

Manual of Operation and Instruction

Model 3430
(and Model 3430-M)

**Surface
Moisture-Density
Gauge**



Troxler Electronic Laboratories, Inc.

3008 Cornwallis Rd. • P.O. Box 12057

Research Triangle Park, NC 27709

Phone: 1.877.TROXLER

Outside the USA: +1.919.549.8661

Fax: +1.919.549.0761

www.troxlerlabs.com

**The Troxler Model 3430 Surface Moisture-Density Gauge
is protected by U.S. and Foreign Patents**

Copyright © 1990–2006

Troxler Electronic Laboratories, Inc.

All Rights Reserved

No part of this manual may be reproduced or transmitted in any form or by any means, electronic or mechanical, including photocopying, recording, or information storage and retrieval systems, for any purpose without the express written permission of Troxler Electronic Laboratories, Inc.

Fantastic is a trademark of Dow Consumer Products, Inc.

Federal Express is a registered trademark of the Federal Express Corporation.

409 is a trademark of the Clorox Company.

Magnalube-G is a registered trademark of Carleton-Stuart Corporation.

WD-40 is a registered trademark of the WD-40 Company.

PN 105305
December 2006
Edition 8.1

TROXLER SERVICE CENTERS

Troxler Corporate Headquarters

3008 Cornwallis Road

P.O. Box 12057

Research Triangle Park, NC 27709

Phone: 1.877.TROXLER (1.877.876.9537)

Outside the U.S.A.: +1.919.549.8661

Fax: +1.919.549.0761

Web: www.troxlerlabs.com

Technical Support

Phone: 1.877.TROXLER (1.877.876.9537)

E-mail: TroxTechSupport@troxlerlabs.com

Midwestern Branch Office

1430 Brook Drive

Downers Grove, IL 60515

Fax: 630.261.9341

Florida Service Center

2376 Forsyth Road

Orlando, FL 32807

Fax: 407.681.3188

Western Regional Branch Office

11300 Sanders Drive, Suite 7

Rancho Cordova, CA 95742

Fax: 916.631.0541

Troxler European Subsidiary

Troxler Electronics GmbH

Gilchinger Strasse 33

D.82239 Alling nr. Munich, Germany

Phone: ++49.8141.71063

Fax: ++49.8141.80731

E-mail: troxler@t-online.de

Southwestern Branch Office

2016 East Randol Mill Road

Suite 406

Arlington, TX 76011

Fax: 817.275.8562

NOTE

To locate an independent, Troxler-authorized service center near you, call 1.877.TROXLER (1.877.876.9537).



CAUTIONS AND WARNINGS



Units intended for use in countries that are members of the European Community are shipped with a CE-approved AC adapter, Troxler bin number 108354.



Gauge cover is to be removed by trained service personnel only. There are no user-serviceable components inside. Note that components behind the cover can have voltage potentials in excess of 50 volts during normal operation of the gauge.



Appendix A, *Radiation Theory and Safety* should be read carefully and understood before using the gauge.



See page C-8, *Alkaline Battery Use*.



The source rod should automatically retract to the **SAFE** position when the gauge is lifted by the handle.



See page C-12, *Tungsten Sliding Block*.

EU DECLARATION OF CONFORMITY

Application of Council EMC Directive 89/336/EEC and Low Voltage Directive 73/23/EEC

Standards to which Conformity is Declared:

EN 61010-1
EN 55011 Group 1, Class A
EN 50082-2

An **EMC Technical Report/Certificate** has been issued in accordance with Part IV (Reg 50) of the UK Regulations (SI 1992 No. 2372) by a UK appointed Competent Body, namely,

Interference Technology International Limited
41-42 Shrivenham, Hundred Business Park
Shrivenham, Swindon, Wiltshire SN6 8TZ

Certificate Number C283TRO.1ABS Dated 16th January 1997
Troxler Document Number 108205

Manufacturer: Troxler Electronic Laboratories, Inc.
PO Box 12057
3008 Cornwallis Road
Research Triangle Park, North Carolina 27709
USA

Apparatus: Model 3430 Surface Moisture-Density Gauge

Year of Declaration: 1997 (Original)
2006 (Corrected)

HOW TO USE THIS MANUAL

Congratulations on the purchase of the **Troxler Model 3430 Surface Moisture-Density Gauge**.

The **Model 3430 Manual of Operation and Instruction** contains information on how the **Model 3430** operates, and provides directions on the use of this gauge. Site selection, basic parameter setup, moisture and density determination, storage, and advanced operations are included, along with radiological information and system troubleshooting.

GUIDE TO SYMBOLS AND FORMATTING

Throughout this manual, symbols and special formatting are used to reveal the purpose of the text as follows:

- CAUTION** Indicates conditions or procedures that, if not followed correctly, may cause personal injury or equipment damage.
- NOTE** Indicates important information that must be read to ensure proper operation.
- ◆ Diamonds indicate a list of things needed (such as equipment) or things to know.
 - ✓ Check marks indicate the performance of an action. With lists of check marks, follow the instructions in the order of the check marks.
 - ▶ Triangles indicate that more than one option is available. Carefully select the option that applies.
- <KEY>** Angle brackets and a different typestyle indicate a key or character (number or letter) to press on the control unit keypad. For example, “Press **<STD>**” means to press the key labeled *STD*.
- DISPLAY** A different typestyle is also used to indicate text displayed on the control unit.

TABLE OF CONTENTS

CHAPTER 1. INTRODUCTION TO THE MODEL 3430

Introduction.....	1-2
Gauge Parts and Accessories	1-4
Unpacking and Inspection	1-6
Storage Site Selection	1-7

CHAPTER 2. THEORY OF OPERATION

Density	2-2
Moisture.....	2-5

CHAPTER 3. OPERATING THE GAUGE

The Keypad.....	3-2
Source Rod Positions	3-4
Daily Inspection.....	3-5
Turning the Gauge On	3-6
Gauge Parameter Setup.....	3-7
Taking the Standard Count	3-10
Site Preparation/Gauge Positioning	3-12
Taking a Measurement – Soil Mode.....	3-15
Taking a Measurement – Asphalt Mode.....	3-17

CHAPTER 4. ADVANCED GAUGE OPERATION

Offsets.....	4-2
Special Calibrations	4-7
Thin Layer Measurements	4-11

CHAPTER 5. SPECIAL FUNCTIONS

Recall	5-2
Offset	5-2
Stat Test	5-2
Drift Test.....	5-5
Special Calibration.....	5-7
Specific Gravity	5-7
Voidless Density	5-8
Set Units.....	5-8
Calibration Constants.....	5-9
Memory Reset.....	5-10
Test Reading	5-10
Language.....	5-11

TABLE OF CONTENTS (Continued)

APPENDIX A. RADIOLOGICAL INFORMATION

Radiation Theory	A-2
Radiation Safety	A-5

APPENDIX B. SPECIFICATIONS

Measurement	B-2
Radiological	B-4
Electrical.....	B-5
Mechanical	B-6

APPENDIX C. TROUBLESHOOTING AND SERVICE

Troubleshooting.....	C-2
Battery Charging	C-8
Mechanical Maintenance.....	C-10
Leak Testing	C-15
Replacement Parts	C-16
Returning the Gauge for Service	C-26
Troxler Service Centers.....	C-28

APPENDIX D. TRANSPORTATION AND SHIPPING

U.S. Requirements.....	D-2
Canadian Shipping Requirements	D-4

APPENDIX E. STANDARD COUNT LOG

APPENDIX F. UNIT CONVERSION

Measurement Units.....	F-2
Radiological Units.....	F-2

INDEX

WARRANTY

LIST OF FIGURES

<u>Figure</u>	<u>Title</u>	<u>Page</u>
1-1	Model 3430 Gauge and Accessories	1-5
2-1	Direct Transmission Geometry	2-3
2-2	Backscatter Geometry	2-3
2-3	Backscatter Surface Density Effects (Top Layer Effect Curves)	2-4
2-4	Effect of Moisture on Depth of Measurement.....	2-6
3-1	Model 3430 Keypad.....	3-2
3-2	Source Rod Positions	3-4
3-3	Standard Count Position.....	3-11
3-4	Drill Rod Positioning	3-12
3-5	Marking the Test Area	3-13
3-6	Voids Illustration.....	3-16
A-1	Diagram of an Atom.....	A-2
A-2	Variation of Radioactive Emission	A-4
A-3	Effect of Distance on Exposure.....	A-6
A-4	Model 3430 Gauge and Transport Case.....	A-8
C-1	Removing the Tungsten Sliding Block	C-13
C-2	3430 Gauge Assembly	C-17
C-3	3430 Gauge Base Mechanical Assembly	C-19
C-4	3430 Source Rod Handle Assembly.....	C-19
C-5	3430 Gauge Preamplifier Assembly	C-21
C-6	3430 Gauge Scaler Assembly	C-23

LIST OF TABLES

<u>Table</u>	<u>Title</u>	<u>Page</u>
3-1	Model 3430 Keypad Functions.....	3-3
4-1	K Values for Thin Lift Overlays.....	4-13
A-1	Radiation Profile for Model 3430 Gauge.....	A-9
A-2	Radiation Profile for Model 3430-M Gauge.....	A-10

ATTENTION GAUGE OWNER

This gauge contains functions that require an ACCESS CODE. This code must be entered before these functions may be used. For more information on using the access code refer to the specific function in Chapter 5.

The ACCESS CODE for this gauge is:

4678

This page should be removed if the access code is not to be distributed to other parties or users of this gauge.

NOTES

CHAPTER 1**INTRODUCTION TO THE MODEL 3430**

This chapter provides a general introduction to the Model 3430 Surface Moisture-Density Gauge and its applications. Also included are a list of the gauge parts and accessories, instructions for unpacking and inspecting the system, and guidelines for site selections.

CONTENTS

Introduction.....	1-2
Gauge Parts and Accessories	1-4
Unpacking and Inspection	1-6
Storage Site Selection	1-7

INTRODUCTION

The Model 3430 Surface Moisture-Density Gauge can quickly and precisely determine the moisture and density of soils, soil bases, aggregate, concrete and asphaltic concrete without the use of core samples or other destructive methods.

Using direct transmission or backscattered gamma radiation, the 3430 gauge determines the density of materials by counting the number of photons emitted by a cesium-137 source. Geiger-Mueller (G-M) detectors located in the gauge base detect the gamma radiation and a microprocessor converts the counts into a density reading.

Using the principle of neutron thermalization, the Model 3430 determines the moisture content of soils and soil-like materials. Hydrogen (water) in the material slows neutrons emitted from an americium-241:beryllium source (or californium-252 in the Model 3430-M). Helium-3 detectors located in the gauge base detect the slowed neutrons.

The nuclear method of testing density and moisture has been approved by the American Society of Testing and Materials (ASTM). The Model 3430 meets or exceeds all the requirements of ASTM Standards C1040, D2922, D2950, and D3017.

Some information contained in this manual is used in training courses offered by Troxler Electronic Laboratories, Inc. and to assist purchasers in obtaining a Radioactive Materials License from the U.S. Nuclear Regulatory Commission or an Agreement State. Owners of this gauge must maintain a current radioactive materials license as long as they own the gauge, even if it is in storage and not actively being used.

Any licensing issues discussed in this manual are for the United States. To purchase a Model 3430 in Canada, owners must obtain a radioisotope license from the Canadian Nuclear Safety Commission (CNSC). The owner should obtain copies of the CNSC Regulations and the Transportation of Dangerous Goods Act and Regulations. This manual provides a guide to Canadian shipping requirements in Appendix D.

Owners are encouraged to require study of this manual by users before allowing any use of the instrument. To monitor exposure to radiation, personnel should wear a dosimeter while operating or cleaning the gauge. The sections of the manual covering radiation safety should be required reading for all operators and potential operators. **If these sections are not completely understood, users should seek assistance from Troxler, an appointed Troxler representative or others designated within the user organization.** Additional radiation safety information is available by attending a *Troxler Nuclear Gauge Training Course*.

As changes are made to local, state, and federal regulations on a continuing basis, the owner/user must maintain a knowledge of these regulations. *The responsibility for compliance ultimately falls upon the owner.* The owner may also wish to purchase and subscribe to Titles 10 and 49 of the *Code of Federal Regulations* in addition to applicable local/state regulations.

NOTE

This manual also contains radiological information for the Model 3430-M. The 3430 and 3430-M have the same functions and operational aspects but different neutron sources.

GAUGE PARTS AND ACCESSORIES

Figure 1-1 shows the Model 3430 gauge and its accessories. Use this figure and the list below to identify the gauge and parts as they are unpacked.

1. The **Gauge** is a portable instrument containing all electronic modules, battery packs, detectors, and radioactive sources.
2. The **Reference Standard Block** provides a uniform reference material for gauge adjustment to compensate for source decay.
3. The **Scraper Plate/Drill Rod Guide** is used to prepare the test site and aid in guiding the drill rod into the soil.
4. The **Drill Rod** is used to prepare a hole for a direct transmission reading. **Do Not Use the Source Rod For This Purpose!**
5. Two **Chargers/Adapters** are supplied: one for DC (12 VDC) and one for AC (115/230 VAC 50/60 Hz.)
6. The **Transport Case** is a container designed for transportation of the gauge and associated parts.
7. The **Extraction Tool** provides a means of removing the drill rod from the test material after use.

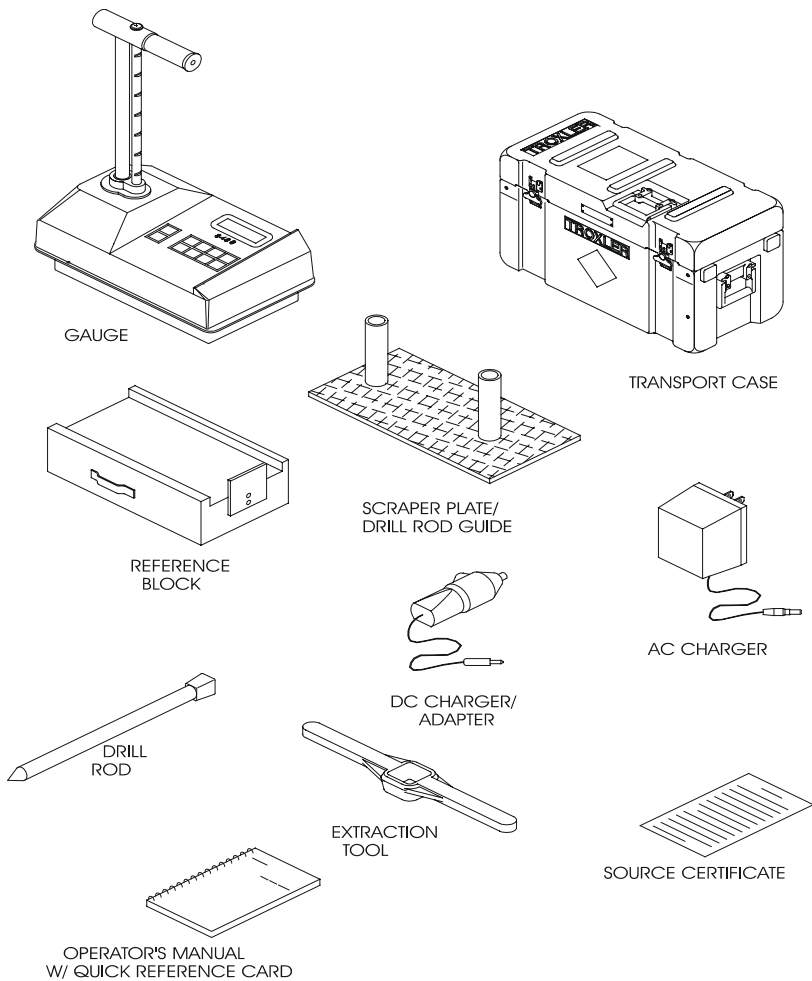

Figure 1-1. Model 3430 Gauge and Accessories

UNPACKING AND INSPECTION

Upon receipt of the gauge from the factory, a complete inspection and inventory should be performed. If the shipping case, any other part of the container, or the gauge appears to be damaged, notify the carrier and your Troxler Representative **immediately**.

For shipping to another location or back to the factory, save the box and any packing material. For shipping instructions and regulations, please see Appendix D.

Check to see if the following literature and components have been included:

- ◆ Manual of Operation and Instruction
- ◆ Gauge Warranty
- ◆ Source Certificate
- ◆ 3430 Gauge
- ◆ Scraper Plate
- ◆ Drill Rod
- ◆ AC Battery Charger
- ◆ DC Charger/Adapter
- ◆ One handle lock with keys

Lift the gauge from the case. Inspect the gauge for damage. Check the lock on the handle. Ensure the keys fit the lock.

STORAGE SITE SELECTION

When deciding where to store the gauge, take into consideration the rules governing the storage of low-level radioactive devices that are set forth by your regulatory agency and the conditions of your gauge license.

- ◆ The handle should be locked and the gauge stored in its transport case.
- ◆ It is recommended that the gauge and transport case be stored at least 15 ft (5 m) from work areas, preferably in a locked closet/storage area in a dry location (indoors).
- ◆ The storage area should be marked with a radiation sign that reads “**CAUTION RADIOACTIVE MATERIALS**” (can be obtained from Troxler).
- ◆ The storage of a nuclear gauge in a motor vehicle is not recommended.

NOTES

CHAPTER 2

THEORY OF OPERATION

This chapter contains a brief description of the theory of operation of the Model 3430 Surface Moisture-Density Gauge. The direct transmission and backscatter modes of operation are illustrated along with a brief explanation of the cesium-137 source, americium-241:beryllium or californium-252 source, and detector geometry.

CONTENTS

Density	2-2
Moisture	2-5

DENSITY

The Troxler Model 3430 gauge utilizes two modes of operation: *direct transmission mode* (source rod extended into the material) and *backscatter mode*. Figures 2-1 and 2-2 illustrate the two modes of operation.

In *direct transmission mode* (Figure 2-1), the rod containing the cesium-137 (8 mCi/0.3 GBq) source is lowered to the desired depth. The detectors (G-M tubes) in the gauge base measure the radiation emitted by the source rod. Gamma photons reaching the detectors must first pass through the material, colliding with electrons present in the material. In general, the lower the number of photons that reach the detectors, the higher the material density.

In *backscatter mode* (Figure 2-2), the gamma photons that enter the material must be scattered (or reflected) at least once to reach the detectors in the gauge. With the rod locked in the first notch below the **SAFE** position, the source and detectors are in the same plane, referred to as the backscatter position. Photons emitted from the source penetrate the material, and the detectors measure the scattered photons. Shielding between the source and detectors greatly reduces the number of photons reaching the detectors in a direct path with the source.

While the direct transmission geometry measures the average density of the material from the source to the surface, the backscatter geometry yields an average heavily weighted by the density close to the surface. Figure 2-3 shows two normalized *top layer effect curves*, illustrating the percentages of photons at the detectors for various depths. The two curves can be used to compute the gauge response to layered material of different densities. For example, the density of the top inch of a surface layer accounts for approximately 52% of the backscatter density measurement.

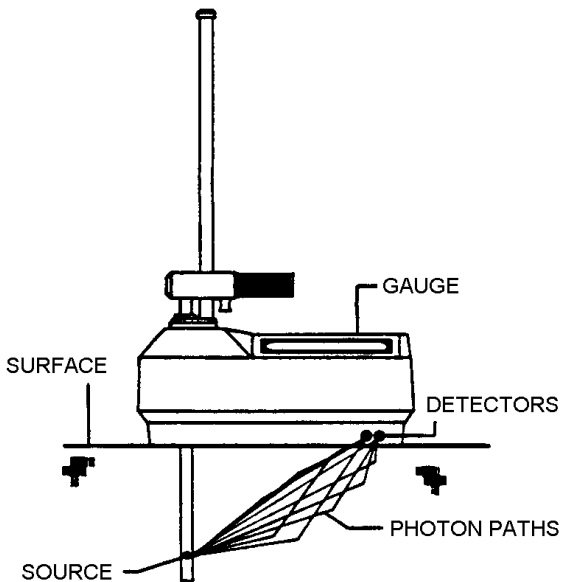

Figure 2-1. Direct Transmission Geometry

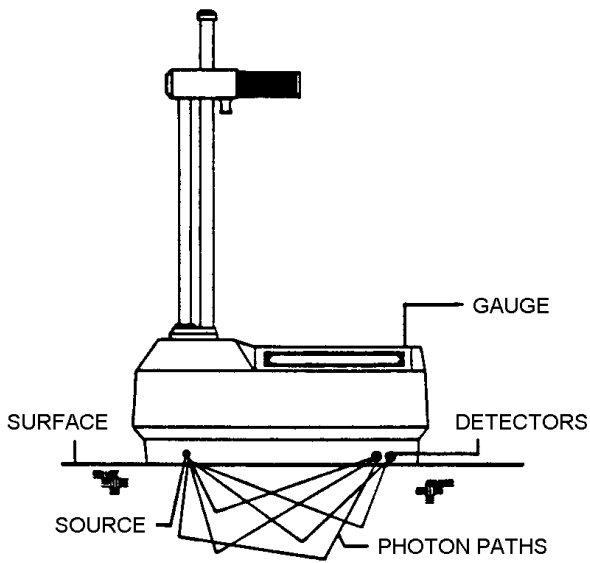
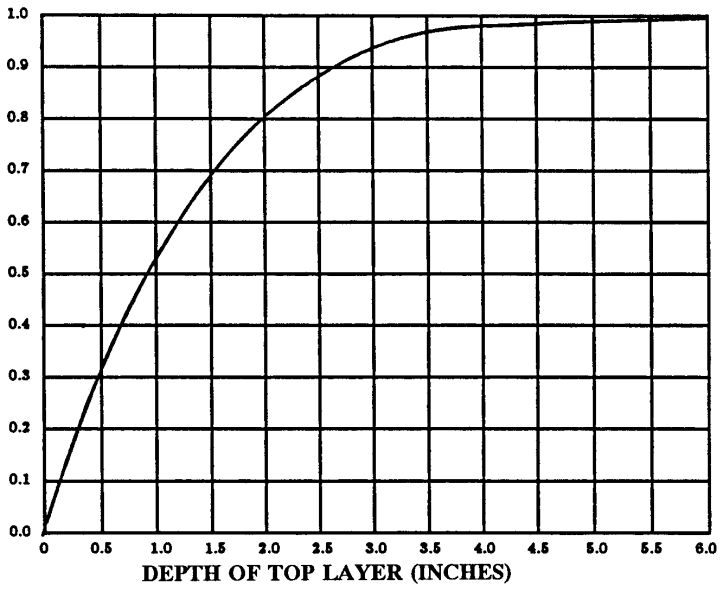

Figure 2-2. Backscatter Geometry

T
O
P
L
A
Y
E
R
E
F
F
E
C
T



T
O
P
L
A
Y
E
R
E
F
F
E
C
T

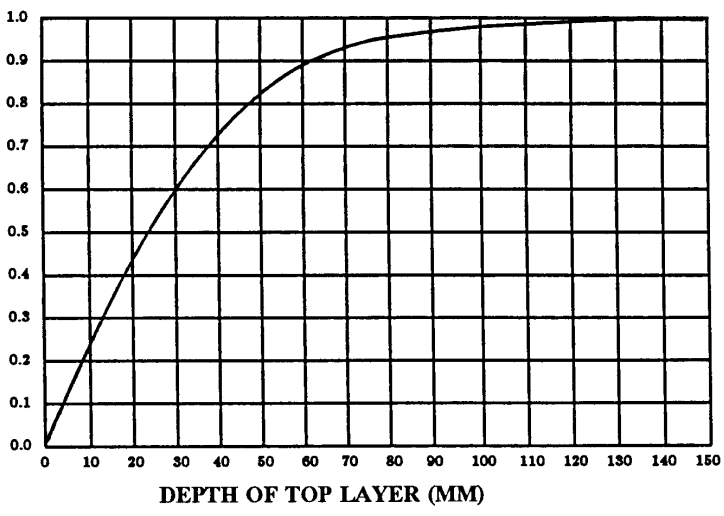

Figure 2-3. Backscatter Surface Density Effects
(Top Layer Effect Curves)

MOISTURE

The Model 3430 gauge uses a 40 mCi (1.48 GBq) americium-241:beryllium neutron source to measure the hydrogen content (consequently the water content) of the material. The 3430-M gauge employs a 60 μ Ci (2.22 MBq) californium-252 source.

Neutrons emitted by the Am-241:Be (or Cf-252) source penetrate the material and are *thermalized* (or slowed). *Thermalization* is the process where neutrons are slowed to the point where further collisions with hydrogen or other materials will not continue to slow the neutron.

The 3430 gauge contains a helium-3 neutron detector that is sensitive to thermalized neutrons. This detector is insensitive to non-thermalized, or “fast” neutrons and, as a result, the counts obtained are directly proportional to the amount of hydrogen/moisture present in the material.

The depth of measurement, or depth at which 98% of the counted neutrons pass before reaching the detector, is a function of moisture content:

$$\text{Depth (inches)} = 11 - (0.17 \times M), \text{ where: } M = \text{moisture in } \text{pcf}$$

or

$$\text{Depth (mm)} = 280 - (0.27 \times M), \text{ where: } M = \text{moisture in } \text{kg/m}^3$$

Therefore, the higher the moisture content in the material being measured, the smaller the depth of measurement. The normalized curve set shown in Figure 2-4 illustrates the effect of moisture content on the depth of measurement.

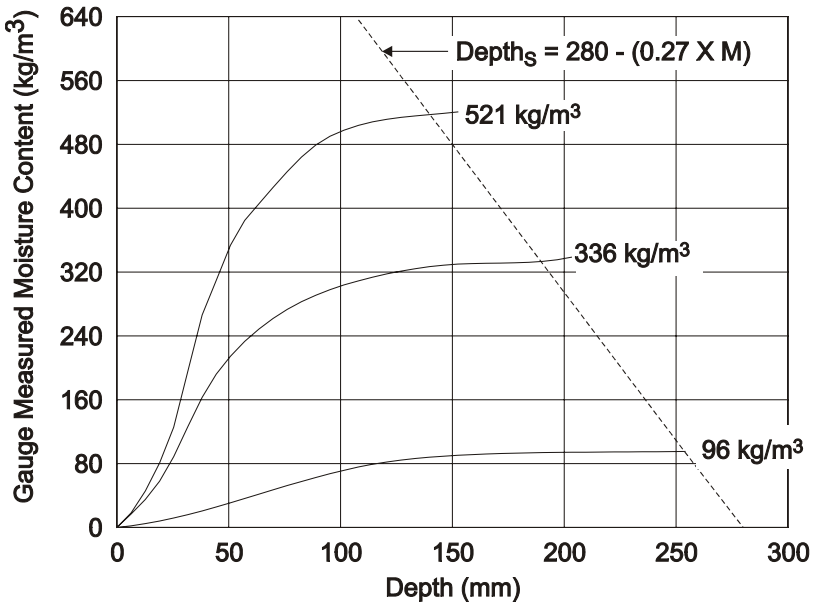
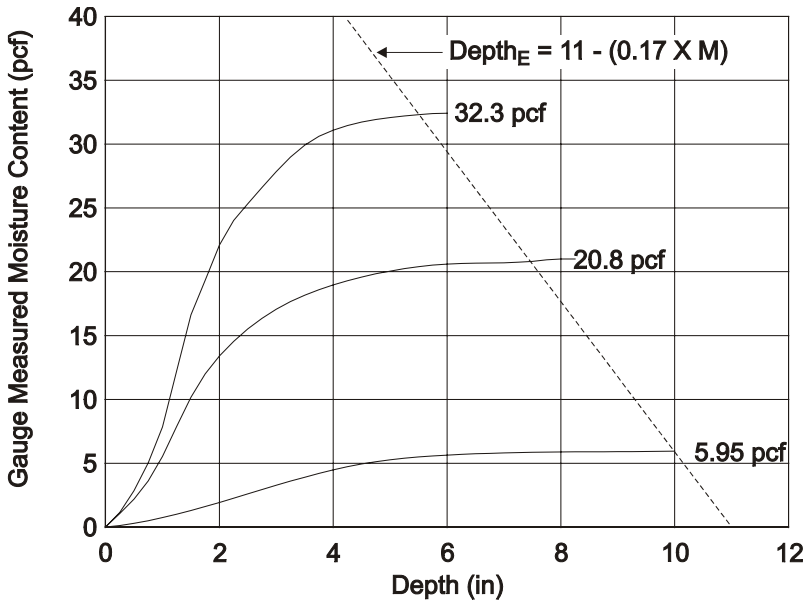

Figure 2-4. Effect of Moisture on Depth of Measurement

CHAPTER 3

OPERATING THE GAUGE

This chapter explains the basic operation of the Model 3430 Surface Moisture-Density Gauge. Instructions for conducting a daily gauge inspection, setting gauge parameters, taking the daily standard count, preparing the site, positioning the gauge, and taking moisture and density measurements are included.

CONTENTS

The Keypad.....	3-2
Source Rod Positions	3-4
Daily Inspection.....	3-5
Turning the Gauge On	3-6
Gauge Parameter Setup.....	3-7
Setting Measurement Units	3-7
Setting the Count Time	3-8
Setting the Depth.....	3-8
Selecting the Mode (Marshall/Proctor)	3-8
Taking the Standard Count	3-10
Site Preparation/Gauge Positioning	3-12
Soil and Base Course Preparation	3-12
Asphalt Surface Preparation.....	3-14
Taking a Measurement – Soil Mode.....	3-15
Taking a Measurement – Asphalt Mode.....	3-17
Model 3430	3-1

THE KEYPAD

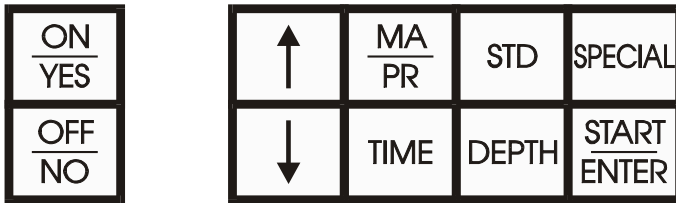

Figure 3-1. Model 3430 Keypad

The keypad (Figure 3-1) of the Model 3430 Surface Moisture-Density Gauge consists of ten keys — an eight-function keypad and the **⟨ON/YES⟩** and **⟨OFF/NO⟩** keys. The gauge is equipped with a beeper to verify keystrokes. If a *beep* is not heard when a key is pressed, the keystroke was not recognized and should be repeated. The **⟨ON/YES⟩** and **⟨OFF/NO⟩** keys are used for responses to specific questions displayed on the screen and to turn the gauge on and off.

The up and down arrows allow the operator to scroll through various function lists displayed by the gauge.

Table 3-1 provides a more detailed description of the individual keys and the location in the manual where the functions are described.

Table 3-1. Model 3430 Keypad Functions

KEYS	DESCRIPTION	PAGE
<u>ON</u> <u>YES</u>	Turns on the gauge and answers <i>Yes</i> to prompts.	3-6
<u>OFF</u> <u>NO</u>	Turns gauge off and answers <i>No</i> to prompts	
↑	Scrolls the display up.	
↓	Scrolls the display down.	
<u>MA</u> <u>PR</u>	Allows entering or enabling of a Proctor or Marshall value.	3-9
TIME	Allows the operator to change the count time.	3-8
STD	Use to access the <i>Standard Count</i> mode.	3-10
DEPTH	Allows entry of the source rod depth.	3-8
SPECIAL	Provides access to the <i>Special</i> functions.	3-7, 4-3, 4-4, 4-7, 5-1
<u>START</u> <u>ENTER</u>	Starts a measurement or completes answer entry.	

GAUGE OPERATION

SOURCE ROD POSITIONS

Figure 3-2 shows the available positions of the source rod.



NOTE

The source rod should always be in the **SAFE** position when the gauge is not in use.

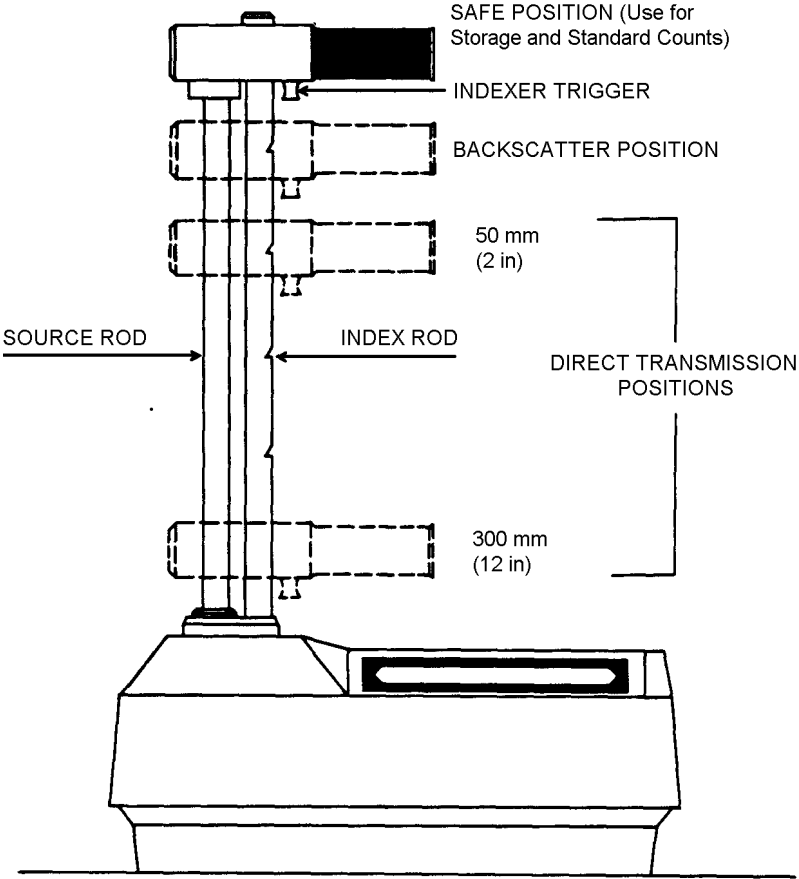

Figure 3-2. Source Rod Positions

DAILY INSPECTION

The gauge should be inspected daily before use to ensure proper operation of all safety features as follows:

- ✓ Push the source rod down into the backscatter position, and then raise it back to the **SAFE** (shielded) position. The source rod opening in the bottom of the gauge is equipped with a spring-loaded tungsten sliding block that shuts when the source rod is in the **SAFE** position. Turn the gauge over and verify that the sliding block is completely shut. If any portion of the opening is uncovered, the sliding block should be cleaned before using, transporting, or storing the gauge. Refer to the *Mechanical Maintenance* section of Appendix C for instructions on cleaning the tungsten sliding block.



CAUTION

Do not store or transport the gauge unless the sliding block is completely closed. Increased radiation levels may violate transportation regulations and cause excessive personnel radiation exposure.

- ✓ If a radiation survey instrument is available, verify that the radioactive gamma source is in place by measuring the exposure rate at the surface of the gauge. The exposure rate should be approximately 10 – 20 mrem per hour. A reading of about 1 mrem or less indicates either that the survey instrument is not working properly or that the cesium-137 source may be missing. Refer to the *Troubleshooting* section of Appendix C for further instructions.

TURNING THE GAUGE ON

The gauge uses rechargeable NiCad batteries (included) as a power source. When first turned on, the control panel displays test characters before proceeding to the self-test.

NOTE

If the gauge turns off immediately after it is turned on, the battery charge may be low or the gauge may be wet inside. Refer to the information in Appendix C on battery charging and gasket replacement.

To turn the gauge on, press **<ON/YES>**. The gauge performs a test of its liquid crystal display (LCD):

Testing LCD
0123456789ABCDEFG

After the 300-second self-test, the gauge will enter the *Ready* mode. In this state any of the gauge functions may be accessed.

The *Ready* mode display is:

<READY> xx min
Depth: xx inches

The first line of the display indicates the current *count time*. The second line of the display indicates the source rod depth that has been selected.

NOTE

The gauge will automatically turn off after five hours if no keys are pressed.

GAUGE PARAMETER SETUP

After unpacking the gauge and turning it on, there are several parameters that can be initialized. These parameters do not usually require changing and include the measurement units and count time.

SETTING MEASUREMENT UNITS

The 3430 gauge allows measurement results to be displayed in either metric or US units. To set the measurement units, first access the *Special* function menu by pressing **<SPECIAL>**.

– RECALL –
(↑ ↓ or ENTER)

Press the down arrow seven times to display:

– SET UNITS –
(↑ ↓ or ENTER)

To select *Set Units*, press **<START/ENTER>**.

Units: PCF
(↑ ↓ or ENTER)

Use the up and down arrows to scroll through the available units. When the desired units are displayed, press **<START/ENTER>**.

SETTING THE COUNT TIME

The *count time* defines how long the gauge reads. Longer count times produce better measurement precision. Troxler recommends a count time of one minute for most sample measurements.

To change the count time, press **<TIME>** to display:

Time: xx min.
(↑ ↓ or ENTER)

Use the up and down arrows to scroll through the available count times. When the desired count time is displayed, press **<START/ENTER>**.

SETTING THE DEPTH

To change the depth of measurement, press **<DEPTH>**.

Depth: xx in.
(↑ ↓ or ENTER)

Use the up and down arrows to scroll through the available measurement depths. When the desired depth is displayed, press **<START/ENTER>**.

SELECTING THE MODE (MARSHALL/PROCTOR)

The 3430 gauge may be used on construction materials (soils, asphalt, concrete, and so on). To select the *Soil* mode, enter or activate a Proctor value. To select the *Asphalt* mode, enter or activate a Marshall value. Only one Marshall and one Proctor can be stored in the gauge at one time.

NOTE

To measure concrete, use either the *Asphalt* or *Soil* mode. For moisture results select the *Soil* mode. For density measurement only, use the *Asphalt* mode.

To enter or activate a Marshall or Proctor value, press **<MA/PR>**. The display will be one of the following:



To switch from a Marshall value to a Proctor value, or vice versa, use the arrow keys.

To activate the displayed value, press **<OFF/NO>**.

To change the displayed value, press **<ON/YES>**. The first digit of the value will flash. Use the arrow keys to scroll through the possible entries (0 – 9 and .). When the correct value for the current digit is displayed, press **<START/ENTER>**. The gauge will proceed to the next digit to the right.

When the value entry is complete, the gauge activates the value and returns to the *Ready* mode.

TAKING THE STANDARD COUNT

The 3430 gauge uses a cesium-137 and an americium-241:beryllium source for taking measurements. These radioactive sources undergo a natural decay process, resulting in a gradual loss in the intensity of their radiation. The time required for the source strength to diminish by 50% is referred to as the *half-life*.

To compensate for the source decay and to check proper operation of the gauge, a daily reference *standard count* should be performed. To ensure the highest accuracy possible with the gauge, it is important to take a daily standard count.

The gauge is equipped with a reference standard block for taking the standard count. Place the reference standard block on a dry, flat surface at least three meters (10 ft) from any large vertical surface and at least ten meters (33 ft) from any other radioactive source. The surface should be asphalt, concrete or soil at least ten centimeters (4 in) thick and with a density of at least 100 pcf. The right side of the gauge, farthest from the handle, should be against the metal butt plate (Figure 3-3).

To begin the standard count procedure, press **<STD>**.

DS=xxxx MS=xxxx
New Std Cnt?

To take a new standard count, press **<ON/YES>**.

Press START for
Standard Count

Ensure that the gauge is positioned as shown in Figure 3-3. To initiate the standard count, press **<START/ENTER>**. After the count is complete, the display will be:

Standard Count:
DS=xxxx MS=xxxx

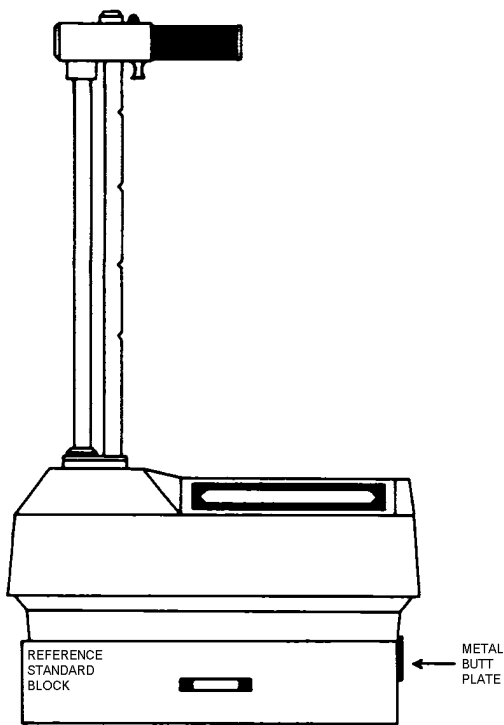

Figure 3-3. Standard Count Position

Troxler recommends that the operator keep a daily log of the moisture and density standard counts (see Appendix E). To verify gauge stability, compare the daily standard count to a reliable reference as follows:

- ◆ During the first four days of operation of a new or recalibrated gauge, compare the daily standard count to the factory calibrated values.
- ◆ After the first four days of operation (or after taking four standard counts), compare the daily standard count to the average of the last four counts. Acceptable standard count limits are:
 - ±1% each day for DS (density standard) and
 - ±2% each day for MS (moisture standard).

After recording the standard counts, return to the *Ready* mode by pressing **(ON/YES)**.

SITE PREPARATION/GAUGE POSITIONING

Preparation of the test site surface is critical to gauge performance. This section provides site preparation procedures for both soils and base courses and asphalt surfaces. To ensure the most accurate gauge readings, the appropriate preparation procedure should be followed.

SOIL AND BASE COURSE PREPARATION

- ✓ Since soil surface conditions are critical to accurate measurements, locate a level site free from any large holes, cracks, or debris.
- ✓ Smooth the surface by moving the scraper plate in a back and forth motion. Filler such as fine sand may be used to decrease the surface voids.

NOTE

Use only enough filler to fill the voids. Too much filler will cause an error in the measurement.

- ✓ For direct transmission measurements, put the drill rod through the extraction tool and then through one of the guides on the plate (see Figure 3-4).

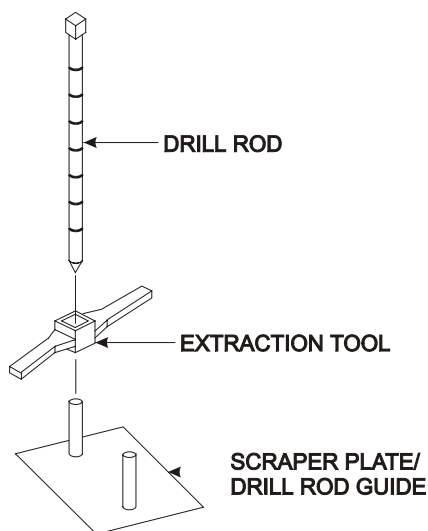

Figure 3-4. Drill Rod Positioning

- ✓ **Wearing a radiation badge and safety glasses (or other locally approved safety devices)**, step on the plate and hammer the drill rod at least 50 millimeters (2 in) deeper than the desired test depth. The drill rod increments include the additional depth.
- ✓ Remove the drill rod by pulling straight up and twisting the extraction tool. **Do not loosen the drill rod by tapping from side to side with a hammer.** This will distort the hole or cause loose material to fall into the hole.
- ✓ To ensure accurate placement of the gauge, before removing the scraper plate mark the test area using the drill rod as shown in Figure 3-5.
- ✓ Carefully pick up the scraper plate and place the gauge on the surface prepared by the plate. Insert the source rod into the hole made by the drill rod. **Use care when inserting the source rod, trying not to disturb the soil around the hole.**
- ✓ Lower the source rod into the hole. Release the trigger and lock the source rod into the correct position. A *click* should be heard when the source rod is locked into position.
- ✓ Gently slide the gauge toward the keypad so the source rod makes contact with the wall of the hole.

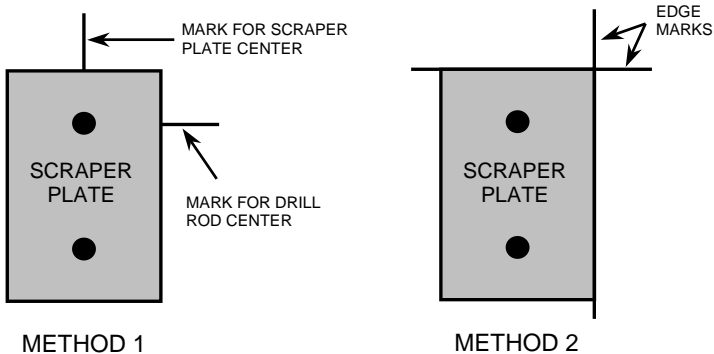

Figure 3-5. Marking the Test Area

ASPHALT SURFACE PREPARATION

It is possible, but usually not necessary, to take direct transmission readings on asphalt. Drilling a hole in asphalt can be difficult, and may require the use of a drill (rather than the drill rod) if the asphalt has cooled and hardened.

Under normal conditions, a backscatter reading provides an accurate measurement of asphalt density.

- ✓ Find a smooth, level location on the asphalt. The operator may want to fill the voids on open mixes with sand or cement. Take care to leave the asphalt exposed. **The gauge base must rest on the asphalt, not the fill material!**
- ✓ Ensure that the gauge does not “rock.” It must remain steady. If rocking occurs, find a more suitable test site. If taking a measurement around a core, the gauge may be moved a few inches away from the hole to level the gauge.

TAKING A MEASUREMENT – SOIL MODE

The *Soil* mode is automatically selected when a Proctor value is enabled (see page 3-8).



NOTE

When not taking measurements, always keep the source rod in the SAFE position. For added operator safety, the source rod on the 3430 gauge automatically retracts to the SAFE position when the gauge is lifted by the handle.

If you do not hear a *click* when the source rod is raised to the **SAFE** position, look at the bottom of the gauge to verify that the tungsten sliding block is completely closed. If the gauge base opening is not completely closed by the sliding block, the sliding block may require cleaning. Refer to Appendix C for cleaning instructions.



CAUTION

Do not store or transport the gauge unless the tungsten sliding block is completely closed. Increased radiation levels may violate transportation regulations and cause excessive personnel exposure.

Place the gauge over the test site. Release the gauge handle and push it down until it is in the correct position. Ensure that the pin engages the notch in the index rod.

Press **<START/ENTER>**.

Depth: xx in.
Time: xxx sec.

After the count time has elapsed, the gauge displays the measurement results in a series of six screens, as follows. Use the up and down arrows to scroll through the various screens.

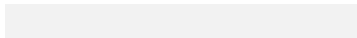

WD: xxxxx PCF
(Use ↑ & ↓ keys)

DD: xxxxx PCF
%PR: xx.x %

Moist: xxxxx PCF
% Moist: xx.x %

Air Void: xx.x%
Void Ratio

MOIST CR: xx.x
DENS CR: xx.x

M Count: xxxxx
D Count: xxxxx

where:

WD = Wet density in kg/m^3 or pcf

DD = Dry density in kg/m^3 or pcf

%PR = Percent Proctor (This value is valid only if an appropriate target has been entered for the material being tested.)

MOIST = Moisture value in kg/m^3 or pcf

% MOIST = Percent moisture

Air Void = See description below

Void Ratio = See description below

MOIST CR = Moisture count ratio

DENS. CR = Density count ratio

M Count = Moisture counts as read by the gauge

D Count = Density counts as read by the gauge

Figure 3-6 illustrates the terms *void ratio* and *% air voids*. The *void ratio* is the ratio of the volume occupied by air and water in the soil to the volume occupied by solid particles. The term *% air voids* refers to the volume of air voids only as a percentage of the total volume.

The following formulas are used to calculate the *% air voids* and *void ratio* values.

$$\% \text{ AIR VOIDS} = 100 (1 - (V_s/V_t) - (V_w/V_t))$$

where:

V_s = Volume of Soil

V_t = Total Volume

V_w = Volume of Water

or,

$$\% \text{ AIR VOIDS} = 100 (1 - (DD / SG(D_w)) - (M / (D_w)))$$

where:

D_w = Density of Water

SG = Specific Gravity of Soil Particles

DD = Dry Density

M = Moisture

$$\text{VOID RATIO} = \text{Volume of Voids} / \text{Volume of Soil} \\ = (SG(D_w) - DD) / DD$$

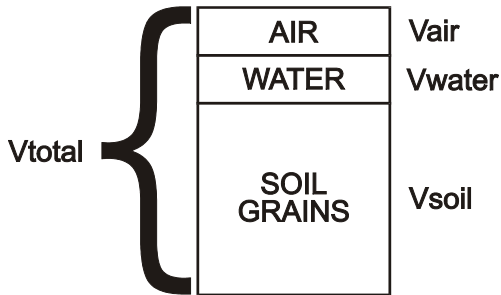

Figure 3-6. Voids Illustration

TAKING A MEASUREMENT – ASPHALT MODE

The *Asphalt* mode is automatically selected when a Marshall value is enabled (see page 3-8).



NOTE

When not taking measurements, always keep the source rod in the SAFE position. For added operator safety, the source rod on the 3430 gauge automatically retracts to the SAFE position when the gauge is picked up by the handle.

If you do not hear a *click* when the source rod is raised to the **SAFE** position, look at the bottom of the gauge to verify that the tungsten sliding block is completely closed. If the gauge base opening is not completely closed by the sliding block, the sliding block may require cleaning. Refer to Appendix C for cleaning instructions.



CAUTION

Do not store or transport the gauge unless the tungsten sliding block is completely closed. Increased radiation levels may violate transportation regulations, and may cause personnel exposure.

Place the gauge over the test site. Release the gauge handle and push it into the backscatter position. Set the depth to *Backscatter*. Ensure that the pin engages the notch in the index rod. Gently tap the handle down to ensure proper source rod seating.

Press **<START/ENTER>**.

Depth: BACKSCAT.
Time: xxx sec.

After the count time has elapsed, the gauge displays the measurement results in a series of six screens, as follows. Use the up and down arrows to scroll through the various screens.

WD: xxxxx	PCF
% MA	xx.x %

DD: xxxxx	PCF
(Use ↑ & ↓ keys)	

Moist: xxxxx	PCF
% Moist:	xx.x %

% VOIDS	xx.x %
100 – % MA	xx.x %

MOIST CR: xx.x
DENS CR: xx.x

M Count: xxxxx
D Count: xxxxx

where:

- WD** = Wet density in kg/m³ or pcf
- % MA** = Percent Marshall (This value is valid only if an appropriate target has been entered for the material being tested.)
- DD** = Dry density in kg/m³ or pcf
- MOIST** = Moisture value in kg/m³ or pcf
- % MOIST** = Percent moisture
- % VOIDS** = $100 (1 - WD/VOIDLESS)$
- 100 – % MA** = Value given by subtracting the percent Marshall value from 100
- MOIST CR** = Moisture count ratio
- DENS. CR** = Density count ratio
- M Count** = Moisture counts as read by the gauge
- D Count** = Density counts as read by the gauge

NOTES

CHAPTER 4

ADVANCED GAUGE OPERATION

This chapter provides instructions for using the Model 3430 Surface Moisture-Density Gauge in special circumstances where the gauge may require an offset or special calibration. This chapter also explains the procedure for using the gauge to measure *thin layers* of asphalt.

CONTENTS

Offsets	4-2
Density Offset	4-3
Moisture Offset	4-4
Trench Offsets	4-6
Special Calibrations	4-7
Entering a New B Value.....	4-8
Gauge-calculated Calibration.....	4-9
Thin Layer Measurements	4-11

OFFSETS

The Model 3430 is factory-calibrated for soils, asphalt, and concrete with an approximate density range of 1100 to 2700 kg/m³ (70 to 170 pcf). With an *offset*, the operator can adjust the gauge readings to correlate to traditional laboratory methods, such as core samples. The 3430 gauge provides three offsets: *density*, *moisture*, and *trench*.

NOTE

When an offset has been enabled, all future readings will automatically be adjusted with the offset factor regardless of the test site. It is very important that the operator disable the offset function prior to taking readings on materials that do not require an offset. Offsets are disabled if the gauge is turned off for more than 10 seconds.

Density offsets are common when the material being measured is outside the range of 70 to 170 pcf (1121 to 2723 kg/m³) or if the material composition varies from average soil/asphalt on which the factory calibration is based.

Moisture offsets are required for accurate measurements if the material to be measured contains elements that can cause the gauge to yield erroneous results. A *negative* offset is required if the material to be measured is high in hydrogenous components such as cement, gypsum, coal, or lime. A *positive* offset is required if the material is high in neutron-absorbing material such as boron or cadmium.

The 3430 gauge requires an offset if measurements are to be taken inside a trench or close to vertical structures. Vertical structures can scatter neutrons and gamma photons back to the gauge, increasing the possibility of moisture or density errors due to high counts.

DENSITY OFFSET

To access the *Special* functions, press **⟨SPECIAL⟩**.

Press the down arrow key once to access the *Offset* function. Press **⟨START/ENTER⟩** to display:

Offset: Density
(↑ ↓ or ENTER)

Press **⟨START/ENTER⟩**.

Dens. Offset OFF
Want to Enable?

To enable the *Density Offset* function, press **⟨ON/YES⟩**.

D off= 0.0 PCF
(↑ ↓ or ENTER)

Input the difference between the gauge and actual density readings. To input a minus sign (for a negative offset), press the down arrow first. To scroll through the numerals, press up and down arrows.

To select the next digit and/or exit, press **⟨START/ENTER⟩**.

The display will be:

Dens. Offset ON

MOISTURE OFFSET

Some soils contain hydrogen sources other than water and/or neutron absorbers. Since the 3430 gauge measures moisture by determining the hydrogen content of the material and relating this to the water content, both types of material could cause gauge readings that differ from the true moisture. If measuring such materials, use a moisture offset to adjust the readings.

The offset factor (k) is determined by comparing the moisture content of a laboratory sample with the moisture content determined by a gauge reading. To determine the offset factor, use the following procedure:

- ✓ Take a gauge reading at the site. Record the reading ($\%M_{GAUGE}$).
- ✓ Remove a sample from the measurement site, then use laboratory methods (for example, oven dry, and so on) to determine the moisture content of the sample ($\%M_{LAB}$). Multiple samples and measurements may be taken. Calculate the average moisture of the samples. This average value should be used for the offset factor calculation.
- ✓ Calculate the offset factor (k).

$$k = \frac{\%M_{LAB} - \%M_{GAUGE}}{100 + \%M_{GAUGE}} \times 1000$$

NOTE

If the k value is negative, a minus sign (–) must be entered by pressing the down arrow before entering the first digit.

To access the *Special* functions, press **<SPECIAL>**.

Press the down arrow key once to access the *Offset* function. Press **⟨START/ENTER⟩** to display:

Offset: Density
(↑ ↓ or ENTER)

To enter a moisture offset, press the down arrow once and press **⟨START/ENTER⟩**.

Moist Offset OFF
Want to enable?

To enable the *Moisture Offset* function, press **⟨ON/YES⟩**.

K= 0.0
(↑ ↓ or ENTER)

The first digit will flash. To input a minus (-) sign (for a negative offset), press the down arrow first! To scroll through the possible values for each digit, press the arrow key. To select the next digit, press **⟨START/ENTER⟩**. When all digits are entered, the gauge will enable the offset. The display will be:

Moist Offset ON

TRENCH OFFSETS

If the Model 3430 gauge is to be used for moisture or density measurements in a trench or within two feet (0.6 m) of a large vertical structure, a trench offset may be required. If used, the trench offset adjusts all moisture measurements but only the density measurements from backscatter through four inches (10 cm).

To perform a trench offset:

- ✓ Take the daily standard count (outside the trench) and record the density count (DS) and moisture count (MS) values.
- ✓ Place the gauge on the reference standard block in the trench the same distance from the wall as the anticipated readings. **Do not take another standard count.**
- ✓ Set the count time to four minutes.
- ✓ With the source rod in the **SAFE** (standard count) position, take a four-minute count. To start the count, press the **<START/ENTER>** key.
- ✓ Record the trench density count (DC_{Trench}) and moisture count (MC_{Trench}).
- ✓ Subtract the daily standard count values from the trench count values:

$$Dens\ Const = (DC_{Trench}) - DS$$

$$Moist\ Const = (MC_{Trench}) - MS$$

To enable a trench offset, choose *Trench* from the *Offset* options under the *Special* functions. The gauge requests the *Dens Const* and *Moist Const* values determined above. The procedure for entering the values is the same as for moisture and density offsets, **ignoring the \pm sign on the display.**

SPECIAL CALIBRATIONS

Troxler gauges are calibrated to “average soil.” Average soil is defined as material consisting of 50% limestone (calcareous) and 50% granite (siliceous). This factory calibration provides accurate results for the majority of materials encountered in the field. However, there are situations when varying material compositions could affect the gauge accuracy. In these special cases the gauge B value can be recalculated either by the gauge or by considering the mass attenuation (μ/ρ) of the material.

If the chemical composition of the soil is known, Troxler can provide a procedure for recalculating the B value for manual entry (see page 4-8) to accurately measure the soil density. This calculation requires in-depth knowledge of the gauge geometry and the detected energy spectrum of the Cs-137 source.

The *Special Calibration* function allows the Model 3430 gauge to be recalibrated for material densities and compositions other than those covered by the factory calibration.

The true density of a sample of the material must be obtained prior to calculating a special calibration. This density may be obtained from a laboratory sample.

To access the *Special* functions, press **<SPECIAL>**.

To access the *Special Calibration* function, press the down arrow four times. Press **<START/ENTER>** to display:

SPECIAL CALIB.
Want to Recalib?

To recalibrate the gauge for the densities outside the factory calibration range, press **<ON/YES>**. To disable the *Special Calibration* feature, press **<OFF/NO>** at the above display and **<ON/YES>** at the disable inquiry. After disabling this feature, the gauge will return to the *Ready* mode.

**SPECIAL CALIB.
Enter B Value?**

To enter a known B value obtained with the procedure available from Troxler, press **<ON/YES>**. To have the gauge calculate the recalibration, press **<OFF/NO>**. If entering a new known B value, see the following explanation. For gauge-calculated special calibration, see page 4-9.

ENTERING A NEW B VALUE

Depth = xx in
(↑ ↓ or ENTER)

To change the value of the flashing digit for the measurement depth, use the up and down arrows. To accept the flashing value and select the next digit, press **<START/ENTER>**.

B VAL = x.xxxx
(↑ ↓ or ENTER)

The gauge displays the current B value. To change the value of the flashing digit, use the up and down arrows. To accept the flashing digit and select the next digit, press **<START/ENTER>**.

Upon entry completion, the gauge will indicate that the special calibration is enabled and return to the *Ready* mode. Note that when the gauge is turned off the *Special Calibration* is disabled.

SPECIAL CALIB.
ENABLED!

GAUGE-CALCULATED CALIBRATION

The true density of the sample and a gauge reading must be performed on the material for the special calibration routine to adjust the gauge calibration.

NOTE

When using destructive methods such as drilling cores or sample removal for true density measurement, take gauge readings before removing samples.

To select the depth and/or exit, press **⟨START/ENTER⟩**.

Depth: xx in.
(↑ ↓ or ENTER)

To scroll through the numerals for the depth of the measurement, press the up and down keys. To select the next field and/or exit, press **⟨START/ENTER⟩**.

If calibration counts have not been taken, the gauge will take four one-minute counts.

The gauge provides the operator with a partial calibration feature. Since a partial calibration allows the operator to enter the density after taking counts, it is helpful to those performing destructive material testing. If the operator has previously taken calibration counts, the gauge asks if these counts should be used in calibrating the gauge. To use the previous counts, press **⟨ON/YES⟩**. The gauge will then request the density. To take new counts, press **⟨OFF/NO⟩**.

Press **START** for
Reading # x

Place the gauge on the test material. To begin taking the four one-minute counts, press **<START/ENTER>**. After each count is complete, the operator must initiate the next count by pressing **<START/ENTER>**.

Enter known
density now?

To create a partial calibration and return to the *Ready* mode, press **<OFF/NO>**. To complete the special calibration by entering the density, press **<ON/YES>**.

Density: xx
(↑ ↓ or ENTER)

To change the value of a digit, press the up and down arrows. To select the next digit, press **<START/ENTER>**. After the density value is entered, the special calibration routine readjusts the gauge for the new material and indicates that the special calibration is enabled. The special calibration is only valid for the depth selected during the special calibration.

**SPECIAL CALIB.
ENABLED!**

THIN LAYER MEASUREMENTS

With the increase in thin lift overlay applications and the limitations of conventional backscatter gauges to measure these overlays the following method (formula) has been developed:

$$DT = \frac{WD - DB \times K}{1 - K}$$

where:

DT = Overlay density

WD = Density read by gauge

DB = Bottom layer density

K = Effect of top layer thickness on the gauge

To use the above method of overlay measurement, follow the procedure below:

- ✓ Determine the density of the bottom layer (underlying material) (***DB***).
- ✓ Apply the thin lift overlay.
- ✓ Determine the thickness of the overlay and select the corresponding (***k***) value from Table 4-1.
- ✓ Measure the thin lift overlay density with the gauge in backscatter position (***WD***).
- ✓ Enter all values into the above equation and calculate the overlay density (***DT***).

EXAMPLE

Given the following values:

$$\text{Bottom Density (DB)} = 135 \text{ pcf (2162 kg/m}^3\text{)}$$

$$\text{Overlay Thickness} = 1.2 \text{ inches (30 mm)}$$

$$K \text{ (from Table 4-1)} = 0.38235$$

$$\text{Density read by gauge (WD)} = 142.0 \text{ pcf (2275 kg/m}^3\text{)}$$

$$DT = \frac{142.0 - (135 \times 0.38235)}{1 - 0.38235}$$

$$DT = 146.3 \text{ pcf}$$

or,

$$DT = \frac{2275 - (2162 \times 0.38235)}{1 - 0.38235}$$

$$DT = 2345 \text{ kg/m}^3$$

NOTE

The majority of the backscattered gamma rays reaching the detectors are the result of interactions in the top 3.3 inches (84 mm) of the overlay. In applications where the overlay thickness is greater than 3.3 inches (84 mm), use (0) for the k value or use the actual gauge readings (WD).

Table 4-1. K Values for Thin Lift Overlays

Thickness (inches)	Thickness (mm)	K
1.0	25	0.46159
	26	0.44787
	27	0.43414
1.1	28	0.42042
	29	0.40138
1.2	30	0.38235
	31	0.36475
	32	0.35889
1.3	33	0.34716
	34	0.33631
	35	0.32547
1.4	36	0.31462
	37	0.29958
1.5	38	0.28454
	39	0.27527
	40	0.26600
1.6	41	0.25673
	42	0.24387
1.7	43	0.23102
	44	0.22310
	45	0.21517
1.8	46	0.20725
	47	0.19626
1.9	48	0.18527
	49	0.17850
	50	0.17172
2.0	51	0.16495
	52	0.15556
2.1	53	0.14617
	54	0.14038

Thickness (inches)	Thickness (mm)	K
	55	0.13459
2.2	56	0.12880
	57	0.12078
2.3	58	0.11275
	59	0.10781
	60	0.10285
2.4	61	0.09790
	62	0.09104
2.5	63	0.08418
	64	0.07995
	65	0.07572
2.6	66	0.07149
	67	0.06562
2.7	68	0.05976
	69	0.05615
	70	0.05253
2.8	71	0.04892
	72	0.04390
2.9	73	0.03889
	74	0.03580
	75	0.03271
3.0	76	0.02962
	77	0.02676
	78	0.02391
3.1	79	0.02105
	80	0.01709
3.2	81	0.01313
	82	0.01069
	83	0.00825
3.3	84	0.00581

ADVANCED OPERATION

NOTES

CHAPTER 5

SPECIAL FUNCTIONS

This chapter gives brief explanations of the *Special* functions available on the Model 3430 Surface Moisture-Density Gauge, or directs the reader to the appropriate section dealing with a particular function.

CONTENTS

Recall	5-2
Offset	5-2
Stat Test	5-2
Drift Test.....	5-5
Special Calibration.....	5-7
Specific Gravity	5-7
Voidless Density	5-8
Set Units.....	5-8
Calibration Constants.....	5-9
Memory Reset.....	5-10
Test Reading	5-10
Language.....	5-11
15-second Inhibit	5-12

RECALL

The *Recall* function allows the operator to view the data from the **last** reading. Even though the 3430 gauge does not store multiple readings, this function displays the latest data.

To access the *Special* functions, press **<SPECIAL>**.

To access the *Recall* feature, press **<START/ENTER>**.

The gauge displays the data from the last measurement. Scroll through the screens using the up and down arrow keys.

OFFSET

For information on offsetting gauge readings, refer to Chapter 4.

STAT TEST

The *statistical stability test*, or *stat test*, may be performed to validate the normal operation of the gauge. Erratic readings or readings that seem to fluctuate may indicate a problem with the gauge. In the event the readings are suspect, a stat test may be executed.

A *stat test* consists of twenty 1-minute counts. After the twenty counts, the gauge calculates the standard deviation. This standard deviation is compared to a theoretical standard deviation value. Ideally this ratio should be one. However, the 3430 gauge pre-scales (or divides) the counts by 16, resulting in an ideal ratio of 0.25. The acceptable limits for the ratio are from 0.17 to 0.33. The gauge is considered to be unstable if the ratio is outside these limits.

To perform a stat test on the 3430 gauge, place the gauge on the reference standard block in the standard count position (see Chapter 3).

To access the *Special* functions, press **⟨SPECIAL⟩**.

To access the *Stat Test* feature, press the down arrow twice and press **⟨START/ENTER⟩**.

press START for
20 min Stat Test

To begin the twenty counts, press **⟨START/ENTER⟩**.

The gauge will display the stat test count progress as shown below.

– STAT TEST –
Rdg.#:xx xx sec

Upon completion of the stat test, the gauge displays the pass/fail status. If the stat test fails, repeat the test twice more. If two out of three stat tests fail, contact Troxler. If the stat test passes, the display is:

D: PASS M: PASS
↑ ↓ to view data

To view the stat test data, use the up and down arrow keys.

Dens. R = xxxx
↑ ↓ to view data

Dens. Avg. xxxx
↑ ↓ to view data

Moist R = xxxx
↑ ↓ to view data

Moist Avg. xxxx
↑ ↓ to view data

•
•
•

#20 D xxxx M xxxx
(Use ↑ & ↓ keys)

DRIFT TEST

If the stat test has already been performed (and passed), but gauge readings seem to drift between tests, the *drift test* can check the long-term drift of the 3430 gauge.

A drift test consists of five 4-minute counts taken approximately 3 to 8 hours after completion of a stat test ***with no movement of the gauge between tests.*** Pass/fail limits are set using the percent difference between the average of the stat and drift test results. If the percent difference exceeds 0.5% for density or 1% for moisture, the drift test fails.

NOTE

The gauge should *not* be turned off between the stat test and drift test. The stat test *must* be current.

In addition, the gauge must not be moved between the stat and drift tests to eliminate possible failure due to positioning changes.

With the gauge still in the standard count position (on the reference standard block), press **⟨SPECIAL⟩**.

From the *Special* functions, select the *Drift Test* feature by pressing the down arrow three times and **⟨START/ENTER⟩**.

press START for
20 min Drift Test

To begin the five counts, press **⟨START/ENTER⟩**.

– DRIFT TEST –
Rdg. #:xx xxx sec

As with the stat test, the gauge indicates the count progress during the drift test.

After the five counts have been completed, the display is:

D: PASS M: PASS
↑ ↓ to view data

To view the stat test data, use the up and down arrow keys.

D% Drift xxxx
↑ ↓ to view data

Dens. Avg. xxxx
↑ ↓ to view data

M% Drift xxxx
↑ ↓ to view data

•
•
•

#5 D xxxx M xxxx
(Use ↑ and ↓ keys)

SPECIAL CALIBRATION

For information on performing a special calibration, see Chapter 4.

SPECIFIC GRAVITY

The specific gravity of a solid is defined as the density of the material divided by the density of water. The *Specific Gravity* function allows the operator to input the specific gravity of a material into the gauge. This value (SG) is used in the calculation of % Air Voids and Void Ratio (see Chapter 3).

To access the *Special* functions, press **<SPECIAL>**.

To access the *Specific Gravity* feature, press the down arrow five times and press **<START/ENTER>**.

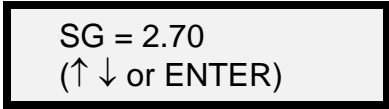

SG = 2.70
(↑ ↓ or ENTER)

To change the value of the flashing digit, use the up and down arrows. To accept the flashing value and select the next digit, press **<START/ENTER>**.

If a value is not entered, the default value is the specific gravity for soil grains (2.70).

VOIDLESS DENSITY

The *Voidless Density* function allows the input of the *theoretical* voidless density value of the material being measured. This value is used in the % Voids calculation.

To access the *Special* functions, press **<SPECIAL>**.

To access the *Voidless Density* feature, press the down arrow six times and press **<START/ENTER>**.

VD = xxx.x
(↑ ↓ or ENTER)

To change the value of the flashing digit, use the up and down arrows. To accept the flashing value and select the next digit, press **<START/ENTER>**.

SET UNITS

For information on the *Set Units* feature, see Chapter 3.

CALIBRATION CONSTANTS

The *Calibration Constants* function allows the operator to change the mathematical constants used for calculating a test result. If the gauge has been repaired or the memory has been lost, the constants **must** be verified or re-entered.

NOTE

Each 3430 gauge contains a unique set of constants. The constants used in one gauge will not work in another gauge! The constants for your 3430 gauge are developed at the factory and are reflected on the factory calibration sheet.

To access the *Special* functions, press **<SPECIAL>**.

To access the *Calibration Constants* feature, press the down arrow key eight times and press **<START/ENTER>**.

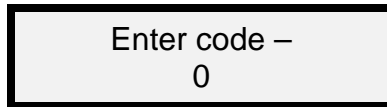

This feature requires the input of the access code found in the front of this manual. Using the up and down arrow keys to select the correct number for the flashing digit, enter the access code. To accept the flashing value and select the next digit, press **<START/ENTER>**.

The gauge will prompt for the input of the *E* value.

NOTE

If the value is negative, enter a minus sign (-) by pressing the down arrow key prior to entering the first digit. Leading zeros must be entered (for example: 0.012345).

To change the value of the flashing digit for the *E* value, use the up and down arrows. To accept the flashing value and select the next digit, press **<START/ENTER>**.

Enter the remaining constants for each depth.

NOTE

If the calibration sheet lists B and F values, instead of B*1000 and F*1000 values, then the calibration is in English, rather than metric, units. Therefore, the B and F values must be converted to metric values and multiplied by 1000 before they are entered into the gauge. A more direct method is to multiply the B and F values by 62.4298, then enter the resulting products into the gauge.

MEMORY RESET

NOTE

This function is for authorized service personnel only!

CAUTION

Memory Reset erases all data stored in the gauge and sets all constants, except calibration constants, to the default values.

TEST READING

NOTE

This function is for authorized service personnel only!

LANGUAGE

The 3430 gauge supports three language displays (English, French, and Spanish). Troxler also offers keypad inserts in each of these three languages (see Appendix C).

To change the display language, first access the *Special* functions by pressing **<SPECIAL>**. Press the up arrow once.

– LANGUAGE –
(↑ ↓ Or ENTER)

To access the *Language* feature, press **<START/ENTER>**.

Enter code –
0

To prevent unauthorized language changes, this feature requires the input of the access code found in the front of this manual. Using the up and down arrow keys to select the correct number for the flashing digit, enter the access code. To accept the flashing value and select the next digit, press **<START/ENTER>**.

English
(↑ ↓ Or ENTER)

To display all gauge operations in English, press **<START/ENTER>**. The gauge returns to the *Ready* mode.

To access either of the other two languages, use the arrow keys. When the desired language is displayed, press **<START/ENTER>**. The gauge returns to the *Ready* mode.

15-SECOND INHIBIT

The *15-second Inhibit* function enables the gauge owner or operator to disable the 15-second count option. When this function is enabled, the 3430 gauge can only conduct one- or four-minute counts.

To disable the 15-second count option, first access the *Special* functions by pressing **<SPECIAL>**. Use the up or down arrows to display:

– 15 SECONDS –
(↑ ↓ Or ENTER)

To access the *15-second Inhibit* function, press **<START/ENTER>**.

Enter Code –
0

This feature requires the input of the access code found in the front of this manual. Using the up and down arrow keys to select the correct number for the flashing digit, enter the access code. To accept the flashing value and select the next digit, press **<START/ENTER>**.

- ▶ If the 15-second count option is currently enabled, the gauge displays:

– 15 SECONDS –
Want to DISABLE?

Press **<ON/YES>** to disable the 15-second count option. The gauge returns to the *Ready* mode.

- ▶ If the 15-second count option is currently disabled, the gauge displays:

– 15 SECONDS –
Want to ENABLE?

Press **<ON/YES>** to enable the 15-second count option. The gauge returns to the *Ready* mode.

APPENDIX A

RADIATION THEORY AND SAFETY

This appendix is required reading for anyone who will operate the Model 3430 Surface Moisture-Density Gauge. This information covers radiation theory, along with a brief explanation of radiation statistics and radiation terminology.

CONTENTS

Radiation Theory	A-2
Atomic Structure	A-2
Radiation Terminology	A-3
Radiation Theory	A-3
Radiation Statistics	A-4
Radiation Safety	A-5
Types of Radiation	A-5
Limiting Exposure	A-5
Monitoring Radiation	A-7
3430 Radiation Profile	A-8
Source Encapsulation	A-11
Emergency Procedures	A-12

RADIATION THEORY

A more detailed discussion of radiological theory can be found in the *Troxler Nuclear Gauge Safety Training Program* manual, provided at the Troxler safety class.

ATOMIC STRUCTURE

All materials consist of chemical elements that can not decompose by ordinary chemical methods. Some examples are:

- (H) Hydrogen (C) Carbon (O) Oxygen
- (U) Uranium (Cf) Californium (Co) Cobalt

Each element contains an atom with a unique structure. The atom consists of protons, neutrons, and electrons (Figure A-1). The protons and neutrons are grouped together in the nucleus. The electrons orbit the nucleus. An atom is normally electrically neutral because the positive charge of the protons cancels out the negative charge of the electrons.

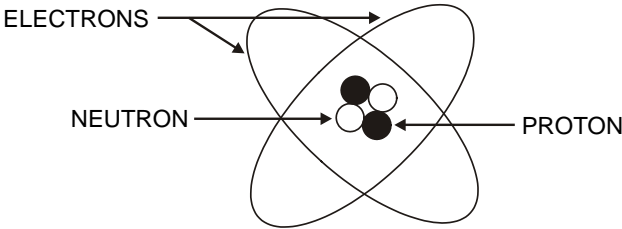

Figure A-1. Diagram of an Atom

Protons carry a positive charge and are described as having a mass of one. Neutrons have no charge and also have a mass of one. Electrons carry a negative charge and essentially have no mass.

MASS (ATOMIC WEIGHT SCALE)	CHARGE
Protons 1.0073	+1
Neutrons 1.0087	0
Electrons 0.0006	-1

Since protons and neutrons are clustered together in the nucleus, the mass of an atom is concentrated in the nucleus. The atom shown in Figure A-1 has two protons and two neutrons; therefore, it is a helium atom. The atomic weight of an atom is the sum of the number of protons and the number of neutrons.

RADIATION TERMINOLOGY

The *curie*, defined as the quantity of radioactive material giving 3.7×10^{10} disintegrations per second, is equal to the number of disintegrations/second of one gram of radium-226. Note that the source used in the 3430 is small, with quantities expressed in *millicurie (mCi)*. The SI unit of radiation is the *becquerel (Bq)*. A becquerel equals one disintegration per second. Therefore, one curie equals 3.7×10^{10} Bq.

The *rad*, or *radiation absorbed dose*, is the unit of absorbed dose equal to 0.01 joules/kg in any medium. To account for the effect of various types of radiation on biological tissue, the *roentgen equivalent man (rem)*, or, more appropriate for Troxler operators, the *millirem* is used when measuring radiation dose. The unit rem is derived by multiplying the radiation absorbed dose (rad) by a quality factor (QF). One *rad* is equal to the exposure of one *rem* of photon radiation. For example, the average neutron energy of an americium-241:beryllium source is approximately 4.5 MeV. The quality factor (QF) for this radiation is about 10. The absorbed dose of 1 rad of neutron radiation gives a dose equivalent (absorbed dose \times QF) of 10 rem (0.1 Sv).

RADIATION THEORY

Radioactivity is the spontaneous breakdown of unstable nuclei (radioisotopes) with the resulting emission of radiation. The strength of radioactive material is measured by its activity, or rate of decay. This activity decreases with time. The length of time it takes a given amount of radioactive material to decay to half of its original strength is referred to as the *half-life*. The half-life of cesium-137 is 30 years, while that of americium-241 is 432 years. Californium-252 has a half-life of 2.6 years.

RADIATION STATISTICS

Radioactive emission is a random process. The number of emissions in a given time period is not constant but varies statistically about an average value. The variation about the true mean value is a Poisson distribution. In this distribution, the standard deviation (σ) about the mean (n) is defined as:

$$\sigma = \sqrt{n}$$

When the mean is greater than 100, the Poisson distribution can be closely approximated by the normal distribution (Figure A-2). The normal distribution predicts the probability that any given count rate will fall within a selected region about the mean.

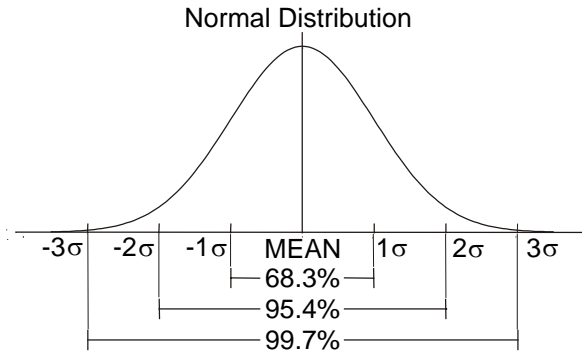

Figure A-2. Variation of Radioactive Emission

Using the average of a large number of counts to approximate the true mean, the distribution shows that 68.3% of the time the count rate obtained will be within ± 1 standard deviation of the mean. Figure A-2 shows the probability of counts falling within three standard deviations of the mean. The operator may perform a statistical stability test (stat test) to compare the experimental standard deviation to the theoretical standard deviation (see Chapter 5).

RADIATION SAFETY

This section provides a brief discussion of general radiation safety. The exposure profile for the Model 3430 gauge is also included, along with a discussion of the source encapsulation.

TYPES OF RADIATION

The radioactive sources in the Model 3430 produce four types of radiation:

- Alpha Particles
- Beta Particles
- Photons (Gamma Rays)
- Neutrons

The alpha and beta particles are stopped by the source capsule. Only the photons and neutrons contribute to any occupational radiation exposure.

Photon (gamma) radiation is electromagnetic radiation, as are x-rays, radio waves, and visible light. Photons have no mass, no electrical charge, and travel at the speed of light. Photons are energetic and penetrating. Dense materials (such as lead, tungsten, and so on) provide the best shielding against photon radiation.

Neutron radiation allows measurement of the hydrogen (water) content in a material because the neutrons are slowed by collisions with materials containing hydrogen atoms (i.e. water, polyethylene, etc). Neutrons have no charge and are very penetrating.

LIMITING EXPOSURE

Government agencies set occupational exposure limits. The current limit in the United States and many other countries is 5,000 mrem per year. Under average conditions, a full-time employee working with the 3430 gauge will receive less than 200 mrem per year. By comparison, people in the US receive an average of 360 mrem per year from natural background radiation and medical radiation.

Taking advantage of all available means to limit radiation exposure is always recommended. The three methods of limiting exposure are:

- Time
- Distance
- Shielding

These methods are a part of the *ALARA* (As Low As Reasonably Achievable) philosophy of radiation protection.

Time

The simplest way to reduce exposure is to keep the time spent around a radioactive source to a minimum. If time is cut in half, then exposure is cut in half, provided all other factors remain constant.

Distance

Distance is another effective means to reduce radiation exposure. A formula known as the *inverse square law* relates the radiation exposure rate to distance (Figure A-3). Doubling the distance from a radiation source reduces the exposure to one-fourth its original value. If the distance is tripled, the exposure is reduced by a factor of nine, and so on.

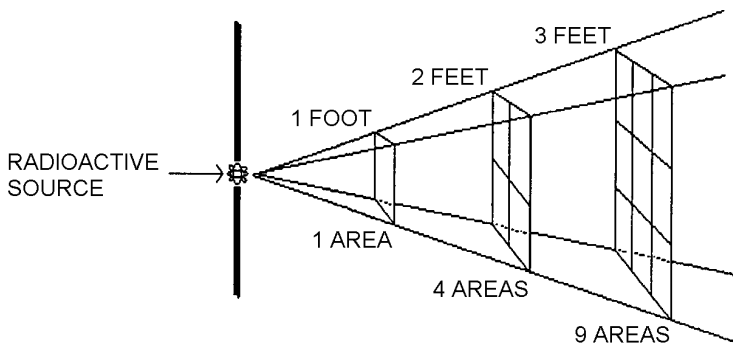

Figure A-3. Effect of Distance on Exposure

Shielding

Shielding is any material used to reduce the radiation reaching the operator from a radioactive source. While some types of radiation (such as alpha particles) may be stopped by a single sheet of paper, other radiation (such as photons and neutrons) require much more shielding. Dense materials, such as lead, shield photons. Materials containing large amounts of hydrogen, such as polyethylene, shield neutrons. The Model 3430 gauge has shielding built into the system to reduce the exposure.

MONITORING RADIATION

In the United States, anyone working with or near radioactive materials is subject to the limits on occupational exposure mentioned earlier and must complete a radiation safety training course to be designated an authorized user. To verify that occupational exposures do not exceed the regulatory limits, authorized users may be monitored using personnel dosimeters. The most common methods of personnel monitoring are thermoluminescent dosimeter (TLD) badges and film badges. Troxler recommends using TLD badges, since they can measure both gamma and neutron radiation. Film badges are not suitable for measuring neutrons.

In Canada, nuclear gauge users are not normally classified as Atomic Radiation Workers. In such cases, the general public dose limit of 0.5 rem per year would apply to nuclear gauge users. Users may not be required to wear a dosimeter. To establish the personnel monitoring requirements for your application, consult the conditions of your radioactive materials license and the Canadian Nuclear Safety Commission (CNSC) regulatory document R91, *Monitoring and Dose Recording for the Individual*.

RADIATION PROFILE

Table A-1 shows the radiation profile for the Model 3430 gauge; Table A-2 shows the profile for the Model 3430-M gauge. Each table lists the radiation dose equivalent rates (in mrem/hour) for each side of the gauge and transport case shown in Figure A-4.

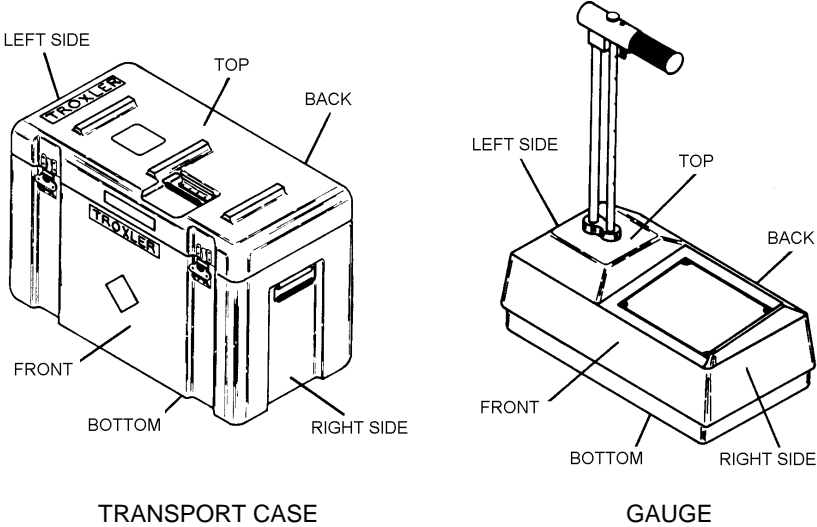

Figure A-4. Model 3430 Gauge and Transport Case

Table A-1. Radiation Profile for Model 3430 Gauge

	SURFACE			10 CENTIMETERS			30 CENTIMETERS			1 METER		
	Gamma	Neutron	Total	Gamma	Neutron	Total	Gamma	Neutron	Total	Gamma	Neutron	Total
GAUGE												
Front	13.0	1.7	14.7	5.0	1.7	6.7	1.1	0.3	1.4	0.3	*	0.3
Back	26.0	1.4	27.4	8.0	1.4	9.4	2.5	0.5	3.0	0.4	*	0.4
Left Side	13.0	0.5	14.0	4.0	0.5	4.5	0.7	0.25	0.95	0.1	*	0.1
Right Side	12.0	0.7	13.0	8.0	0.7	8.7	2.5	0.25	2.75	0.4	*	0.45
Top	19.0	1.7	20.7	8.0	1.7	9.7	0.6	0.7	1.3	0.15	0.1	0.25
Bottom	18.0	6.0	24.0	2.5	6.0	8.5	0.6	0.9	1.5	0.1	0.1	0.2
TRANSPORT CASE WITH GAUGE												
Front	10.0	0.7	10.7	5.0	0.7	5.7	1.2	0.45	1.6	0.25	*	0.25
Back	7.0	0.8	7.8	3.0	0.8	3.8	0.8	0.25	1.1	0.1	*	0.1
Left Side	0.3	0.1	1.4	0.25	0.1	0.35	0.1	0.1	0.2	*	*	*
Right Side	5.0	3.0	8.0	2.0	3.0	5.0	0.6	0.75	1.3	0.2	0.1	0.3
Top	10.0	0.4	10.4	2.5	0.4	2.95	0.6	0.3	0.9	0.1	*	0.1
Bottom	10.0	0.7	10.7	5.0	0.7	5.7	2.0	0.2	2.2	0.3	*	0.3

RADIATION THEORY

NOTES:

1. All readings in mrem/hr.
2. * indicates a reading less than or equal to 0.1 mrem/hr.
3. Gamma measurements made with Ludlum Model 14C Survey Meter, calibrated March 9, 1990.
4. Neutron measurements made with Nuclear Research Corp., Model NP-2 Survey Meter, calibrated March 22, 1990.
5. Dose rates measured by the State of North Carolina Department of Environment, Health, and Natural Resources, Division of Radiation Protection.

Table A-2. Radiation Profile for Model 3430-M Gauge

	SURFACE			30 CENTIMETERS			1 METER		
	Gamma	Neutron	Total	Gamma	Neutron	Total	Gamma	Neutron	Total
GAUGE									
Front	12.0	4.5	16.5	1.5	1.4	2.9	0.3	0.2	0.5
Back	20.0	4.5	24.5	2.0	2.0	4.0	0.4	0.2	0.6
Left Side	13.5	2.0	15.5	3.0	0.8	3.8	0.7	0.2	0.9
Right Side	19.0	1.5	20.5	0.9	0.8	1.7	0.2	*	0.2
Top	18.0	5.0	23.0	0.8	1.8	2.6	0.3	0.2	0.5
Bottom	18.0	16.0	34.0	0.7	3.0	3.7	0.2	0.4	0.6
TRANSPORT CASE WITH GAUGE									
Front	10.0	1.9	11.9	1.4	0.6	2.0	0.3	0.2	0.5
Back	6.0	1.5	7.5	1.2	0.3	1.5	0.2	*	0.2
Left Side	8.0	5.0	13.0	0.8	1.6	2.4	0.2	0.3	0.5
Right Side	0.4	0.2	0.6	*	0.2	0.2	*	*	*
Top	10.0	1.2	11.2	0.9	0.4	1.3	0.2	*	0.2
Bottom	7.0	1.3	8.3	2.5	0.5	3.0	0.6	*	0.6

NOTES:

1. All readings in mrem/hr.
2. * indicates a reading less than or equal to 0.1 mrem/hr.
3. Gamma measurements made with Ludlum Model 14C Survey Meter, calibrated January 7, 1991.
4. Neutron measurements made with Nuclear Research Corp., Model NP-2 Survey Meter, calibrated April 18, 1991.

SOURCE ENCAPSULATION

The source in the Model 3430 gauge meets regulatory requirements of U.S. and international authorities as “Special Form” sealed source material. The sources are encapsulated to prevent leakage of radioactive material and meet radiation safety requirements.

The neutron source (americium-241:beryllium in the Model 3430 or californium-252 in the Model 3430-M) is compressed and then welded inside stainless steel capsules.

The photon (gamma) source (cesium-137) is sealed in a welded capsule.

Proper use of this instrument (following the instructions in this manual) and the shielding design of the instrument will keep the exposure levels at a minimum under normal conditions. The operator may, however, be required to wear personnel dosimetry when using the Model 3430 gauge.

EMERGENCY PROCEDURES

If the nuclear gauge is lost or stolen, then immediately notify the gauge owner's Radiation Safety Officer (RSO).

The gauge owner should complete the emergency contact information on the lines furnished below. (Note that *company* refers to the gauge owner's company, not Troxler Electronic Laboratories.) This information should be readily available to the gauge operator at all times.

The company RSO is _____

Call the RSO at _____

The regulatory agency is _____

Call the agency at _____

If a gauge is damaged, then follow the steps below:

- ✓ Locate the gauge and/or source.
- ✓ Do not touch or move the gauge.
- ✓ Immediately cordon off an area around the nuclear gauge and/or source. A radius of fifteen feet (5 m) will be sufficient. Do not leave the area unattended.
- ✓ Keep all unauthorized personnel from the nuclear gauge.
- ✓ If a vehicle is involved, it must be stopped until the extent of contamination, if any, can be established.
- ✓ The gauge operator should perform a visual inspection of the nuclear gauge to determine if the source housing and/or shielding has been damaged.
- ✓ Use a survey meter to measure the dose rate at a distance of three feet (1 m) from the gauge.

- ✓ Contact the company RSO (name and number given at the beginning of this section). Provide the RSO with the following:
 - ◆ The date, time, and location of the accident
 - ◆ The gauge model and serial number
 - ◆ The nature of the accident
 - ◆ The location and condition of the gauge and/or source
 - ◆ The dose rate at three feet (1 m) from the gauge.
- ✓ If you are unable to reach the RSO, then call your regulatory agency (name and number given at the beginning of this section).
- ✓ Follow the instructions of the RSO. The RSO should report the incident to the regulatory agency. The RSO may also be required to notify the U.S. DOT of accidents during transport.
- ✓ Before shipping a damaged gauge to Troxler, obtain an RGA (Returned Goods Authorization) number from the Troxler RSO as described in the *Returning the Gauge for Service* section of Appendix C.

NOTES

APPENDIX B

3430 SPECIFICATIONS

This appendix contains gauge and measurement specifications for the Model 3430 and Model 3430-M Surface Moisture-Density Gauges.

CONTENTS

Measurement Specifications	B-2
Density at 2000 kg/m ³	B-2
Moisture at 240 kg/m ³	B-2
Density at 125 pcf	B-3
Moisture at 15 pcf	B-3
Radiological Specifications	B-4
Electrical Specifications	B-5
Mechanical Specifications	B-6

MEASUREMENT SPECIFICATIONS

DENSITY AT 2000 KG/M³

Direct Transmission (150 mm)

	<u>.25 min</u>	<u>1 min</u>	<u>4 min</u>
Precision (kg/m ³)	±6.8	±3.40	±1.70
Composition error (kg/m ³)	±20.0	±20.0	±20.0
Surface error (kg/m ³) (100% Void)	-17.0	-17.0	-17.0

Backscatter (98%, 100 mm)

	<u>.25 min</u>	<u>1 min</u>	<u>4 min</u>
Precision (kg/m ³)	±16.0	±8.00	±4.00
Composition error (kg/m ³)	±40.0	±40.0	±40.0
Surface error (kg/m ³) (100% Void)	-75.0	-75.0	-75.0

MOISTURE AT 240 KG/M³

	<u>.25 min</u>	<u>1 min</u>	<u>4 min</u>
Precision (kg/m ³)	±10.3	±5.1	±2.6

Precision is defined as ±one (1) standard deviation in density readings. This number is calculated by the ratio of the standard deviation in the counting rate and the slope of the calibration curve at a given density.

DENSITY AT 125 PCF

Direct Transmission (6 inches)

	<u>.25 min</u>	<u>1 min</u>	<u>4 min</u>
Precision (pcf)	±0.42	±0.21	±0.11
Composition error (pcf)	±1.25	±1.25	±1.25
Surface error (pcf) (100% Void)	-1.06	-1.06	-1.06

Backscatter (98%, 4 inches)

	<u>.25 min</u>	<u>1 min</u>	<u>4 min</u>
Precision (pcf)	±1.00	±0.50	±0.25
Composition error (pcf)	±2.50	±2.50	±2.50
Surface error (pcf) (100% Void)	-4.68	-4.68	-4.68

MOISTURE AT 15 PCF

	<u>.25 min</u>	<u>1 min</u>	<u>4 min</u>
Precision (pcf)	±0.64	±0.32	±0.16

RADIOLOGICAL SPECIFICATIONS

Gamma Source	0.3 ±10% GBq (8 ±10% mCi) cesium-137
Neutron Source	
Model 3430	1.48 ±10% GBq (40 ±10% mCi) americium-241:beryllium
Model 3430-M	2.22 ±10% MBq (60 ±10% µCi) californium-252
Source Type	Sealed Source - Special Form
Source Housing	Stainless Steel
Shielding	Tungsten, Lead and Cadmium
Surface Dose Rate	See Radiation Profiles in Appendix A.
Source Rod Material	Stainless Steel
Shipping Case	DOT 7A, Type A, Yellow II TI. 0.3 (0.6 for Model 3430-M)

ELECTRICAL SPECIFICATIONS

Stored Power	15 watt-hours
Battery Recharge Time	14 to 16 hours
Gauge Charging Requirements	12 V dc, 500 mA minimum
Liquid Crystal Display	2 line x 16 character alphanumeric
Keypad	10-key sealed membrane
Power Consumption	< 0.10 watts average

MECHANICAL SPECIFICATIONS

Base	Cast Aluminum
Gauge Size (w/o handle)	14.45 × 8.85 × 6.45 in 367 × 225 × 164 mm
Gauge Height (w/ handle)	23.25 in (591 mm) for 12" rod 19.25 in (489 mm) for 8" rod
Transportation Case	29.5 × 14.0 × 17.0 in 74.9 × 35.6 × 43.2 cm
Weight	29 lb (13 kg)
Shipping Weight	86 lb (39 kg)
Operating Temperature	Ambient: 14 to 158 °F -10 to 70 °C Surface: 350 °F 175 °C
Storage Temperature	-70 to 185 °F -55 to 85 °C
Vibration Test	0.1 in (2.54 mm) at 12.5 Hz
Drop Test	300 mm onto 25 mm steel ball

APPENDIX C

PERIODIC MAINTENANCE AND SERVICE

This appendix contains information for maintaining and servicing the Model 3430 Surface Moisture-Density Gauge. The following procedures should be performed to keep the 3430 gauge in good working order. If a serious problem with the gauge arises, contact the nearest Troxler Service Center or representative for instructions.

CONTENTS

Troubleshooting	C-2
Possible Malfunction Indicators	C-6
Error Messages	C-7
Battery Charging	C-8
Alkaline Battery Use	C-8
Mechanical Maintenance	C-10
Inspecting the Source Rod	C-10
Cleaning	C-10
Source Rod Bearing	C-11
Tungsten Sliding Block	C-12
Gasket Replacement	C-14
Leak Testing	C-15
Replacement Parts	C-16
Gauge Assembly	C-16
Base Mechanical Assembly	C-18
Source Rod Handle Assembly	C-18
Preamplifier Assembly	C-20
Scaler Assembly	C-22
Other Standard Parts	C-24
Accessories	C-25
Maintenance Supplies	C-25
Returning the Gauge for Service	C-26
Troxler Service Centers	C-28

TROUBLESHOOTING

GAUGE FAILS STANDARD COUNTS

- ✓ Ensure that the source rod opening on the gauge bottom is completely closed or covered by the tungsten sliding block. If any opening is visible, the sliding block should be cleaned as described later in this chapter. If the sliding block still does not close completely, contact the nearest Troxler Service Center.

NO DENSITY READINGS

- ✓ The most likely reason for no density readings is an electronic problem, such as a failure of the detector preamplifier. However, as a precaution, ensure that the tip of the source rod is intact and undamaged (that is, ensure that the source is not missing). Use a radiation survey meter to check the radiation levels on contact with the surface of the gauge base (without extending the source rod). A maximum reading of 10-20 mrem/hr is normal, and indicates the source is present. However, if the maximum reading is less than 1 mrem/hr or if a survey meter is not available, perform a visual inspection of the source rod tip as follows to confirm its integrity:

1. Extend the source rod just far enough to see the source rod tip. The tip should appear flat to slightly rounded and smooth.
2. Stay at least three feet away from the tip of the unshielded source rod and complete the inspection as quickly as possible to minimize exposure (the dose rate at three feet from the unshielded source is about 2.7 mrem/hr).

If the visual inspection indicates that the source rod tip is broken off (source is missing):

1. Immediately contact your Radiation Safety Officer (RSO).
2. Initiate a search for the source starting at the location where the gauge was last used.

3. Report lost or missing radioactive sources to your state or federal radiation control agency in accordance with applicable regulatory requirements.
4. Contact the Troxler Radiation Safety Department for further advice.

GAUGE READINGS APPEAR ERRATIC

- ✓ Ensure that the source rod is properly locked in the desired backscatter or direct transmission position, and is not resting on the test material.
- ✓ Check the inside of the gauge for moisture. To dry the gauge interior, remove the keypad. If necessary, use a hair dryer (on low heat) to circulate warm air for one to three hours.
- ✓ Remove any foreign objects from inside the gauge.
- ✓ Ensure the hardware mounting screws are tight and in place.
- ✓ Check count time – a four-minute count will give the highest precision with a repeatability of ± 1 pcf.
- ✓ Erratic density readings may be caused by a dirty sliding block. Clean the sliding block as described on page C-12.
- ✓ Perform a statistical stability (stat) test.
 - ▶ If test passes, proceed with job.
 - ▶ If test fails, repeat two more times. If test fails two out of three times, contact the nearest Troxler Service Center.

NOTE

To aid in verifying gauge readings, after a gauge has been calibrated, mark a test area on a concrete floor, sidewalk, or equivalent and measure the density (WD). This measurement can then be used as a reference to verify later gauge readings.

GARBAGE OR XXXXXX IS DISPLAYED

- ✓ Check the standard counts in memory. If the standard counts are suspect, perform new standard counts. If counts equal zero for both systems, replace high voltage board (contact the nearest Troxler Service Center).
- ✓ Check gauge for water damage. If the gauge is wet, dry the gauge interior with hairdryer (on low heat) for 3 hours.
- ✓ Check the calibration constants. They should match the constants on your calibration data sheet **if your calibration sheet is in metric units**. (Refer to the note on page 5-10 to determine if your calibration sheet is in metric units and, if not, for instructions on converting B and F values from English to metric units.)
- ✓ If necessary, perform a statistical stability (stat) test, record the results and contact the nearest Troxler Service Center.

GAUGE TURNS OFF AFTER IT IS TURNED ON

- ✓ The gauge automatically turns off after five hours if no keys are pressed. Try to turn the gauge on again.
- ✓ The gauge may be wet. Do not turn the gauge on until moisture is removed from gauge interior! Component damage may result.
- ✓ If the battery is below 3.0 volts, recharge or replace the batteries.
- ✓ The scaler may be defective. To test, replace the suspect scaler with a good scaler.

SHORT BATTERY LIFE AFTER RECHARGING

- ✓ NiCad batteries may be charged up to 100 full charge-discharge cycles. The batteries may be reaching end of life cycle - replace. Note that all information stored in the gauge except the calibration constants and the chosen language is lost when the batteries are disconnected.
- ✓ Charger/adaptor may not be supplying full charge – check the AC outlet and the DC output (12 VDC).

- ✓ Check the output voltage of your charger. The correct output voltage is indicated on the charger unit.
- ✓ Check that you are using the correct charger.
- ✓ Remove any loose screws or foreign objects from the gauge interior that may cause an electrical short to ground.
- ✓ The AC charger may be defective. Check voltage output of charge with a voltmeter, or use the DC charger to charge the batteries.

SATISFACTORY COUNTS, BUT RESULTS ARE IN ERROR

- ✓ Ensure the measurement depth corresponds to the actual source rod depth.
- ✓ Check calibration constants.
- ✓ Check to see if an offset (density, moisture, trench or special) is enabled.
- ✓ Ensure that the standard counts are correct.
- ✓ Ensure that the index rod is seated in bottom of notch.

POSSIBLE MALFUNCTION INDICATORS

CPU Board

Display Malfunctions
No Keypad Response
RAM Test Fails
Batteries Do Not Recharge
Battery Low Indicator Does
Not Function Correctly

Display Test Fails
Gauge Doesn't Turn "Off"
Beeper Stops (or is erratic)
Gauge Does Not Turn On
When Charger Is Connected

Preamp Board

No Moisture or Density Counts
Batteries Do Not Recharge

Gauge Fails Tube Test
Fails Stability or Drift Tests

HV Board

No Moisture or Density Counts
Moisture or Density Counts are
Unstable

Batteries Discharge
Prematurely
Gauge Fails Stability or Drift
Tests

ERROR MESSAGES

The following error messages are not user-serviceable. Contact Troxler Customer Service for more information.

KEY PAD TEST ERROR!

GM TUBE TEST ERROR!

HELIUM TUBE TEST ERROR!

DISPLAY TEST ERROR!

BATTERY CHARGING

With fully charged batteries, the 3430 gauge will remain operational for approximately eight weeks under normal (8-hour day) conditions.

If the batteries become discharged, the following message will be displayed on the gauge:

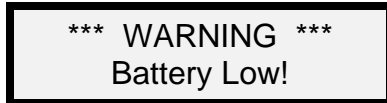

When this display appears, there are a few hours remaining before the battery must be recharged. In an emergency, a 30-minute recharge with the DC or AC charger gives several hours of use.

Although batteries cannot be “overcharged,” rechargeable batteries have a “memory” and repeated unnecessary recharging will shorten the battery life. If possible, run the batteries down before recharging.

NOTE

Batteries should not be recharged unless the Battery Low! indication is displayed!

ALKALINE BATTERY USE



CAUTION

Do not mix alkaline and rechargeable batteries in the gauge. Charging may cause alkaline batteries to explode!

If recharging the NiCad batteries is not an option, alkaline batteries may be used. A separate battery case (PN 104148) can be purchased as an option. Note that all information stored in the gauge except the calibration constants and the chosen language is lost when the batteries are disconnected.

- ✓ Turn the gauge off.
- ✓ Remove the display panel assembly by loosening the four captive screws on the display panel. Disconnect the ribbon cable from the baseboard. The ribbon cable connection is a locking release. To disconnect, push the levers on either side of the ribbon down.
- ✓ Remove the four screws that attach the topshell to the gauge base. Lift the topshell up and secure it to the handle.
- ✓ After noting the polarity of the connection, disconnect the battery pack. The connector is a white plug with red and black wires. Do not remove the connector with the red jumper.
- ✓ Loosen the battery pack screw closest to the baseboard. This screw does not have to be completely removed in order to remove the pack.
- ✓ To remove the battery pack, slide the pack forward and lift up.
- ✓ Replace the battery pack by sliding the optional alkaline battery case beneath the rear screw and washer.
- ✓ Replace the front screw for the battery case.
- ✓ Connect the battery case to the baseboard, observing the correct polarity.
- ✓ Replace the topshell. **Be careful not to over-tighten the screws, and tighten them evenly to prevent warping of the topshell (tighten to about 6 in-lb torque).**
- ✓ Reconnect the ribbon cable to the baseboard assembly and replace the front panel assembly.

MECHANICAL MAINTENANCE

CAUTION

Personnel should wear a dosimeter to monitor radiation exposure while performing maintenance on the gauge.

INSPECTING THE SOURCE ROD

To ensure the integrity of the source rod, Troxler recommends that a qualified Troxler service person inspect the gauge and the source rod at least once every five years. This inspection includes checking for excessive wear, corrosion, or damage that could affect the safe operation of the gauge.

CLEANING

If the 3430 gauge is to provide precise and accurate measurements over a long period of time the gauge should be kept as clean as possible. Monitor the outside surfaces of the instrument for accumulations of dirt, oil, asphalt, or any other foreign matter. If a build-up of material is visible on the gauge base or topshell, use the following procedures for cleaning:

To clean the gauge base, use a putty knife to scrape away any built-up accumulations of soil or asphalt. **Be careful not to damage the gauge base!** After removing any large accumulations, wipe the gauge base with a cloth soaked in WD-40®. The WD-40 should remove the remaining debris.

CAUTION

WD-40 can damage the keypad. Do not allow WD-40 to come in contact with the keypad!

Currently, the 3430 gauge topshell is manufactured from an engineering thermoplastic designed specifically to provide high impact strength and to offer excellent compatibility with many industrial solvents and petrochemicals. The topshell may be cleaned with mild (low alkaline) soap and water. Other approved cleaning substances include methyl, isopropyl, or isobutyl alcohols. A cloth dampened with kerosene or diesel fuel may be used on this topshell

(see following notes) to remove heavy soils. **Avoid prolonged exposure and do not soak.**



CAUTION

The use of any unapproved cleaning agents such as methyl-ethyl-ketones, amines, and methylene chloride will damage the topshell and void the warranty.

NOTE

In the past, the topshell was not compatible with petrochemicals. Your topshell is compatible with petrochemicals only if upon removal of the keypad there is a ridge around the exposed opening. If not, use a mild soap (such as 409™ or Fantastic™) or alcohols (such as methyl or isopropyl.)

SOURCE ROD BEARING

If the source rod does not slide up and down freely, the source rod bearing may require cleaning and lubrication.

- ✓ Carefully remove the gauge topshell and slide it up out of the way. Secure the topshell to the handle.
- ✓ To catch any grease, place a rag or cloth under the vent valve located below the grease fitting on the source rod tower.

NOTE

The vent valve was not installed on earlier gauges. Instead, an Allen-head screw was located beneath the grease fitting. On the gauges, remove the Allen-head screw before applying lubricant to allow the old grease to be ejected. Failure to remove the Allen screw may result in severe mechanical damage to the base assembly.

- ✓ Using a standard 16-ounce grease gun loaded with a Magnalube®-G cartridge, apply five shots of lubricant or enough to eject all dirty grease until clean grease is visible.
- ✓ Re-assemble the gauge. Do not apply more than 6 in-lb torque to the topshell screws.

TUNGSTEN SLIDING BLOCK

If the tungsten sliding block is not kept clean, it may stick partially or completely open when the source rod is raised to the **SAFE** (shielded) position. This will result in high radiation levels near or in line with the source rod opening on the bottom of the gauge. After cleaning and reassembling the gauge as described below, check the operation of the sliding block by pushing the source rod into the backscatter position, then returning it to the **SAFE** position. You should hear a *click* as the sliding block snaps shut. Inspect the opening on the base of the gauge to confirm that the sliding block is completely closed. If not, check that the sliding block spring was properly installed after cleaning. If the sliding block still does not close properly, immediately contact your nearest Troxler Service Center.



CAUTION

Do not store or transport the gauge unless the sliding block is completely closed. Increased radiation levels may violate transportation regulations and cause excessive personnel radiation exposure.

The tungsten sliding block may require cleaning if the source rod becomes difficult to lower into the “measure” position or if a *click* is not heard when the source rod is raised to the **SAFE** position. An improperly operating sliding block may also result in erratic or incorrect density readings and increased radiation levels.

- ✓ With the source rod in the **SAFE** position, place the gauge on its side.
- ✓ Clean the heads of the four screws holding the bottom plate to the gauge base (Figure C-1). Using a screwdriver, remove the four screws and the plate. Replace the plate if excessive wear is evident on the inside surface of the plate.
- ✓ To reduce radiological exposure, stand to one side of the gauge. Paying close attention to the position of the sliding block, remove the block. Clean the block and the cavity with a stiff brush or rag soaked in alcohol or WD-40.

- ✓ Re-install the sliding block with the angled side up. Apply a light coating of Magnalube-G to the top angled surface of the block. Do not apply grease to any other surface on the sliding block or in the sliding block area.
- ✓ Replace the wiper ring in the bottom plate.
- ✓ Re-install the bottom plate. **Do not over-tighten screws!** Ensure that the source rod moves up and down freely.

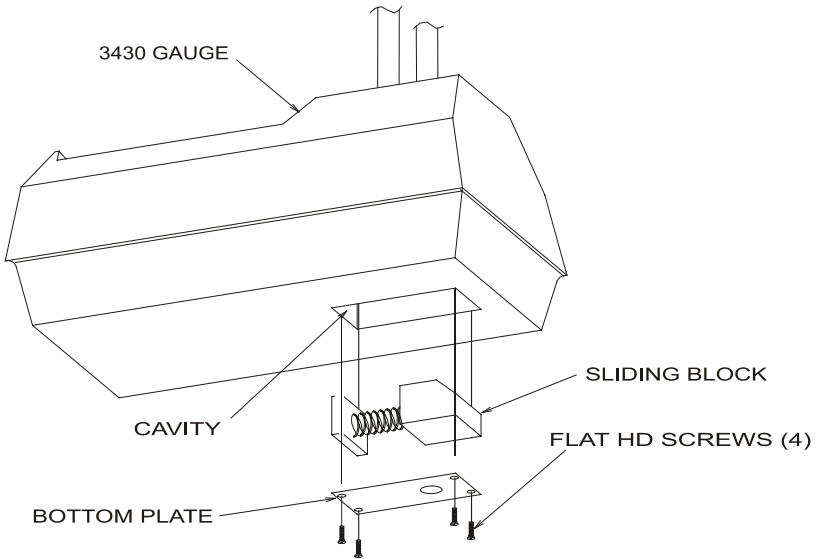

Figure C-1. Removing the Tungsten Sliding Block

GASKET REPLACEMENT

Four gaskets seal the gauge from moisture, dirt, and debris. Condensation may form inside the gauge if the gauge has been out in extremely wet weather or in high humidity, or if it is used in the cold and stored in a warm building. In this case, remove the topshell and allow the gauge to dry. If necessary, use a hairdryer (on low heat) to remove any built-up moisture. If moisture continues to be a problem or debris is present inside the gauge base, the gaskets may need replacing.

To replace the control panel gasket, loosen the four screws in the corners of the panel, and remove the panel from the gauge topshell. Use care in removing the panel and ribbon cable. Gently peel the old gasket from the panel and replace with a new gasket. Replace the connectors and the control panel.

To replace the two post gaskets and the topshell gasket, remove the screws that hold the topshell to the gauge base. Gently peel the gaskets away from the topshell and gauge base and replace. Tighten topshell screws to 6 in-lb.

If replacing the post gaskets, slide them over the source rod. A light coating of talcum powder on the inside of the new post gasket will aid in reassembly.

LEAK TESTING

Unless specified otherwise by your license, the gauge must be leak tested at intervals not exceeding 12 months to ensure the integrity of the radioactive source encapsulation. Sample analysis must be performed by a licensed laboratory only.

Using the Troxler Model 3880 Leak Test Kit and accompanying instructions, perform the following procedure:

NOTE

Ensure that the source rod is in the SAFE position (see Figure 3-2).

- ✓ Write the date, gauge model number, and serial number on the wipe disk.
- ✓ Remove the control panel from the gauge topshell. Locate the yellow radiation label on the top surface of the base.
- ✓ Place two drops of leak test solution on the wipe disk.
- ✓ Holding the wipe disk with the tongs, wipe the radiation label.
- ✓ Turn the gauge on its side and locate the opening where the source rod extends through the gauge base.
- ✓ Holding the wipe disk with tongs, wipe the area around and inside the opening where the source rod extends from the gauge base.
- ✓ Pack the disk, as instructed, in the envelope and mail to Troxler Electronic Laboratories, Inc. for analysis.
- ✓ Secure the gauge properly.

REPLACEMENT PARTS

Figures C-2 through C-6 show the replaceable parts of the Model 3430 gauge.

GAUGE ASSEMBLY

Match the reference number (Ref #) shown below with the correct part in Figure C-2 on the opposite page.

<u>Ref #</u>	<u>Part Number</u>	<u>Description</u>	<u>Qty</u>
1	000001.0601	Washer #6 INT Lock SS	4
2	106368	3430 Gauge Gasket (topshell to base)	1
3	105299	3430/3440 Preamplifier Assembly	1
4	106340	Gasket, Depth Strip Hole	1
5	104149	3430 Battery Assembly (w/case)	1
6	105298	High Voltage Cover Box	1
7	100989	Gasket-Molded for Base Post	1
8	106068	3430 Topshell	1
9	105300	3430 Nameplate	1
10	104122	Radiation Label	1
11	000900.0621	Screw, #4 (.114 Dia.) x 3/16" Drive	8
12	000310.4891	Screw, 6-32 x 5/8 SHCS w/ Insert	4
13	105301	3430 Front Panel Assembly	1
14	102662	Scaler Label (3401-3411)	1
15	101603.1010	Roll Pin, 3/32 D X 5/8 L (Index Rod Top)	1
16	106367	Gasket, Flat Tower (do not use on old topshell)	1
17	018128.0001	Loctite, 290 Wick & Seal	
18	102096	3400 Cap Screw	1
19	102103	Cap Screw Bumper	1

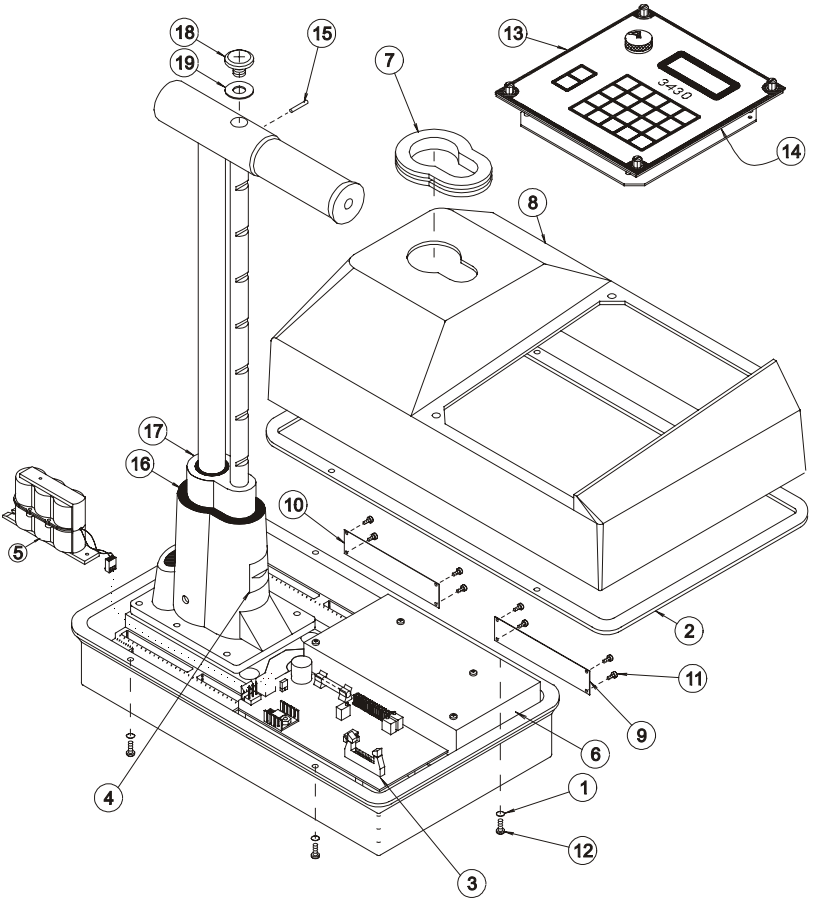

Figure C-2. 3430 Gauge Assembly

BASE MECHANICAL ASSEMBLY

Match the reference number (Ref #) shown below with the correct part in Figure C-3 on the opposite page.

<u>Ref #</u>	<u>Part Number</u>	<u>Description</u>	<u>Qty</u>
1	105256	3400 Base Machining	1
2	100996	3400 Sliding Block	1
3	102351	3400 Round Bioshield	1
4	105264	Bottom Plate Assembly	1
5	102069.1000	Wiper Cap	1
6	104594	Source Rod Bearing (2 required)	2
7	102130	Source Plug 3200/3400	1
8	102399	Shield Spring 3400	1
9	000608.1101	Screw, 10-32 x 1/2 FHMS Phil SS	4
10	012752	Seal, Wiper	1
11	012759	Seal, Oil ID 5/8" ID	2
12	013200	Fitting, 3/16 Grease w/ Serrated Shank Alemite #1728B	1
13	001006.4090	Screw, 5/16-18 x 3/8 Set Screw	3
14	101603.0510	3/32 Dia. x 5/16 L. Roll Pin	2
15	012789	Lubricant, Magnalube-G 14.5 oz	
16	105239	Baseplate Gasket	1
17	018127.0001	Loctite, 242	
18	105309	Spring Guide	1

SOURCE ROD HANDLE ASSEMBLY

Match the reference number (Ref #) shown below with the correct part in Figure C-4 on the opposite page.

<u>Ref #</u>	<u>Part Number</u>	<u>Description</u>	<u>Qty</u>
1	105190	Gauge Handle	1
2	104553	Plunger 3400	1
3	105108	Trigger	1
4	012200	Spring (for trigger)	1
5	101604.1610	Roll Pin, 1/8 Dia. x 1"	1
6	012779.3000	Plug, Heyco Cap. #2643, Black	1
7	000824.4800	Screw, 1/4-20 x 1-1/2 Soc. HD Cap	1

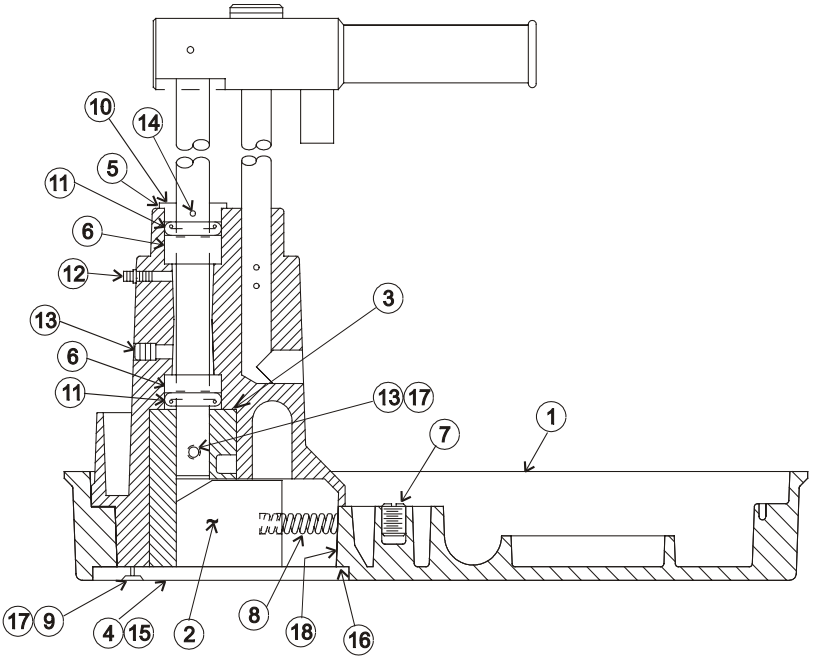

Figure C-3. 3430 Gauge Base Mechanical Assembly

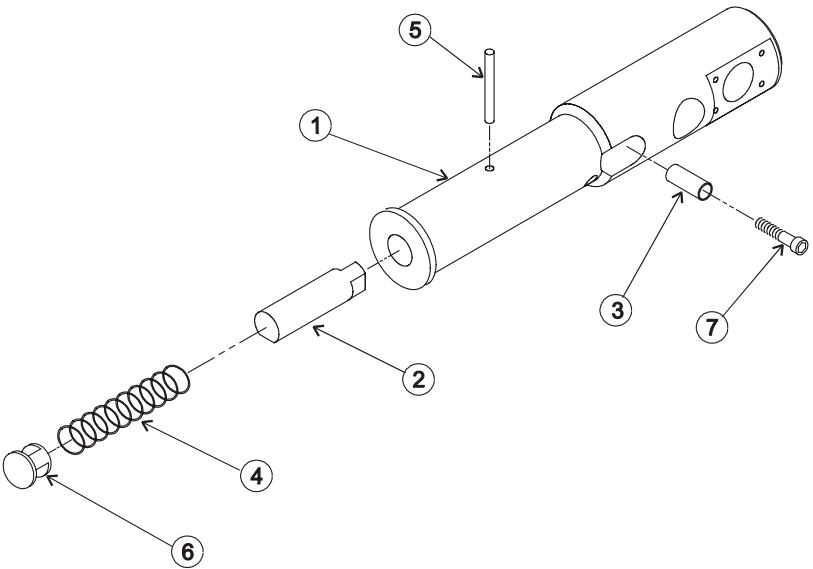

Figure C-4. 3430 Source Rod Handle Assembly

PREAMPLIFIER ASSEMBLY

Match the reference number (Ref #) shown below with the correct part in Figure C-5 on the opposite page.

<u>Ref #</u>	<u>Part Number</u>	<u>Description</u>	<u>Qty</u>
1	105726	3440, 3430 Assembly, HV Baseboard	1
2	105771	Assembly 3430, 3440 Pre-amp PC BD	1
3	000923.3252	Spacer, 4-40 x 1" Hex M/F Threaded	4
4	018127.0002	Loctite, 242 Medium Strength	
5	105289	3430, 3440 Preamplifier Mech Assembly	1
6	104136	Interface PC Board Bracket	1
7	000206.1400	Screw, 4-40 x 3/8 PHMS Phil	2
8	104098	GM Tube Interface PC Board	1
9	100156	Geiger-Mueller (GM) Tube	2
10	000001.1001	Washer, #10 Int. Lock SS	1
11	000204.1400	Screw, 4-40 x 1/4" PHMS Phil SS	7
12	000001.0401	Washer, #4 Int. Lock SS	7
13	104094.0001	900 VDC Moisture Tube Assembly (He-31 Tube)	1
14	000001.0601	Washer, #6 Int. Lock SS	6
15	000306.1401	Screw, 6-32 x 3/8 PHMS Phil SS	2
16	104137	GM Tube Holder	1
17	103540	Modified Tube Clamp	1
18	000604.1400	Screw, 10-32 x 1/4 PHMS Phil	1

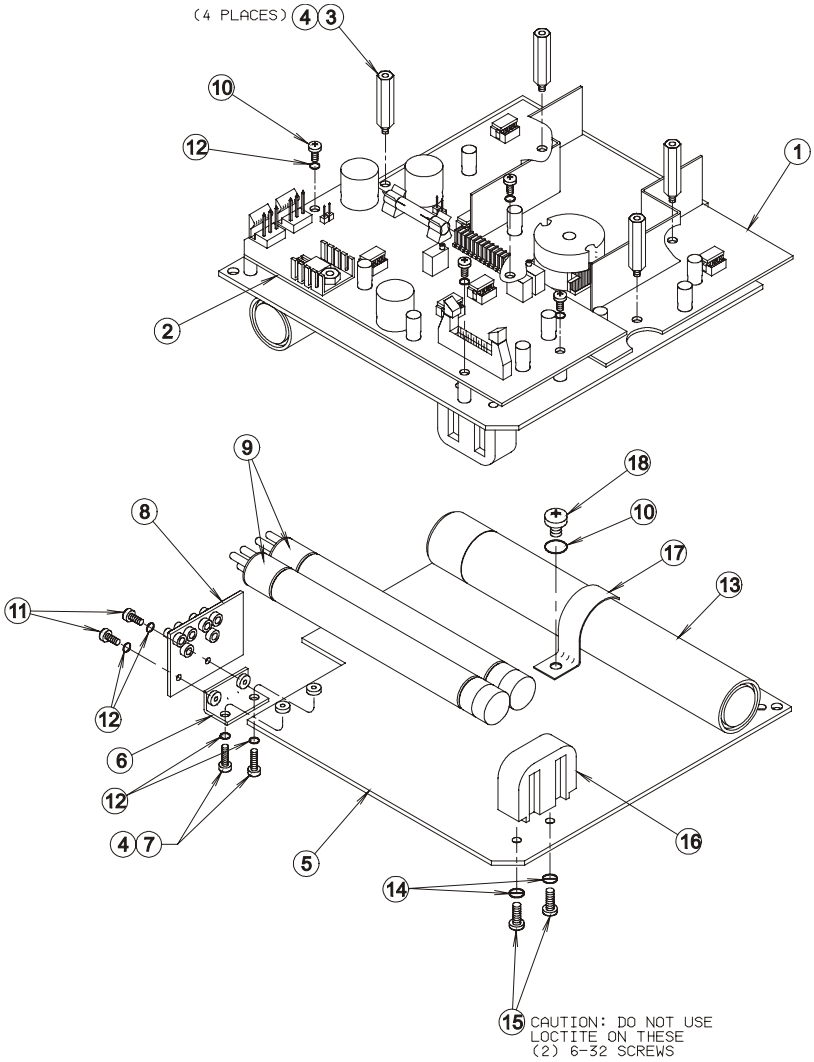

Figure C-5. 3430 Gauge Preamp Assembly

SCALER ASSEMBLY

Match the reference number (Ref #) shown below with the correct part in Figure C-6 on the opposite page.

<u>Ref #</u>	<u>Part Number</u>	<u>Description</u>	<u>Qty</u>
1	105291	Charger Well	1
2	106819	3430 Overlay-w/inserts	1
3	105287	Front Panel 3430	1
4	106369	Front Panel Gasket	1
5	105832	PCB, Assembly, 3430 CPU	1
6	105294	Washer	2
7	102888	Cable, 3400B (front panel to base)	1
8	105295	Nut	1
9	106525	Assembly, Metal Cap w/lug	1
10	000001.0401	Washer, #4 Int. Lock SS	5
11	000204.1400	Screw, 4-40 x 1/4" PHMS Phil SS	4
12	000202.1400	Screw 4-40 x 1/8 PHMS Phil SZP	1
13	106856	Grounding Clamp	1
14	000204.2408	4.40 x 1/4 PHMS Slotted Nylon	1
15	000012.0406	# 4 Flat Washer Nylon	1

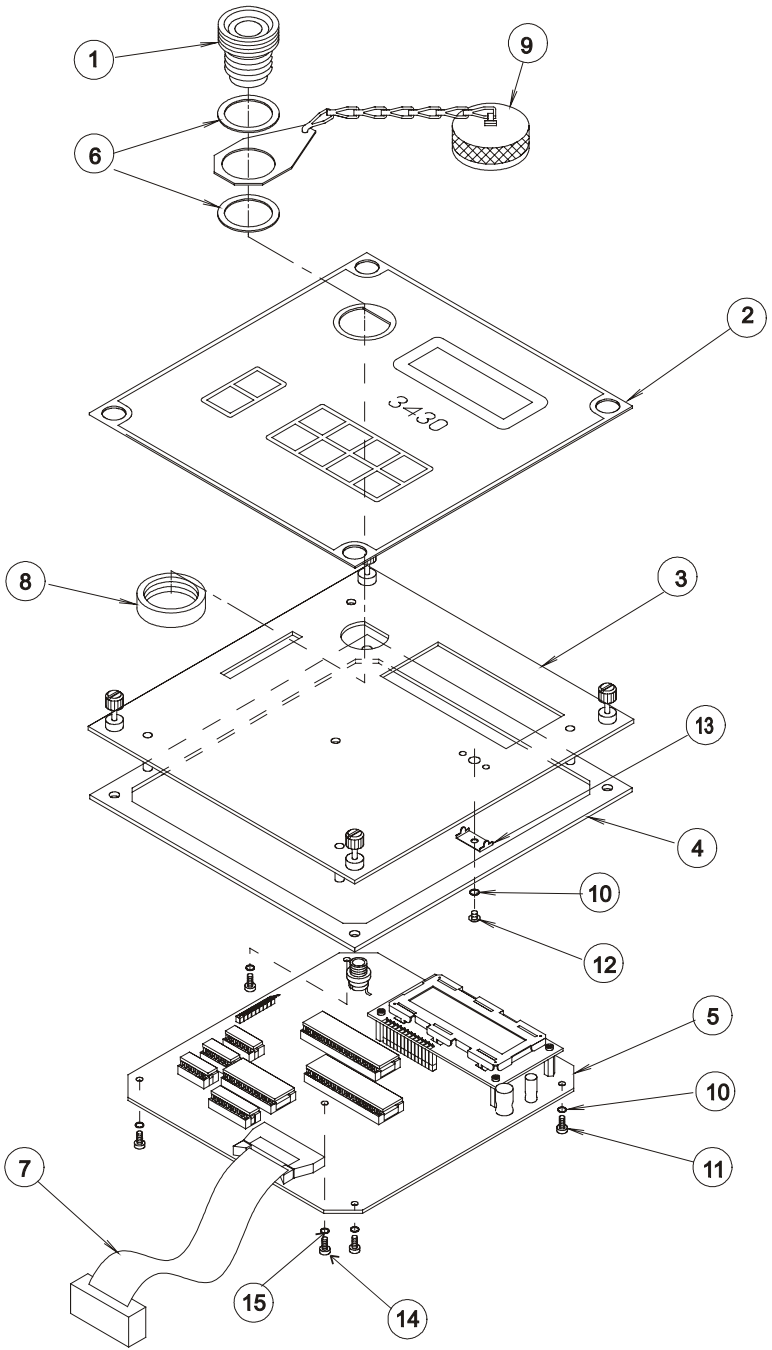

Figure C-6. 3430 Gauge Scaler Assembly

OTHER STANDARD PARTS

The following standard parts are not shown in Figures C-2 through C-6:

<u>Part Number</u>	<u>Description</u>
106852.0001	Kit, 3430 Language Mod, French (Overlay)
106852.0003	Kit, 3430 Language Mod, Spanish (Overlay)
106852.0004	Kit, 3430 Language Mod, Chinese (Mainland Overlay)
106852.0005	Kit, 3430 Language Mod, Chinese (Taiwan Overlay)
107472	LCD Display
012751	Seal, (for Bearing T. S-625)
012754	Ring Scraper
012753	Ring Retaining (for scraper ring)
012176	Lock with 2 Keys (handle)
104305	Handle Sleeve
100528.2000	Screw, Captive (for Battery Pack)
002507	Charger Jack PC MT
016247	Fuse 2A 3AG
104149	Battery Pack Assembly

ACCESSORIES

The following accessories are not shown in Figures C-2 through C-6:

<u>Part Number</u>	<u>Description</u>
104148	Accessory Battery Case Assembly
104410	AC Charger, 12 V dc, 500 mA (Domestic)
104155	AC Charger, 13.6 V dc, 500 mA (International)
108354	AC Adapter, 12 V dc, CE International
104156	DC Charger
102868	Leak Test Kit w/ 4 packets
102876.0005	Leak Test Packet (4 unit refill)
102873	1 oz Solution Detergent (leak test)
109661	Survey Meter
021140	Radiation sign kit
105305	3430 Operator Manual English
105305.0001	3430 Operator Manual French
105305.0003	3430 Operator Manual Spanish
105305.0004	3430 Operator Manual Chinese-Mainland
105305.0005	3430 Operator Manual Chinese-Taiwan
100421	Drill Rod
102111	3400 Scraper Plate (Drill Rod Guide)
103484	Standard Assembly (3400) (Reference Standard Block)
103680.1000	Extraction Tool
103623.3440	3430 Shipping Case/Carton Assembly
106875.0002	Concrete Adapter 3400 2" w/ Accessories
106875.0004	Concrete Adapter 3400 4" w/ Accessories
106875.0008	Concrete Adapter 3400 8" w/ Accessories
106875.0010	Concrete Adapter 3400 10" w/ Accessories

MAINTENANCE SUPPLIES

The following maintenance supplies are not shown in Figures C-2 through C-6:

<u>Part Number</u>	<u>Description</u>
012784	Lubricant, Magnalube-G paste 1.5 oz tube
012786	Lubricant, Magnalube-G paste 1 lb can
012789	Lubricant, Magnalube-G 14.5 oz
100761	Source rod pig

RETURNING THE GAUGE FOR SERVICE

All shipments within the U.S. to the factory must comply with 49 CFR (see Appendix D) and must be accompanied by an RGA (Returned Goods Authorization) number. This will provide information to shipping and service personnel for expediting the repair work. Please call or fax the factory or branch office to obtain the RGA number.

NOTE

**When you contact Troxler for an RGA number, you will be given shipping instructions that will save you considerable time and money.*
Please ask for special 2-day air shipment rates.**

Please have the following information available when calling:

- ◆ System model and serial number.
 - ◆ Part number/serial number (if applicable).
 - ◆ Is system still under warranty?
 - ◆ Problem or difficulty you are having with the instrument.
 - ◆ Shipment method to Troxler and for return shipment.
 - ◆ Shipping and billing address (not PO Box) - street address and zip.
 - ◆ Phone number and contact (for questions from Troxler).
 - ◆ Will estimate be required prior to performing any work on the system?
 - ◆ Purchase Order Number. All Government Agencies (city, county, state and federal) must send purchase order numbers.
- * **Special offers may be discontinued at any time without prior notice.**

NOTE

To prevent order duplication, if an order has been placed by telephone, please write “Confirming Order” on any follow-up written requests.

NOTE

Returning a 3430 gauge requires special handling and shipping procedures. Follow the instructions in Appendix D. Please contact a Troxler Sales Support or Service Representative with any questions.

TROXLER SERVICE CENTERS

Troxler Corporate Headquarters

3008 Cornwallis Road
P.O. Box 12057
Research Triangle Park, NC 27709
Phone: 1.877.TROXLER (1.877.876.9537)
Outside the U.S.A.: +1.919.549.8661
Fax: +1.919.549.0761
Web: www.troxlerlabs.com

Technical Support

Phone: 1.877.TROXLER (1.877.876.9537)
E-mail: TroxTechSupport@troxlerlabs.com

Midwestern Branch Office

1430 Brook Drive
Downers Grove, IL 60515
Fax: 630.261.9341

Florida Service Center

2376 Forsyth Road
Orlando, FL 32807
Fax: 407.681.3188

Western Regional Branch Office

11300 Sanders Drive, Suite 7
Rancho Cordova, CA 95742
Fax: 916.631.0541

Troxler European Subsidiary

Troxler Electronics GmbH
Gilchinger Strasse 33
D.82239 Alling nr. Munich, Germany
Phone: ++49.8141.71063
Fax: ++49.8141.80731
E-mail: troxler@t-online.de

Southwestern Branch Office

2016 East Randol Mill Road
Suite 406
Arlington, TX 76011
Fax: 817.275.8562

NOTE

To locate an independent, Troxler-authorized service center near you, call 1.877.TROXLER (1.877.876.9537).

APPENDIX D**TRANSPORTATION AND SHIPPING**

Devices containing radioactive materials must be transported in accordance with the rules of the U.S. Department of Transportation (DOT) and the International Atomic Energy Agency (IAEA). The IAEA recommendations have been codified in the International Air Transport Association (IATA) Dangerous Goods Regulations. International customers should consult their local government or licensing authority for applicable regulations.

CONTENTS

U.S. Shipping Requirements.....	D-2
Accident Notification Requirements.....	D-3
Hazmat Training.....	D-3
Canadian Shipping Requirements.....	D-4

U.S. SHIPPING REQUIREMENTS

The U.S. DOT hazmat regulations (49 CFR, Parts 100–185) apply any time a nuclear device is transported by motor vehicle on a public highway or by other means of transport (rail, air, ship).

The major requirements for transporting a nuclear gauge in the United States are listed below. For more detailed information about these requirements, please refer to the *Troxler Transportation Guide*.

- ◆ A copy of the current IAEA Certificate of Competent Authority for each source in the gauge (Special Form Certificate) must be kept on file. Current versions can be downloaded from the Troxler website, www.troxlerlabs.com.
- ◆ A copy of the results of the Type A package testing must be kept on file.
- ◆ Hazmat employee training records must be kept on file.
- ◆ An *Emergency Response Information* document must be in the vehicle and immediately accessible to the driver.
- ◆ A properly completed bill of lading must be in the vehicle and immediately accessible to the driver. The shipping papers must include a 24-hr emergency response phone number.
- ◆ If shipping by air, a *Shipper's Declaration for Dangerous Goods* must accompany the air waybill.
- ◆ The package must be properly marked and labeled in accordance with hazmat regulations.
- ◆ The package must have a tamper-evident seal.
- ◆ The package must be inspected prior to each shipment.
- ◆ The package must be securely blocked and braced in the vehicle to prevent shifting during transport.

Accident Notification Requirements

In the event of a reportable incident involving radioactive material, notify the licensing agency as soon as practical. The operator is also required to notify, at the earliest practical moment, the U.S. DOT at 1-800-424-8802 of an accident that occurs during the course of transportation (including loading, unloading, and temporary storage) in which fire, breakage, spillage, or suspected contamination occurs involving shipment of radioactive materials.

Hazmat Training

The U.S. DOT regulations require every hazmat employer to train, test, certify, and maintain records for each hazmat employee. Hazmat training applies to anyone who transports or prepares for transport radioactive materials. Refresher training is required every three years.

CANADIAN SHIPPING REQUIREMENTS

The *Transportation of Dangerous Goods Act and Regulations* (TDG) and *Transport Packaging of Radioactive Materials Regulations* (TPRM) apply any time a nuclear device used in commerce is transported by any means in Canada.

For training and accident notification requirements, consult the *Transportation Of Dangerous Goods Regulations*. For further information on transporting a nuclear device, contact the transportation section of The Canadian Nuclear Safety Commission (CNSC).

APPENDIX E
STANDARD COUNT LOG

Use the form in this appendix as a guide when recording the daily standard counts. To verify gauge stability, compare the daily standard count to the average of the last four recorded standard counts.

STANDARD COUNT LOG

APPENDIX F

UNIT CONVERSION

The 3430 (3430-M) gauge can display measurement results in either SI (metric) units or English units. Also, HM-181 of 49 CFR changes the standard units of radioactivity in the United States from the English unit of *curies (Ci)* to the SI unit of *becquerel (Bq)*. This requires the shipper to convert the activity on the Bill of Lading from curies to becquerels (GBq). Until everyone is accustomed to the SI units, it is permitted to follow the SI units with the English units in parentheses to clarify the description [for example: 1.48 GBq (40 mCi)].

To help our users convert from English units to SI units, the table in this appendix provides SI conversion factors for common English units relevant to the 3430 (3430-M) gauge.

CONTENTS

Measurement Units	F-2
Radiological Units	F-2

MEASUREMENT UNITS

1 in = 25.4 mm
1 in = 2.54 cm

1 ft = 30.48 cm
1 ft = 0.3048 m

1 pcf = 16.02 kg/m³
1 pcf = 1.6 × 10⁻² g/cm³

RADIOLOGICAL UNITS

1 rem = 0.01 Sv

1 Ci = 37 GBq
1 mCi = 37 MBq
1 μCi = 37 kBq

The following table is provided to assist the operator in converting from millicuries to gigabequerels:

<u>μCi</u>	to	<u>MBq</u>
60.....		2.22

<u>mCi</u>	to	<u>GBq</u>
8.0.....		0.30
40.....		1.48

INDEX

A

Access Code.....	xi
Accessories	1-4, C-25
Accident notification	D-5
Advanced operation	4-1
Alkaline batteries	C-8
Americium-241:beryllium	2-1, 2-5, A-3, A-11, B-4
Asphalt mode	3-17
ASTM standards	1-2
Atomic structure	A-2

B

Backscatter	
Geometry	2-3
Mode	2-2
Base mechanical assembly.....	C-18
Battery	
Alkaline use.....	C-8
Charging	C-8
Bequerel.....	A-3

C

Calibration	
Constants	5-9
Special	4-7
Californium-252	2-5, A-3, A-11, B-4
Case, transport	1-4, A-8
Centers, service.....	iii, C-28
Cesium-137	2-1, 2-2, A-3, A-11
Charging, battery	C-8
Cleaning.....	C-10
Count	
Standard.....	3-10
Time	3-8
View	5-2
Curie	A-3

D

Density	
Measurement theory	2-2
Offset	4-2, 4-3
Voidless	5-8
Depth	
Function	3-8
Setting	3-8
Direct transmission	
Geometry	2-3
Mode	2-2
Display languages.....	5-11
Dosimetry	A-7, A-11
Drift test.....	5-5

E

Effect of top layer.....	4-11
Electrical specifications.....	B-5
Emergency response	
Information	D-2
Telephone number	D-3
Encapsulation	A-11

G

Gasket replacement	C-14
Gauge	
Assembly	C-16
Geometry	2-3
Position	3-4
Size	B-6
Geiger-Mueller (G-M) tubes	2-2
Geometry, gauge	2-3

H

Handle	
Assembly, source rod.....	C-18
Positions.....	3-4

I	
Index rod positions	3-4
Inhibit, 15-second	5-12

K	
Keypad	3-2

L	
Language, display	5-11
Leak testing	C-15
Limits, stat test	5-2
Log, standard count	E-1

M	
Maintenance	
Gasket	C-14
Mechanical	C-10
Sliding block	C-12
Source rod bearing	C-11
Supplies	C-25
Malfunction indicators	C-6
Marshall value, entering	3-8
Marshall/Proctor (MA/PR) Mode	3-8
mCi	A-3
Measurement	
Asphalt mode	3-17
Converting units	F-1
Mode	3-8
Position	3-4
Site, asphalt	3-14
Site, soils and base courses	3-12
Soil mode	3-15
Specifications	B-2
Taking, asphalt	3-17
Taking, soils and base courses	3-15
Theory	2-1
Thin layer	4-11

Mechanical	
Maintenance.....	C-10
Specifications.....	B-6
Memory reset.....	5-10
Mode.....	3-8
Backscatter.....	2-2
Direct transmission	2-2
Selection.....	3-8
Moisture	
In the gauge.....	C-3, C-4, C-14
Offset	4-2, 4-4
Moisture measurement theory	2-5

O

Offset.....	4-2
Density	4-2, 4-3
Moisture	4-2, 4-4
Trench	4-2, 4-6
Operation	
Advanced	4-1
General.....	3-1
Special functions.....	5-1
Temperature	B-6
Theory.....	2-1
Optional equipment	C-25

P

Parameter setup	3-7
Parts	
Gauge	1-4
Replacement.....	C-16
Position	
Safe	3-4
Source Rod.....	3-4
Preamplifier assembly	C-20
Proctor, entering	3-8

Q

Quantity, source.....	B-4
-----------------------	-----

R

Rad.....	A-3
Radiation	
Converting units	F-1
Profile, 3430	A-8, A-9
Profile, 3430-M	A-8, A-10
Safety.....	A-5
Specifications	B-4
Statistics	A-4
Terminology	A-3
Theory	A-2, A-3
Types	A-5
Reading	
Asphalt	3-17
Soils and base courses	3-15
Recall	5-2
Reference standard block.....	1-4, 3-10, 5-3
Replacement	
Gaskets	C-14
Parts.....	C-16
Returning the gauge for service	C-26

S

Safe position	3-4
Scaler assembly	C-22
Self-test	3-6
Service	C-26
Centers.....	iii, C-28
Returning the gauge for.....	C-26
Setup, parameters.....	3-7
Shipping	1-6
Regulations.....	D-2
Weight	B-6
Site, measurement	
Asphalt	3-17
Soils and base courses	3-15

Size, gauge	B-6
Sliding block maintenance	C-12
Source quantity	B-4
Source rod	
Bearing maintenance.....	C-11
Handle assembly	C-18
Positions.....	3-4
Special calibration	4-7
Entering B value	4-8
Gauge-calculated	4-9
Special functions	4-1, 5-1
Specific gravity.....	5-7
Specifications	B-1
Electrical	B-5
Measurement.....	B-2
Mechanical.....	B-6
Radiological.....	B-4
Standard count.....	3-10
Log.....	E-1
Standards, ASTM.....	1-2
Stat test	5-2
Limits	5-2
STD function	3-3, 3-10
Storage site	1-7

T

Temperature, operating	B-6
Test reading	5-10
Theory	
Density measurement.....	2-2
Moisture measurement.....	2-5
Thermoluminescent dosimeter (TLD).....	A-7
Thin layer measurement	4-11
Time function	3-8
TLD	A-7
Top layer effect	4-11
Training, Hazmat.....	D-3
Transport case.....	1-4, A-8

Transportation regulations	D-2
Trench offset	4-2, 4-6
Troubleshooting	C-2
Tungsten sliding block maintenance.....	C-12

U, V, W

Units.....	3-7
Converting.....	F-1
Unpacking and inspection.....	1-6
Viewing data.....	5-2
Voidless density.....	5-8
Weight.....	B-6

NOTES

NOTES

WARRANTY

TROXLER ELECTRONIC LABORATORIES, INC.

LIMITED WARRANTY

TROXLER ELECTRONIC LABORATORIES, INC., and subsidiary, TROXLER INTERNATIONAL, LTD., hereinafter referred to as "TROXLER," warrants this instrument, Model 3430, Serial Number _____, against defects in material and workmanship for a period of twelve (12) months from date of shipment. For gauges sold through authorized TROXLER representatives, the date of shipment will be as of the transfer from representative to purchaser. During the applicable warranty period, TROXLER's obligation under this warranty shall be limited exclusively to the repair at no charge, except for shipping to and from TROXLER'S plant, of any instrument which may prove defective under normal use and which TROXLER's examination shall disclose to its satisfaction to be thus defective. Normal use is defined for the purpose of this warranty as operation under normal load, usage, and conditions with proper care and maintenance and competent supervision. In no event shall TROXLER be held liable for damages, delays, or losses consequential, incidental, or otherwise attributable to the failure of this instrument. TROXLER's liability being specifically limited to repair as stated hereinabove. This warranty is automatically initiated except where modified by contractual or other written and signed agreement.

THERE ARE NO WARRANTIES WHICH EXTEND BEYOND THE DESCRIPTION ON THE FACE HEREOF, AND THIS WARRANTY IS EXPRESSLY IN LIEU OF ALL OTHER WARRANTIES, EXPRESSED OR IMPLIED, AND TROXLER NEITHER ASSUMES, NOR AUTHORIZES ANYONE TO ASSUME FOR IT ANY OTHER LIABILITY IN CONNECTION WITH THE SALE OF THE INSTRUMENT. THIS WARRANTY SHALL NOT APPLY TO THE INSTRUMENT OR ANY PART WHICH HAS BEEN SUBJECTED TO DAMAGE BY ACCIDENT, NEGLIGENCE, ALTERATION, ABUSE, MISUSE, OR SERVICE NOT AUTHORIZED IN WRITING BY TROXLER. SUCH DAMAGE TO INCLUDE BUT NOT BE LIMITED TO BURNING OF CIRCUIT BOARDS AND HARNESS FROM IMPROPER SOLDERING TECHNIQUES AND DAMAGE TO THE INSTRUMENT DUE TO PURCHASER'S FAILURE TO PERFORM MAINTENANCE AS OUTLINED IN THE AUTHORIZED OPERATOR'S MANUAL. DUE TO THE NATURE OF THEIR USE, MECHANICAL ACCESSORY PARTS AND BATTERIES ARE WARRANTED FOR NINETY (90) DAYS FROM SHIPMENT DATE.

TROXLER ELECTRONIC LABORATORIES, INC.

Troxler International, Ltd.
Troxler Electronics (Canada), Ltd.
3008 Cornwallis Road
Post Office Box 12057
Research Triangle Park, NC 27709 USA

NOTICE TO CONSUMERS

Any disclaimer or limitation on the remedies expressed above shall not be effective to the extent prohibited by state or federal law.

NOTE: THIS WARRANTY EXCLUDES DAMAGE INCURRED IN SHIPMENT. IF THIS INSTRUMENT IS RECEIVED IN DAMAGED CONDITION, THE CARRIER SHOULD BE CONTACTED IMMEDIATELY. ALL CLAIMS FOR DAMAGE IN TRANSIT SHOULD BE FILED WITH THE CARRIER. IF REQUESTED, TROXLER WILL AID IN FILING OF CLAIMS AND/OR LOCATING GAUGES LOST IN TRANSIT.