

# Device/PLC Connection Manuals

---



## About the Device/PLC Connection Manuals





Prior to reading these manuals and setting up your device, be sure to read the "Important: Prior to reading the Device/PLC Connection manual" information. Also, be sure to download the "Preface for Trademark Rights, List of Units Supported, How to Read Manuals and Documentation Conventions" PDF file. Furthermore, be sure to keep all manual-related data in a safe, easy-to-find location.

## 7.2 Mitsubishi Electric

### 7.2.1 System Structure

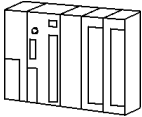
This section explains the system structure for the Ethernet connection between a PLC made by Mitsubishi Electric and the GP.

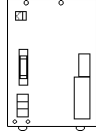
#### ■ MELSEC-A Series/AJ71E71, A1SJ71E71 (using Ethernet Unit)

CPU	Link I/F	Cable Diagram	Cables	Unit	GP/GLC
	 Ethernet Unit				
A2A, A3A, A2N, A2U-S1	AJ71E71		Ethernet cable (conforming to the IEEE802.3)	Digital's GP Ethernet I/F Unit (GP070-ET11/GP070- ET41)	GP/GLC Series <sup>*1</sup>
A2US	A1SJ71E71			GP77R Series Multi Unit E (GP077-MLTE11) GP-377R Series Multi Unit (GP377-MLTE11)	



\*1 When using GP/GLC and extended units, refer to

**Reference** Mitsubishi Electric Connectable Devices.

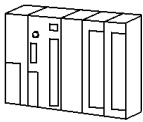

- For cable connections, refer to the user's manual for each optional unit. For the GP2000 and GLC2000 series, however, refer to the user's manual for the main unit.

■ MELSEC-Q Series

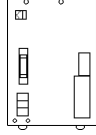
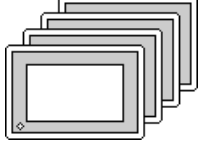
CPU	LinkI/F	Cable Diagram	Cables	Unit	GP/GLC
	 Ethernet Unit				
Q02CPU Q02HCPU Q06HCPU Q12HCPU Q25HCPU	QJ71E71 QJ71E71-B2		Ethernet cable (conforming to the IEEE802.3)	Digital's GP Ethernet I/F Unit GP070-ET11 GP070-ET41 GP377-MLTE11 GP377-MLTE41 GP077-MLTE41	GP/GLC Series <sup>*1</sup>

\*1 When using GP/GLC and extended units, refer to

**Reference** Mitsubishi Electric Connectable Devices.



- For cable connections, refer to the user's manual for each optional unit. For the GP2000 and GLC2000 series, however, refer to the user's manual for the main unit.

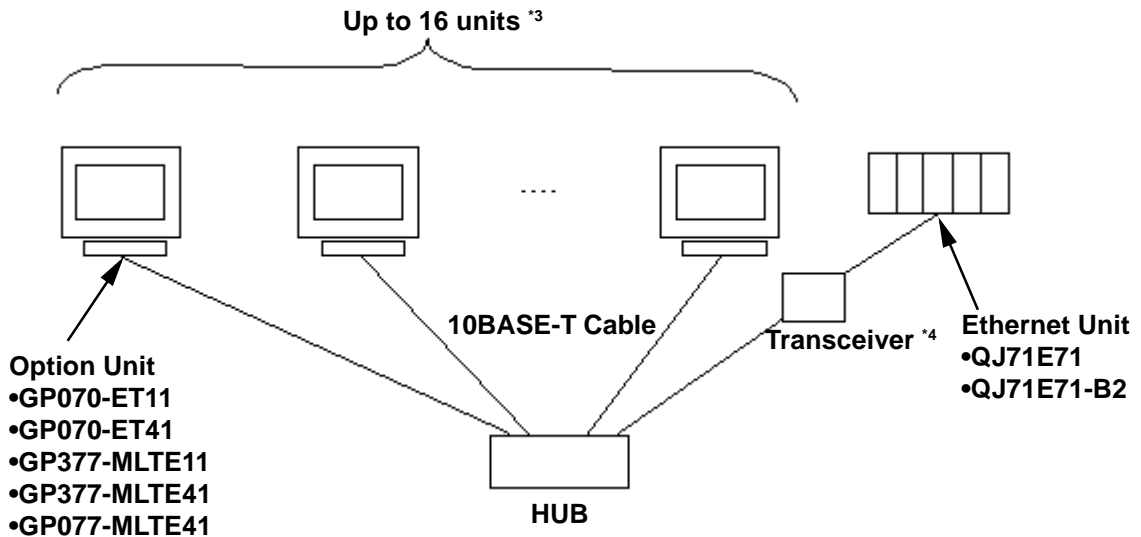

◆ Connection Structure



\*3 When transmitting data via the PLC's OPEN Setting feature instead of the Auto OPEN UDP Port feature, up to 16 GP units can be connected. Also, when using the PLC's Auto Open UDP Port feature, there is no limitation for the number of GP units that can be connected.

\*4 When using a 10BASE-5 or a 10BASE-2 cable with the Mitsubishi PLC, use a transceiver to connect this cable with the 10BASE-T cable.

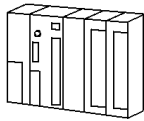
■ MELSEC-QnA Series

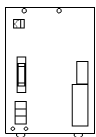
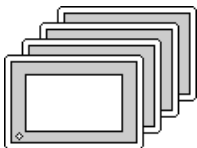
CPU	Link I/F	Cable Diagram	Cables	Unit	GP/GLC
	 Ethernet Unit				
Q2A Q2A-S1 Q3A Q4A Q4AR	AJ71QE71 AJ71QE71-B5		Ethernet cable (conforming to the IEEE802.3)	Digital's GP Ethernet I/F Unit GP070-ET11 GP070-ET41 GP377-MLTE11 GP377-MLTE41 GP077-MLTE41	GP/GLC Series <sup>*1</sup>
Q2AS Q2AS-S1 Q2ASH Q2ASH-S1	A1SJ71QE71-B2 A1SJ71QE71-B5				

\*1 When using GP/GLC and extended units, refer to

**Reference** Mitsubishi Electric Connectable Devices.



- For cable connections, refer to the user's manual for each optional unit. For the GP2000 and GLC2000 series, however, refer to the user's manual for the main unit.

◆ Connection Structure

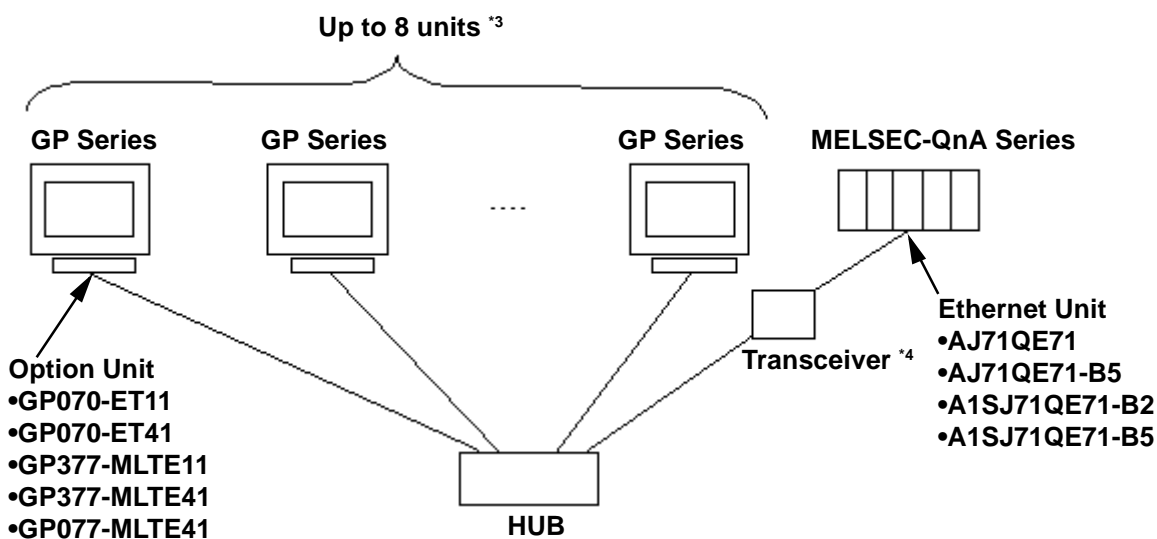

\*3 When transmitting data via the PLC's OPEN Setting feature instead of the Auto OPEN UDP Port feature, up to 8 GP units can be connected. Also, when using the PLC's Auto Open UDP Port feature, there is no limitation for the number of GP units that can be connected.







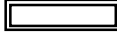

\*4 When using a 10BASE-5 or a 10BASE-2 cable with the Mitsubishi PLC, use a transceiver to connect this cable with the 10BASE-T cable.

**7.2.2 Supported Devices**

The following describes the range of devices supported by the GP.

**MELSEC-A Series**

 Setup System Area here.

Device	Bit Address	Word Address	Particulars
Input Relay	X0000 - X1FFF	X0000 - X07F0	
Output Relay	Y0000 - Y1FFF	Y0000 - Y07F0	
Internal Relay	M0000 - M8191	M0000 - M8176	
Latch Relay	L0000 - L8191	---	
Special Relay	M9000 - M9255	M9000 - M9240	
Annunciator	F0000 - F2047	F0000 - F2032	
Link Relay	B0000 - B0FFF	---	
Timer (contact)	TS0000 - TS2047	---	
Timer (coil)	TC0000 - TC2047	---	
Counter (contact)	CS0000 - CS1023	---	
Counter (coil)	CC0000 - CC1023	---	
Timer (current value)	---	TN0000 - TN2047	
Counter (current value)	---	CN0000 - CN1023	
Data Register	---	D0000 - D6143	
Special Register	---	D9000 - D9255	
Link Register	---	W0000 - W0FFF	
File Register	---	R0000 - R8191	

L/H



**Note:** The range of supported devices may differ depending on your CPU. For the range of supported devices for each CPU, refer to the User's Manual for Model AJ71E71 Interface Unit by Mitsubishi Electric.

■ MELSEC-Q/MELSEC-QnA Series

     Setup System Area here.

Device	Bit Address	Word Address	Particulars
Input Relay	X0000 - X1FFF	X0000 - X1FF0	
Output Relay	Y0000 - Y1FFF	Y0000 - Y1FF0	
Internal Relay	M0000 - M32767	M0000 - M32752	
Special Relay	SM0000 - SM2047	SM0000 - SM2032	
Latch Relay	L0000 - L32767	L0000 - L32752	
Annunciator	F0000 - F32767	F0000 - F32767	
Edge Relay	V0000 - V32767	V0000 - V32752	
Step Relay	S0000 - S8191	S0000 - S8176	
Link Relay	B0000 - B7FFF	B0000 - B7FF0	
Special Link Relay	SB000 - SB7FF	SB000 - SB7F0	
Timer (contact)	TS00000 - TS23087	_____	
Timer (Coil)	TC00000 - TC23087	_____	
Aggregate Timer (contact)	SS00000 - SS23087	_____	
Aggregate Timer (coil)	SC00000 - SC23087	_____	
Counter (contact)	CS00000 - CS23087	_____	
Counter (coil)	CC00000 - CC23087	_____	
Timer (current value)	_____	TN00000 - TN23087	
Aggregate Timer (current value)	_____	SN00000 - SN23087	
Counter (current value)	_____	CN00000 - CN23087	
Data Register	_____	D00000 - D25983	
Special Register	_____	SD0000 - SD2047	
Link Register	_____	W0000 - W657F	
Special Link Register	_____	SW000 - SW7FF	
File Register (Normal)	_____	R0000 - R32767	
File Register (Serial)	_____	0R0000 - 0R7FFF	
	_____	1R0000 - 1R7FFF	
	:	:	:
	_____	30R0000 - 30R7FFF	
	_____	31R0000 - 31R67FF	

L/H



- **The device ranges given here show the maximum range available for each parameter setting.**
- **When using File Registers, depending on the type of unit used, a PLC Memory Card may be required. Depending on the size of the Memory Card, the device ranges will change. For details, refer to Mitsubishi Electric Co., Ltd's User's Manual.**
- **When using the QnA series unit's File Registers, depending on the QnA unit's CPU version, certain usage restrictions will apply. For details, refer to Mitsubishi Electric Co., Ltd.'s User's Manual for QnA Series.**

**7.2.3 Environment Setup**

**■ GP Settings**

The communications settings for the GP, which are required for communications via the Ethernet, as shown below:

**◆ SET UP OPERATION SURROUNDINGS Menu**

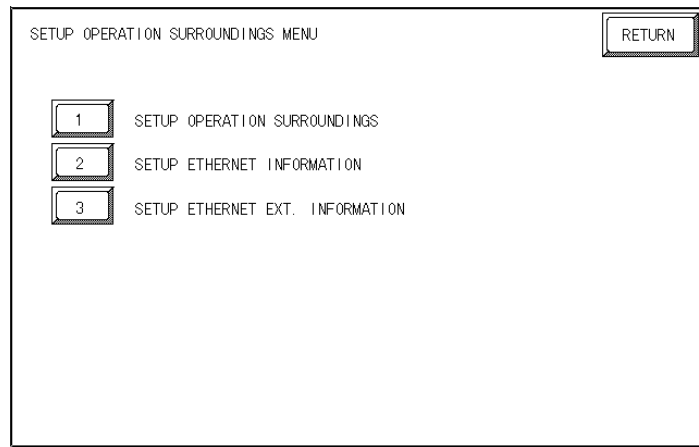

**◆ SET UP ETHERNET INFORMATION**

Select “SET UP ETHERNET INFORMATION,” and then enter the necessary information for each item.

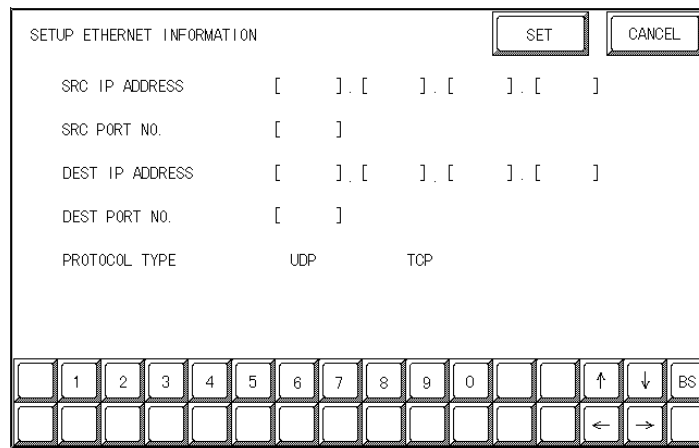

**• SRC IP ADDRESS**

Enter the IP address for the GP at your station. To do this, separate the 32 bits of the IP address into four segments of eight bits each, delimit those segments with a dot, and then enter them as decimal numbers.

**• SRC PORT NO.**

Enter your station port number in the range from 1024 to 65535.

**• DEST IP ADDRESS**

Enter the IP address of the other station (the MELSEC).



- **DEST PORT NO.**

Enter the port number of the other station in the range from 1024 to 65535.

- **PROTOCOL TYPE**

You can select either UDP or TCP communication. If the power will be turned ON/OFF synchronously, it is recommended that you use UDP communications.



For the IP addresses, check with the network manager. Do not specify any duplicate IP address.



**When using the built-in Ethernet port on a GP2000 or GLC2000 series unit, be sure not to set any duplicate "SRC PORT No." values.**

**Check the 2-way driver's "SRC PORT No." setting via the following menu:**

**GP OFFLINE mode's Main menu [INITIALIZE] -> [SETUP OPERATION SURROUNDINGS] -> [EXTENDED SETTINGS] -> [SETUP ETHERNET INFORMATION].**

**The default value is 8000. The 2-way driver uses this port and the following 9 ports (8000 ~ 8009). Be sure not to use Port No.s 5001 and 5002, since they are used by the PLC's Ethernet Unit.**

◆ **SET UP NETWORK EXT. INFORMATION**

SETUP NETWORK EXT. INFORMATION											SET		CANCEL		
SEND WAIT TIME		[ ] (ms)													
TIMEOUT		[ ] (x 2sec)													
IP ROUTER ADDRESS		[ ]	[ ]	[ ]	[ ]	[ ]	[ ]	[ ]	[ ]	[ ]	[ ]				
SUBNET MASK		[ ]	[ ]	[ ]	[ ]	[ ]	[ ]	[ ]	[ ]	[ ]	[ ]				
UDP RETRY COUNT(0-255)		[ ]													
[ ]	[ 1 ]	[ 2 ]	[ 3 ]	[ 4 ]	[ 5 ]	[ 6 ]	[ 7 ]	[ 8 ]	[ 9 ]	[ 0 ]	[ ]	[ ]	[ ↑ ]	[ ↓ ]	[ BS ]
[ ]	[ ]	[ ]	[ ]	[ ]	[ ]	[ ]	[ ]	[ ]	[ ]	[ ]	[ ]	[ ]	[ ← ]	[ → ]	[ ]

- **SEND WAIT TIME (0 to 255)**

Wait time can be added when a command is transmitted from the GP. Use the wait time if the traffic on the communications line is heavy. If no wait time is required, enter "0."

- **TIMEOUT (0 to 65535)**

Enter the desired timeout value. If no response is received from the other station within the specified time, a timeout occurs. If “0” is specified, the default time is 15 seconds when it is TCP communication, and is 5 seconds when it is UDP communication.

- **IP ROUTE ADDRESS**

Enter the IP address of the router (only one). If no router is used, enter “0” in all fields.

- **SUBNET MASK**

Enter subnet masks. If no subnet mask is used, enter “0” in all fields.

- **UDP RETRY COUNT (0 to 255)**

Designates the number of times the GP re-sends a command when there is no reply from the other port and a timeout occurs. When no reply is received after the re-try setting number is reached, an error message will appear on the GP screen.



*If the memory is initialized in the OFFLINE mode, random values may be included. Be sure to check the displayed values.*

◆ **SET UP OPERATION SURROUNDINGS**

SET UP OPERATION SURROUNDINGS												SET	CANCEL		
STARTING ADDRESS OF SYSTEM DATA AREA												[	]		
SYSTEM AREA    READING AREA SIZE (0-256)												[	]		
DATA CODE												BINARY	ASCII		
RESET GP DATA WRITE ERROR												ON	OFF		
	1	2	3	4	5	6	7	8	9	0			↑	↓	BS
	1D	2D	3D	4D	1B	2B	3B	4B					←	→	

- **DATA CODE (Set only when connecting to a MELSEC-Q Series and MELSEC-QnA Series)**

This selection controls the type of DATA CODE settings used. Select either BINARY or ASCII, and confirm that the PLC settings are the same.

## ■ Sample Ladder Program

### ◆ MELSEC-A Series (Ethernet interface unit: AJ71E71)

PLC's Ladder Program is needed to communicate with the GP.

**Reference** *For the complete details of settings, refer to the user's manual for Model AJ71E71 Ethernet Interface Unit (Mitsubishi Electric).*

The following is a sample ladder.

#### <Sample Ladder>

```
LD      M9038
DMOV P Hxxxxxxx      D100 (IP address of PLC) *1
MOV P  K0      D102
MOV    H0100   D116 (Settings for UDP communications)
MOV    K1024   D124 (Port number of PLC)
MOV    K1024   D127 (Port number of GP)
DMOV   Hxxxxxxx D125 (IP address of GP) *1
DMOV   HFFFFFFF D128
MOV    HFFFF   D130
LD      M9036
TOP    H0000 H0000 D100 K50
LD      X0019
MOV    K5      D113
TOP    H0000 K13 D113 K1
LD      M9036
OUT    Y0019
LD      M9036
OUT    Y0008
END
```

\*1 For the IP addresses, check with the network manager. "xxxxxxx" stands for an IP address in the hexadecimal notation. Do not specify any duplicate addresses.



**Important**

**Be sure that any addresses (D...) used in the communications settings for the PLC are not the same as the first address of the system on the GP.**

◆ MELSEC-Q Series

Prior to GP starting GP communication, the MNET/10H Ethernet settings must be set in the PLC's ladder logic software. The setting values are as shown below.

1. Network Parameter MNET/10H Ethernet Settings
2. Ethernet Operation Settings
3. OPEN Settings

1. Network Parameter MNET/10H Ethernet Settings

Items	PLC Settings
Network Classification	Ethernet
First I/O No.	Any number <sup>*1</sup>
Network No.	Any number <sup>*1</sup>
Group No.	Any number <sup>*1</sup>
Machine No.	Any number <sup>*1</sup>
Mode	Online

*\*1 This setting does not effect PLC/GP communication.*

2. Ethernet Operation Settings

Recommended Settings

Items	PLC Settings	
Data Code Settings	BINARY Code	ASCII Code
Initial Timing Settings	Not waiting for OPEN	Always waiting for OPEN
IP Address Settings	Any number <sup>*1</sup>	
Write Possible in RUN mode	Not allowed	Allowed <sup>*2</sup>

*\*1 Please contact your computer network supervisor to confirm your setting data.*

*\*2 When performing Write from a GP in RUN mode, set the Write Possible in RUN mode to "Allowed".*

3. OPEN Settings

Items	PLC Settings			Remarks
Protocol	TCP/IP		UDP/IP	Should be same as GP unit's Communication Format Settings.
OPEN Format <sup>*1</sup>	Active	Fullpassive	Unpassive	Either Fullpassive or Unpassive can be used.
SRC Port No.	Any number <sup>*2</sup>			Should be same as GP unit's DEST Port No.
DEST IP Address	Any number <sup>*2*3</sup>			Should be same as GP unit's SRC IP Address.
DEST Port Address	Any number <sup>*2*3</sup>			Should be same as GP unit's SRC Port No
Fixed Buffer	Transmission	Subscription		Independent of GP.
Fixed Buffer Method	Yes	No		Independent of GP.
Paring Open	Yes	No		Independent of GP.
Confirming	No	Yes		Both can be used.

- \*1 Can be used only when Protocol is set to TCP/IP.
- \*2 Please contact your computer network supervisor to confirm your setting data.
- \*3 If OPEN Format is set to "Unpassive", this item does not need to be set

When the Auto Open UDP Port feature is used, the Table 3. OPEN Settings are not needed. When these settings are used, however, the PLC's port number is 5000 (default setting).

**Reference** For details, refer to Mitsubishi Electric's Q and QnA Series Ethernet Interface User Manuals.

◆ MELSEC-QnA Series

PLC's Ethernet Unit Dipswitch Settings and a Ladder Program are needed to communicate with the GP.

Ethernet Unit Settings

- Operation Mode Setting Switch

Contents	Settings
Operation Mode Settings	0:Online

• Communication Condition Setting Switch

  Recommended Settings

Switch	Contents	Settings	
SW1	Action performed when TCP/IP Timeout occurs	OFF:When TCP/IP Timeout Error occurs, the line is closed.	ON:When TCP/IP Timeout Error occurs, the line is not closed.
SW2	Data Code Settings	OFF:BINARY Code	ON:ASCII Code
SW3	Auto Start Settings	OFF:Perform action(s) defined in Y19.	ON:Regardless of Y19, after unit is turned ON again or is Reset, Initialization is performed.
SW4-SW6	Cannot use (fixed to OFF)		
SW7	CPU Communication Timing Settings <sup>*1</sup>	OFF:Write in RUN mode is Impossible.	ON:Write in RUN mode is Possible.
SW8	Initial Timing Settings	OFF:Quick Start (start without time delay)	ON:Normal Start (Start after 20 seconds time delay)

*\*1 When performing Write From GP in RUN mode, set the CPU Communication Timing Settings to ON.*

Sample Ladder Program

This Sample Ladder Program is for communication via the Auto Open UDP Port No. (default:5000).

- PLC IP Address: 192.168.0.1
- PLC Port No.: 5000

When communicating via this function, the GP's IP Address and Port No. do not need to be set.

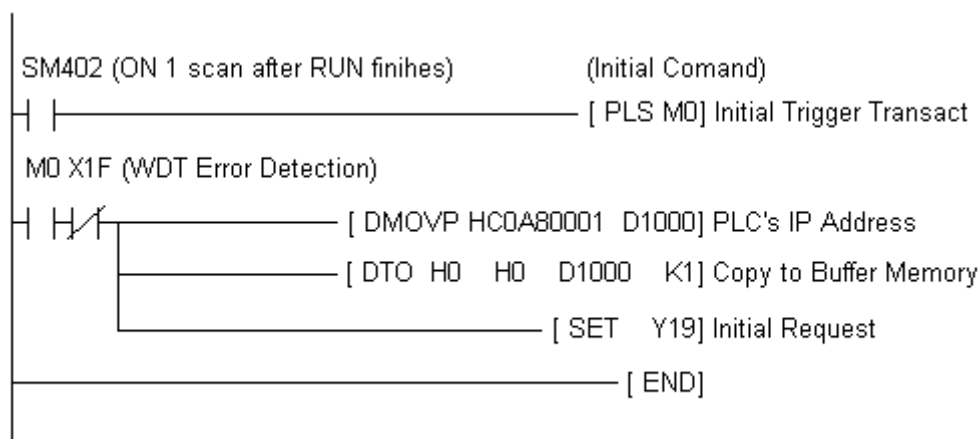

**Reference**

*The sample ladder above is the minimum ladder to communicate with GP via UDP/IP. For details about error processing and TCP/IP communication, refer to Mitsubishi Electric Co., Ltd.'s User's manual for QnA Series Ethernet Interface Unit (Detail manual).*

## 7.2.4 Error Code

**Reference** *About the GP Ethernet Specific Error Codes, refer to the end of this Chapter, "Protocol Stack Error Codes".*

### ■ PLC SPECIFIC ERROR CODES

PLC error codes are displayed by the “Host Communication Error (02:\*\*:\*\*)”, and indicated in the left lower corner of the GP screen. (\*\*:\*\* indicates the PLC’s specific error codes)

Error Code	Description	Status
0055	Write error in RUN mode	Write in RUN mode is set to OFF.
4031	CPU Device Settings Error	Designated device is outside allowable range.

**Reference** *For more details about error codes, refer to Mitsubishi Electric Co., Ltd.’s User’s Manuals for Q Series Ethernet Interface Unit and QnA Series Ethernet Interface Unit.*