

Lithium



Li- 3312 Manual

 **electrovaya**

Notice

The information in this user's manual is subject to change without notice.

THE MANUFACTURER OR RESELLER SHALL NOT BE LIABLE FOR ERRORS OR OMISSIONS CONTAINED IN THIS MANUAL AND SHALL NOT BE LIABLE FOR ANY CONSEQUENTIAL DAMAGES, WHICH MAY RESULT FROM THE PERFORMANCE OR USE OF THIS MANUAL.

The information in this user's manual is protected by copyright laws. No part of this manual may be photocopied or reproduced in any form without prior written authorization from the copyright owners.

Copyright June, 2004
All rights reserved.

Microsoft and Windows are registered trademarks of Microsoft Corporation. DOS, Windows 95/98/ME/2000/NT/XP are trademarks of Microsoft Corporation.

Product names mentioned herein may be trademarks and/or registered trademarks of their respective owners/companies.

The software described in this manual is delivered under a license agreement. The software may be used or copied only in accordance with the terms of the agreement.

This product incorporates copyright protection technology that is protected by method claims of certain U.S. patents and other intellectual property rights owned by Macrovision Corporation and other rights owners. Use of this copyright protection technology must be authorized by Macrovision Corporation, and is intended for home and other limited viewing uses only unless otherwise authorized by Macrovision Corporation. Reverse engineering or disassembly is prohibited.

Rev 1.0

TABLE OF CONTENTS

PREFACE

Symbols and Conventions

Protecting Your Computer - Avoid Abusive Handling and Adverse Environment

Chapter Summaries

1. GETTING TO KNOW THE BASICS

Performance Features (1-2,3)

System at a Glance (1-4)

Front View (1-4,5,6,7)

Rear View (1-8,9,10)

Bottom View (1-11,12,13)

AC Adapter (1-14)

LED Status Indicators (1-15,16)

Keyboard Features (1-17)

Function (Quick) Keys (1-17)

Windows Keys (1-18)

Embedded Numeric Keypad (1-18)

Touch Pad (1-19)

Graphic Subsystem (1-20)

Adjusting the Display Brightness (1-20)

Extending the Life of the TFT Display Panel (1-20)

Opening and Closing the Display Panel (1-21)

Audio Subsystem (1-22)

Adjusting the Volume in Windows (1-22)

Voice Recording (1-22)

Modem and Modem Setting (1-23)

Ethernet Adapter (1-24)

2. BIOS SETUP AND SECURITY

Entering the BIOS Setup Screen (2-3)

Leaving the BIOS Setup Screen (2-3)

BIOS Action Keys (2-3)

Modifying the BIOS Settings (2-4)

- Main Setup (2-4)
- Advance Setup (2-4)
- Security Setup (2-5,6)
- Power Setup (2-6,7)
- Boot Setup (2-7,8)
- Exit Setup (2-8)

3. BATTERY POWER & POWER MANAGEMENT

- The Battery Pack (3-2)
 - Lithium-Ion Battery Technology (3-2)
 - Battery Low-Power Warning (3-3)
- Installing and Removing the Battery Pack (3-4,5)
- Charging the Battery and Charging Time (3-5)
- Checking the Battery Level (3-6)
- Prolonging the Battery's Life and Usage Cycles (3-6)
- Using Windows Power Options (3-7)
 - Windows' Power Schemes (3-7,8)
 - Suspend Modes (3-9,10)
 - Power Button Action (3-11)
 - Low Battery Warning (3-12)
 - Power Manual Quick Access (3-13)

4. UPGRADING YOUR COMPUTER

- Upgrading the Hard Disk Drive (4-2,3,4,5)
- Upgrading the System Memory (4-6,7,8,9)
- Installing a Mini PCI Card to the System (4-10,11,12)

5. TROUBLE-SHOOTING

- First Step (5-2,3)
- Audio Problems (5-4)
- Hard Disk Problems (5-5,6)
- CD-ROM, DVD-ROM, CD-RW, or Combo Drive Problems (5-7)
- Display Problems (5-8)
- Keyboard and Mouse Problems (5-9)
- CMOS Battery Problems (5-10)
- Memory Problems (5-11)
- Modem Problems (5-12)

Network Adapter / Ethernet Problems (5-13)

PC Card / PCMCIA Problems (5-14)

Performance Problems (5-15)

Firewire (IEEE1394) and USB2.0 Problems (5-16)

APPENDIX A Product Specification

APPENDIX B Agency Regulatory Notices

APPENDIX C Power Cinema Installation and User Manual

APPENDIX B Bluetooth Module Installation and User Manual

Preface

Using This Manual

This User's Manual contains general information about the hardware and software setup, troubleshooting, and technical specifications of the notebook computer.

Symbols and Conventions

The following conventions and symbols are used in this manual:

- When keys are to be pressed at the same time, a plus (+) symbol is used. For instance, Fn+F7 means holding Fn and F7 keys at the same time.
- When a series of clicking actions is needed in Windows O/S, [] and > symbols are used. For instance, [Start > Settings > Control Panel > Display] means clicking the Start icon first, then the Settings, then the Control Panel, then the Display icon.
- When you need to make a selection with the touch pad (or mouse), you will be asked to 'select' or 'click' or 'double-click', 'right-click' the item.



Note: Text in this format and symbol means specific instructions, commentary, sidelights, or any additional information or notes that you should be aware of.



Warning: Text in this format and symbol means that failures to comply with the given instructions or information could result in damage to your computer or could cause bodily harm or loss of life.

Protecting Your Computer - Avoid Abusive Handling and Adverse Environment

Follow the advice below will help ensure that you get the most out of your Investment.

Your computer will serve you well if you take good care of it.

- Do not expose the computer to direct sunlight or place it near sources of heat.
- Do not subject it to temperatures below 0°C (32°F) or above 30°C (86°F).
- Do not expose the computer to magnetic fields.
- Do not expose the computer to moisture or rain.
- Do not spill water or liquid on the computer.
- Do not subject the computer to adverse shock and vibration.
- Do not expose the computer to dust and dirt.
- Do not place objects on top of the computer to avoid damaging the computer.
- Do not place the computer on rocky surfaces.

Here are some ways of taking care of your AC adapter.

- Do not connect the adapter to any devices other than your computer.
- Do not let water get into the adapter.
- Do not block the ventilation airway of the adapter.
- Keep the adapter in a cool and ventilated place.
- Do not step on the power cord or place heavy objects on top of it.
- Carefully tuck away the power cord and any cables away from pedestrian traffic.
- When unplugging the power cord, do not pull on the cord itself but pull on the plug.

- Keep the adapter away from children.
- The total ampere ratings of the equipment plugged in should not exceed the ampere rating of the cord if you are using an extension cord.
- The total current rating of all equipment plugged into a single wall outlet should not exceed the fuse rating.
- Do not connect other AC adapter to your notebook. This Notebook uses exclusively the AC adapter LITE-ON PA-1650-08 (65W); Lishin 0202A2065 (65W); Hipro HP-OK065E13 (65W)

When cleaning the computer, observe these steps:

1. Power off the computer and remove the battery pack.
2. Disconnect the AC adapter.
3. Use a soft cloth dampened with water. Do not use liquid or aerosol cleaners.

Contact your dealer or see your service technician if any of the following occurs:

- Computer has been dropped or the body has been damaged.
- Liquid has been spilled into the product.
- The computer does not operate normally.

Cleaning the Ventilation Grills:

It is suggested that you clean the ventilation grills regularly to maintain optimal thermal regulation of the notebook. To do this, you may use a soft brush or a vacuum cleaner (with appropriate head adapter) to remove the dust buildup on the ventilation grills.

Chapter Summaries

The following is a summary of the available chapters and appendices in this manual.

Chapter 1: Getting to Know the Basics

In this chapter, you will learn the basic operations and features of your computer. It gives you a general understanding of the components of your computer.

Chapter 2: BIOS Setup / Security

In this chapter, you will learn how to change various firmware settings and what the settings mean. Also, you will learn how to take advantage of the built-in security feature provided by the BIOS.

Chapter 3: Battery Power & Power Management

In this chapter, you will learn the fundamentals of power management and how to use them to achieve longer battery life.

Chapter 4: Upgrading Your Computer

In this chapter, you will learn how to upgrade the system memory, the hard disk drive, and to install wireless mini PCI card.

Chapter 5: Trouble-Shooting

In this chapter, you will learn how to solve common hardware and software problems.

Appendix A: Product Specification

In this section, you will find a list of the computer's system specifications.

Appendix B: Agency Regulatory Notices

In this section, you will find the general electro-magnetic and safety regulatory information.

Appendix C: Power Cinema Installation and User Manual

In this section, you will learn how to install Power Cinema and learn to use its features.

Appendix D: Bluetooth Module Driver Installation and User Manual

In this section, you will learn how to use the Bluetooth Module.

C H A P T E R ▼ O N E

GETTING TO KNOW THE BASICS

This chapter introduces the features and components of the computer.

Performance Features

■ High Performance Processor

The notebook PC is equipped with a powerful Mobile Intel Pentium M processor of the latest sub-micron process, processor technologies, and high bus bandwidths.

■ Advanced Graphic Engine

An Intel Integrated Extreme Graphic 2 video processor gives excellent graphic performance. The advanced graphic chip also incorporates a hardware-based motion-compensation engine, which gives you smooth MPEG video playback. 3D graphics capability also adds realism to PC games.

■ LCD Display

The computer is equipped either with a 12.1-inch TFT in standard format (4:3 aspect ratio) or 12.1-inch TFT in *Wide* format (16:10 aspect ratio) high-resolution display panel for clear text and brilliant colors.

■ Expandability

The system offers upgradeable hard disk drive and 2 DDR SDRAM sockets for expansion, allowing the user to easily increase the storage and system capacities as the need arises.

■ Built-in Multiple Card Reader

There is built-in 4-in-1 card reader to access many of the portable media formats (SD Card, MS Card, MMC Card, and MS-Pro Card). *(Note: In some models, Card Reader may not be available.)*

■ Ethernet Port

The system provides built-in Ethernet network adapter for high bandwidth network connection.

■ **Firewire (IEEE1394 / 1394a) and USB2.0 ports**

In addition to a full array of built-in I/O ports, the computer offers IEEE1394 for ultra high-speed connection to high bandwidth digital video devices and USB2.0 ports to connect to any USB-based peripheral devices. *(Note: In some models, IEEE1394 Port may not be available.)*

■ **Wireless LAN (Optional)**

The optional internal Wireless LAN module allows your notebook to connect wirelessly to other 802.11-enabled systems, devices, or network.

■ **Integrated USB Devices (Optional)**

The optional USB Bluetooth module or USB Thumb Drive gives you added function to the notebook.

System At A Glance

Front View

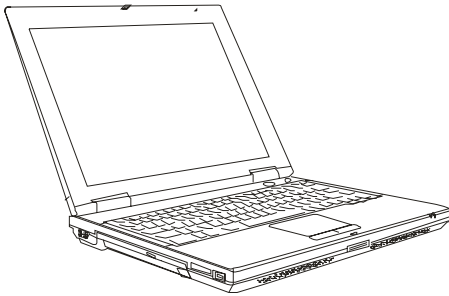
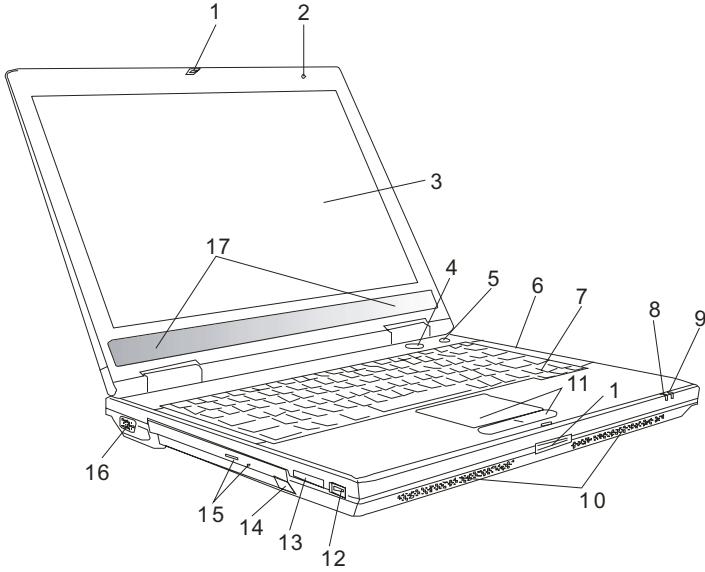



Note: Your computer may come with the 12.1" display in the wide 16:10 aspect ratio or in the standard 4:3 aspect ratio. If your computer comes with the wide 12.1" display, there is an extra pair of built-in loudspeakers located below the display panel.

1. LCD Latch

The LCD latches lock / unlock the LCD panel.

2. Built-in Microphone

The built-in microphone records sound.

3. LCD Display

The panel is where the system content is displayed.

4. Power / Suspend Button

The power/suspend button turns the notebook on and off and it also acts as a system suspend key. Press momentarily to turn on the system. Press and hold for at least 3~4 seconds to turn off the system. How this key behaves can be defined in [Start > Settings > Control Panel > Power Options > Advanced] menu. Press the power / suspend button again to return from the suspend mode. (See Chapter 3 for more details on system suspend function.)

5. Power Cinema Launch Key / Silent Mode Button

This is a dual function key.

Power Cinema Launch (When system is off) –

The key allows you to watch DVD movies in the optical drive without having to boot to Windows. Additionally, Power Cinema application allows you to view photos and play music files in the optical drive as well as in the hard

disk drive. Please see Appendix C to learn how to use Power Cinema.

Silent Mode Button (When system has already booted to Windows) –

Pressing the key enables the system to lower its power usage, therefore turning off the fan to achieve lowest operating noise.



Note: The way the Power Cinema works is that when the key is pressed, the system boots to a Linux-based O/S and movie-player application in a separate hard drive partition. In case you have a brand new HDD or when you need to re-install O/S and Power Cinema, please go to Appendix C for installation instructions.

6. LED Status Indicator

The LED Status indicators reveal the status of these functions: Numeric keypad, cap lock, scroll lock, WLAN module enabling and disabling and also the ODD, HDD activities. (See the LED Status Indicator Section for details.)

7. Keyboard

The keyboard is used to enter data. It has an embedded numeric keypad and cursor control keys. (See Keyboard Section for details.)

8. Suspend Status LED

Flashing green light indicates the notebook is in suspend mode. (See the LED Status Indicator Section for details.)

9. Battery Status LED

The multi-color LED indicates the battery status of the notebook. (See the LED Status Indicator Section for details.)

10. Built-in Stereo Speakers

The built-in speakers output the sound in stereo.

11. Touch Pad

The touch pad is a built-in pointing device with functions similar to a mouse.

12. USB2.0 Port

The Universal Serial Bus (USB2.0-compliant) port allows you to connect a wide variety of devices to your computer at a rate of up to 480 Mbps. This port conforms to the latest USB2.0 plug-and-play standards.

13. 4-in-1 Card Reader

The 4-in-1 Card Reader supports SD Card, MS Card, MMC Card, and MS-Pro Card.



Note: In some models, the Card Reader may not be available.

14. USB Device (Optional)

You may install the optional Bluetooth module or USB Thumb Drive into this slot. Please see Appendix D to learn how to use the Bluetooth device.

15. Optical Drive and Disk Eject Button and Manual Eject Key Hole

If your computer comes with the Combo drive, DVD-RW, DVD+RW, or DVD-Dual drive, you may save data onto a CD-R / CD-RW or DVD RW disc. Press the eject button to eject the disk tray. The manual eject keyhole allows you to manually eject a jammed disk.

16. External VGA Port

The 15-pin VGA analog port is for connecting the external CRT monitor or projector.

17. Built-in Stereo Speakers

If your system comes with the 12.1-inch wide aspect ratio panel, there is an additional pair of speakers built-in.

Rear View

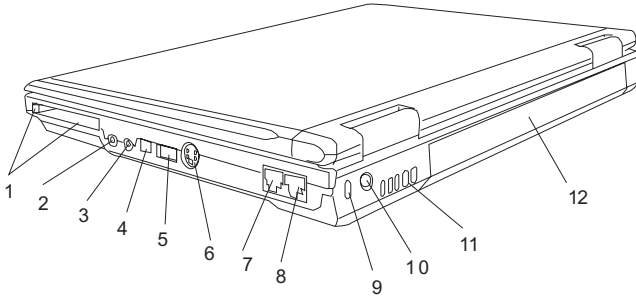

Warning: Do not place any heavy objects on the top of notebook. This may damage the display

1. PC Card Slot (Type II PCMCIA) and Card Eject Button

The slot is where PC Card (Type II PCMCIA) is inserted. Press the eject button to release the PC Card.



Note: In some models, the PC Card Slot may not be available.

2. Stereo Headphone / SPDIF-out Jack

The stereo headphone jack (3.5-mm diameter) is where you connect the headphones or external speakers.

Alternatively, you may connect the SPDIF output to an external DTS, AC3, or PCM sound processor / decoder in your home stereo system.



Note: In some models, the SPDIF-out feature may not be available.

3. Microphone Jack

The microphone jack (3.5-mm diameter) is where you connect a microphone.

4. Firewire / IEEE1394 / 1394a Port

This is a high-speed serial data port. You may connect any Fire-wire-ready device to this port.



Note: In some models, the Firewire/1394 Port may not be available.

5. USB2.0 Port

The Universal Serial Bus (USB2.0-compliant) port allows you to connect a wide variety of devices to your computer at a rate of up to 480 Mbps. This port conforms to the latest USB2.0 plug-and-play standards.

6. TV (S-Video) Port

The S-Video port permits you to redirect the screen output to a television set or any analog video playback device. This TV Port is copyright protected; when DVD movie is played, the output is scrambled to prevent analog recording.

7. Modem Port

This is where you plug the phone jack (RJ-11) for fax/modem functions.

8. Ethernet / LAN Port

The port connects to a network hub via the RJ-45 cable and also conforms to 10/100Base-TX transmission protocol.

9. Kensington Lock Key Hole

A Kensington-type security lock latches to this keyhole for anti-theft purpose.

10. Power Jack (DC-in)

The DC-out jack of the AC Adapter connects here and powers the computer.

11. Ventilation Grill

The fan grill is where air is exchanged to dissipate the internal heat. Do not block this airway completely.

12. Battery Pack

The battery pack is a built-in power source for the notebook.

Bottom View

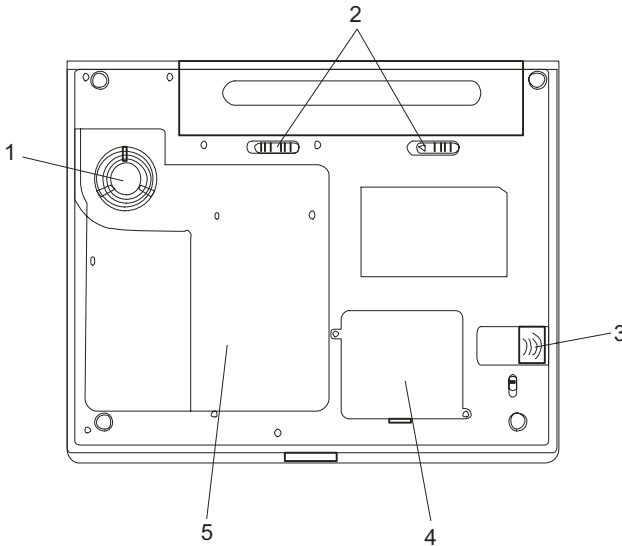

1. Ventilation Grill

The fan grill is where air is exchanged to dissipate the internal heat. Do not block this airway completely.



Warning: Do not block the Fan Grill outlet. Place the machine on hard surface only. The bottom case may get very hot.

2. Battery Pack and Battery Latch

The battery pack is a built-in power source for the notebook. Slide the battery latch to release the battery pack.

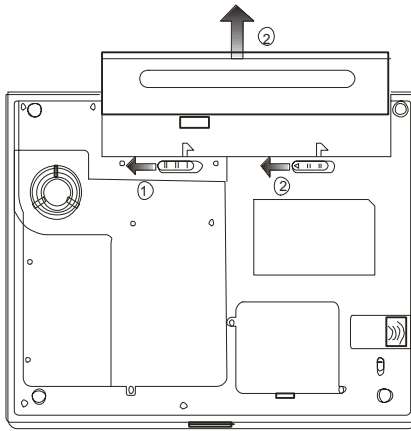

3. USB Device (Optional)

You may install the optional Bluetooth module or USB Thumb Drive into this slot. Please see Appendix D to learn how to use the Bluetooth device. And make sure you put the latch in the locked position. Put the latch in the unlocked position before removing the Bluetooth module.

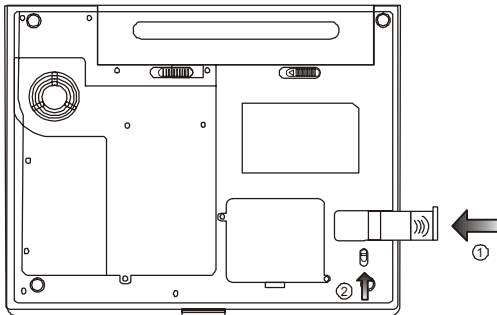

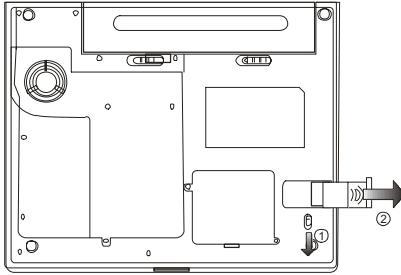

4. **Wireless LAN Module Bay (Optional)**

You may install the optional wireless LAN module into this slot.

5. **System Device Cover**

The system's processor with cooler assembly, hard disk drive, and DDR memory module are located under the case cover.

The system memory and HDD can be upgraded to a larger capacity. (See Chapter 4 for instructions on a memory upgrade.)

AC Adapter

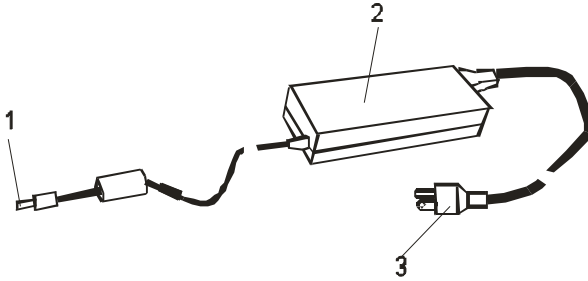

1. DC-out Connector

The DC-out connector docks to the power jack (DC-in) on the computer.

2. Adapter

The adapter converts alternating current into constant DC voltage for the computer.

3. AC Plug

The AC plug plugs to the AC wall outlet.







Warning: Make sure you are using a standard 3-prong AC wall socket with a ground pin. If not, you may feel a slight tingling sensation on any of the computer's metal parts such as the I/O ports. This is caused by leakage current when the AC adapter is not properly grounded (via the ground pin). However, the amount of leakage current is within the safety regulation and is not harmful to human body.



LED Status Indicator

The LED Status Indicator displays the operating status of your notebook. When a certain function is enabled, an LED will light up. The following section describes its indication.

System Status Indicator









LED Graphic Symbol	Indication
	Green light indicates the WLAN module is active.
	Green light indicates the hard drive and/or optical drive is being accessed.
	Green light indicates the numeric keypad is activated.
	Green light indicates the cap-lock is activated.
	Green light indicates the scroll-lock is activated.

Power Indicator

LED Graphic Symbol	Indication
	<p>Persistent blue light indicates Power On. Light-off indicates the notebook is in Power Off mode.</p> <p>Blinking blue light indicates system is either in long battery life mode or high performance mode. (If the notebook is on AC power and this LED is blinking, it means the system is now in high performance mode. If the notebook is on battery power and this LED is blinking, it means the system is now in long battery life mode.) The High Performance Mode and Long Battery Life Mode can be enabled or disabled in the BIOS Setup. See Chapter 2 for details.</p>
<p>“P”</p>	<p>Persistent blue light indicates the system is in the Power Cinema mode under Linux O/S. Or,</p> <p>Persistent blue light indicates in Silent Mode under Windows.</p>
	<p>Blinking green light indicates the notebook is in suspend mode.</p>
	<p>Blinking orange light indicates the battery is being charged.</p> <p>Blinking red light indicates the battery power is low when the system is turn ON.</p> <p>Persistent green light indicates the battery is Full.</p> <p>LED-off (Dark) indicates the system is without battery.</p>

Keyboard Features

Function Keys (Quick Keys)

Graphic Symbol	Action	System Control
	Fn + F1	Enters Suspend Mode.
	Fn + F2	Turns the WLAN module on or off.
	Fn + F3	Turns of the battery warning beep off or on.
	Fn + F4	Changes Display Mode: LCD-only, CRT-only and LCD&CRT.
	Fn + F5	Turns Speaker Volume up.
	Fn + F6	Turns Speaker Volume down.
	Fn + F7	Increases Display Brightness.
	Fn + F8	Decreases Display Brightness.
	Fn+Num Lk	Enables the embedded keypad to work in numeric mode. The keys act like numeric keypads in a calculator. Use this mode when you need to do a lot of numeric data entry. An alternative would be to connect an external numeric keypad.
	Fn + Scr Lk	Press the Scroll Lock key and then press \uparrow or \downarrow to move one line up or down.

For various system controls, press the Fn (Function) key and the Fx key simultaneously.

Windows Keys

Your keyboard also has two Windows keys:



1. Start Key

This key allows you to pull up the Windows Start Menu at the bottom of the taskbar.



2. Application Menu Key

This key brings up the popup menu for the application, similar to a click of the right mouse button.

Embedded Numeric Keypad

Press Num Lock to enable the embedded numeric keypad. The numbers are printed in upper right corner of a key, in a color different from the alphabets. This key pad is complete with arithmetic operators (+, -, *, /).

Press Num Lock to revert to normal character keys.

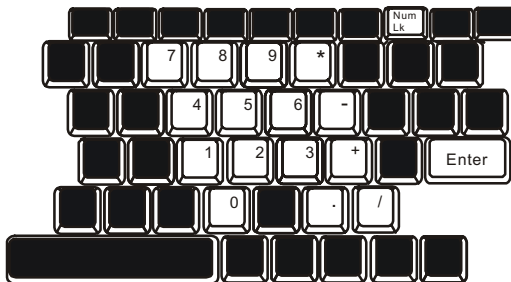

Touch Pad

The built-in touch pad, which is a PS/2-compatible pointing device, senses movement on its surface. As you move your fingertip on the surface of the pad, the cursor responds accordingly.

The following items teach you how to use the touch pad:

1. Move your finger across the touch pad to move the cursor.
2. Press buttons to select or execute functions. These two buttons are similar to the left and right buttons on a mouse. Tapping on the touch pad twice produces is similar to clicking the left button of a mouse.

Function	Left Button	Right Button	Equivalent Tapping Action
Execution	Click twice quickly		Tap twice (at the same speed as double-clicking the mouse button)
Selection	Click once		Tap once
Drag	Click and hold to drag the cursor		Tap twice quickly and on the second tap hold finger to the touch pad to drag the cursor
Access Context Menu		Click once	
Move One Page Up or Down			

Tips on Using the Touch Pad:

1. The double-click speed is timed. If you double-click too slowly, your notebook responds as if you single-clicked twice.
2. Keep your fingers dry and clean when using the touch pad. Also keep the surface of touch pad clean and dry to prolong its life.
3. The touch pad is sensitive to finger movements. Hence, the lighter the touch, the better the response. Heavy touch does not produce better response.

Graphic Subsystem

Your computer uses a high performance 12.1-inch (in either normal 3:4 aspect ratio or wide 16:10 aspect ratio) active matrix TFT panel with high resolution and multi-million colors for comfortable viewing. The Intel Extreme Graphic 2 video graphics accelerator, which is Microsoft DirectX 9 compatible, performs graphic rendering at a lighting-fast speed.

Adjusting the Display Brightness

The notebook uses special key combinations, called hot keys, to control brightness.

Press Fn+F7 to increase the brightness.

Press Fn+F8 to decrease the brightness.



Note: To maximize your battery operating time, set the brightness to the lowest comfortable setting, so that the internal backlight uses less power.

Extending the Life of the TFT Display Device

Observe the following guidelines to maximize the life of the backlight in the display.

1. Set the brightness to the lowest comfortable setting (Fn+F8).
2. When working at your desk, connect your notebook to an external monitor and disable the internal display Fn+ F4.
3. Do not disable the suspend time-outs.
4. If you are using AC power and have no external monitor attached, change to suspend mode when not in use.

Opening and Closing the Display Panel

To open the display, push the LCD latch inwardly and lift up the lid. Then tilt it to a comfortable viewing position.

To close the display cover, fold it down gently until the LCD latches click into place.



Warning: To avoid damaging the display, do not slam it when closing. Do not place any object on top of the computer when the display is closed

Audio Subsystem

Your computer's audio subsystem is Sound Blaster Pro-compatible.

Adjusting the Volume Manually

To increase the volume, press Fn+ F5.

To decrease the volume, press Fn+F6.

Adjusting the Audio Volume in Windows

1. Click the speaker symbol in the task tray in Windows.
2. Drag the volume control bar up or down to adjust the volume.
3. To temporarily silence the speaker without changing the volume setting, click Mute.

Voice Recording

A built-in microphone allows you to record sound. You will need to use audio processing software to enable the built-in microphone. For example, you may use Microsoft Sound Recorder.

Modem

Your computer comes with a 56K V.92 internal fax/modem and a phone jack (RJ-11), which is located on the left side of your computer.

Use a telephone cable to connect the computer to the telephone wall outlet.

Connecting the Modem

1. Plug one end of the phone line into the modem port located on the rear side of the computer. (For EMI compliance, you need to clip the included EMI CORE to the phone line.)
2. Plug the other end of the line into the analog phone wall outlet.

Depending on where your computer is used, you may need to change settings in the modem. Correct setting will allow you to maintain a stable connection in a country where its telecommunication system may be different to others.

To change the modem setting, do the following:

1. Go to [Start > Settings > Control Panel] and double-click on Modem Settings icon. You will see a similar dialog box.

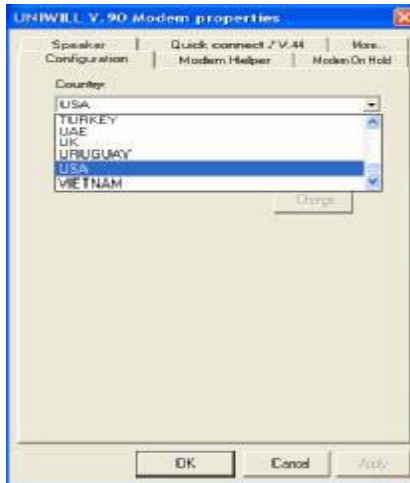

2. Click on the pull-down menu and select the country where it is applicable. Click on OK to exit.

Ethernet

Your computer is equipped with a 10/100Base-TX Fast Ethernet network adapter. Connect the active LAN cable to the RJ-45 LAN port located on the left side of the computer. This allows you to access and transmit data in the local area network.

Connecting to the Network

Use Unshielded Twisted Pair (UTP) Ethernet cable only.

1. Insert one end of the UTP cable into the network connector until the connector snaps securely into the receptacle.
2. Either connect the other end of the cable to an RJ-45 jack wall outlet or to an RJ-45 port on a UTP concentrator or hub in the network.

Cabling Restriction for Networks

The following restrictions should be observed for 100/1000BASE-TX networks:

- The maximum cable run length is 100 meters(m) (328 feet[ft]).
- For 100-Mbps operations, use Category 5 wiring and connections.



Note: Consult Windows manual and / or Novell Netware user's guide for the software installation, configuration, operation of the network.

C H A P T E R ▼ T W O

BIOS SETUP AND SECURITY FEATURE

In this chapter, you will learn how to enter the BIOS Setup Menu and manipulate various hardware control settings. You will also learn how to use the built-in security features.

The Setup Utility is a hardware configuration program built into your computer's BIOS (Basic Input/Output System). It runs and maintains a variety of hardware functions. It is a menu-driven software, which allows you to easily configure and change the settings.

The BIOS contains manufacture's default settings for the computer's standard operations. However, there are occasions when you may be required to modify the default settings in the BIOS. For example, you may need to configure the BIOS power management (APM) settings if you are using DOS, or non-Windows operating system.

The BIOS allows you to set up passwords to limit access to users. This is an important feature because a great deal of vital information is carried within the computer nowadays. Unauthorized access can be prevented. Later in this chapter, you will learn how to use this security feature.

Entering the BIOS Setup Screen

First turn on the power. When the BIOS performs the POST (Power-On Self Test), press F2 key quickly to activate the AMI BIOS Setup Utility.



Note: You may need to press F2 key fairly quickly. Once the system begins to load Windows, you may have to retry by cycle-power on again

Leaving the BIOS Setup Screen

When you have finished modifying the BIOS settings, exit the BIOS. It takes a few seconds to record changes in the CMOS.

BIOS Action Keys

Function Key	Command	Description
ESC	Exit	Leaves a sub-menu to return to the previous menu OR exits the BIOS setup while saving changes.
Enter	Go to Sub Screen	Shows the Sub Menu
F1	General Help	Shows the Help Screen
F9	Default setting	Load Optimal Defaults
F10	Save and Exit	Saves changes and reboots the computer.
<Tab>	Select a field	Selects the next field.
↑	Select an item	Selects the next upper item.
↓	Select an item	Selects the next lower item.
-	Lower value	Selects the next value within a field.
+	Higher value	Selects the next value within a field.

Modifying the BIOS Settings

The AMIBIOS setup main menu is subdivided into sub-menus. Each menu item is described in this section.

Main Setup

Under this menu, you may change time/date and view basic processor and system memory information.

Item	Selections / Sub-menu	Description
Date	N/A	Type in the current date, in MM/DD/YY format.
Time	N/A	Type in the current date, in HH:MM:SS format.

Advanced Setup

Item	Selections / Sub-menu	Description
Internal Modem Support	Enabled Disabled	Enable or disable the built-in modem function.
Mini PCI Wireless LAN	Enabled Disabled	Enable or disable the built-in wireless LAN function (optional).

Security Setup

► Boot Settings Configuration

Item	Selections / Sub-menu	Description
Change Supervisor Password	N/A	Install or Change the Password
Change User Password	N/A	Install or Change the Password
Clear User Password	N/A	Install or Change the Password
Boot Sector Virus Protection	Disabled Enabled	To enable or disable the boot sector protection. When Enabled, BIOS gives a warning when any program attempts to rewrite or delete the boot sector.



Note: About Boot Sector Virus Protection:

If enabled, the following warning message appears when a program attempts to alter the boot sector. You may have to enter "N" several times to prevent the boot sector write.

Boot Sector Write!!!

Possible VIRUS: Continue (Y/N)? _

The following warning message appears when a program attempts to format the hard disk drive.

Format!!!

Possible VIRUS: Continue (Y/N)? _

Using Password Protection

Two Levels of Password Protection are available. The BIOS provides both a Supervisor and a User password. If you try to activate both passwords, the Supervisor password must be set first.

The passwords activate two different levels of protection:

1. System always asks for password every time it is powered on.
2. System asks for password only when you attempt to enter BIOS utility.

The passwords are encrypted and stored in NVRAM. Make sure you write them down or memorize them. If you lost the passwords, the computer may need to be sent back to the factory or to an authorized service dealer to reset the passwords.

Power Setup

Item	Selections / Sub-menu	Description
Intel SpeedStep tech.	Automatic Reversed Battery-Optimized Maximum-Performance Disabled	[Automatic]: CPU adjusts its frequency automatically (on AC power or battery power) to save battery life. [Reversed]: (currently no function) [Battery Optimized]: CPU performance is minimized to save battery life. [Maximum Performance]: CPU performance is maximized. [Disabled]: SpeedStep function is disabled.
Power Button Mode	On/Off Suspend	[On/Off]: When the power button is pressed, the system is turned off. [Suspend]: When the power button is pressed, the system enters the suspend mode.
Long Battery Life Mode	Enabled Disabled	When Enabled, maximum battery life can be achieved. The processor performance is lowered.

High Performance Mode	Enabled Disabled	When Enabled, maximum system performance can be achieved. The processor performance is enhanced.
-----------------------	---------------------	--



Note: The Suspend Mode selection in BIOS only applies to older Windows version (such as Windows 3.1 or Windows 95 or NT4) or non-Windows operating system. In Windows ME / 98SE / 2000 / XP, suspend mode and settings are determined by settings in the Power Options Properties (Start > Control Panel > Power Options).

Note: By default, both the Long Battery Life Mode and High Performance Mode are enabled. In this combination, when the notebook is on AC power, it enters Higher Performance Mode automatically, and when the notebook is on battery power, it enters Long Battery Life Mode.

Boot Setup

► Boot Settings Configuration

Item	Selections / Sub-menu	Description
Quiet Boot	Disabled Enabled	When Enabled, the system will display OEM logo instead of the POST messages. When Disabled, the system will display POST messages (i.e. devices information.)

► Boot Device Priority

Item	Selections / Sub-menu	Description
------	-----------------------	-------------

1st Boot Device	Removable Dev. CD/DVD Hard Drive Realtek Boot Agent Disabled	Set the type of device for the 1st drive BIOS attempts to boot from. If Realtek Boot Agent is selected, system will attempt to load boot sector from the Ethernet port.
2nd Boot Device		Set the type of device for the 2nd drive BIOS attempts to boot from.



Note: If you select Realtek Boot Agent, the system will attempt to boot from the network.

Note: When the BIOS performs POST, you may also press F12 Key to enable the Boot Device selection menu. You may choose CD/DVD, Hard Drive, or Realtek Boot Agent as the first storage device to boot from. If you have already connected a USB Floppy Disk Drive before powering up, it will appear as a Removable Device in the Boot Device selection menu

Exit Setup

Item	Selections / Sub-menu	Description
Saves Changes and Exit	N/A	After you have completed the BIOS settings, select this item to save all settings, exit BIOS Setup utility, and reboot. New system settings will take effect on next power-up. F10 key can be used for this operation.
Discard Changes	N/A	Discards changes done so far to any of the setup questions.
Load Optimal Defaults	N/A	Load Optimal Default value for all the setup questions. F9 key can be used for this operation.

C H A P T E R ▼ T H R E E

BATTERY POWER & POWER MANAGEMENT

In this chapter, you will learn the fundamentals of power management and how to use it to achieve longer battery life.

In this chapter, you will learn how to operate your notebook on battery power, how to handle and maintain the battery pack, and learn about the system's power saving features.

TFT display, central processor, hard disk drive are the major hardware subsystems that consume the most power. Power management deals how these key components should behave to conserve power. For example, you can have the system turn off its display after 2 minutes of inactivity to save power. Efficient power management can help you work longer sessions before having to recharge the battery.

The Battery Pack

Lithium-Ion Battery

Your notebook uses a six-cell or four-cell Lithium-Ion battery pack that provides power when you don't have access to an AC outlet.



Note: It is necessary that you charge the battery pack for at least 6 hours before using it for the first time.

Note: In the Standby Suspend mode, a fully charged battery loses its power in roughly 1/2 day or less. When not being used, the battery's power will deplete in 1-2 month.

Battery Low-Power Warning

1. Low Battery Warning

Low battery condition occurs when battery power is reduced to 6%. The red battery status LED indicator blinks and the system beeps once every 16 seconds or so.

2. Very Low Battery Warning

Very Low battery condition occurs at 3 % power remaining. The red battery status LED indicator blinks and the system beeps at 4-second interval.

When the notebook warns you of its low battery condition, you will have about 3-5 minutes to save your current work.



Warning: Do not expose battery packs to temperatures below 0 degree Celsius (32 degree F) or above 60 degree C (140F). This may adversely affect the battery pack.



Note: Press Fn+F3 to turn off the battery warning beep.

Installing and Removing the Battery Pack

To Remove the Battery Pack:

1. Place the notebook bottom-side up on a flat and secured surface.
2. Slide Latch 1 to the unlocked position
3. Hold Latch 2 to the unlocked position as indicated by the arrow and pull the battery's hard case away from the notebook.

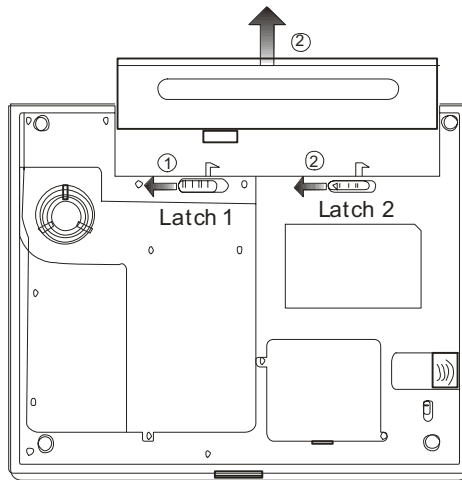

To Install the Battery Pack:

1. Place the notebook bottom-side up on a flat and secured surface.
2. Carefully insert the battery pack into the battery compartment of the notebook and slide Latch 1 to the locked position.

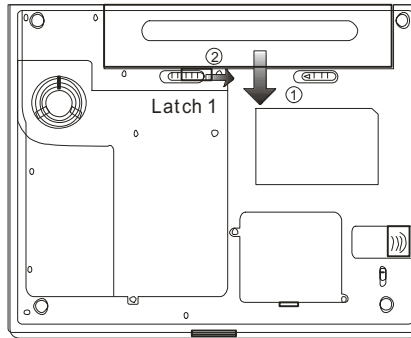

Charging the Battery and Charging Time

To charge the battery, while the battery pack is in the notebook, plug the AC adapter into the notebook and an electrical outlet. The charging time is approximately 4-5.5 hours when the notebook is turned off and approximately 4.5-6 hours when the notebook is turned on.

When the battery is fully charged, the battery charge indicator becomes dark (off).



Note: If system runs at heavy loading or in a high temperature environment, the battery may not be fully charged. You need to continue to charge it with the AC adapter plugged in until the charging LED turns off.

Checking the Battery Level

You can check the remaining battery power in the Windows battery status indicator, which is located at the lower right-hand corner of the task bar. (If you do not see a battery or AC-in icon on the task tray, go to Power Options Properties box and click on the Advanced tab. Check off ``Always show icon on the task bar``.)

Alternatively, you can access the power meter by clicking the Power Options icon in the Windows Control Panel.

Prolonging the Battery's Life and Usage Cycles

There are ways you can do to prolong the use of battery.

- Use the AC adapter wherever AC wall outlet is available. This will ensure uninterrupted computing.
- Purchase additional battery pack.
- Store the battery pack in room temperature. Higher temperature tends to deplete the battery's power faster.
- Make good use of the power management function. Save To Disk (Hibernate) saves the most energy by storing current system contents in a hard disk space reserved for this function.
- The life expectancy of the battery is approximately 300 recharges.
- See the notices section in the beginning of the user manual on how to care for the battery pack.

Note: Read Section Protecting Your Notebook in the beginning of this manual for tips about how to maintain the battery pack.

Note: To achieve optimal battery performance, you may need to do a battery calibration at a 3-month interval. To do this:

1. Fully charge the battery.
 2. Then discharge the battery by entering the BIOS setup screen. (Press F2 key as soon as you turn on the computer. And let it remain at the setup screen until the battery runs out.)
 3. Fully charge the battery again.
-

Using Windows Power Options

Windows Power Management provides basic power saving features. In the Windows Power Options Properties [Start > Settings > Control Panel > Power Options] dialogue box, you may enter time-out values for display and hard disk drive. Windows power manager saves power by turning off hard drive after 1 minute of inactivity, for example.

Windows' Power Schemes

The power management control panel in Windows XP, known as Power Schemes, is designed to provide the user with an easy-to-use interface. The Power Schemes tab can be found in the Power Options Properties panel that is accessible via the control panel window.

Schemes are easy to understand, based on notebook usage scenarios, and control not only processor power usage but other system peripherals as well.

Go to [Start > Settings > Control Panel] and double-click the Power Options icon.

Always on mode puts the processor into maximum performance mode, which provides no power saving. The other schemes control processor performance based on demand. For example, Max Battery mode lowers the processor's speed and voltage to conserve power as much as possible.



In this dialog box, you can manually set the LCD and hard drive's time-out values in the Plugged in column and in the Running on batteries column. Lower time-out values will save more battery power.



Note: Also consult Windows user guide for more information on how to use Windows power management functions.

Note: Actual dialogue box shown above may appear slightly different.

Suspend Mode

Standby Suspend

The system automatically enters this mode after a period of inactivity, which is set in the Power Schemes dialog box. In Standby mode, hardware devices, such as display panel and hard disk, are turned off to conserve energy.

Hibernate Suspend

In this mode, all system data are saved in the hard disk before powering down. When this mode is activated, all system state and contents are saved to the hard disk drive after a period of inactivity defined by the user. No power or very little power is drawn from the battery module under this mode.

However, depending on how much RAM that have been installed on your computer, the amount of time the system requires to restore all its previous contents can range from 5 to 20 seconds.

For Windows 2000 / XP users, hibernation is handled by the operating system; therefore, no special disk partition or disk file is necessary.

If you wish to activate Hibernate mode, you need enable Hibernate Support in the Hibernate tab of the Power Options menu.



Note: Do not install or remove the memory module when the system is in the suspend mode.

Note: Actual dialogue box shown above may appear slightly different.

Power Button Action

The notebook PC's power button can be set to turn off the system or activate the suspend mode.

Go to [Start > Settings > Control Panel > Power Options] and click on the Advanced tab. In the pull-down menu, select how you wish the power button to work as.

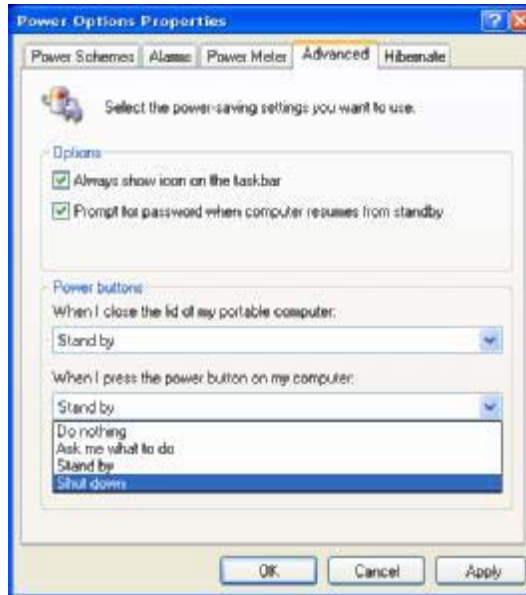

Note: Actual dialogue box shown above may appear slightly different.



Warning: In the *When I close the lid of my portable computer* pull-down menu, DO NOT select *Do nothing* – otherwise the system will still run at high speed while the processor's fan grill is fully blocked by the closed LCD panel. The heat will damage the LCD panel.

Low Battery Warning

You can define when and how the system warns you of its battery-low condition.

Go to the Alarms tab in the Power Options Properties box. If you wish to hear audible beeps, click on the Alarm Action button and put a check on Sound Alarm.

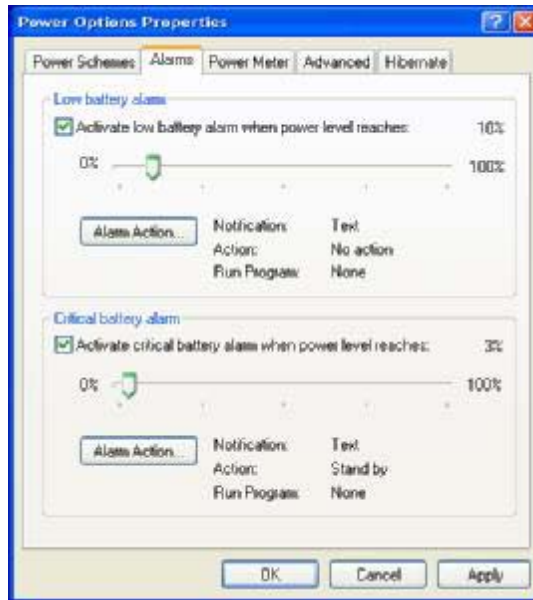

Note: Consult Windows user guide for more information on how to use Windows power management functions.

Note: Actual dialogue box shown above may appear slightly different.

Power Menu Quick Access

Instead of making specific selections in the Power Options Properties box, you can quickly and easily specify which pre-set power saving function you desire by clicking on the Battery icon at the lower right-hand corner of the task bar. (If you do not see a battery or AC-in icon, go to Power Options Properties box and click on the Advanced tab. Check off ``Always show icon on the task bar``.) Select Max Battery if you want the system to enter suspend mode more often. Or, select Always On if your notebook PC is plugged into an AC power source.



Note: Actual dialogue box shown above may appear slightly different.

C H A P T E R ▼ F O U R

UPGRADING YOUR COMPUTER

In this chapter, you will learn how to upgrade the DRAM, hard disk drive, and to install the optional wireless LAN mini PCI.

Upgrading the Hard Disk Drive

Replacing the original drive with one of larger capacity can increase the hard drive capacity of your computer. The computer uses a 9.5 mm (height), 2.5-inch Ultra ATA-66 / 100 / 133 type hard disk.

Be sure to make a backup copy of all your data before attempting this operation.



Warning: Hard drive upgrade is a delicate process. Please observe the following instructions carefully or have a qualified technician install it for you. Damages due to mishandling of this procedure are NOT covered by the manufacture's warranty.



Warning: Apply care when handling the hard disk.

- Do not drop or apply any shock.
 - Do not press on the cover.
 - Do not touch the connector with your fingertips.
 - Mishandling of the hard drive can result in permanent loss of data. Make a backup copy of the drive's content before you remove it.
-



Note: Certain models that come with the IBM-brand hard drive emit a clattering sound when it is being rattled. This is a normal condition.

Upgrading the Hard Disk Drive

To replace the hard disk drive, do the following:

1. Turn OFF the computer. Unhook the AC cord and all cables/devices attached to the notebook.
2. Place your hand on a large metal object momentarily to discharge any static electricity.
3. Locate and remove 8 Screw A's on the System Device Cover.

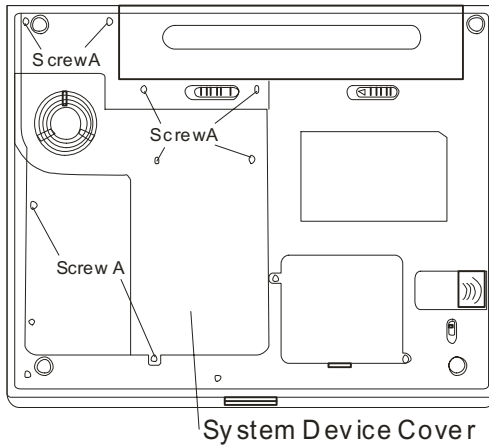

4. Remove the Device Cover.
5. Locate and remove 2 Screw B's. Gently pull the soft tab on the HDD module forward to disengage from the HDD connector and carefully remove the HDD module from the bay.

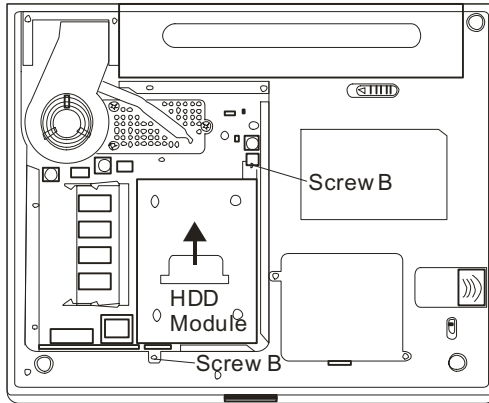

6. Locate and remove 4 Screw C's from the HDD module. Remove the metal case.

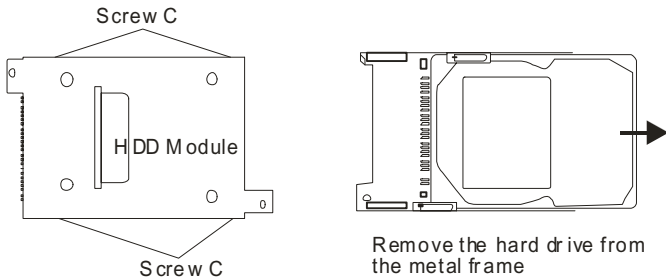

7. Re-attach the metal cover to the new hard drive and tighten 4 Screw C's. Note the green PC board of the hard disk drive is facing against the metal case.
8. Re-insert the HDD module to the HDD connector.
9. Re-attach and tighten 2 Screw B's. (If the HDD assembly is not fully inserted into the bay, the screw and its hole will not line up.)
10. Replace the System Device Cover and 8 Screw A's.

Congratulations! You have now completed the hard drive upgrade. When you boot up the PC, you may need to create a primary HDD partition and reformat the new drive and re-install O/S, drivers, and all the necessary applications.

Upgrading the System Memory

Many applications will generally run faster when the computer's dynamic memory capacity is increased. The computer provides two DDR memory sockets, located underneath the System Device Cover. You can increase the amount of memory by replacing the existing one with a dual inline memory module (commonly known as SO-DIMM) of a higher capacity. The SO-DIMM can be 128MB, 256MB, or 512MB in capacity. The SO-DIMM is of type DDR SDRAM, has 200 pins and runs on 2.5V. The SO-DIMM should be PC2700 compliant.



Warning: Memory upgrade is a delicate process. Please observe the following instructions carefully or have a qualified technician install it for you. Damages due to mishandling of this procedure are NOT covered by the manufacture's warranty.



Warning: Changing memory while your computer is in suspend or power-saving mode may cause permanent damage to the hardware. Make sure you turn off the power and unplug the AC cord before proceeding with a memory upgrade.



Warning: You should only use the DIMM module that is approved by the reseller or the manufacturer; otherwise the system may become unstable.

Installing a memory module (DIMM) into the system

To install the DIMM, do the following:

1. Power OFF the notebook. Unplug the AC cord and all cables/devices attached to the notebook.
2. Place your hand on a large metal object momentarily to discharge any static electricity. Place the notebook on a flat surface and fully open the LCD lid.
3. Locate and remove 8 Screw A's on the Metal Cover.

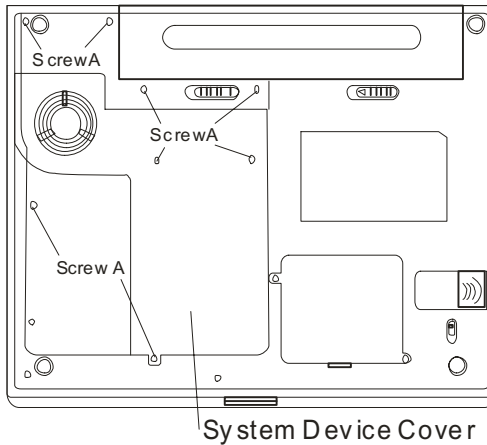

4. Remove the Metal Cover. The DIMM socket is now seen as shown below.

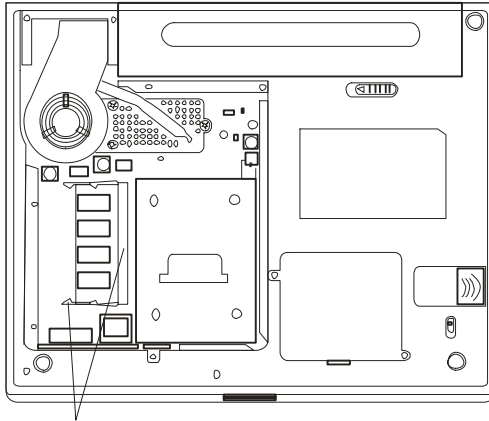

Double Deck DDR Slot

5. If you need to remove an old DIMM from the socket, press out on the latches located on both edges of the socket at the same time. The DIMM should pop up to an angle of 30 degree (see diagram below.). Pull the DIMM module out of the memory socket. Store away the DIMM for the future use.

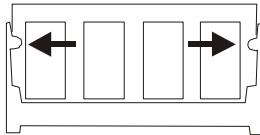

6. Install the new DIMM module into the memory socket. The DIMM will only fit in one orientation. Insert the DIMM at an angle of approximately 30 degrees into the empty memory socket. Then press it firmly so that the contact edge is driven into the receiving socket.

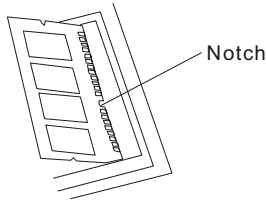

7. Pivot the DIMM until the latches on both sides of the socket snap into place.



Note: Notice the notch on the DIMM. The notches should fit nicely with the socket.

8. Replace the System Device Cover and 8 Screw A's.

Congratulations! You have just completed the memory upgrade. When you boot up the computer, you should expect to see an increase in DRAM capacity.



Note: Your computer has been tested with a wide range of DIMM on the market. However, not all memory modules are compatible. Check with your system vendor for a list of compatible DIMM for your computer.

Adding a Mini-PCI Type Wireless LAN Card (Optional Device)

Your computer comes with a unique Mini PCI Card socket, which is located next to the DRAM socket and underneath the WLAN Module Cover. The socket allows the computer to add unique features such as wireless LAN (IEEE802.11x). Ask your dealer on the availability of the mini PCI card.



Warning: Installing a mini PCI card is a delicate process. Please observe the following instructions carefully or have a qualified technician install it for you. Damages due to mishandling of this procedure are NOT covered by the manufacture's warranty.



Warning: Installing the mini PCI card while your computer is in suspend or power-saving mode may cause permanent damage to the hardware. Make sure you turn off the power and unplug the AC cord before proceeding with a memory upgrade.

Installing a Mini PCI Card into the System

To install a new Mini PCI card, do the following:

1. Power OFF the notebook. Unplug the AC cord and all cables/devices attached to the notebook.
2. Place your hand on a large metal object momentarily to discharge any static electricity. Place the notebook on a flat surface and fully open the LCD lid.
3. Locate and remove 2 Screw D's on the WLAN Module Cover.

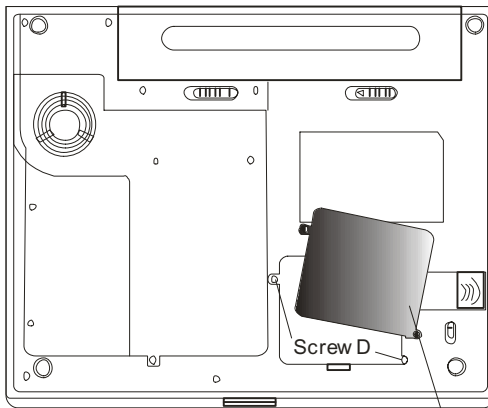

WLAN Module Cover

2. The mini PCI card will only fit in one direction. Align the small notch in the module with the socket on the connector and insert the card at an angle of approximately 30 degrees into the empty socket. Then press it firmly so that the contact edge is driven into the receiving socket. Pivot the mini PCI card until the latches on both sides of the socket snap into place.



Note: If you want to remove a mini PCI card from the socket, press out on the latches located on both edges of the socket at the same time. The card should pop up to an angle of 30 degree.

3. Locate 2 antenna cables with connectors. Snap the cable onto the golden connector on the Mini PCI Wireless LAN card. *(Note: The connectors are fairly small! This may take some maneuvering. You may want to connect the antenna cables before inserting the wireless card into the socket.)*

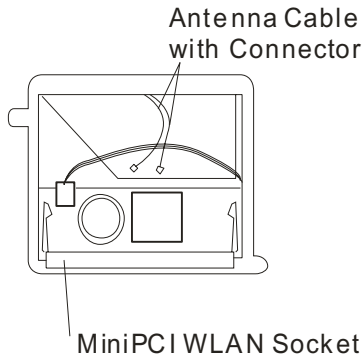

4. Replace the WLAN Module Cover and 2 Screw D's.

Congratulations! You have now completed the mini PCI card installation. During the next time the system boots to Windows, the system will prompt for driver location. Insert the Factory CD-ROM and point to the directory where the Wireless LAN driver can be found. In addition to installing the driver, you may also need to run a Setup.exe program to install the card's utility applications before it is fully operational.

C H A P T E R ▼ F I V E

TROUBLE SHOOTING

In this chapter, you will learn how to solve common hardware and software problems.

Your computer has been fully tested and complies with the system specifications before shipping. However, incorrect operations and/or mishandling may cause problems.

This chapter provides a reference for identifying and correcting common hardware and software problems that you may encounter.

When you encounter a problem, you should first try to go through the recommendations in this chapter. Instead of returning the computer and waiting for repair, you may easily solve the problems by considering the following scenarios and possible solutions. If the error continues, contact your reseller for service information.

Before taking further actions, consider the following suggestions:

- Check to see if the problem persists when all the external devices are removed.
- Check to see that the green light indicator on the AC adapter is lit.
- Check to see the power cord is properly plugged to the wall outlet and to the computer.
- Check to see the power indicator of the computer is on.
- Check to see if your keyboard is operational by pressing and holding any key.
- Check for any incorrect or loose cable connections. Make sure the latches on the connectors latch securely on to the receptor end.
- Be sure you have not performed an incorrect setting on the

hardware devices in the BIOS Setup utility. A faulty setting may cause the system to misbehave. If you are not sure of the changes you made, try to restore all the settings to factory defaults.

- Be sure all the device drivers are installed properly. For example, without the audio driver properly installed, the speakers and microphone will not work.
- If external devices such as USB camera, scanner, printer do not function correctly when connected to the system, it is usually the device's own problem. Consult the device's manufacturer first.
- Some software programs, which have not gone through rigorous coding and testing, may cause problems during your routine use. Consult the software vendor for problem solving.
- Legacy peripheral are not plug-and-play capable. You need to restart the system with these devices powered up and connected first.
- Be sure to go to BIOS SETUP and load DEFAULT SETTING after BIOS re-flash.
- Be sure the Quick Key Lockout Switch on the bottom of the computer is not engaged; otherwise the quick keys will not work.

Audio Problems

No speaker output -

- Turn up the volume dial located at the right edge of the computer. See Chapter 1 for its location.
- Software volume control is turned down in Microsoft Sound System or is muted. Double-click the speaker icon on the lower right corner of the taskbar to see if the speaker has been muted or turned down all the way.
- Most audio problems are software-related. If your computer worked before, chances are software may have been set incorrectly.
- Go to [Start > Settings > Control Panel] and double-click the Sounds and Audio Devices icon. In the Audio page, make sure that VIA AC'97 Audio (WAVE) is the default playback device.

Sound cannot be recorded -

- Double-click the speaker icon on the lower right corner of the taskbar to see if the microphone has been muted.
 1. Click Options and select Properties.
 2. Select Recording and click the OK button.
 3. After Click OK button, the recording volume control panel will appear.
- Go to [Start > Settings > Control Panel] and double-click the Multimedia icon (or Sounds and Audio Devices icon). In the Volume or Audio page, make sure that VIA AC'97 Audio (WAVE) is the default recording device.

Hard Disk Problems

The hard disk drive does not work or is not recognizable -

- If you had just performed a hard disk upgrade, make sure the hard drive connector is not loose and the hard disk drive is also correctly seated. Remove it and reinsert it firmly, and restart your PC. (Refer to Chapter 4 for details.)
- The new HDD may need to be partitioned and reformatted. O/S and drivers will need to be re-installed as well.
- Check the hard disk indicator LED. When you access a file, the LED lamp should light up momentarily.
- The new HDD may be defective or is not compatible.
- If your computer has been subjected to static electricity or physical shock, you may have damaged the disk drive.

The hard drive is making abnormal whining noises -

- You should back up your files as soon as possible.
- Make sure the source of noise is indeed from the hard drive and not the fan or other devices.

The hard disk drive has reached its capacity -

- Run Disk Cleanup utility in Windows. [Start > All Programs > Accessories > System Tools > Disk Cleanup] The system will prompt you for what to do.
- Archive files or programs that you had no longer used by moving them to an alternative storage medium (floppy disk, optical record-able disk, etc.) or uninstall programs that no longer use.
- Many browsers store files in the hard drive as a cache to speed up the performance. Check the program's Online Help

for instructions on decreasing the cache size or on removing temporary Internet files.

- Empty the Recycle Bin to create more disk space. When you delete files, Windows saves them to the Recycle Bin.

The hard disk takes longer to read a file -

- If you have been using the drive for a period, the files may be fragmented. Go to [Start > Programs > Accessories > System Tools > Disk Defragmenter] to perform a disk defragmentation. This operation may take a while.
- Interrupt requests or problems with other hardware devices may have occupied the CPU and therefore slows down the system performance.

The files are corrupted -

- Run the Error-checking utility in Windows to check the HDD. Double-click My Computer. Right-click C: and select Properties. Click Check Now in Error-checking in Tools.

Optical Drive Problems

The optical drive does not work -

- Try rebooting the system.
- The disk is damaged or files are not readable.
- After you have inserted a CD-ROM disk, it may take a moment before you can access its content.

The drive dose not read any disks -

- The CD may not be properly seated in the tray. Make sure the disk is firmly seated onto the spindle.
- The disk is damaged or not readable.

The disk cannot be ejected -

- Normally, it takes a few seconds to eject the disk.
- If the disk cannot be ejected, it may be mechanically jammed. Straighten out a paper clip and insert it to a tiny hole next to the eject button. This should reject the disk tray. If not, return the unit for repair. Do not forcefully pull on the disk tray.

The Combo or DVD RW drive (optional device) cannot record -

- You need to purchase and install a burner utility program to record files to a blank media.

Display Problems

The display panel is blank when the system is turned on -

- Make sure the computer is not in the Standby or Hibernate suspend modes. The display is turned off to conserve energy in these modes.

The screen is difficult to read -

- The display resolution should at least be set to at least 1024x768 for optimal viewing.
 1. Go to [Start > Settings > Control Panel] and double-click the Display icon.
 2. Under the Settings page, set screen resolution to at least 1024x768 and choose at least 256 colors.

The screen flickers -

- It is normal if the display flickers a few times during shutting down or powering up.

Keyboard and Mouse Problems

The built-in touch pad performs erratically -

- Make sure there is no excess perspiration or humidity on your hand when using the touch pad. Keep the surface of the touch pad clean and dry.
- Do not rest your palm or wrist on the surface of the touch pad while typing or using the touch pad.

The built-in keyboard accepts no input -

- If you are connecting an external keyboard to the system, the built-in keyboard may not work.
- Try restarting the system.

The characters on the screen repeat while I type.

- You may be holding the keys down too long while you're typing.
- Keep the keyboard clean. Dust and dirt under the keys could cause them to stick.
- Configure the keyboard to wait longer before the auto repeat feature starts. To adjust this feature, Go to [Start > Settings > Control Panel], and double-click the Keyboard icon. A dialogue box shows up with the adjustable settings for the keyboard.

CMOS Battery Problem

A message “CMOS Checksum Failure” displays during the booting process or the time (clock) resets when booting -

- Try to reboot the system.
- If the message “CMOS Checksum Failure” appears during the booting procedure even after rebooting, it may indicate failure of the CMOS battery. If so, you need to replace the battery. This battery normally lasts two to five years. The battery is of type CR2032 (3V). You may replace it by yourself. The battery is located next to the MiniPCI WLAN Module socket. See Chapter 4 on how to access the WLAN Module socket.

Memory Problems

The POST does not show an increased memory capacity when you have already installed additional memory -

- Certain brands of memory module may not be compatible with your system. You should ask your vendor for a list of compatible DIMM.
- The memory module may not be installed properly. Go back to Chapter 4 to review the details of this operation.
- The memory module may be defective.

The O/S issues an insufficient memory error message during operation -

- This is often a software or Windows-related problem. A program is draining the memory resources.
- Close the application programs you're not using and restart the system.
- You need to install additional memory module. For instructions, go to Chapter 4 Upgrading Your Computer.

Modem Problems

The built-in modem does not respond -

- Make sure the modem driver is loaded properly.
- Go to [Start > Settings > Control Panel > Phone and Modem Options] and go to Modems tab. Make sure SmartLink 56K Voice Modem or Uniwill V.92 Modem is listed. Otherwise, click the Add button to add the modem drive, which is located in the factory CD-ROM (or floppy diskette).
- Go to [Start > Settings > Control Panel > System] and click Device Manager button in the Hardware page to check for possible resource or driver conflict. See Windows on-line help or manual for how to handle such problems.
- Make sure the phone line, which the computer is connected to, is working.

Connection difficulties -

- Be sure to disable Call Waiting on the phone line.
- Be sure to have the correct country setting where your computer is used. [Start > Settings > Control Panel > Modem Settings > Configuration] In the Country/Area pull-down menu, select the appropriate country setting.
- Excessive line noise might cause the connection to be dropped. To check this, put the regular phone handset on the line and placing a phone call. If you do hear abnormal noise, try to make the modem connection with a different line or contact your local telephony company for service.
- Make sure the cable connection is firm.
- Try a different receiver number and see if the problem persists.

Network Adapter / Ethernet Problems

The Ethernet adapter does not work -

- Go to [Start > Settings > Control Panel > System > Hardware > Device Manager]. Double-click on Network Adapters and check if Intel Gigabit PCI Fast Ethernet Adapter appears as one of the adapters. If it does not exist, Windows has not detected the Intel Gigabit Fast Ethernet adapter or the device driver has not been installed properly. If there is a yellow mark or red-cross on the network adapter, it may be a device or resource conflict. Replace or update the device driver from the factory CD-ROM disk or consult Windows manual on how to solve the resource conflict problem.
- Make sure the physical connections on both ends of the cable are good.
- The hub or concentrator may not be working properly. Check to see if other workstations connected to the same hub or concentrator is working.

The Ethernet adapter does not appear to operate in the 100Mbps transmission mode -

- Make sure the hub you are using supports 100Mbps operation.
- Make sure that your RJ-45 cable meets the 100Base-TX requirements.
- Make sure the Ethernet cable is connected to the hub socket that supports 100Base-TX mode. The hub may have both 100Base-TX and 100Base-T sockets.

PC Card / PCMCIA Problems



Note: Some system may not have the PC Card Slot option.

PC Cards do not function-

- Make sure you have properly installed the driver for the card.
- Consult the card's manual or contact the vendor for trouble-shooting.

The PC card cannot be recognized -

- Windows NT4.0 does not support PCMCIA (PC Card) function. You may need an external program for this.
- Make sure the card is fully inserted; the outer end of the card should be even with the edge of the computer.
- Remove and insert the PC card again.
- Make sure there is no IRQ conflict with the card. See Windows on-line help for solving IRQ conflicts.
- Reboot the computer and see if the problem persists.
- The card may be defective. Try the card on another system, if possible.

Windows crashes or freezes when you remove the PC card-

- Make sure you have <Stop> the PC card before removing it. Double-click the Safely Remove Hardware icon at the lower right corner of the task bar and select the card you wish to stop. When you click <Close>, in few seconds Windows will prompt you to remove the card.

Performance Problems

The computer becomes hot -

- In a 35°C environment, the certain areas of the computer's back case are expected to reach 50 degrees.
- Make sure the air vents are not blocked.
- If the fan does not seem to be working at high temperature (50 degrees Celsius and up), contact the service center.
- Certain programs that are processor-intensive may increase the computer temperature to a degree where the computer automatically slows down its CPU clock to protect itself from thermal damage.

The program appears stopped or runs very slowly -

- Press CTRL+ALT+DEL to see if an application is still responding.
- Restart the computer.
- This may be normal for Windows when it is processing other CPU-intensive programs in the background or when the system is accessing slow-speed devices such the floppy disk drive.
- You may be running too many applications. Try to close some applications or increase system memory for higher performance.
- The processor may have been overheated due to the system's inability to regulate its internal heat. Make sure the computer's ventilation grills are not blocked.

Firewire (IEEE1394) and USB2.0 Problems

The USB device does not work -

- Windows NT 4.0 does not support USB protocols
- Check the settings in the Windows Control Panel.
- Make sure you have installed the necessary device drivers.
- Contact the device vendor for additional support.

The IEEE1394 port does not work -

- Go to [Start > Settings > Control Panel > System > Hardware > Device Manager]. You should see an entry which reads "Texas Instrument OHCI Compliant IEEE 1394 Host Controllers". If it does not exist, Windows has not detected the host controller or the device driver has not been installed properly. If there is a yellow mark or red-cross on the 1394 host controller, it may be a device or resource conflict. Replace or update the device driver from the factory CD-ROM disk or consult Windows manual on how to solve the resource conflict problem.
- Make sure the cable is fully connected.
- Make sure you have installed the necessary device drivers.
- Contact the device vendor for additional support.

A P P E N D I X ▼ A

PRODUCT SPECIFICATION

▼ Processor and Core Logic

- Processor
- Core Logic

Mobile Intel Pentium M (Banias), 1.5GHz-1.6GHz, 1 MB L2 with Error Correction Code
 Mobile Intel Pentium M (Dothan), 1.7GHz-2.0GHz, 2 MB L2 with Error Correction Code
 Intel 855GME + ICH4M(FW82801DBM) chipset with graphic, audio, modem, and USB2.0 controllers integrated
 400 MHz Front Side Bus
 266/333 MHz DDR interface

▼ System Memory

- Memory Type
- Default Memory Expansion

DDR SDRAM 333, PC2700 compatible
 128 / 256 / 512, 2.5-Volt 64-bit bus
 Two 200-pin DIMM sockets, Max 1 GB

▼ Display

- LCD Panel
- Graphic Accelerator
- AGP Bus
- Motion Playback
- Frame Buffer
- Other Features
- S-Video TV-out Encoder

12.1-inch (1280x800) WXGA or 12.1-inch (1024x768) XGA active-matrix TFT display with 24-bit colors
 Intel Integrated Extreme Graphic2 2D / 3D graphics accelerator
 4X AGP architecture graphics capability
 Hardware Motion Compensation and IDCT Supported for MPEG1/2 Playback
 Shared Memory Architecture
 Direct3D compatible, DirectX compatible

CH7011

- Chipset
- Audio Codec
- Sound Capabilities

▼ Audio

Intel (ICH4M) integrated audio controller
VT1612A
DirectSound 3D, EAX 1.0 & 2.0 compatible
A3D, I3DL2 compatible
AC97 V2.3 compatible
2 or 4 Stereo Speakers

- Chipset
- Transmission Rate

▼ Modem

Intel (ICH4M) integrated Modem Controller with MDC card, AC97 V2.2 Modem support
V.92 / V.90 / K56flex for download data speed up to 56Kbps.
V.34, V.17, V.29 protocol supported

- Chipset
- PnP Function
- Flow Control
- Speed Selection
- Other Features

▼ LAN / Ethernet

Realtek RTL8100CL Ethernet function for 10/100Base-TX network standards
Windows 2000 / XP Plug and Play compatible
Automatic Jam and auto-negotiation for flow control
Auto Negotiation and Parallel detection for automatic speed selection (IEEE 802.3u)
High performance 32-bit PCI bus master architecture with integrated DMA controller for low CPU and bus utilization
Remote Wake-up Scheme supported
Hot Insertion supported

- Chipset
- Capabilities

▼ Firewire IEEE1394(a)

TI TSB43AB22A IEEE1394 OHCI Host Controller and
Up to 400 Mbps
Expandable up to 63 devices in chains
(Note: In some models, Firewire/1394 function may not be available.)

- Hard Drive
- Combo Drive
- DVD±R/±RW or DVD-Dual or DVD-Multi Standards

▼ Storage

2.5-inch format hard disk drive
5.25-inch format (12.7mm height) fixed module
(Optional Purchase)
5.25-inch format (12.7mm height) fixed module
(Optional Purchase)

- Keyboard
- Touch pad

▼ Keyboard & Touch pad

86-key QWERTY keyboard with embedded numeric keypad and Windows keys, 19.05mm Pitch
Built-in Touch Pad

- Chipset
- PC Card
- 4-in-1 Card Reader Format Support

▼ PC Card & Multiple Card Reader

TI PC1410 (PC Card), Genesis GL817E (Card Reader)
Single Slot TYPE II, Hot insertion and removal supported
Multimedia Card (MMC), Secure Digital Card (SD), Memory Stick (MS), and MS Pro Card
(Note: In some models, PC Card and Multiple Card Reader functions may not be available.)

▼ Ports and Connectors

- Mic-In Port
- Audio-Out/SPDIF
- Firewire
- USB2.0 Port
- Ethernet
- Modem
- S-Video
- Power-In
- VGA Port
- Card Reader
- PC Card Slot

One Microphone-in jack
 One Headphone / SPDIF jack
 One Firewire (IEEE1394) host connector
 Two USB2.0-compliant connectors
 One standard network Ethernet connector (RJ-45)
 One modem / phone connector (RJ11)
 One S-video (TV-out) output connector
 One DC-in connector
 One 15-pin VGA connector
 One 4-in-1 Card Reader slot
 One PC Card Slot (type II)
(In some models, SPDIF-out Jack, Firewire/1394 Port, PC Card Slot, and Card Reader may not be available.)

▼ Battery Pack / AC Adapter

- Primary Battery Pack
- Feature
- Adapter AC-Input / DC-Output

Li-ion 6-Cell pack, 11.1V x 4000 mAh or
 Li-ion 6-Cell pack, 11.1V x 4400 mAh or
 Li-ion 4-Cell pack, 14.8V x 2200 mAh
 Low battery state with low battery warning beep
 SmartPower1&2
 Smart Battery Compliant; low battery warning beep
 Autosensing AC-in 100~240V, DC-out 20V, 65W



Note: For SmartPower 2 to work correctly, the system must be installed with Windows XP SP2 or later edition.

▼ **BIOS**

- PnP Function
- Self Test
- Auto Detection
- Power Management
- Security
- Other Features

AMI PnP BIOS
Power On Self Test
DRAM auto-detection, auto-sizing
L2 Cache auto-detection
Hard disk type auto-detection
APM 1.2 (Advanced Power Management) &
ACPI 2.0 (Advanced Configuration Power Interface)
Two Level Password Protections
32bit access, Ultra DMA, PIO5 Mode support
Multi-boot capability

- O/S

Compatible with Microsoft Windows 2000 / XP / DOS

▼ **Physical Specification**

- Dimension
- Weight
- Environmental Limits

292 (W) x 230 (D) x 25-36 (H) mm
4.18 lbs / 1.9 KG (with 12"LCD, DVD-ROM Drive, and
4-cell battery pack)
Operating Temperature: 5 to 30°C (41 to 86°F)
Operating Humidity: 20 to 90 percent RH (5 to 35°C)
Storage Temperature: -20 to 50°C (-4 to 122°F)

A P P E N D I X ▼ B

AGENCY REGULATORY NOTICES

Federal Communications Commission Notice

This equipment has been tested and found to comply with the limits for a Class B digital device, pursuant to Part 15 of the FCC Rules. These limits are designed to provide reasonable protection against harmful interference in a residential installation. This equipment generates, uses, and can radiate radio frequency energy and, if not installed and used in accordance with the instructions, may cause harmful interference to radio communications. However, there is no guarantee that interference will not occur in a particular installation. If this equipment does cause harmful interference to radio or television reception, which can be determined by turning the equipment off and on, the user is encouraged to try to correct the interference by one or more of the following measures:

- Reorient or relocate the receiving antenna.
- Increase the separation between the equipment and the receiver.
- Connect the equipment into an outlet on a circuit different from that to which the receiver is connected.
- Consult the dealer or an experienced radio or television technician for help.

Modifications

The FCC requires the user to be notified that any changes or modifications made to this device that are not expressly approved by the Manufacturer may void the user's authority to operate the equipment.

Connections to Peripheral Devices

Connections to this device must be made with shielded cables with metallic RFI/EMI connector hoods to maintain compliance with FCC Rules and Regulations.

Declaration of Conformity

This device complies with Part 15/68 the FCC Rules. Operation is subject to the following two conditions: (1) this device may not cause harmful interference, and (2) this device must accept any interference received, including interference that may cause undesired operation.

European Notice

Products with the CE Marking comply with both the EMC Directive (89/336/EEC) and the Low Voltage Directive (73/23/EEC) and R&TTE Directive (1999/5/EC) issued by the Commission of the European Community.

Compliance with these directives implies conformity to the following European Norms:

- EN55022 (CISPR 22) Radio Frequency Interference
- EN50082 (IEC801-2, IEC801-3, IEC801-4) Electro-magnetic Immunity
- EN 300 328-2, EN 300 328-1, EN 301 489-1, EN 301 489-17 (ETSI 300 328, ETSI 301 489) Electro-magnetic Compatibility and Radio Spectrum Matter.
- TBR21 (ETSI TBR21) Terminal Equipment.
- EN60950 (IEC950) I.T.E. Product Safety

Canadian Notice

This digital apparatus does not exceed the Class B limits for radio noise emissions from digital apparatus as set out in the radio interference regulations of the Canadian Department of Communications.

Le present appareil numerique nemet pas de bruits radioelectriques depassant les limites applicables aux appareils numeriques de Classe B prescrites dans le reglement sur le brouillage radioelectrique edicte par le Ministere des Communications du Canada.

Power Cord Requirement

The power cord supplied with the AC adapter should match the plug and voltage requirements for your local area. Regulatory approval for the AC adapter has been obtained using the power cord for the local area. However, if you travel to a different area and need to connect to a different outlet or voltage, you should use one of the power cords listed below. To purchase a power cord (including one for a country not listed below) or a replacement ac adapter, contact your local dealer.

U.S. and Canada

- The cord set must be UL-Listed and CSA-Certified or C-UL Listed.
- The minimum specifications for the flexible cord are (1) No. 18 AWG, (2) Type SJ, and (3) 3-conductor.
- The cord set must have a rated current capacity of at least 10 A.
- The attachment plug must be an earth-grounding type with a NEMA 5-15P (15A, 125V) or NEMA 6-15P (15 A, 250V) configuration.

Japan

- All components of the cord set (cord, connector, and plug) must bear a 'PSE' mark and registration number in accordance with the Japanese Dentori Law.
- The minimum specification for the flexible cord are: (1) 0.75 mm² conductors, (2) Type VCT or VCTF, and (3) 3-conductor.
- The cord set must have minimum rated current capacity of 7 A.

- The attachment plug must be a two-pole, grounded type with a Japanese Industrial Standard C8303 (15 A, 125 VAC) configuration.

Other Countries

- The cord set fittings must bear the certification mark of the agency responsible for evaluation in a specific country. Acceptable agencies are:

- BSI (UK)
- OVE (Australia)
- CEBEC (Belgium)
- SEMKO (Sweden)
- FIMKO (Finland)
- DEMKO (Denmark)
- NEMKO (Norway)
- SETI (Finland)
- EANSW (Australia)
- SEV (Switzerland)
- IMQ (Italy)
- UTE (France)
- CCC (China)
- PSB (Singapore)
- PSE (Japan)
- BSMI (Taiwan)
- B (Polish)
- VDE (Germany)
- SASO (Saudi Arabia)

- The flexible cord must be of a HAR (harmonized) type HO5VV-F 3-conductor cord with a minimum conductor size of 0.03 square inches.
- The minimum specification for the flexible cord for Class II product are: (1) 2X0.75 mm² conductors, (2) 2-conductor cord.
- The cord set must have a current capacity of at least 10 A and a nominal voltage rating of 125 / 250 VAC.

CAUTION: MODEL 223XIY IS DESIGNED TO USE WITH THE FOLLOWING AC ADAPTER MODEL ONLY

Manufacture: LITE-ON ELECTRONICS, INC.; LI SHIN INTERNATIONAL ENTERPRISE CORP.; HIPRO CORP.

Model: PA-1650-08 (65W); 0335A2065 (65W);HP-OK065E13 (65W)

Telephone lines requirement

- The appropriate utilization of 26AWG telephone line cord on unit.
CAUTION: Always disconnect all telephone lines from the wall outlet before servicing or disassembling this equipment.
CAUTION: To reduce the risk of fire, use only No. 26AWG or larger telecommunication line cord.

Battery Pack Safety

- The battery pack is intended to use only with this notebook.
- Do not disassemble the pack.
- Do not dispose of the battery pack in fire or water.
- To avoid risk of fire, burns, or damage to your battery pack, do not allow a metal object to touch the battery contacts.
- Handle a damaged or leaking battery with extreme care. If you come in contact with the electrolyte, wash the exposed area with soap and water. If it contacts the eye, flush the eye with water for 15 minutes and seek medical attention.
- Do not charge the battery pack if the ambient temperature exceeds 45°C (113°F).
- To obtain a replacement battery, contact your local dealer.
- Do not expose the battery pack to high storage temperatures (above 60°C, 140°F).
- When discarding a battery pack, contact your local waste disposal provider regarding local restrictions on the disposal or recycling of batteries.
- Use only supplied AC Adapter for charging.

CAUTION: Danger of explosion if battery is incorrectly replaced. Replace only with same or equivalent type recommended by the manufacturer.
Discard used batteries according to the manufacturer's instructions or local laws.

VORSICHT! Explisionsgefahr bei unsachgemäßen Austausch der Batterie.
Ersatz nur durch denselben oder einem vom Hersteller empfohlenem ähnlichen Typ. Entsorgung gebrauchter Batterien nach Angaben des Herstellers.

Laser Safety

The optical drive used with this computer is certified as a Class 1 laser device according to the U.S. Department of Health and Human Services

(DHHS) Radiation Performance Standard and International Standards IEC 825 / IEC 825-1 (EN60825 / EN60825-1). The device is not considered harmful, but the following precautions are recommended:

- Do not open the unit.
- Avoid direct exposure to the laser beam.
- If the unit requires service, contact an authorized service center.
- Ensure proper use by reading and following the instructions carefully.
- Do not attempt to make any adjustment of the unit.

CLASS 1 LASER PRODUCT
APPAREIL A LASER DE CLASSE 1
LASERSCHUTZKLASSE 1 PRODUKT

Warning!

Do not attempt to disassemble the cabinet containing the laser. The laser beam used in this product is harmful to the eyes. The use of optical instruments, such as magnifying lenses, with this product increase the potential hazard to your eyes. For your safety, have this equipment serviced only by an authorized service provider.

Lithium battery warning / Bridge battery warning

This computer contains a lithium battery to power the clock and calendar circuitry.

CAUTION: Danger of explosion if battery is replaced incorrectly. Replace only with the same or equivalent type recommended by the manufacturer. Discard used batteries according to the manufacturer's instructions.

ATTENTION: Il y a danger d'xplosion s'il y a remplacement incorrect de la batterie. Remplacer uniquement avcc unc batterie du meme type ou d'un type recommande par le constructeur. Mettre au rebut les batteries usagees conformement aux instructions du fabricant.

VORSICHT! Explosionsgefahr bei unsachgemBen Austausch der Batterie Ersatz nur durch denselben oder einem vom Hersteller empfohlenem ahnlichen Typ. Entsorgung gebrauchter Batterien nach Angaben des Herstellers.

Der Arbeitsplatzbezogene Schalldruckpegel nach DIN 45 635 betragt 70dB (A) oder weniger.

Zum Netzanschlus dieses Gerates ist eine geprüfte Leitung zu verwenden. Fur einen Nennstrom bis 6A und einem Gerategewicht groBer 3kg ist eine Leitung nicht leichter als (1)H05VV-F, 3G, 0.75mm² (2)2X0.75 mm² conductors einzusetzen.

Die Steckdose muB nahe dem Gerat angebracht und leicht zuganglich sein.

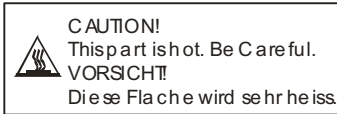

When you see this symbol, be careful as this spot may be very hot.

A P P E N D I X ▼ C

USING THE BLUETOOTH MODULE

Software Installation:

The software installation package of the Bluetooth module is located in the Bluetooth CD disc.

If you are inserting the Bluetooth module into notebook for the first time, the system will prompt you for driver. Put in the Bluetooth CD disc into the optical drive and follow the on-screen instructions to install the Bluetooth driver and utility program properly.

Hardware Installation:

Plug the Bluetooth module into the slot next to the optical drive on the bottom of the notebook. Remember to put the latch to the locked position to lock the module in place.

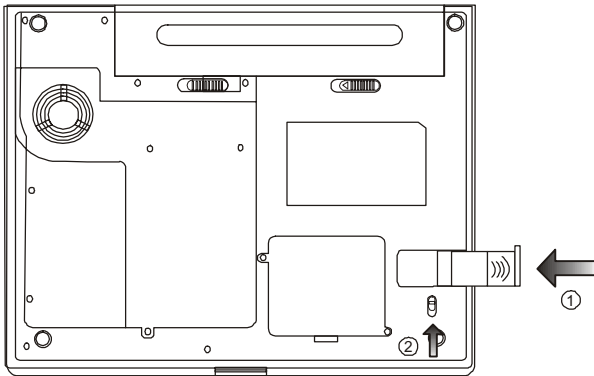



General Tips on Using Bluetooth Functions:

- *The Bluetooth Tray*
 The Bluetooth tray resides in the Windows system tray, which is located in the lower-right corner of the screen. The Bluetooth tray provides fast access to most Bluetooth operations.
 From the Bluetooth tray you can:
 - ◆ *Access My Bluetooth Places:* Double-click the Bluetooth icon, or right-click the Bluetooth icon and then select Explore My Bluetooth Places.
 - ◆ *Access the Bluetooth Setup Wizard.* This wizard will help you:
 - Configure how this computer accesses a service on another Bluetooth device
 - Locate remote Bluetooth devices
 - Configure the way that this computer provides services to remote Bluetooth devices
 - Set the name and type of this Bluetooth device, e.g., 'John's PC', 'Desktop'.
 - ◆ *Access the Bluetooth Configuration Panel*
 Right-click the Bluetooth icon, and then select Advanced Configuration.
 - ◆ *Access the Quick Connect option*
 Right-click the Bluetooth icon, select Quick Connect, and then select the type of service to which you wish to connect.
 - ◆ *Start/Stop Bluetooth on this computer*

- *Icons Used For Bluetooth Devices and Services*
 Bluetooth icons provide at-a-glance feedback about a device or service's status by changing appearance.
 The Bluetooth icon in the Windows system tray provides

feedback about Bluetooth status.

Bluetooth Icon Indicates Bluetooth Status		
Enabled	Disabled	Connected
		
Blue with White	Blue with Red	Blue with Green

- Create A Connection Using The Bluetooth Setup Wizard
 - ◆ From the Folders pane of Windows Explorer, right-click My Bluetooth Places and select Bluetooth Setup Wizard. Or,
 - ◆ In Windows Explorer, with My Bluetooth Places selected, from the Bluetooth menu, select Bluetooth Setup Wizard, Or.
 - ◆ From the Windows system tray: right-click the Bluetooth icon and select Bluetooth Setup Wizard. Follow the wizard's on-screen instructions.

- Find Bluetooth Devices

Search for Devices looks for Bluetooth devices in the vicinity and displays the devices that it finds in My Bluetooth Places. To start a search for devices, in the Folders pane of My Bluetooth Places, select Entire Bluetooth Neighborhood, and then, from the Bluetooth menu, select Search for Devices. The Bluetooth menu is only visible when My Bluetooth Places is active.

- Find A Service

The process of determining the services that a device provides is called Service Discovery. To initiate a Service Discovery, in the Folders pane of My

Bluetooth Places, right-click a device name and select Discover Available Services from the shortcut menu.

Bluetooth services are those things that this computer can do for remote Bluetooth devices. For example, if this computer allows a remote Bluetooth device to send a fax using a fax modem that is physically attached to this computer, then this computer is providing the Bluetooth fax service.

Some services are hardware dependant; this computer cannot provide the fax service unless it has a physical fax modem, for example.



Note: For detailed Bluetooth operations, use the Help button on the Bluetooth application dialogue box.

computer boots to the Linux environment and launches the Power Cinema application.

If you are required to re-install Windows O/S or when you have purchased a new or upgraded HDD, you need to observe the following steps before installing Power Cinema.

1. Partitioning. Assuming you are starting with a fresh hard drive or the hard drive is removed of its previous partitions. You need to reserve 500MB of disc space for Power Cinema. You could either use a partition tool or as you install Windows XP, when Windows prompts you about creating a partition for Windows during the initial installation process (*Press C to create a new partition for Windows*), you should set aside 500MB of disc space. For example, if your hard drive has 30GB disk space, then you should create a partition of 29.5GB for Windows and leave 500MB aside for Power Cinema.



Note: Power Cinema needs to be on the 4th primary partition. Otherwise, the system cannot boot to Power Cinema when you press the P button.

please create a new one.

2-2 Insert the PCM4 Linux installation disc into the optical drive and reboot the system.

2-3 When system finished booting from the optical drive, you should see a warning message. Read it carefully.

2-4 In the step above, follow the on-screen instruction. When prompted, type "YES", and then press the "Enter" key. It will take about 2-3 minutes to install the software.

2-5 When installation is finish, please type "poweroff" and press the "Enter" key to shutdown system. Press the P button to start Power Cinema.



Note: If you made a mistake in the steps above, (for example, you didn't type "YES" in the 4th step), the system will exit to a Linux shell. If you still want to install PCM Linux, you can continue the installation by typing "install.sh" in the command prompt and you will return to step 2-3 as above.

page. The corresponding function opens, allowing you to enjoy the type of media you have selected.

Finding and Playing Content

Click or press **Enter** to open folders and to play or view media files. To go up a folder level, click the onscreen up arrow. To return to a previous screen within a mediafunction, click **Return**. Use the **Up**, **Down**, **Left**, and **Right** buttons to navigate within PowerCinema. To return to the Welcome page from within a media function, click the **Backspace** key on the keyboard.

Audio CD

Click a track to play it or click **Play All** to play all of the tracks displayed. Click **Stop** to stop music playback. To navigate in the list of tracks, click **Next** or **Prev**.

Note: When you exit this function, music playback stops.

DVD/VCD

Whenever you move the mouse during playback, player controls appear at the bottom of the screen. These player controls include the following: **Play** (plays the movie), **Stop** (stops movie playback), **Pause** (pauses movie playback), **Next** (jumps to the next movie chapter), **Prev** (jumps to the previous movie chapter), **Fast Forward** (fast forwards movie playback), **Rewind** (rewinds movie playback), **Main Menu** (goes to the disc's main menu), and **Quit** (returns to the Welcome page). These controls automatically disappear several seconds after the mouse stops moving. To facilitate navigation and media playback, use the following hotkeys while watching a DVD/VCD movie:

- Left arrow** Navigate left in the main menu
- Up arrow** Navigate up in the main menu
- Right arrow** Navigate right in the main menu
- Down arrow** Navigate down in the main menu
- F** Fast forward
- H** Audio
- L** Main menu
- Enter** Play

- Q** Mute
- 0-9** Enter numbers 0-9
- S** Stop
- A** Angle
- T** Step
- B** Scan backward
- U** Subtitles
- E** Step backward

Music Clips

Use this function to listen to music files in MP3 and WAV formats. Click **Device** to select a media source. You can select **CDROM** (for media on a CD), **USB Devices** (for media on a removable device), or **HDD** (for media in hard disk folders).

Click a music clip to play it or click **Play All** to play all of the clips displayed. Click **Stop** to stop music playback. To navigate in the list of clips, click **Next** or **Prev**.

Note: When you exit this function, music playback continues.

Photo

Use this function to view photo files in BMP, JPG, PNG, and TGA formats.

Click **Device** to select a media source. You can select **CDROM** (for media on a CD), **USB Devices** (for media on a removable device), or **HDD** (for media in hard disk folders).

Click a photo to view it. Click **Slideshow** to view a slideshow of the photos in the current directory. When the **Subfolders** option is selected, images in all of the subfolders contained in the selected directory are also displayed in the slideshow. When this option is not selected, the slideshow plays only the photos in the directory you have selected. Press the **Backspace** key on the keyboard to exit the slideshow.

Video Clips

Use this function to watch video files in AVI, M1V, M2V, MPG, and MPEG formats.

Click **Device** to select a media source. You can select **CDROM** (for media on a CD), **USB Devices** (for media on a removable device), or **HDD** (for media in hard disk folders).

playback), **Pause** (pauses movie playback), and **Quit** (returns to the Welcome page). These controls automatically disappear several seconds after the mouse stops moving.

Settings

There are settings in PowerCinema to allow you to fine-tune its performance to your machine and your personal preferences.

DVD SPDIF...: Select the **DVD AC3/SPDIF** option for multi-channel sound. Select the **DVD PCM/SPDIF** option for 2-channel sound.

Language: Select the language you want to use for display in PowerCinema, then return to the main menu in order for the selection to take effect.

USB Refresh

Click **USB Refresh** each time you attach a USB device to your computer in order to enable PowerCinema to read from the device. (The amount of time required to refresh depends on the device.)

Eject

Click **Eject** to open your computer's CD/DVD ROM tray.

Reboot

Click **Reboot** to restart your computer and enter the Windows partition.

Battery Status Indicator

A battery icon appears on the Welcome page, indicating the power source (battery or AC adapter) your computer is currently using.

When your computer is using battery power, the icon appears as such:  Approximate battery life is also displayed next to this icon.

When your computer is using the AC adapter, the icon appears as such: 