

KR16 Series

Push Button Six-Point Selector

INSTRUCTION MANUAL

Notice

Please ensure that this instruction manual is given to the final user of the instrument.

Preface

This instruction manual describes the care for operation and wiring to help those who will be involved in the wiring, installation, operation and routine maintenance of the KR16 series. Keep this manual at the work site during operation of the KR16 series. While using this instrument, you should always follow the guidance provided herein. For matters regarding safety, potential damage to equipment and/or facilities, additional instructions are indicated by the following headings.

⚠ CAUTION

Exercise extreme caution as indicated. This heading indicates hazardous conditions that could cause damage to equipment and/or facilities.

⚠ CAUTION

1. When you wire, tighten the terminal connections firmly.
2. Input voltage and voltage/current of a load should be within contacts rated range. Otherwise, product life may be shortened and/or malfunctions may result.
3. Remodeling the instrument or using it in an anomalous way is prohibited.
4. For safe and proper use of the instrument, observe the instructions described in this manual.

Note: For accidents or damage arising from failure to observe ⚠ Caution described above, we will take no responsibility nor provide compensation.

1. Specifications

- | | |
|---|---|
| <input type="checkbox"/> No. of switching points: 6
<input type="checkbox"/> No. of switching circuits: 2
<input type="checkbox"/> Switching operation method: Push button switching
<input type="checkbox"/> Applicable signal: D.C. voltage/current (R.T.D. is not applicable)

<input type="checkbox"/> Contact rating
Contact method: contact side
Voltage: 30V DC max.
Current: 100mA DC max.
Contact Resistance: 300mΩ max.
<input type="checkbox"/> Operating ambient temperature range: -10 ~ +50°C | <input type="checkbox"/> Operating ambient humidity range: 90%RH max. (no dew condensation)
<input type="checkbox"/> Material: PPO resin
<input type="checkbox"/> Color: Case: Munsell No. N-1 or compatible
Front Panel: Munsell No. N-1 or compatible
<input type="checkbox"/> External dimensions: H48 × W96 × D118 (panel depth: 100)mm
<input type="checkbox"/> Panel cutout: H45 × W92mm
<input type="checkbox"/> Mounting: Push-in Panel (one-touch mount)
<input type="checkbox"/> Panel thickness: 1.0 ~ 4.0mm
<input type="checkbox"/> Weight: Approx. 250g |
|---|---|

2. Code selection

Item	Code	Specifications
1. Series	KR16-	Push button six-point selector
2. Remark	0	Without
	9	With

3. Input selection

Six buttons are provided in a row. When no button is pressed, all input signals remain OFF.

To input, press the button of an appropriate number. The button is locked with a click in a recessed position in comparison to the other buttons and an input signal is activated.

Pressing a button while some other button is ON unlocks the latter to be turned OFF, and the newly pressed button is then turned ON.

When two or more buttons are pressed inadvertently at the same time and become locked, release them by pressing any of the remaining buttons. If not released, this may become a source of trouble.

4. Application Example

1. Selection of T.C. Switching

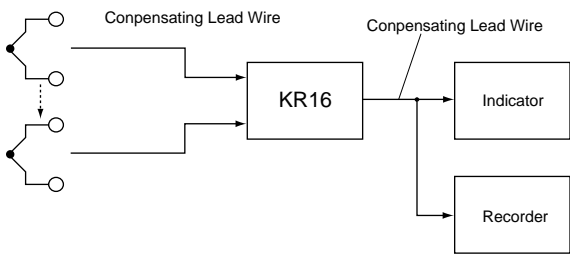

2. Selection of Voltage Switching

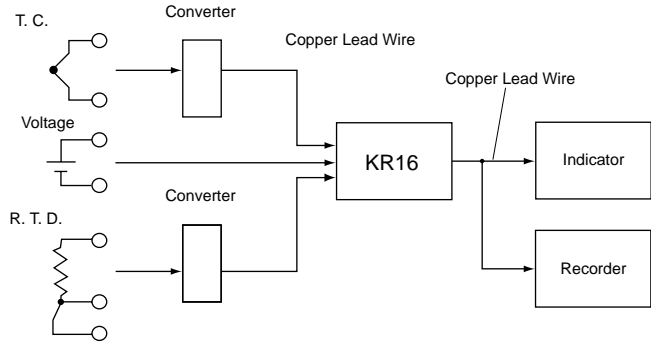

3. Selection of Analog Output (Voltage)

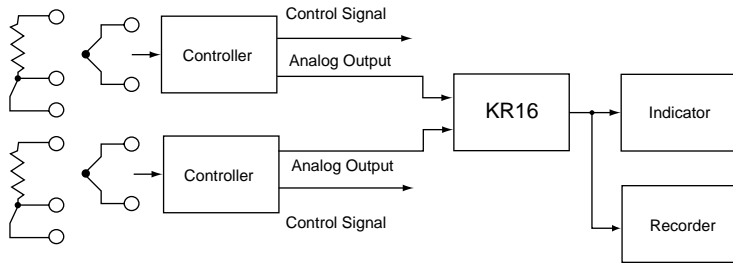

• Installation Example With SD16

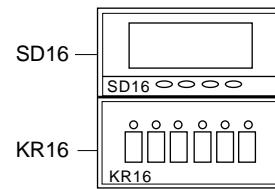

5. External Dimensions, Terminal Arrangement & Panel Cutout

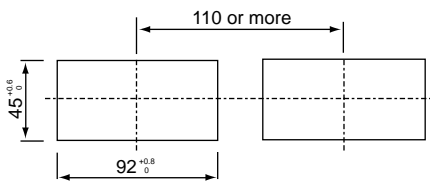
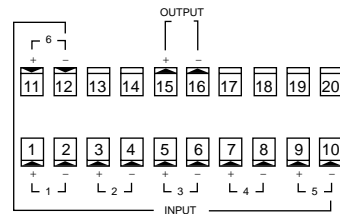
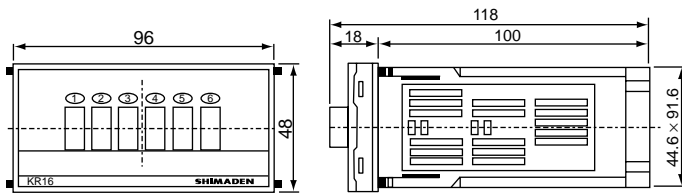

• In case installed with SD16

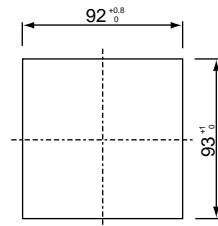

Unit: mm

The contents of this manual are subject to change without notice.

Temperature and Humidity Control Specialists
SHIMADEN CO., LTD.

Head Office: 2-30-10 Kitamachi, Nerima-Ku, Tokyo 179-0081 Japan
 Phone: +81-3-3931-7891 Fax: +81-3-3931-3089
 E-MAIL: exp-dept@shimaden.co.jp URL: <http://www.shimaden.co.jp>

PRINTED IN JAPAN