

OPERATION AND PARTS MANUAL



Mikasa **SERIES**
MODEL MT-84F
TAMPING RAMMER
(ROBIN GASOLINE ENGINE)

Revision #2 (06/30/05)

To find the latest revision of this
publication, visit our website at:
www.multiquip.com



THIS MANUAL MUST ACCOMPANY THE EQUIPMENT AT ALL TIMES.



WARNING



CALIFORNIA — Proposition 65 Warning

Engine exhaust and some of its constituents are known to the State of California to cause cancer, birth defects and other reproductive harm.

Multiquip Tamping Rammer MT-84F

Proposition 65 Warning	2
Here's How To Get Help	4
Table Of Contents	5
Parts Ordering Procedures	5
Safety Message Alert Symbols	6-7
Rules For safe Operation	8-9
Operation and Safety Decals	10-11
General Information	12
Specifications	13
Controls and Components	14
Basic Engine	15
Operation	16-18
Maintenance	19
Troubleshooting Guide	20-21
Explanation Of Codes In Remarks Column	23
Suggested Spare Parts	23
Nameplate and Decals	24-25
Crankcase and Engine Assembly	26-29
Guide Cylinder and Foot Assembly	30-31
Tank and Handle Assembly	32-33

ROBIN EH-12-2D46051 ENGINE

Crankcase and Cylinder Assembly	34-35
Crankshaft and Piston Assembly	36-37
Muffler, Air Cleaner, Camshaft, & Carb. Assy.	38-39
Governor Assembly	40-41
Recoil Starter and Blower Assembly	42-43
Magneto Assembly	44-45
Carburetor Assembly	46-47
Terms and Conditions of Sale	48

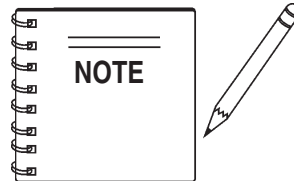

*Specification and part number
are subject to change without
notice.*

MT-84F — PARTS ORDERING PROCEDURES

When ordering parts, please supply the following information:

- Dealer account number
- Dealer name and address
- Shipping address (if different than billing address)
- Return fax number
- Applicable model number
- Quantity, part number and description of each part
- Specify preferred method of shipment:
 - ✓ FedEx or UPS Ground
 - ✓ FedEx or UPS Second Day or Third Day
 - ✓ FedEx or UPS Next Day
 - ✓ Federal Express Priority One
 - ✓ DHL
 - ✓ Truck

Note: Unless otherwise indicated by customer, all orders are treated as "Standard Orders", and will ship within 24 hours. We will make every effort to ship "Air Shipments" the same day that the order is received, if prior to 2PM west coast time. "Stock Orders" must be so noted on fax or web forms.



Here's how to get help...

Please have the model and serial number on hand when calling.

MULTIQUIP CORPORATE OFFICE

18910 Wilmington Ave. 800-421-1244
 Carson, CA 90746 FAX: 310-537-3927
 Email: mq@multiquip.com
 Internet: www.multiquip.com

PARTS DEPARTMENT

800-427-1244 FAX: 800-672-7877
 310-537-3700 FAX: 310-637-3284

MAYCO PARTS

800-306-2926 FAX: 800-672-7877
 310-537-3700 FAX: 310-637-3284

SERVICE DEPARTMENT

800-421-1244 FAX: 310-537-4259
 310-537-3700

TECHNICAL ASSISTANCE

800-478-1244 FAX: 310-631-5032

WARRANTY DEPARTMENT

800-421-1244, EXT. 279 FAX: 310-537-1173
 310-537-3700, EXT. 279

Place Your Parts Order Via Web or Fax For Even More Savings!

(Domestic USA Dealers Only)

Extra Discounts!

All parts orders which include complete part numbers and are received by our automated web parts order system, or by fax qualify for the following extra discounts:

Ordered via	Standard orders	Stock orders (\$750 list and above)
Fax	3%	10%
Web	5%	10%

Special freight allowances when you order 10 or more line items via Web or Fax! **

FedEx Ground Service **at no charge for freight**

No other allowances on freight shipped by any other carrier.

****Common nuts, bolts and washers (all items under \$1.00 list price) do not count towards the 10+ line items.**

NOTE: DISCOUNTS ARE SUBJECT TO CHANGE



MULTIQUIP INC.
 18910 WILMINGTON AVENUE
 POST OFFICE BOX 6254
 CARSON, CALIFORNIA 90749
 310-537-3700 • 800-421-1244
 FAX: 310-537-3927
 E-MAIL: mq@multiquip.com
 INTERNET: www.multiquip.com

Direct TOLL-FREE access to our Parts Department:

Toll-free nationwide — 800-427-1244

Toll-free FAX — 800-6-PARTS-7 (800/672-7877)

MT-84F — SAFETY MESSAGE ALERT SYMBOLS

FOR YOUR SAFETY AND THE SAFETY OF OTHERS!

Safety precautions should be followed at all times when operating this equipment. Failure to read and understand the Safety Messages and Operating Instructions could result in injury to yourself and others.

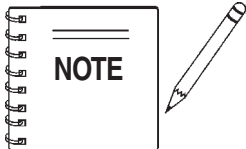

This Owner's Manual has been developed to provide complete instructions for the safe and efficient operation of the **MQ Mikasa, Model MT-84F Tamping Rammer**. Refer to the engine manufacturers instructions for data relative to its safe operation.

Before using this rammer, ensure that the operating individual has read and understands all instructions in this manual.

SAFETY MESSAGE ALERT SYMBOLS

The three (3) Safety Messages shown below will inform you about potential hazards that could injure you or others. The Safety Messages specifically address the level of exposure to the operator, and are preceded by one of three words: **DANGER**,

DANGER

You **WILL** be **KILLED** or **SERIOUSLY INJURED** if you **DO NOT** follow these directions.

WARNING

You **CAN** be **KILLED** or **SERIOUSLY INJURED** if you **DO NOT** follow these directions.

CAUTION

You **CAN** be **INJURED** if you **DO NOT** follow these directions.

HAZARD SYMBOLS

Potential hazards associated with the operation of a **MT-84F Tamping Rammer** will be referenced with Hazard Symbols which appear throughout this manual, and will be referenced in conjunction with Safety Message Alert Symbols.

WARNING Lethal Exhaust Gas Hazards

Engine exhaust gases contain poisonous carbon monoxide. This gas is colorless and odorless, and can cause death if inhaled. **NEVER** operate this equipment in a confined area or enclosed structure that does not provide ample free flow air.



WARNING Explosive Fuel Hazards

Gasoline is extremely flammable, and its vapors can cause an explosion if ignited. **DO NOT** start the engine near spilled fuel or combustible fluids.



DO NOT fill the fuel tank while the engine is running or hot. **DO NOT** overfill tank, since spilled fuel could ignite if it comes into contact with hot engine parts or sparks from the ignition system. Store fuel in approved containers, in well-ventilated areas and away from sparks and flames.

WARNING Burn Hazards

Engine components can generate extreme heat. To prevent burns, **DO NOT** touch these areas while the engine is running or immediately after operations. Never operate the engine with heat shields or heat guards removed.



WARNING Respiratory Hazards

ALWAYS wear approved **respiratory** protection when required.



MT-84F — SAFETY MESSAGE ALERT SYMBOLS

CAUTION

Rotating Parts Hazards

NEVER operate equipment with covers, or guards removed. Keep fingers, hands, hair and clothing away from all moving parts to prevent injury.



CAUTION

Equipment Damage Hazards

Other important messages are provided throughout this manual to help prevent damage to your light tower, other property, or the surrounding environment.

CAUTION

Accidental Starting Hazards

ALWAYS place the ON/OFF switch in the **OFF** position when the rammer is not in use.



CAUTION

Eye and Hearing Hazards

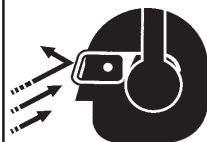

ALWAYS wear approved eye and hearing protection.

WARNING



To avoid injury, you **MUST** read and understand operator's manual before using this machine.

This machine to be operated by qualified personnel only. Ask for training as needed.



DANGER

Refueling Hazard

NEVER refuel rammer when placed in truck bed with plastic liner. The possibility exists of explosion due to static electricity. When adding fuel, remove rammer from truck bed and place on ground.

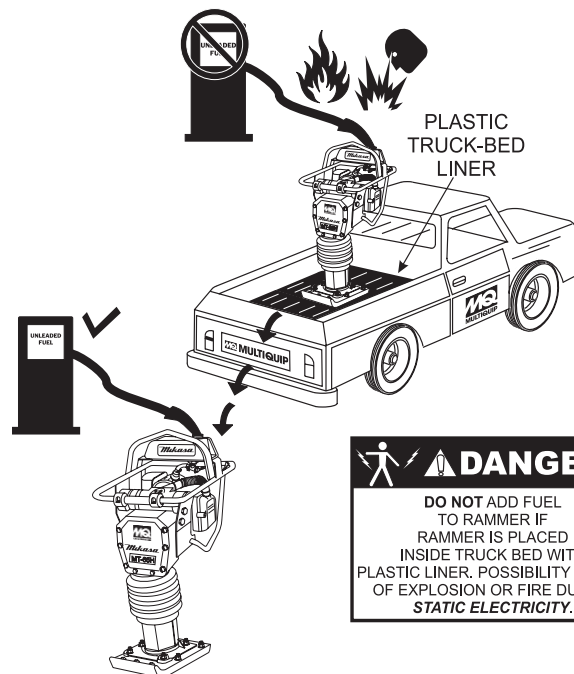

 **DANGER**

DO NOT ADD FUEL TO RAMMER IF RAMMER IS PLACED INSIDE TRUCK BED WITH PLASTIC LINER. POSSIBILITY EXISTS OF EXPLOSION OR FIRE DUE TO **STATIC ELECTRICITY**.

MT-84F — RULES FOR SAFE OPERATION

DANGER

Read this manual!

Failure to follow instructions in this manual may lead to serious injury or even death! This equipment is to be operated by trained and qualified personnel only! This equipment is for industrial use only.

The following safety guidelines should always be used when operating the MT-84F Tamping Rammer:

GENERAL SAFETY

■ **DO NOT** operate or service this equipment before reading this entire manual.



■ This equipment should not be operated by persons under 18 years of age.

■ **NEVER** operate this equipment without proper protective clothing, shatterproof glasses, steel-toed boots and other protective devices required by the job.



■ **NEVER** operate this equipment when not feeling well due to fatigue, illness or taking medicine.



■ **NEVER** operate this equipment under the influence of **drugs** or **alcohol**.



■ **ALWAYS** wear proper respiratory (mask), hearing and eye protection equipment when operating the rammer.



■ Whenever necessary, replace nameplate, operation and safety decals when they become difficult read.

■ Manufacturer does not assume responsibility for any accident due to equipment modifications.

■ **NEVER** use accessories or attachments, which are not recommended by Multiquip for this equipment. Damage to the equipment and/or injury to user may result.

■ **NEVER** touch the hot exhaust manifold, muffler or cylinder. Allow these parts to cool before servicing engine or rammer.



■ **High Temperatures** – Allow the engine to cool before adding fuel or performing service and maintenance functions. Contact with **hot!** components can cause serious burns.

■ The engine section of this rammer requires an adequate free flow of cooling air. **NEVER** operate the rammer in any enclosed or narrow area where free flow of the air is restricted. If the air flow is restricted it will cause serious damage to the rammer or engine and may cause injury to people. Remember the rammer's engine gives off **DEADLY** carbon monoxide gas.

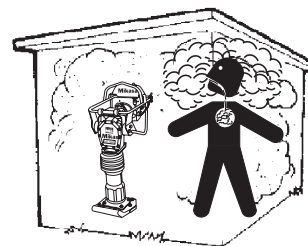

■ **ALWAYS** refuel in a well-ventilated area, away from sparks and open flames.

■ **ALWAYS** use extreme caution when working with **flammable** liquids. When refueling, **stop the engine** and allow it to cool.

■ **NEVER** operate the rammer in an explosive atmosphere or near combustible materials. An explosion or fire could result causing severe **bodily harm or even death**.



■ **DO NOT smoke** around or near the machine. Fire or explosion could result from fuel vapors, or if fuel is spilled on a hot engine.



■ Topping-off to filler port is dangerous, as it tends to spill fuel.

■ Stop the engine when leaving the rammer unattended.

■ Maintain this equipment in a safe operating condition at all times.

MT-84F — RULES FOR SAFE OPERATION

- **ALWAYS** stop the engine before servicing, adding fuel and oil.
- **NEVER** run engine without air filter. Severe engine may occur.
- **ALWAYS** service air cleaner frequently to prevent carburetor malfunction.
- **ALWAYS** check the machine for loosened threads or bolts before starting.
- **ALWAYS** be sure the operator is familiar with proper safety precautions and operations techniques before using rammer.
- **ALWAYS** store equipment properly when it is not being used. Equipment should be stored in a clean, dry location out of the reach of children.
- **DO NOT** operate this equipment unless all guards and safety devices are attached and in place.
- **CAUTION** must be exercised while servicing this equipment. Rotating and moving parts can cause injury if contacted.
- Keep all **inexperienced** and **unauthorized** people away from the equipment at all times.
- Unauthorized equipment modifications will void all warranties.
- **NEVER** pour or spray water over the engine.
- Test the engine **ON/OFF** switch before operating. The purpose of this switch is to shut down the engine of the rammer.
- Refer to the **ROBIN Engine Owner's Manual** for engine technical questions or information recommended by Multiquip for this equipment.

TRANSPORTING

- **ALWAYS** shutdown engine before transporting.
- Tighten fuel tank cap securely and close fuel cock to prevent fuel from spilling.
- Drain fuel when transporting rammer over long distances or bad roads.
- When placing the rammer inside a truck-bed for transport, always tie-down the rammer

MAINTENANCE

- **NEVER** lubricate components or attempt service on a running rammer.
- **ALWAYS** allow the rammer a proper amount of time to cool before servicing.
- Keep the rammer in proper running condition.
- Fix damage to the rammer immediately and always replace broken parts.
- Dispose of hazardous waste properly. Examples of potentially hazardous waste are used motor oil, fuel and fuel filters.
- **DO NOT** use food or plastic containers to dispose of hazardous waste.

EMERGENCIES

- **ALWAYS** know the location of the nearest **fire extinguisher** and **first aid kit**.



- In emergencies **always** know the location of the nearest phone or **keep a phone on the job site**. Also know the phone numbers of the nearest **ambulance**, **doctor** and **fire department**. This information will be invaluable in the case of an emergency.



MT-84F — OPERATION AND SAFETY DECALS

Machine Safety Decals

The MQ Mikasa MT-84F tamping rammer is equipped with a number of safety decals. These decals are provided for operator safety and maintenance information. Figures 1 and 1A below and preceding page illustrates these decals as they appear on the machine. Should any of these decals become unreadable, replacements can be obtained from your dealer.



P/N 0732004450



P/N 920108310



P/N 920210170

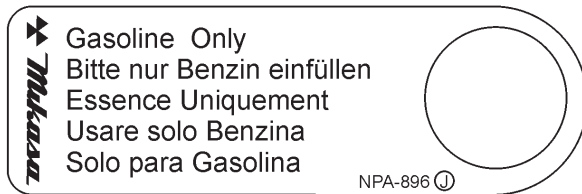

P/N 920208960



P/N 920210180

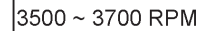

P/N 920210150

First remove the element from the pre-cleaner located at the top of the machine. Clean the element with solvent. Apply SAE-30 motor oil as follows: top element (yellow) with 2 to 5 cc and the bottom element (gray) with 13 to 15 cc. Be sure to squeeze out excess oil before reinstalling.

NPA-437 J

P/N 920204370

- READ OWNER'S SERVICE MANUAL BEFORE OPERATING OR SERVICING THIS MACHINE.
- ALWAYS KEEP UNAUTHORIZED, INEXPERIENCED, UNTRAINED PEOPLE AWAY FROM THIS MACHINE.
- MAKE SURE ALL SAFETY DEVICES ARE OPERATIONAL BEFORE THIS MACHINE IS STARTED. MAKE SURE ENGINE IS TURNED OFF AND SPARK PLUG WIRE DISCONNECTED BEFORE SERVICING THE MACHINE OR COMING IN CONTACT WITH ANY MOVING PART. IF EQUIPMENT IS POWERED BY AN ELECTRIC MOTOR DISCONNECT ELECTRICAL PLUG.
- NEVER LEAVE MACHINE UNATTENDED WHEN OPERATING. ALWAYS STOP ENGINE AND ALLOW ENGINE TO COOL BEFORE ADDING FUEL OR OIL.

NPA-329 J

P/N 920203290

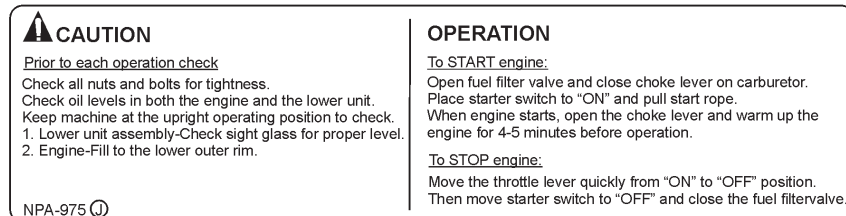

P/N 920209750

Figure 1. Rammer Operation and Safety Decals

MT-84F — OPERATION AND SAFETY DECALS

**SECONDARY AIRFILTER
SERVICE MONTHLY**

NPA1016

P/N 920210160

To start, switch must be
in the "ON" position

NPA 293

P/N 920202930

When you stop
the engine, be
sure to close
the fuel cock.

NPA-399

P/N 920203990

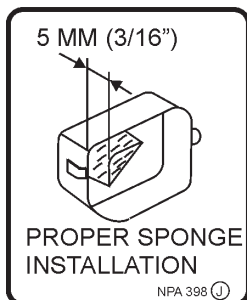

P/N 920203980



P/N 920100240



P/N 920203330

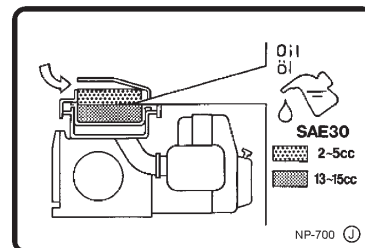

P/N 920107000

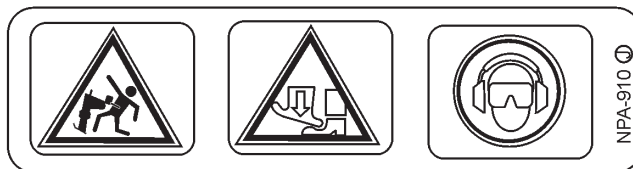

P/N 920209100

CAUTION
ATTENZIONE
ATENÇÃO
PRECAUCION

* Read operator's manual carefully before use.
* Libre le manual attentivement avant utilisation.
* Bitte lesen Sie vor inbetriebnahme der Maschine de Bedienungsanleitung sorgfältig durch.
* Prima dell' uso leggere attentamente il manuale.
* Lee com atenção o manual de instruções antes de usar.
* Leer detenidamente el manual de instrucciones antes de usar la maquina.

NPA-769

P/N 920207690

WARNING

- ★ READ ENGINE STARTING AND OPERATING GUIDE CAREFULLY BEFORE STARTING ENGINE.
- ☐ SHUT OFF ENGINE BEFORE REFUELING. THOROUGHLY WIPE SPILLED FUEL BEFORE STARTING.
- ☐ CHECK FOR LEAKAGE FROM HOSES AND FITTINGS.
- ☐ KEEP FLAMMABLES AWAY FROM ENGINE.
- ☐ SHUT OFF FUEL VALVE WHEN ENGINE IS NOT IN USE.
- ☐ OPERATE ENGINE IN A WELL VENTILATED AREA. DO NOT OPERATE IN A CLOSED ROOM.
- ☐ DO NOT TOUCH MUFFLER OR ANY AREA NEAR EXHAUST DURING OPERATION.

P/N TBD

Mikasa

Serial No.

Model No.

MULTIQUIP

CONTACT
MQ PARTS DEPT.

Figure 1A. Rammer Operation and Safety Decals

Definition of Tamping Rammer

The Mikasa MT-84F tamping rammer is a powerful compacting tool capable of applying a tremendous force in consecutive impacts to a soil surface. Its applications include soil compacting for road, embankments and reservoirs as well as backfilling for gas pipelines, water pipelines and cable installation work.

The impact force of the MT-84F levels and uniformly compacts voids between soil particles to increase dry density.

Circular motion is converted to create impact force. The MT-84F tamping rammer develops a powerful compacting force at the foot of the rammer. To maintain optimum performance, proper operation and service are essential.

Construction of Tamping Rammer

The Mikasa MT-84F is equipped with an air cooled, two cycle gasoline engine. Transmission of the power takes place by increasing the engine speed to engage the centrifugal clutch.

Rammer Gearbox and Spring Cylinder

The Mikasa MT-84F uses an oil bath lubrication system. Always check the oil level through the oil level sight glass at the rear of the tamper foot.

Controls

Before starting the MT-84F Tamping Rammer, identify and understand the function of the controls. See Figure 2.

Table 1. MT-84F Rammer Specifications

MODEL	MT-84F
Overall Height	40.35 in. (1,025 mm)
Overall Width	16.33 in (415 mm)
Over Length	28.07 in (713 mm)
Shoe Size L x W	11.22 x 13.38 in. (285 x 340 mm)
Blows/minute	660-700
Impact Force	3,100 lbs./blow (1,400-1,600 kg/blow)
Jumping Stroke	1.96~3.14 in. (50~80 mm)
Clutch	Automatic Centrifugal
Lubrication System	Oil Bath-10W-30 Motor Oil
Fuel Capacity	.66 Gallons (2.5 Liters)
Operating Weight (W/Fuel)	185 lbs. (84 kg)

Table 2. EH12-2D Engine Specifications

MODEL	ROBIN EH12-2D46051 ENGINE
Type	Air-Cooled 4 Stroke Gasoline Engine
Piston Displacement	7.38 cu.in. (121 cm ³)
Max. Output	4.0 HP
Max. Governed Speed, No Load	4,000 RPM
Cooling System	Air-Cooled
Oil Capacity	0.64 qts. (600 cc.)
Fuel	Unleaded gasoline
Starting System	Recoil Starter
Dry Weight	33.1 lbs. (15.0 kg.)
Dimensions	11.93 x 13.90 x 14.41 (303 x 353 x 366 mm)

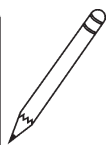
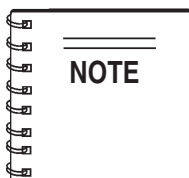

Specifications are general and are subject to change without notice. If exact measurements are required, equipment should be weighed and measured.

MT-84F — CONTROLS AND COMPONENTS

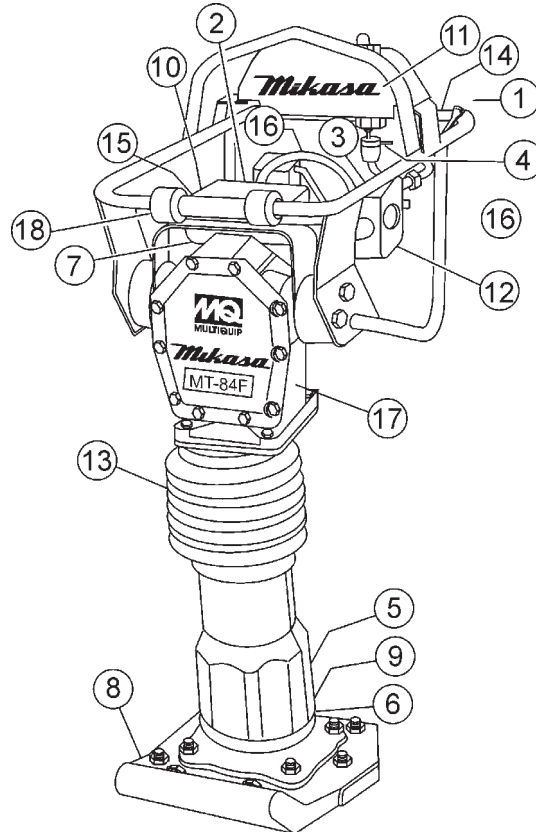

Figure 2. MT-84F Rammer

Figure 2 shows the location of the controls and components for the MT-84F Tamping Rammer. The functions of each control is described below:

1. **Throttle Lever** – Controls engine speed and the tamping action of the rammer.
2. **Engine Stop Switch** – Controls the starting and stopping of the engine. Switch must be in the "ON" position when starting the engine.
3. **Choke Lever** – Used when starting the engine. Normally used in cold weather conditions. In cold weather turn the choke lever to the fully closed position, in warm weather set choke lever half way or completely open.
4. **Fuel Shut-Off Valve** – Supplies fuel from the fuel tank to the engine. To begin fuel flow move the fuel shut-off valve downward.
5. **Oil Bath Fill Plug** – Open this plug to add oil to the oil bath reservoir.
6. **Drain Valve** – Open this valve to remove oil from the bellows.
7. **Pre-Cleaner** – Pre-cleans (first stage) dirt and other debris from entering the engine.
8. **Foot** – Laminated wood with tempered steel plate for superior shock absorption.
9. **Oil Level Sight Glass** – Indicates the level of oil in the oil bath reservoir.
10. **Recoil Starting Handle** – Used when starting the engine. Pull starter handle sharply and quickly, then return starter handle to starter case before releasing.
11. **Fuel Tank/Cap** – Poly fuel tank to avoid rust and corrosion, remove this cap to add gasoline.
12. **Engine Air Cleaner** – Prevents dirt (second stage) and other debris from entering the engine.
13. **Bellows** – Reservoir for oil bath.
14. **Handle** – To operate rammer **GRIP** handle assembly firmly on both sides.
15. **Muffler** – Used to reduce noise and emissions.
16. **Spark Plug** – Provides spark to the ignition system, replace with engine manufactures recommended type spark plug.
17. **Nameplate** – Displays information regarding the rammer.

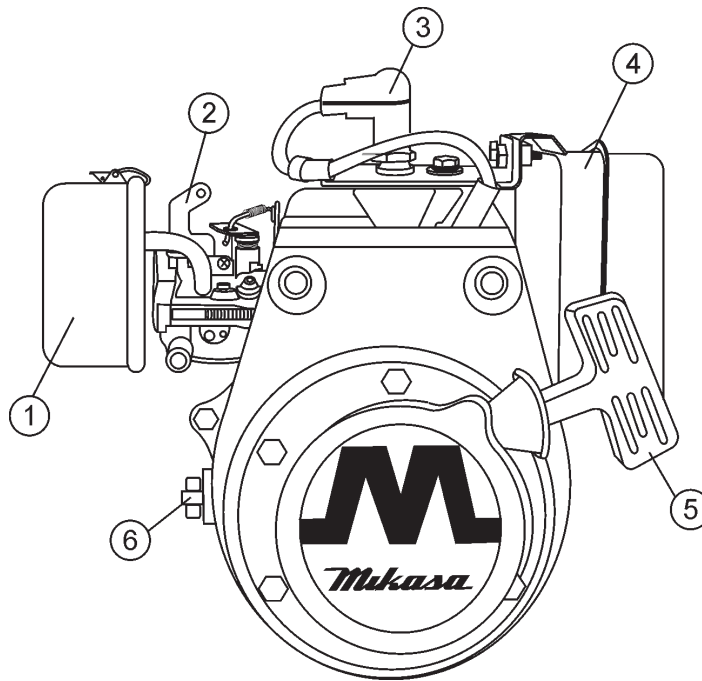

Figure 3. Robin EH-12-2D Engine Controls and Components

INITIAL SERVICING

The engine (Figure 3) must be checked for proper lubrication and filled with fuel prior to operation. Refer to the manufacturers Engine manual for instructions & details of operation and servicing.

1. **Secondary Air Cleaner** – Prevents dirt and other debris from entering the fuel system. Remove wing-nut on top of air filter cannister to gain access to filter element.
2. **Choke Lever** – Used when starting the engine. Normally used in cold weather conditions. In cold weather turn the choke lever to the fully closed position, in warm weather set choke lever half way or completely open.
3. **Spark Plug** – Provides spark to the ignition system. Set spark plug gap to 0.6 - 0.7 mm (0.024 - 0.028 inch). Clean spark plug once a week.
4. **Muffler** – Used to reduce noise and emissions.

5. **Recoil Starter (pull rope)** – Manual-starting method. Pull the starter grip until resistance is felt, then pull briskly and smoothly.
6. **Engine ON/OFF Switch** – Controls the starting and stopping of the engine. Switch must be in the "ON" position when starting the engine.

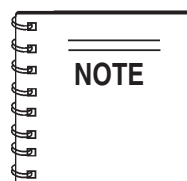

Operating the engine without an air filter, with a damaged air filter, or a filter in need of replacement will allow dirt to enter the engine, causing rapid engine wear.



WARNING

Engine components can generate extreme heat. To prevent burns, **DO NOT** touch these areas while the engine is running or immediately after operating. **NEVER** operate the engine with the muffler removed.

MT-84F — OPERATION

This section is intended to assist the operator with the initial start-up of the MT-84F Tamping Rammer. It extremely important that this section be read carefully before attempting to operate the rammer.

DO NOT use your rammer until this section is thoroughly understood.

CAUTION

Failure to understand the operation of the MT-84F Tamping Rammer could result in severe damage to the trowel or personal injury.

Rammer Gearbox and Spring Cylinder Oil Bath

This unit uses an oil bath lubrication system. Perform the following:

1. Check the oil level through the oil level sight glass (Figure 4) at the rear of the tamper foot.

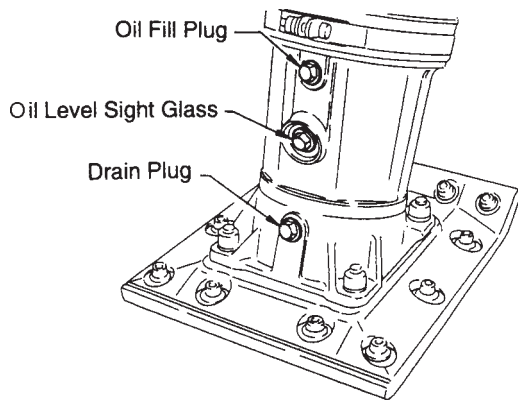
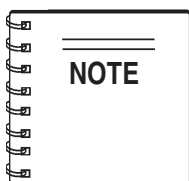

Figure 4. Foot Housing Sight Glass

2. If oil is not visible, add 10W-30 motor oil into the oil fill plug opening (Figure 2). The bath contains approximately 1.7 pints (800 cc.)



NOTE

The oil bath level should be kept at the half way point of the sight glass.

Fuel Check

1. Check the fuel level in the fuel tank. If the fuel level is low, fill the fuel tank (Figure 5) with clean unleaded gasoline.

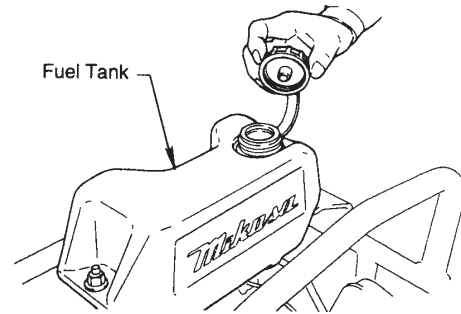

Figure 5. Fuel Tank

Engine Oil Check

1. To check the engine oil level, place the rammer on secure level ground with the engine stopped.
2. Remove the filler dipstick from the engine oil filler hole (Figure 6) and wipe it clean.

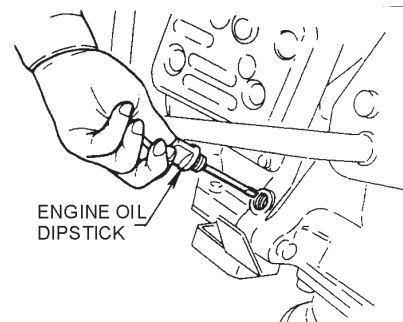

Figure 6. Engine Oil Dipstick

3. Insert and remove the dipstick without screwing it into the filler neck. Check the oil level shown on the dipstick.
4. If the engine oil level is low, fill to the edge of the oil filler hole with the recommended oil type (Table 3). See Table 2 for the oil capacity of your type engine.

Table 3 Motor Oil Grade

Season or Temperature	Grade of motor oil (higher than MS class)
Spring, Summer or Autumn +120° F to +15° F	SAE 30
Winter +40° F to +15° F	SAE 30
Below +15° F	SAE 10W-30

Inspection

1. Check all nuts, bolts fasteners for tightness. Retighten as necessary.
2. Clean any dirt from the recoil starter and foot pedestal. Wipe the entire unit clean before operating.
3. Replace any missing or damaged Safety Operation decals.
4. Adjust height of handle. Adjust handle by loosening nuts and moving handle to suit operation. Retighten nuts.

Initial Start-up

When starting the MT-84F Tamping Rammer perform the following:

1. Open the fuel shut-off valve by moving the **fuel cock** lever to the **open** position (Figure 7).

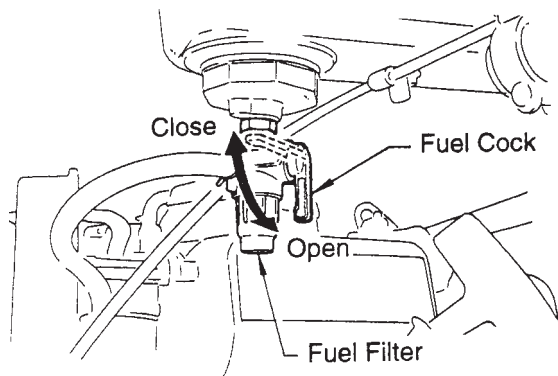

Figure 7. Fuel Cock

2. Set the engine ON/OFF switch (Figure 8) to the "ON" position (START).

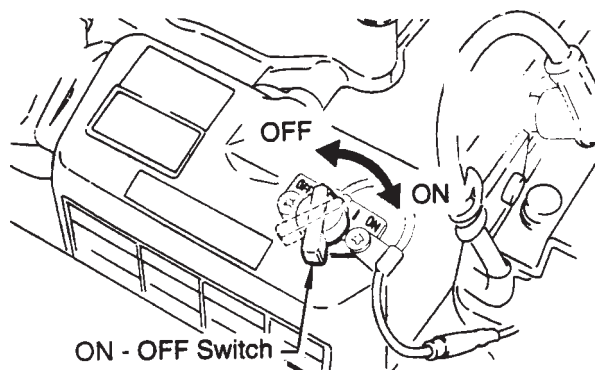

Figure 8. On/Off Switch

3. Close the choke lever (Figure 9) and move the throttle lever to the "Full Open" position. Turning the choke lever 90 degrees clockwise closes the choke. In cold weather, start the unit with choke fully closed. In warm weather or when the engine is warm, the unit can be started with choke halfway or completely open.

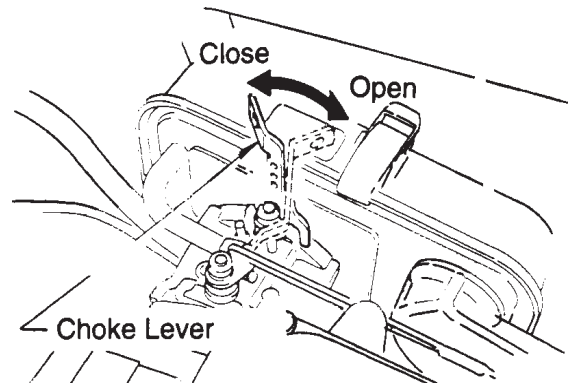

Figure 9. Choke Lever

4. Grip the recoil starter (Figure 10) handle and pull it until you feel a slight resistance. Then pull sharply and quickly. Return the recoil starter handle to the starter case before releasing.

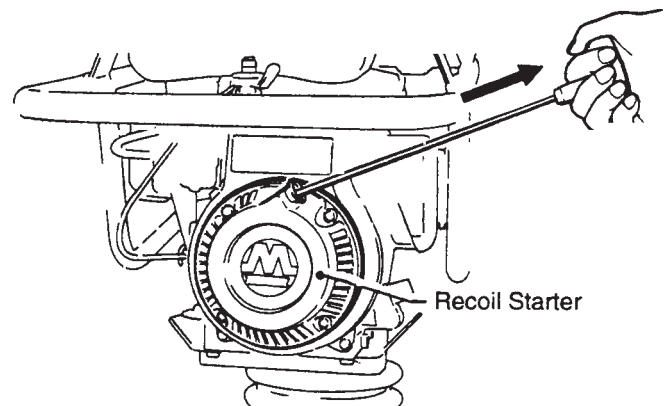

Figure 8. Recoil Starter

5. If engine fails to start, move the choke lever (Figure 9) to the half open position to avoid flooding.
6. Repeat steps 1 thru 4.
7. If the engine does not start after repeated attempts, check the spark plug for excess fuel. Clean and replace the spark plug as needed.

Operation

1. To start the rammer tamping action, move the throttle lever (Figure 11) quickly from **IDLE** (close) to the **FULL OPEN** position. **DO NOT** move the throttle lever slowly as this may cause damage to the clutch or spring.

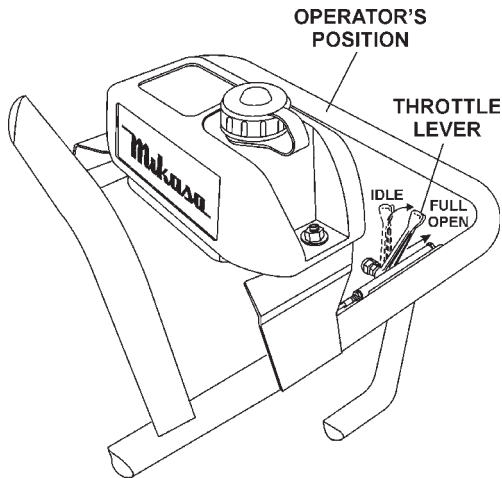

Figure 11. Throttle Lever (Full Open)

CAUTION

Make sure that the throttle lever is moved to the **FULL OPEN** position. Operating the rammer at less than full speeds can result in damage to the clutch springs or foot

2. The MT-84F tamping rammer is designed to run at 4,000 rpm. At optimum rpm the foot hits at the rate of 660~700 impacts per minute. Increasing throttle speed past factory set rpm does not increase impacts and may damage unit. The MT-84F is designed to advance while tamping. For faster advance, pull back slightly on the handle so that rear of foot contacts soil first.

3. To stop the tamping action, move throttle lever quickly from the **FULL OPEN** to **IDLE** position.

Stopping The Engine

Normal Shutdown

1. Move throttle lever quickly from the **FULL OPEN** to **IDLE** position (Figure 12) and run the engine for three minutes at low speed. After the engine **cools**, turn the engine start/stop switch to the "**STOP**" position (Figure 8) until engine comes to a complete stop.

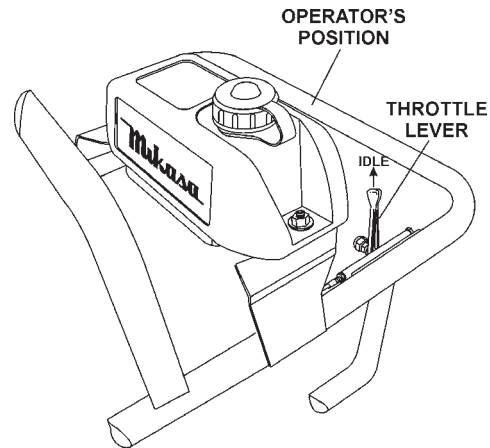

Figure 12. Throttle Lever (Idle)

2. Close the fuel shut-off valve by moving the fuel cock lever to the **CLOSED** position. See Figure 5.

Emergency Showdown

1. Move the throttle lever quickly to the **IDLE** position, and turn the engine start/stop switch to the **STOP** position.

Maintenance

Perform the scheduled maintenance procedures as indicated:

DAILY

- Thoroughly remove dirt and oil from the engine and control area. Clean or replace the air cleaner elements as necessary. Check and retighten all fasteners as necessary. Check the spring box and bellows for oil leaks. Repair or replace as needed.

WEEKLY

- Remove the fuel filter cap and clean the inside of the fuel tank.
- Remove or clean the filter at the bottom of the tank.
- Remove and clean the spark plug, then adjust the spark gap to 0.02~0.03 inch (0.6~0.7 mm). This unit has electronic ignition, which requires no adjustments.
- Clean air cleaner cover.

200 - 300 HOURS (Pre-Cleaner)

- Remove the element from the pre-cleaner (Figure 13) at the top of the crankcase (body side) and clean it with cleaning oil (kerosene).

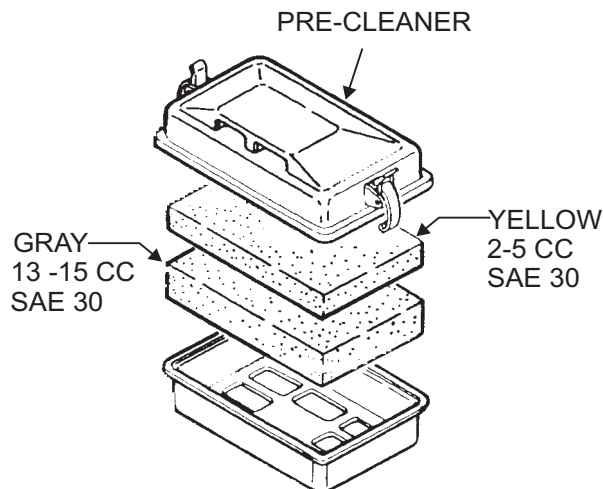

Figure 13. Pre-Cleaner

- Lubricate the top element (yellow) with 2~5 cc of engine oil SAE-30.
- Lubricate bottom element (gray) with 13 ~15 cc of engine oil SAE-30 and completely squeeze out the excess oil from the element before installing.

- The air cleaner (Figure 14) on the engine side will hardly be contaminated, if it is, however after cleaning the element with kerosene, dip it in mixed oil consisting of 3 parts of gasoline and 1 part of engine oil. Then tightly squeeze outer primary element (sponge) and shake off well the inner secondary element before installing them.

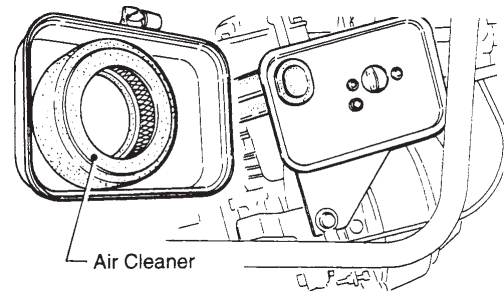

Figure 14. Engine Air Cleaner

200 - 300 HOURS (Oil Bath)

- Drain oil reservoir on foot housing (Figure 15). Refill with approximately 1.7 pt. (800 cc) of 10W-30 motor oil. Oil should be midway in sight glass. Break in oil should be changed after first 50 hours.

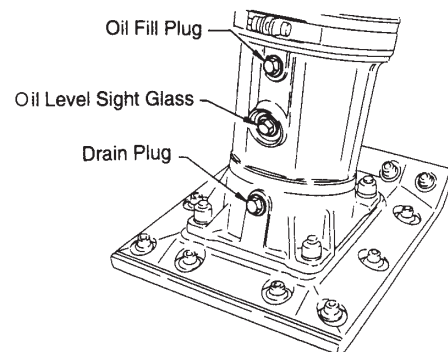

Figure 15. Foot Housing Drain Plug

Yearly

- Check the fuel line and the oil line regularly for damage and to ensure that there are no leaks.
- Replace the oil and fuel lines every two years to maintain the performance and flexibility lines.

Long Term Storage

- Drain fuel from fuel tank, fuel line and carburetor.
- Remove spark plug and pour a few drops of motor oil into cylinder. Crank engine 3 to 4 times so that oil reaches all internal parts.
- Clean exterior with a cloth soaked in clean oil.
- Store unit covered with plastic sheet in moisture free and dust free location out of direct sunlight

MT-84F — TROUBLESHOOTING GUIDE

TABLE 4. ENGINE TROUBLESHOOTING

SYMPTOM	POSSIBLE PROBLEM	SOLUTION
Difficult to start		
Fuel is available but spark plug will not ignite. (Power available at high tension cable).	Ignition plug being bridge?	Check ignition system.
	Carbon deposit at ignition?	Clean or replace ignition.
	Short circuit due to defective insulators?	Replace insulators.
	Improper spark gap?	Set spark plug gap to the correct gap.
Fuel is available but spark plug will not ignite. (Power NOT available at high tension cable).	Short circuit at stop switch?	Check stop switch circuit. Replace stop switch if defective.
	Ignition coil defective?	Replace ignition coil.
Fuel is available and spark plug ignites (compression normal).	Muffler clogged with carbon deposits?	Clean or replace muffler.
	Fuel in use inadequate (water, dust)?	Flush fuel sytem and replace with fresh fuel.
	Air Cleaner clogged?	Clean or replace air cleaner.
Fuel is available and spark plug ignites (compression low).	Defective cylinder head gasket?	Tighten cylinder head bolts or replace head gasket.
	Cylinder worn?	Replace cylinder.
	Spark plug loose?	Tighen spark plug.
Operation not satisfactory		
Not enough power available (compression normal, no miss-firing).	Air cleaner clogged?	
	Air in fuel line?	Bleed (remove air) from fuel line.
	Fuel level in carbureator float chamber improper?	Adjust carbureator float
	Carbon deposits in cylinder?	Clean or replace cylinder
Not enough power available (compression normal, miss-firing).	Ignition coil defective?	Flush fuel sytem and replace with fresh fuel.
	Ignition plug often shorts?	Replace ignition wires, clean ignition.
	Fuel in use inadequate (water, dust)?	Flush fuel sytem and replace with fresh fuel.
Engine overheats.	Excessive carbon depostion in combustion chamber?	Clean or replace crankcase.
	Exhaust or muffler clogged with carbon.	Clean or replace muffler.
	Spark plug heat value incorrect?	Replace spark plug with correct type spark plug.

MT-84F — TROUBLESHOOTING GUIDE

TABLE 4. ENGINE TROUBLESHOOTING (continued)

SYMPTOM	POSSIBLE PROBLEM	SOLUTION
Operation not satisfactory		
Rotational speed fluctuates.	Governor adjustment improper?	Adjust governor to correct lever.
	Governor spring defective?	Clean or replace ignition.
	Fuel flow erratic?	Check fuel line.
	Air taken in through suction line?	Check suction line.
Recoil starter not working properly.	Dust in rotating part?	Clean recoil starter assembly.
	Spiral spring failure?	Replace spiral spring.

TABLE 5. RAMMER TROUBLESHOOTING

SYMPTOM	POSSIBLE PROBLEM	SOLUTION
Engine rotates but amplitude not uniform or does not strike.	Operating speed of throttle lever is incorrectly set?	Set throttle lever to correct position.
	Oil in excess?	Drain excess oil. Bring to correct level.
	Clutch slips?	Replace or adjust clutch.
	Spring Failure?	Replace spiral spring.
	Speed of engine improper?	Adjust engine speed to correct operating RPM setting.

MT-84F — EXPLANATION OF PARTS SECTION REMARKS

The following section explains the different symbols and remarks used in the Parts section of this manual. Use the help numbers found on the back page of the manual if there are any questions.

The contents and part numbers listed in the parts section are subject to change **without notice**. Multiquip does not guarantee the availability of the parts listed.

Sample Parts List:

NO.	PART NO.	PART NAME	QTY.	REMARKS
1	12345	BOLT	1	INCLUDES ITEMS W/*
2*		WASHER, 1/4 IN.		NOT SOLD SEPARATELY
2*	12347	WASHER, 3/8 IN.	1	MQ-45T ONLY
3	12348	HOSE	A/R ..	MAKE LOCALLY
4	12349	BEARING	1	S/N 2345B AND ABOVE

NO. Column

Unique Symbols - All items with same unique symbol (*, #, +, %, or >) in the number column belong to the same assembly or kit, which is indicated by a note in the “Remarks” column.

Duplicate Item Numbers - Duplicate numbers indicate multiple part numbers are in effect for the same general item, such as different size saw blade guards in use or a part that has been updated on newer versions of the same machine.

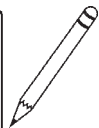
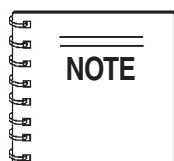

When ordering a part that has more than one item number listed, check the remarks column for help in determining the proper part to order.

PART NO. Column

Numbers Used - Part numbers can be indicated by a number, a blank entry, or TBD.

TBD (To Be Determined) is generally used to show a part that has not been assigned a formal part number at time of publication.

A blank entry generally indicates that the item is not sold separately or is not sold by Multiquip. Other entries will be clarified in the “Remarks” Column.

QTY. Column

Numbers Used - Item quantity can be indicated by a number, a blank entry, or A/R.

A/R (As Required) is generally used for hoses or other parts that are sold in bulk and cut to length.

A blank entry generally indicates that the item is not sold separately. Other entries will be clarified in the “Remarks” Column.

REMARKS Column

Some of the most common notes found in the “Remarks” Column are listed below. Other additional notes needed to describe the item can also be shown.

Assembly/Kit - All items on the parts list with the same unique symbol will be included when this item is purchased.

Indicated by:

“INCLUDES ITEMS W/(unique symbol)”

Serial Number Break - Used to list an effective serial number range where a particular part is used.

Indicated by:

“S/N XXXXX AND BELOW”

“S/N XXXX AND ABOVE”

“S/N XXXX TO S/N XXX”

Specific Model Number Use - Indicates that the part is used only with the specific model number or model number variant listed. It can also be used to show a part is NOT used on a specific model or model number variant.

Indicated by:

“XXXXX ONLY”

“NOT USED ON XXXX”

“Make/Obtain Locally” - Indicates that the part can be purchased at any hardware shop or made out of available items. Examples include battery cables, shims, and certain washers and nuts.

“Not Sold Separately” - Indicates that an item cannot be purchased as a separate item and is either part of an assembly/kit that can be purchased, or is not available for sale through Multiquip.

MT-84F RAMMER 1 TO 3 UNITS

QTY	PART NO	DESCRIPTION
1	362455630	LEVER, THROTTLE
1	956100045	THROTTLE WIRE
3	354030030	ELEMENT, YELLOW
3	354030040	ELEMENT, GRAY
1	361910070	CAP, FUEL TANK W/STRAP
1	954300720	COCK, FUEL ASSY.
2	301419750	FILTER, IN-LINE FUEL
3	2523260107	ELEMENT, SET ENGINE
1	0660000371	STOP SWITCH ASSY
3	0650140580	SPARK PLUG
1	954406010	STRAINER, FUEL TANK
1	2695011008	ROPE, RECOIL STARTER

MT-84F RAMMER 3 TO 5 UNITS

QTY	PART NO	DESCRIPTION
1	362455630	LEVER, THROTTLE
1	956100045	THROTTLE WIRE
5	354030030	ELEMENT, YELLOW
5	354030040	ELEMENT, GRAY
2	354336352	CLAMP, BELLOWS
2	354010010	BELLOWS
1	361910070	CAP, FUEL TANK W/STRAP
1	954300720	COCK, FUEL ASSY.
5	301419750	FILTER, IN-LINE FUEL
5	2523260107	ELEMENT, SET ENGINE
1	0660000371	STOP SWITCH ASSY
5	0650140580	SPARK PLUG
1	954406010	STRAINER, FUEL TANK
1	2695011008	ROPE, RECOIL STARTER

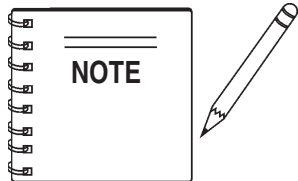

Part number on this Suggested Spare Parts List may super cede/replace the P/N shown in the text pages of this book.

NAME PLATE AND DECALS

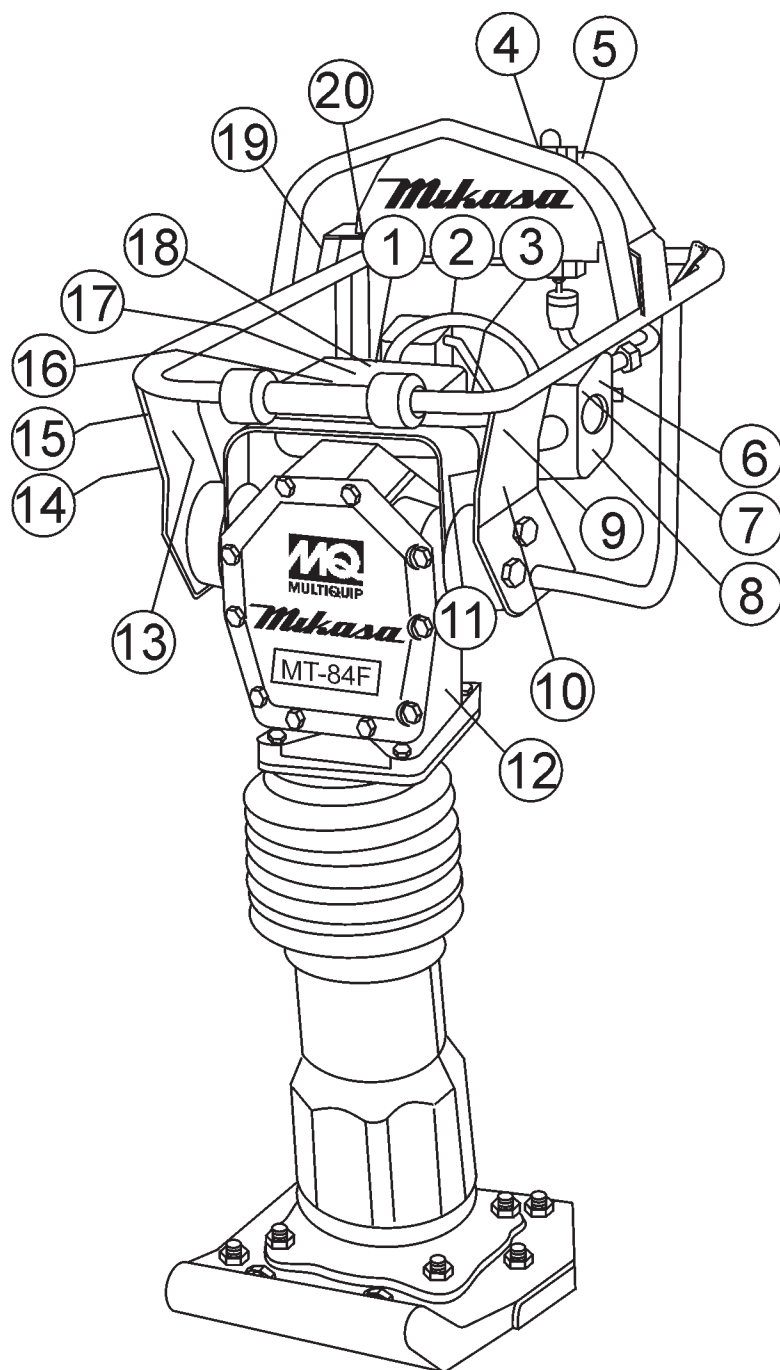

MT-84F— NAMEPLATE AND DECALS

NAME PLATE AND DECALS

<u>NO</u>	<u>PART NO</u>	<u>PART NAME</u>	<u>QTY.</u>	<u>REMARKS</u>
1	920210150	DECAL: 3500 ~ 3700 RPM.....	1	NPA1015
2	920203990	DECAL: CLOSE FUEL COCK	1	NPA-399
3	920202930	DECAL: START SWITCH	1	NPA-293
4	920202930	DECAL: GASOLINE ONLY	1	NPA-1017
5	920208960	DECAL: GASOLINE ONLY TAG	1	NPA-896
6	920108310	DECAL: CLEANER ELEMENT	1	NPA-831
7	920203980	DECAL: ELEMENT SET	1	NPA-398
8	920210160	DECAL: SERVICE MONTHLY	1	NPA-1016
9	TBD	DECAL: WARNING READ	1	
10	0732004450	DECAL: CAUTION	1	
11	920203290	DECAL: READ MANUAL	1	NPA-329
12		NAMEPLATE	1	CONTACT MQ PARTS DEPT.
13	920107000	DECAL: PRE-CLEANER	1	NP-700
14	920209100	DECAL: CAUTION RAMMER	1	NPA-910
15	920207690	DECAL: CAUTION MANUAL	1	NPA-769
16	920210180	DECAL: CHECK DAILY (FILTER)	1	NPA-1018
17	920209750	DECAL: CAUTION 4-CYCLE	1	NPA-975
18	920204370	DECAL: PRE-CLEANER	1	NPA-437
19	920203330	DECAL: EAR PROTECTION	1	NPA-333
20	920100240	DECAL: MIKASA LOGO	1	

MT-84F — CRANKCASE AND ENGINE ASSY.

CRANKCASE AND ENGINE ASSY.

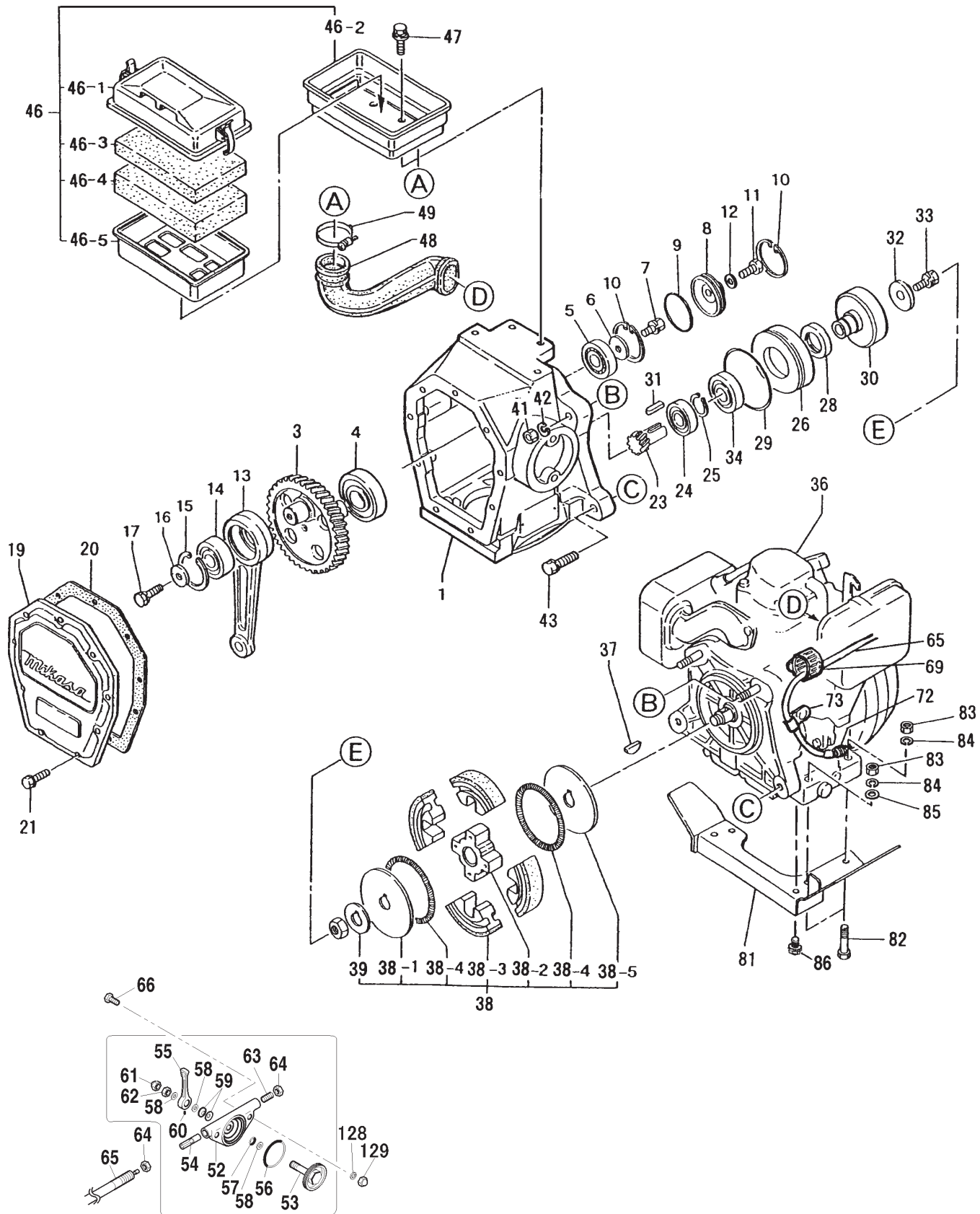

MT-84F — CRANKCASE AND ENGINE ASSY.

CRANKCASE AND ENGINE ASSY.

<u>NO.</u>	<u>PART NO.</u>	<u>PART NAME</u>	<u>QTY.</u>	<u>REMARKS</u>
1	361117380	CRANK CASE	1	
3	361335870	CRANK GEAR	1	
4	040006207	BEARING 6207	1	
5	040006204	BEARING 6204	1	
6	952400130	WASHER 9304	1	
7	002210825	BOLT 8X25 H, SW	1	
8	371447650	BEARING COVER	1	
9	050300480	O-RING S-48	1	
10	080100480	STOP RING R-48	2	
11	001220610	BOLT 6X10 T	1	
11-1	001200610	BOLT 6X110	1	
12	031106100	WASHER M5	1	
13	371334730	CONNECTING ROD	1	
14	040006304	BEARING 6304	1	
15	080100520	STOP RING R-52	1	
16	952400130	WASHER 9304	1	
17	002210825	BOLT 8X25 H, SW	1	
19	361010070	PACKING, FRONT COVER	1	
20	352444450	PACKING, FRONT COVER	1	
21	002210620	BOLT 6X20 H, SW	9	
23	361449320	PINION	1	
24	040006204	BEARING 6204	1	
25	080200350	STOP RING S-35	1	
26	371449600	SPACER	1	
28	060404010	OIL SEAL TC-40528	1	
29	050101000	O-RING G-100	1	
30	361449330	CLUTCH DRUM	1	
31	952405610	KEY 5X5X19R	1	
32	952405490	LOCK WASHER	1	
33	002210820	BOLT 8X20 H, SW	1	
34	041006007	BEARING 6007Z	1	
36	911211202	ENGINE ASSY., EH12-2D EPA	1	
37	0053204201	WOODRUFF KEY	1	
38	362454441	CLUTCH ASSY. CE120P 1.6T	1	INCLUDES ITEMS W/*
38-1*	943060020	CLUTCH GUIDE/B	1	
38-2*	943050050	CLUTCH BOSS C812	1	
38-3*	943020020	CLUTCH SHOE C812	4	
38-4*	943030021	CLUTCH SPRING C812	2	
38-5*	943060100	CLUTCH GUIDE/A 1.6T,1C	1	
39*	301010210	WASHER, LOCK CLUTCH	1	

MT-84F — CRANKCASE AND ENGINE ASSY.

CRANKCASE AND ENGINE ASSY. CONTINUED

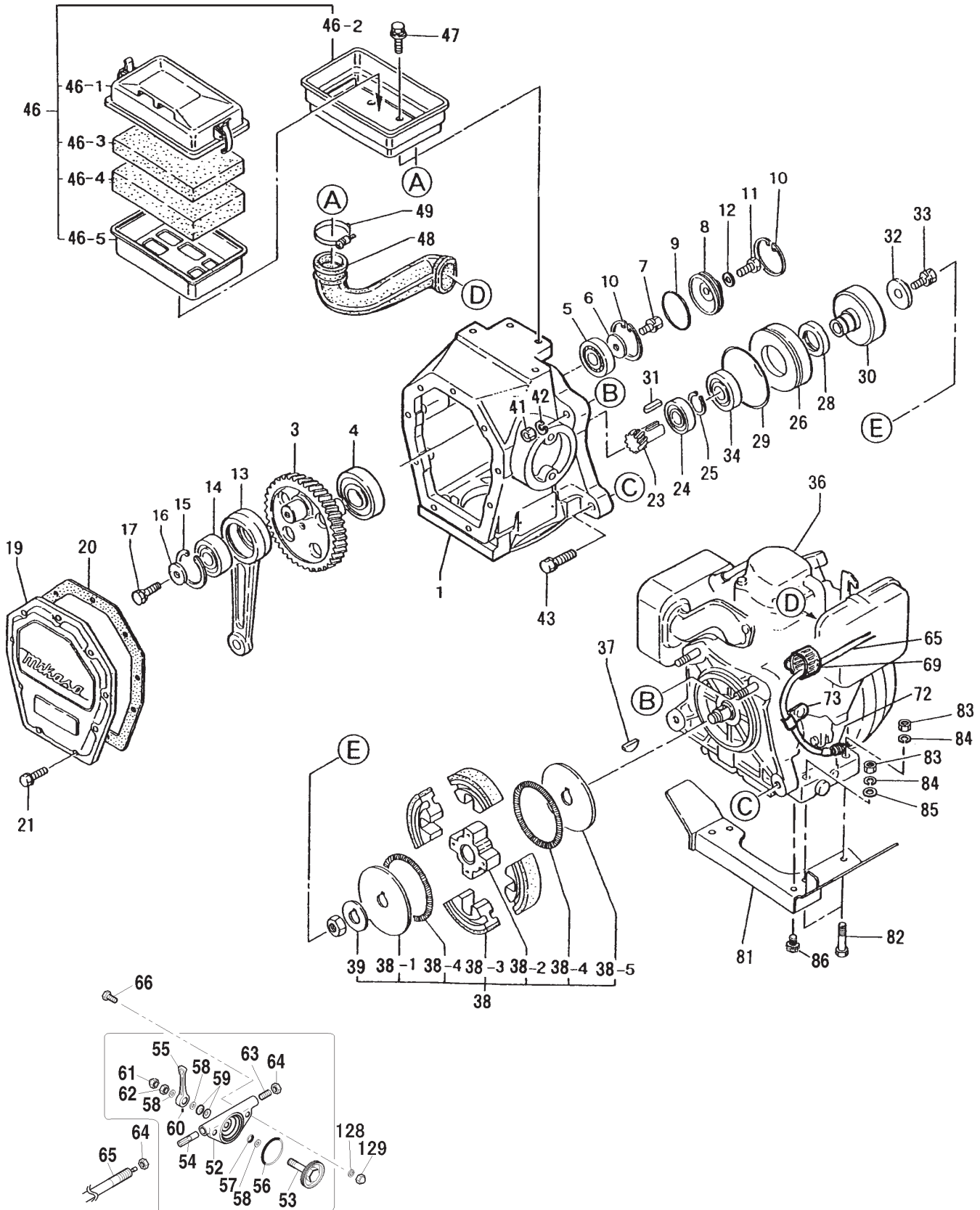

MT-84F — CRANKCASE AND ENGINE ASSY.

CRANKCASE AND ENGINE ASSY. CONTINUED

<u>NO</u>	<u>PART NO</u>	<u>PART NAME</u>	<u>QTY.</u>	<u>REMARKS</u>
41	020310080	NUT M10	2	
42	030210250	SW M10	2	
42-1	030210250	SW M10	4	
43	002211050	BOLT 10X50 H, SW	2	
43-1	001221050	BOLT 10X50 T	2	
46	361213800	AIR CLEANER ASSY	1	INCLUDES ITEMS W/#
46-1#	354030011	BODY /W-CLEANER	1	
46-2#	361010020	BACK PLATE CP	1	
46-3#	354030030	ELEMENT, YELLOW	1	
46-4#	354030040	ELEMENT, GRAY	1	
47-5#	354030050	ELEMENT FRAME	1	
47	002210820	BOLT 8X20 H, SW	4	
47-1	002200820	BOLT 8X20 , SW	4	
48	361336010	INTAKE PIPE	1	
49	954010230	HOSE BAND (B), AH-1032	1	
52	362341550	THROTTLE BODY	1	
53	362455610	THROTTLE GEAR	1	
53-1	362910090	THROTTLE GEAR CP, W/BOLT	1	
54	362455620	SLIDER	1	
55	362455630	THROTTLE LEVER	1	
56	050100450	O-RING G-45	1	
57	050200100	O-RING P-10	1	
58	031110160	PW M10	3	
59	032110180	CONICAL SPRING WASHER M10	2	
60	096206006	SOCKET HEAD SCREW 6X6	1	
61	022131008	CAP NUT M10	1	
62	020410060	NUT M10, H=6	1	
63	096208020	SOCKET HEAD SCREW 8X20	1	
64	020408050	NUT M8, H=5	2	
65	956100045	THROTTLE WIRE, S680-780/84	1	
66	001220620	BOLT 6X20 T	2	
67	030206150	WASHER, LOCK M6	2	
68	022130605	CAP NUT M6	2	
69	30310450	BAND	1	
72	0830000010	COIL SPRING	1	
73	959006120	CLIP, TCP2-10509B	1	
81	361214201	UNDER PROTECTOR	1	
82	001220840	BOLT 8X40 T	3	
83	020308060	NUT M8	3	
84	030208200	WASHER, LOCK M8	3	
85	031108160	WASHER, FLAT M8	3	
86	0011308180	BOLT & WASHER ASSY.	2	

MT-84F — GUIDE CYLINDER AND FOOT ASSY.

GUIDE CYLINDER AND FOOT ASSY.

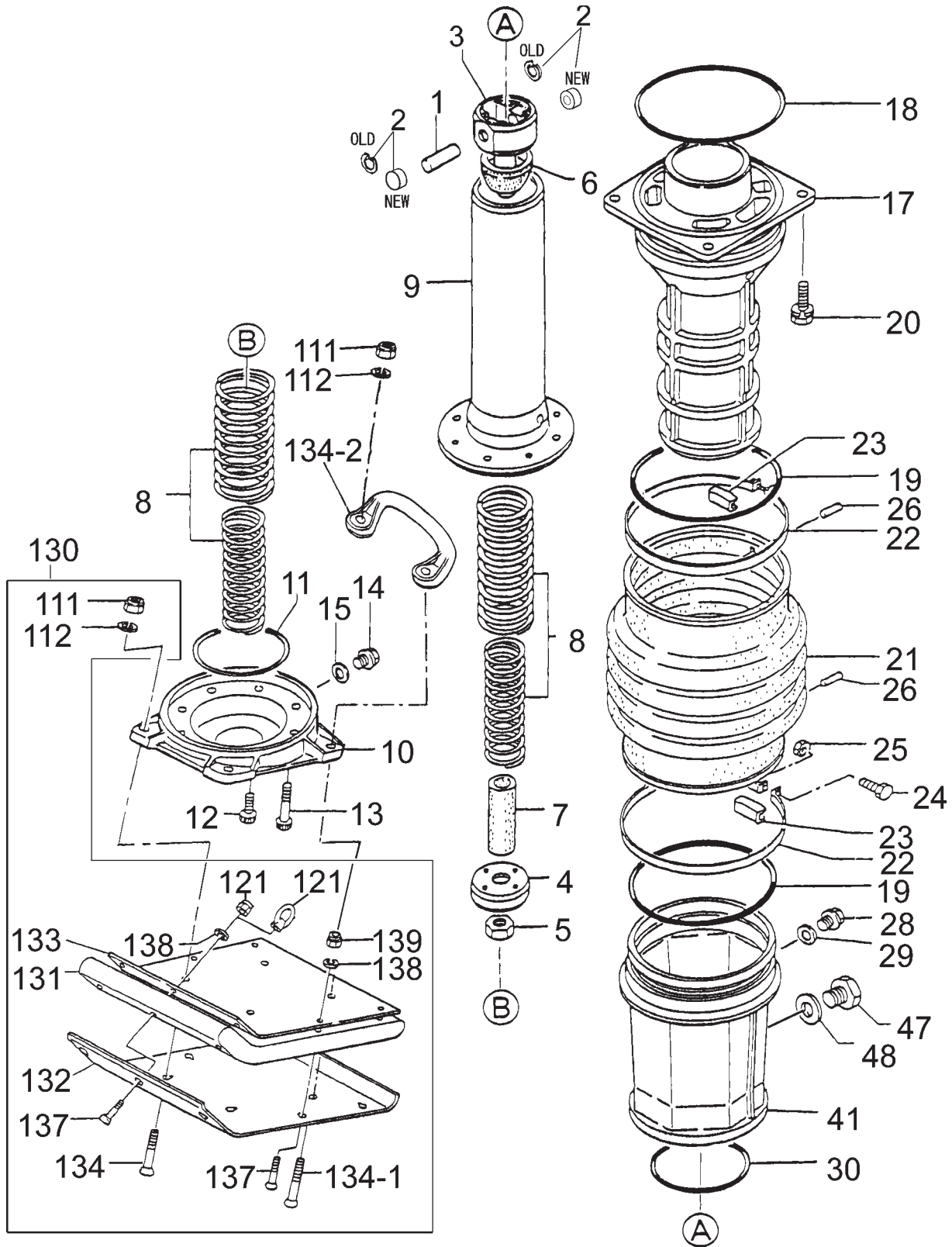

MT-84F — GUIDE CYLINDER AND FOOT ASSY.

GUIDE CYLINDER AND FOOT ASSY.

<u>NO.</u>	<u>PART NO.</u>	<u>PART NAME</u>	<u>QTY.</u>	<u>REMARKS</u>
1	352423290	PISTON PIN	1	
2	080100150	STOP RING R-15	1	S/N M1372 AND BELOW
2	080100150	STOP RING R-15	1	S/N M1373 AND ABOVE
3	355338690	PISTON ROD	1	
4	355452340	PISTON END	1	
5	020118150	NUT M18, P1.5	1	
6	355447250	STOPPER UPPER	1	
7	355447260	STOPPER, LOWER	1	
8	355447270	MAIN SPRING	2	
9	355334310	SPRING CYLINDER	1	
10	355214140	FOOT PLATE, 14	1	
11	050100900	O-RING G-90	1	
12	001521020	SOCKET HEAD BOLT 10X20 T	4	
13	001521040	SOCKET HEAD BOLT 10X40 T	4	
14	953405270	PLUG 1/4X14 13L	1	
15	953405260	PACKING 1/4 (CU)	1	
17	355213010	GUIDE CYLINDER	1	
18	050201500	O-RING P-150	1	
19	002211035	BOLT 10X35 H, SW	4	
21	354010010	BELLOWS, ORANGE	1	
22	050931500	O-RING JASO3150	2	
23	354336352	BELLOWS CLAMP, 1.6T 171D	2	
24	35442340	BAND GUIDE, BELLOWS	2	
25	001210840	BOLT 8X40 H	2	REPLACES 001220840
26	020308060	NUT M8	2	
27	354446170	PIN 6D-8.5L	2	
28	953405270	PLUG 1/4X14 13L	2	
29	953405260	PACKING 1/4 (CU)	2	
30	050100950	O-RING G-95	1	
41	355113960	PROTECTION SLEEVE	1	
47	959010150	LEVEL GAUGE, PLUG TYPE	1	
48	953404670	COPPER PACKING 17X25.5X1	1	
100	361910050	FOOT ASSY 285W, S80	1	INCLUDES ITEMS W/*
111	0227112174	NYLON NUT M12	4	
112	030212300	WASHER, LOCK M12	4	
131*	352108220	FOOT 285B-331L	1	
132*	352108230	METAL SHEET	1	
133*	352333380	FOOT COVER	1	
134	001611253	SUNK HEAD BOLT 12X65 H	4	
134-1	001611253	SUNK HEAD BOLT 12X65 H	2	
134-2	001611259	SUNK HEAD BOLT 12X95 H	2	
134-3	363343390	HANDLE	1	
137*	001611051	SUNK HEAD BOLT 10X55 H	7	
138*	030210250	WASHER, LOCK M10	7	
139*	022711012	NYLON NUT M10	7	

MT-84F — TANK AND HANDLE ASSY.

TANK AND HANDLE ASSY.

<u>NO</u>	<u>PART NO</u>	<u>PART NAME</u>	<u>QTY.</u>	<u>REMARKS</u>
1	361117410	HANDLE	1	REPLACES 361117750
2	351319900	SHOCK ABSORBER	2	
3	009110007	GT CAP SA, 10X20	4	
3-1	014210020	SOCKET HEAD BOLT 10X20T	4	REPLACES 001521020
3-2	033121009	TOOTH LOCKED WASHER BM10	4	
4	002211020	BOLT 10X20 H, SW	4	
6	361910070	TANK CAP ASSY., OR,DB	1	INCLUDES ITEM W/*
6-1	361455740	SUB. CAP, B	1	
6-2	920208960	TAG, GASOLINE	1	
7	351437735	HOLDER, COCK	1	
8	954406020	PACKING, FUEL TANK	1	
9	954406010	STRAINER, #110	1	
11	011208030	BOLT 8X30 T	2	REPLACES 001220830
12	030208200	WASHER, LOCK M8	2	
13	022710809	NYLON NUT M8	2	
14	952401450	WASHER 8.5X22X3	2	
23	353432250	CAP	1	
26	361116910	FUEL TANK, 2.5L P, G	1	
27	954300720	FUEL COCK ASSY. CVL-08	1	
28*	353449010	STRAP, OIL TANK	1	
29	009110014	PAN HEAD SCREW 8X10	2	
32	954406420	HOSE BAND 10.5	2	
36	351435160	FUEL HOSE B-95	1	
37	351436350	FUEL HOSE R-15OL D8	1	
38	954404590	HOSE BAND 9.5D	2	
39	954403030	HOSE BAND, 8	2	
40	301419750	FUEL FILTER CP	1	
46	955200052	ROLLER, W/PIN	2	
46-1	955200053	ROLLER, W/PIN	2	
47	091005025	SCREW 5X25	4	
48	022610505	FLANGE NUT, M5 H	4	
49	031105080	WASHER, FLAT M5	4	

ROBIN EH-12-2D ENGINE — CRANKCASE AND CYLINDER ASSY.

CRANKCASE AND CYLINDER ASSY.

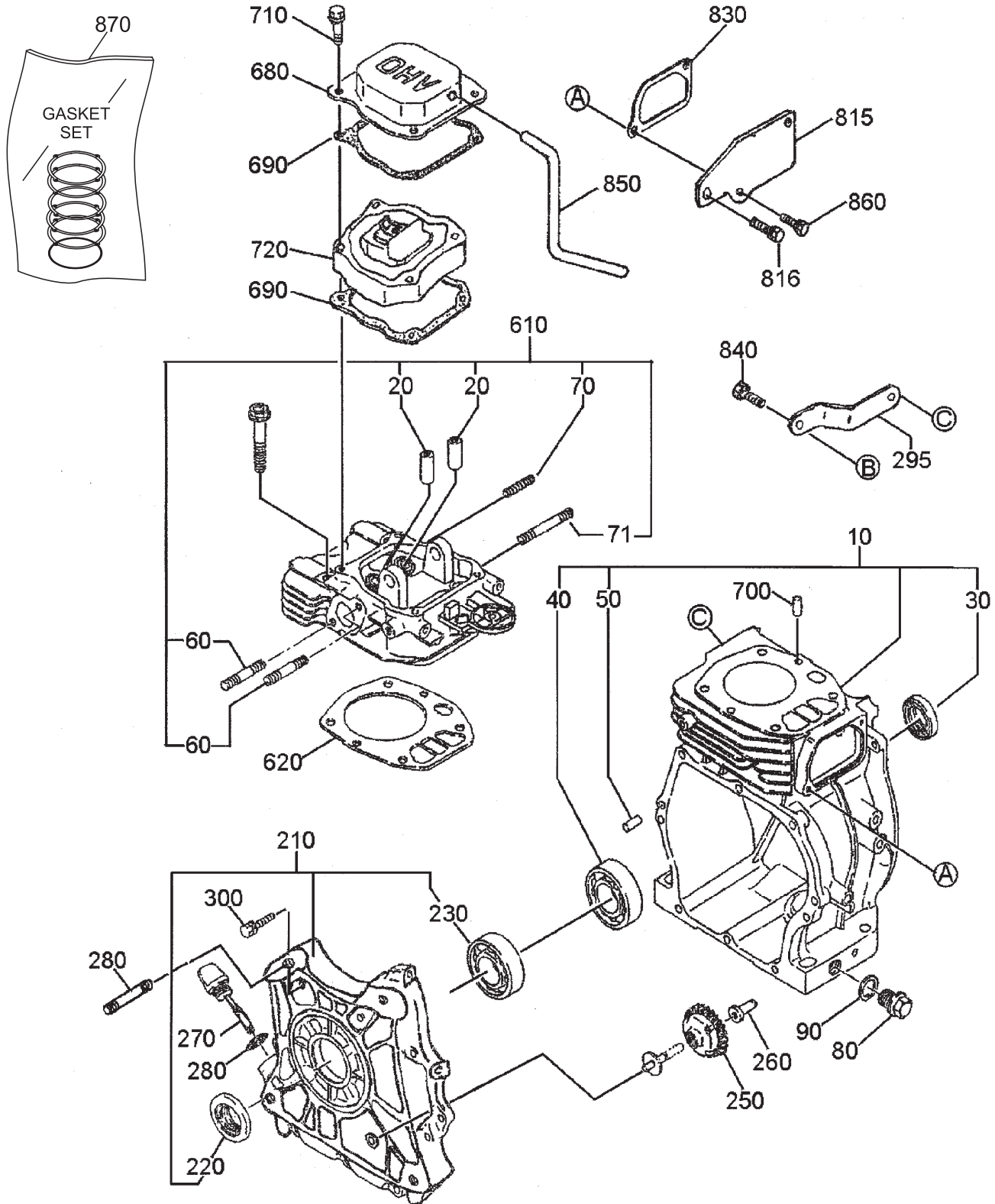

ROBIN EH-12-2D ENGINE — CRANKCASE AND CYLINDER ASSY.

CRANKCASE AND CYLINDER ASSY.

<u>NO.</u>	<u>PART NO.</u>	<u>PART NAME</u>	<u>QTY.</u>	<u>REMARKS</u>
10	2521030111	CRANK CASE	1	INCLUDES ITEMS W/\$
20+	2371420203	VALVE GUIDE, OVERSIZE	2	
26	2371600801	VALVE, STEM SEAL	1	
30\$	0440250150	OIL SEAL	1	
40\$	0600250010	BALL BEARING 6205C3	1	
50\$	0310060020	DOWEL PIN	2	
60+	0105080480	STUD	2	
70+	0105060131	STUD	1	
71+	0013906600	STUD	1	
80	0401140030	PLUG	2	
90	0211140020	GASKET	2	
210	2521110121	MAIN BEARING COVER CP	1	INCLUDES ITEMS W/#
220#	0440250160	OIL SEAL	1	
230#	0600250010	BALL BEARINGS 6205C3	1	
250	2274500301	GOVERNOR GEAR COMPL	1	
260	2054190103	GOVERNOR SLEEVE	1	
265	0108100020	STUD	2	
270	2526360101	OIL GAUGE CP	1	
280	0213160020	GASKET	1	
295	2521700101	SUPPORT (M.B.C)	1	
296	0566000250	CLAMP	1	
297	0110060020	FLANGE BOLT	1	
300	0130060200	BOLT & WASHER ASSY	8	
610	2681300301	CYLINDER HEAD CP	1	INCLUDES ITEMS W/+
620	2531500123	GASKET, HEAD	1	
630	0110080100	FLANGE BOLT	4	
680	2521550203	ROCKER COVER	1	
690	2691600403	GASKET, ROCKER COVER	2	
700	0310060020	DOWEL PIN	2	
710	0110060170	FLANGE BOLT EY45V	4	
720	2521560110	SPACER ASSY, BREATHER	1	INCLUDES ITEMS W/*
721*	2521560103	SPACER, BREATHER	1	
722*	2521600103	LEAF VALVE	1	
723*	2521610103	RETAINER PLATE	1	
724*	2521440113	PLATE	1	
725*	0110060150	FLANGE BOLT EH11	2	
726*	0043506120	SCREW & WASHER	1	
815	2521700201	BRACKET CP (M.B.C)	1	
816	0011308160	BOLT & WASHER ASSY	1	
830	2531600633	GASKET, BREATHER COVER	1	
840	0011308160	BOLT & WASHER ASSY	2	
850	2521800203	RUBBER PIPE	1	
860	0011306160	BOLT AND WASHER ASSY.	2	
870	2529900107	GASKET SET	1	

ROBIN EH-12-2D ENGINE — CRANKSHAFT AND PISTON ASSY.

CRANKSHAFT AND PISTON ASSY.

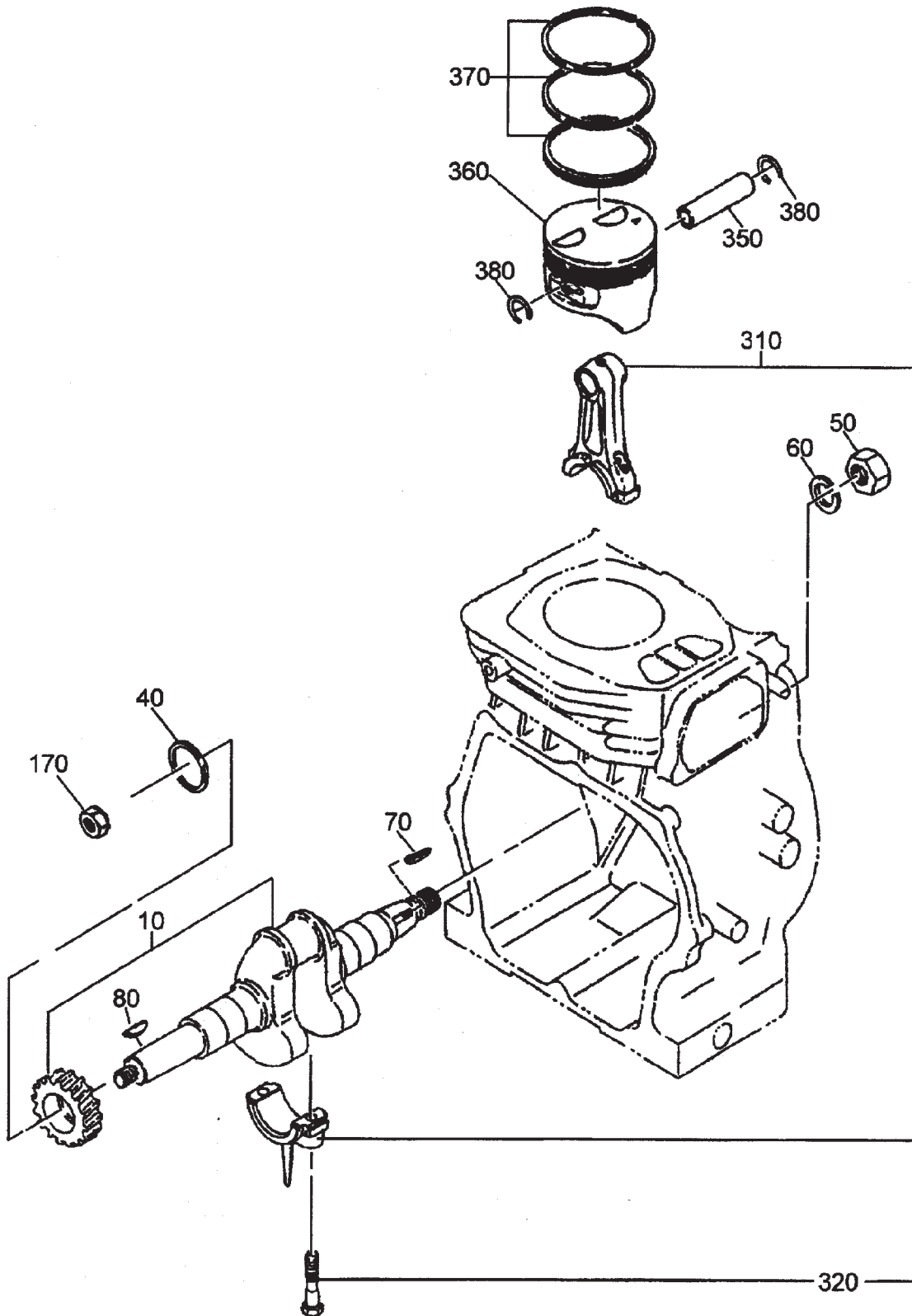

ROBIN EH-12-2D ENGINE — CRANKSHAFT AND PISTON ASSY.

CRANKSHAFT AND PISTON ASSY.

<u>NO.</u>	<u>PART NO.</u>	<u>PART NAME</u>	<u>QTY.</u>	<u>REMARKS</u>
10	EH122R0029	CRANKSHAFT CP	1	
40	0230250110	SPACER T=0.6	1	
40	0230250120	SPACER T=0.8	1	
40	0230250130	SPACER T=1.0	1	
50	0021814000	NUT	1	
60	0032014000	SPRING WASHER	1	
70	0323030010	WOODRUFF KEY	1	
80	0053204201	WOODRUFF KEY	1	
170	0173120010	LOCK NUT	1	
310	2522250110	CONNECTING ROD ASSY	1	INCLUDES ITEMS W/*
320*	2362300103	CONNECTING ROD BOLT	2	
350	2682330103	PISTON PIN	1	
360	2682340103	PISTON STD.	1	
360	2682340203	PISTON O.S. 0.25MM	1	
360	2682340303	PISTON O.S. 0.50MM	1	
370	2522350107	PISTON RING SET STD	1	
370	2522350207	PISTON RING SET 0.25 O.S.	1	
370	2522350307	PISTON RING SET 0.50 O.S.	1	
380	2152500403	CLIP	2	

ROBIN EH-12-2D ENGINE—MUFFLER, AIR CLEANER, CAM & CARB. ASSY.

MUFFLER, AIR CLEANER, CAMSHAFT & CARBURETOR ASSY.

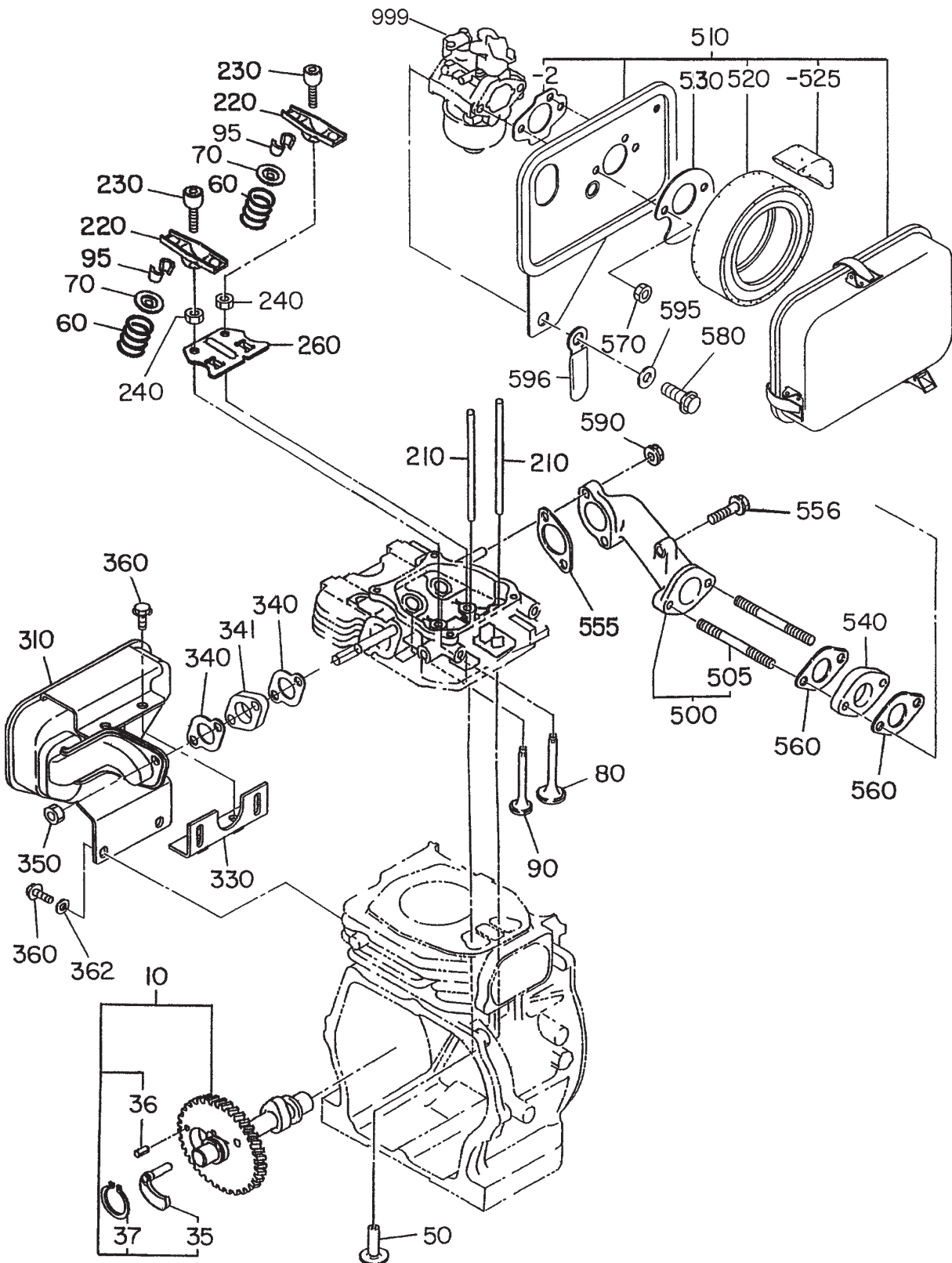

ROBIN EH-12-2D ENGINE —MUFFLER, AIR CLEANER, CAM& CARB. ASSY.

MUFFLER, AIR CLEANER, CAMSHAFT & CARBURETOR ASSY.

<u>NO.</u>	<u>PART NO.</u>	<u>PART NAME</u>	<u>QTY.</u>	<u>REMARKS</u>
10	2533170111	CAMSHAFT CP	1	INCLUDES ITEMS W/*
35	2273640103	RELEASE LEVER	1	
36	0051904100	SPRING PIN	1	
37	0031522000	SNAP RING	1	
50	2393330113	TAPPET	2	
60	2533360103	VALVE SPRING	2	
70	13209KAO40	RETAINER VALVE SPRING	2	
80	2683340103	INTAKE VALVE	1	
90	2683350103	EXHAUST VALVE	1	
95	13210KAO31	COLLECT VALVE	4	
210	2683530103	PUSH ROD	2	
220	26136001A3	ROCKER ARM	2	
230	2693580103	BOLT, PIVOT	2	
240	0170060090	NUT	2	
260	2693650103	GUIDE PLATE	1	
310	2523040111	MUFFLER CP	1	
330	2523700111	BRACKET CP	1	
340	2533520103	GASKET, MUFFLER	2	
341	2523650103	SPACER, EXHAUST	1	
350	0170080030	NUT	2	
360	0011308160	BOLT & WASHER ASSY	4	
362	0031108000	WASHER	2	
500	2523300311	INTAKE PIPE CP	1	INCLUDES ITEMS W/\$
505\$	0105060230	STUD	2	
510	2523271110	AIR CLEANER ASSY	1	INCLUDES ITEMS W/%
510-2%	2263272008	GASKET (AIR CLEANER)	1	
520%	2523260107	ELEMENT, SET	1	
525%	2523261108	ELEMENT	1	
530	2523650203	PLATE, AIR CLEANER	1	
540	1063291203	INSULATOR	1	
555	2273590103	GASKET (INSULATOR)	1	
556	0011406400	BOLT AND WASHER ASSY	1	
560	2363590303	GASKET 2 (INSULATOR)	2	
570	0176060020	SELF LOCK NUT	2	
580	0011308180	BOLT & WASHER ASSY	1	
590	0023706000	FLANGE NUT	2	REPLACES 0023806000
595	0200080080	WASHER	1	
596	0566000170	CLAMP	1	
999	2526253110	CARBURETOR ASSY	1	

ROBIN EH-12-2D ENGINE — GOVERNOR ASSY.

GOVERNOR ASSY.

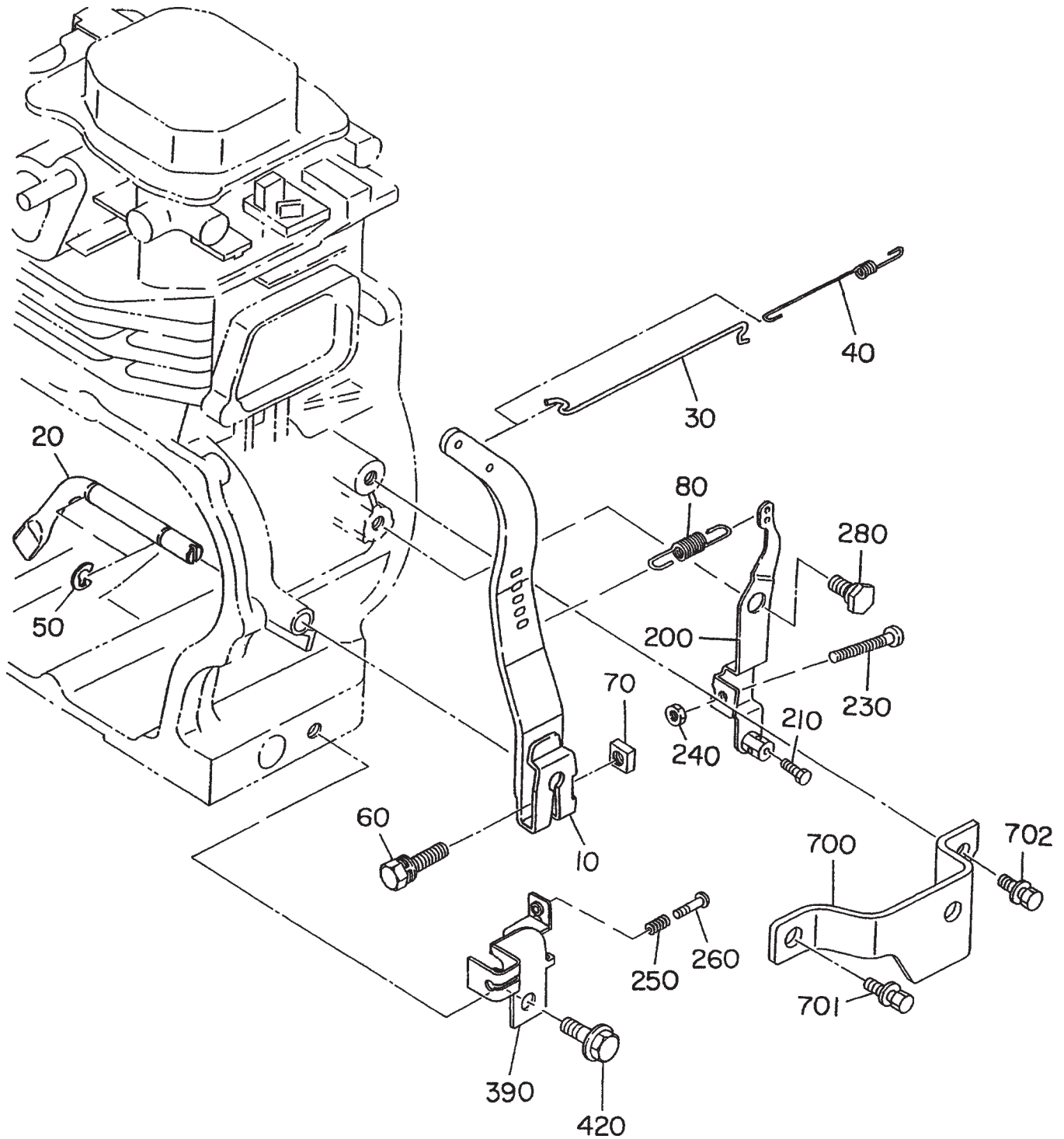

ROBIN EH-12-2D ENGINE —GOVERNOR ASSY.

GOVERNOR ASSY.

<u>NO.</u>	<u>PART NO.</u>	<u>PART NAME</u>	<u>QTY.</u>	<u>REMARKS</u>
10	2524230303	GOVERNOR LEVER CP	1	
20	2264230207	GOVERNOR SHAFT	1	REPLACES 2274220103
30	2544270101	GOVERNOR ROD CP	1	
40	2544280103	ROD SPRING	1	
50	0031306000	CLIP	2	
60	0011406300	BOLT & WASHER ASSY	1	
70	0186060020	NUT	1	
80	2524250323	GOVERNOR SPRING	1	
200	2524340220	SPEED CONTROL ASSY	1	
210	0116040030	BOLT	1	
230	0043105250	SCREW, PANHEAD	1	
240	0021705000	NUT	1	
250	2054600323	CONTROL SPRING	1	
260	0140040020	SCREW	1	REPLACES 0043104250
280	2264310101	LINK PIVOT	1	
390	2524420213	WIRE BRACKET	1	
420	0110060030	FLANGE BOLT	1	
700	2524280111	PROTECTOR CP, GOVERNOR	1	
701	0011308160	BOLT & WASHER ASSY	1	
702	0011306200	BOLT & WASHER ASSY	1	

ROBIN EH-12-2D ENGINE —RECOIL STARTER AND BLOWER ASSY.

RECOIL STARTER AND BLOWER ASSY.

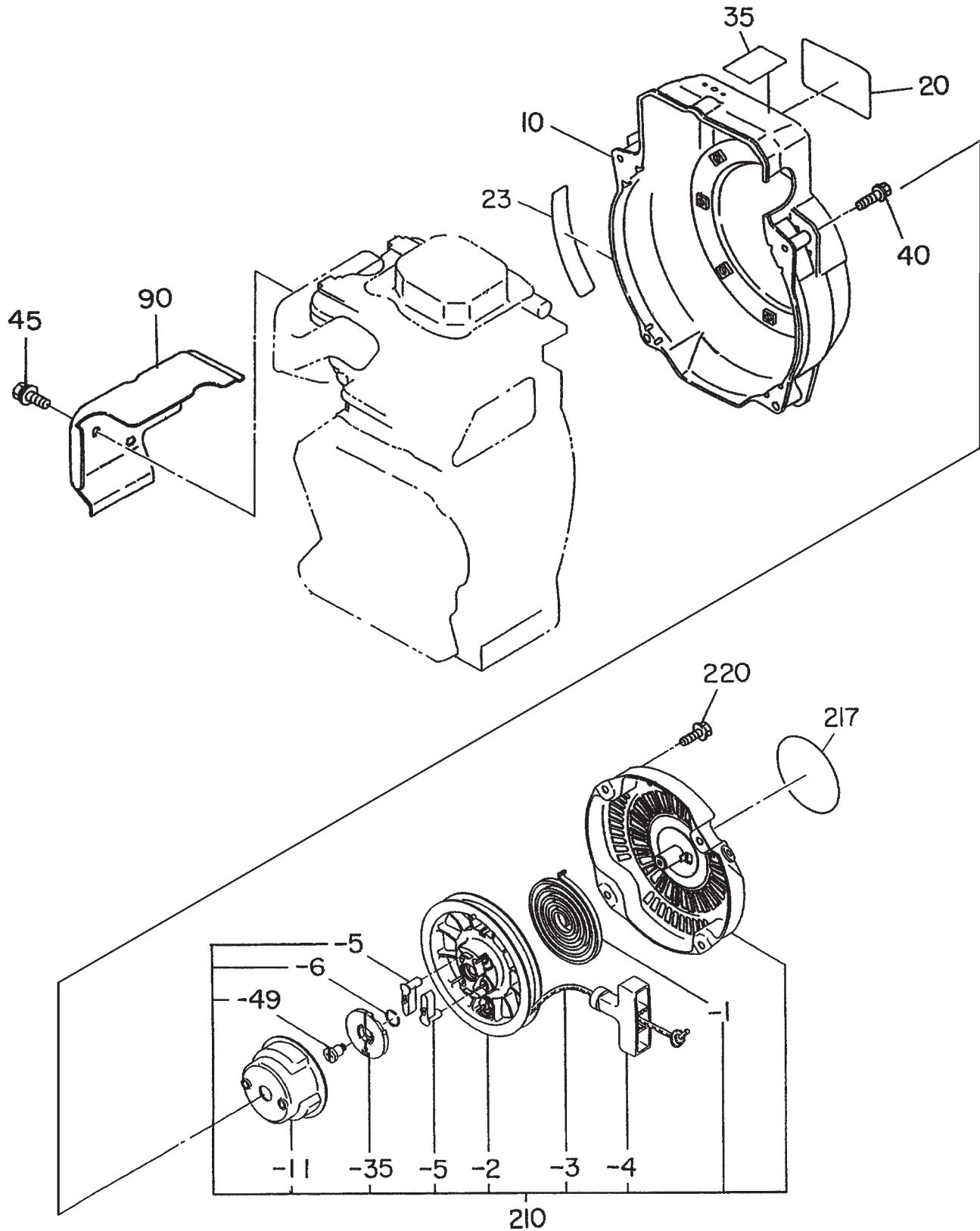

ROBIN EH-12-2D ENGINE —RECOIL STARTER AND BLOWER ASSY.

RECOIL STARTER AND BLOWER ASSY.

<u>NO.</u>	<u>PART NO.</u>	<u>PART NAME</u>	<u>QTY.</u>	<u>REMARKS</u>
10	2525165211	BLOWER HOUSING CP 2	1	
20	2069170103	LABEL, MIKASA MARK	1	
35	2689180203	LABEL, ENGINE NAME	1	
40	0011406550	BOLT & WASHER ASSY	4	
45	0110060140	FLANGE BOLT	2	
90	2525270213	HEAD COVER	1	
210	2685020100	RECOIL STARTER ASSY	1	INCLUDES ITEMS W/*
210-1*	2705011508	SPIRAL SPRING	1	
210-2*	2695012008	REEL	1	
210-3*	2695011008	STARTER ROPE	1	
210-4*	2615010008	STARTER KNOB	1	
210-5*	2705012508	RATCHET	2	
210-6*	2275013108	FRICTION SPRING	1	
210-1*	2685014508	STARTER PULLEY	1	
210-3*	2705026108	RATCHET GUIDE	1	
210-49*	2275015208	SET SCREW	1	
220	0110060050	FLANGE BOLT	4	REPLACES 0110060010

ROBIN EH-12-2D ENGINE — MAGNETO ASSY.

MAGNETO ASSY.

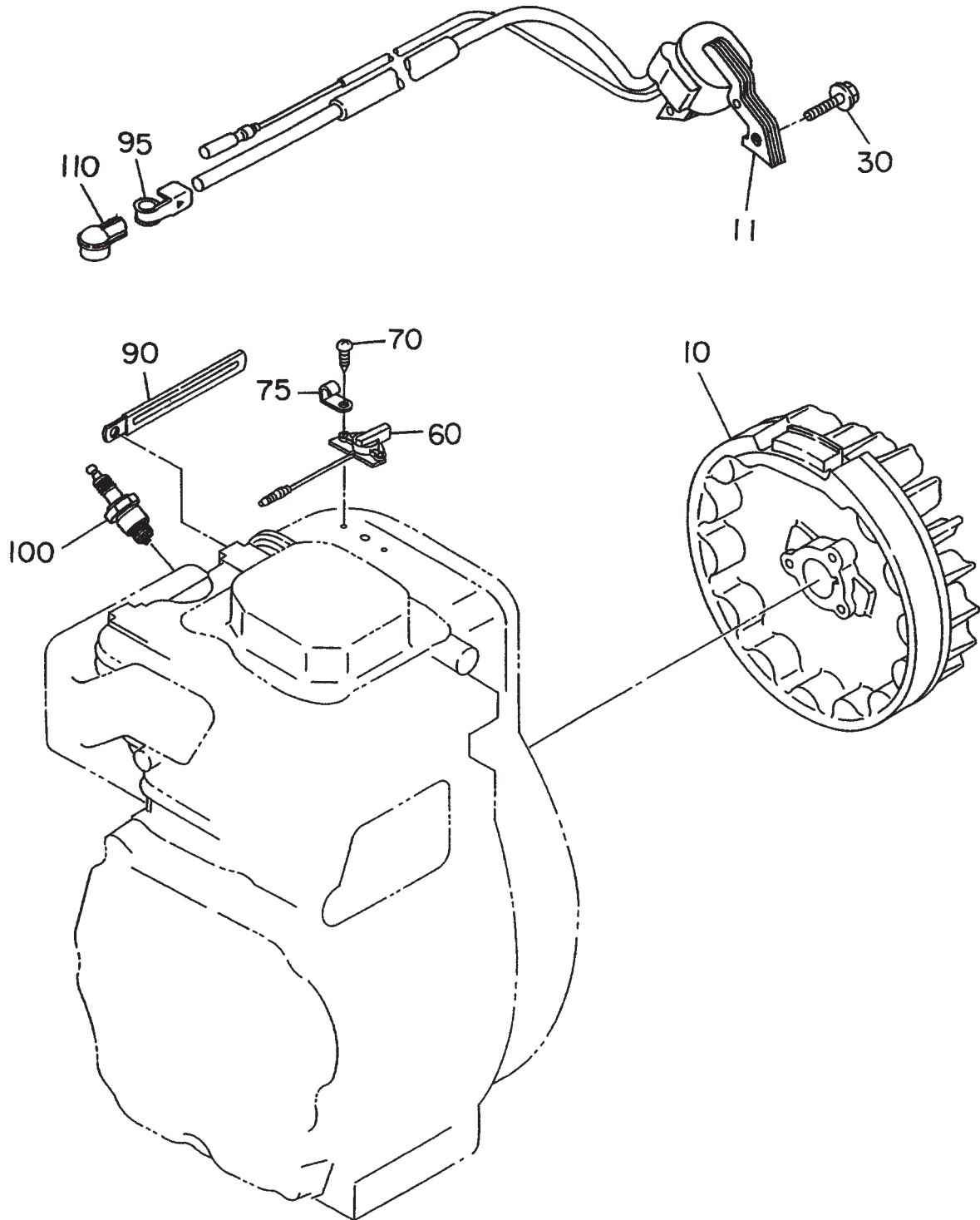

ROBIN EH-12-2D ENGINE — MAGNETO ASSY.

MAGNETO ASSY.

<u>NO</u>	<u>PART NO</u>	<u>PART NAME</u>	<u>QTY.</u>	<u>REMARKS</u>
10	2527933101	FLYWHEEL CP	1	
11	2697943001	IGNITION COIL CP	1	
30	0011406250	BOLT & WASHER ASSY	2	
60	0660000371	STOP SWITCH ASSY (ON-OFF)	1	
70	0150040090	TAPPING SCREW	2	
75	0566030010	CLAMP	1	
90	0566000250	CLAMP	1	
95	0659000010	SPARK PLUG CLIP	1	REPLACES 0655000100
100	0650140100	SPARK PLUG	1	REPLACES 0650140100
110	2307510113	SPARK PLUG CAP	1	

ROBIN EH-12-2D ENGINE — CARBURETOR ASSY.

CARBURETOR ASSY.

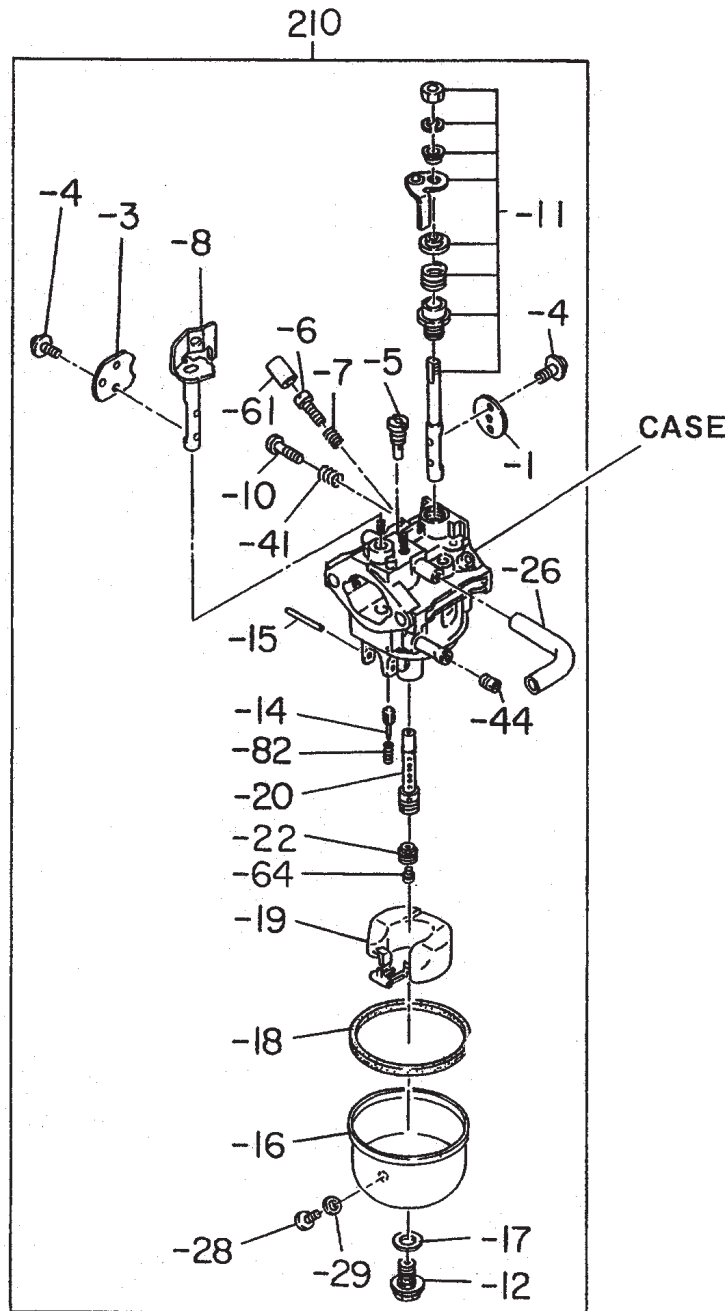

ROBIN EH-12-2D ENGINE — CARBURETOR ASSY.

CARBURETOR ASSY.

<u>NO</u>	<u>PART NO</u>	<u>PART NAME</u>	<u>QTY.</u>	<u>REMARKS</u>
210	2526253120	FLYWHEEL COMPLETE	1	INCLUDES ITEMS W/*
210-1*	2526253508	THROTTLE VALVE	1	
210-3*	2366252808	CHOKE VALVE	1	
210-4*	2376245108	SCREW	4	
210-5*	2166230308	PILOT JET	1	
210-6*	2376243508	PILOT SCREW	1	
210-7*	2306244608	SPRING	1	
210-8*	2526252108	CHOKE SHAFT	1	
210-10*	2466243508	ADJUST SCREW	1	
210-11*	1616253008	THROTTLE SHAFT	1	
210-12*	2366245108	BOLT	1	
210-14*	1616235208	NEEDLE	1	
210-15*	2146251508	PIN	1	
210-16*	2366255208	FLOAT CHAMBER BODY	1	
210-17*	2366245008	PACKING	1	
210-18*	2366254008	PACKING, CHAMBER	1	
210-19*	2366250508	FLOAT	1	
210-20*	2526244008	MAIN NOZZLE	1	
210-22*	2266240308	MAIN JET	1	
210-26*	1616235308	HOSE	1	
210-28*	2366235008	SCREW	1	
210-29*	2366254108	PACKING	1	
210-41*	2096244508	SPRING	1	
210-44*	1616240008	GUIDE HOLDER	1	
210-61*	2466255108	CAP	1	
210-64*	2356242508	MAIN JET	1	
210-82*	2366244508	SPRING	1	

PAYMENT TERMS

Terms of payment for parts are net 10 days.

FREIGHT POLICY

All parts orders will be shipped collect or prepaid with the charges added to the invoice. All shipments are F.O.B. point of origin. Multiquip's responsibility ceases when a signed manifest has been obtained from the carrier, and any claim for shortage or damage must be settled between the consignee and the carrier.

MINIMUM ORDER

The minimum charge for orders from Multiquip is \$15.00 net. Customers will be asked for instructions regarding handling of orders not meeting this requirement.

RETURNED GOODS POLICY

Return shipments will be accepted and credit will be allowed, subject to the following provisions:

1. A Returned Material Authorization must be approved by Multiquip prior to shipment.
2. To obtain a Return Material Authorization, a list must be provided to Multiquip Parts Sales that defines item numbers, quantities, and descriptions of the items to be returned.
 - a. The parts numbers and descriptions must match the current parts price list.
 - b. The list must be typed or computer generated.
 - c. The list must state the reason(s) for the return.
 - d. The list must reference the sales order(s) or invoice(s) under which the items were originally purchased.
 - e. The list must include the name and phone number of the person requesting the RMA.
3. A copy of the Return Material Authorization must accompany the return shipment.
4. Freight is at the sender's expense. All parts must be returned freight prepaid to Multiquip's designated receiving point.

5. Parts must be in new and resalable condition, in the original Multiquip package (if any), and with Multiquip part numbers clearly marked.
6. The following items are not returnable:
 - a. Obsolete parts. (If an item is in the price book and shows as being replaced by another item, it is obsolete.)
 - b. Any parts with a limited shelf life (such as gaskets, seals, "O" rings, and other rubber parts) that were purchased more than six months prior to the return date.
 - c. Any line item with an extended dealer net price of less than \$5.00.
 - d. Special order items.
 - e. Electrical components.
 - f. Paint, chemicals, and lubricants.
 - g. Decals and paper products.
 - h. Items purchased in kits.
7. The sender will be notified of any material received that is not acceptable.
8. Such material will be held for five working days from notification, pending instructions. If a reply is not received within five days, the material will be returned to the sender at his expense.
9. Credit on returned parts will be issued at dealer net price at time of the original purchase, less a 15% restocking charge.
10. In cases where an item is accepted, for which the original purchase document can not be determined, the price will be based on the list price that was effective twelve months prior to the RMA date.
11. Credit issued will be applied to future purchases only.

PRICING AND REBATES

Prices are subject to change without prior notice. Price changes are effective on a specific date and all orders received on or after that date will be billed at the revised price. Rebates for price declines and added charges for price increases will not be made for stock on hand at the time of any price change.

Multiquip reserves the right to quote and sell direct to Government agencies, and to Original Equipment Manufacturer accounts who use our products as integral parts of their own products.

SPECIAL EXPEDITING SERVICE

A \$35.00 surcharge will be added to the invoice for special handling including bus shipments, insured parcel post or in cases where Multiquip must personally deliver the parts to the carrier.

LIMITATIONS OF SELLER'S LIABILITY

Multiquip shall not be liable hereunder for damages in excess of the purchase price of the item with respect to which damages are claimed, and in no event shall Multiquip be liable for loss of profit or good will or for any other special, consequential or incidental damages.

LIMITATION OF WARRANTIES

No warranties, express or implied, are made in connection with the sale of parts or trade accessories nor as to any engine not manufactured by Multiquip. Such warranties made in connection with the sale of new, complete units are made exclusively by a statement of warranty packaged with such units, and Multiquip neither assumes nor authorizes any person to assume for it any other obligation or liability whatever in connection with the sale of its products. Apart from such written statement of warranty, there are no warranties, express, implied or statutory, which extend beyond the description of the products on the face hereof.

OPERATION & PARTS MANUAL

HERE'S HOW TO GET HELP

PLEASE HAVE THE MODEL AND SERIAL
NUMBER *ON-HAND* WHEN CALLING

UNITED STATES

Multiquip Corporate Office

18910 Wilmington Ave. Tel. (800) 421-1244
Carson, CA 90746 Fax (800) 537-3927
Contact: mq@multiquip.com

Mayco Parts

800-306-2926 Fax: 800-672-7877
310-537-3700 Fax: 310-637-3284

Service Department

800-421-1244 Fax: 310-537-4259
310-537-3700

MQ Parts Department

800-427-1244 Fax: 800-672-7877
310-537-3700 Fax: 310-637-3284

Warranty Department

800-421-1244, Ext. 279 Fax: 310-537-1173
310-537-3700, Ext. 279

Technical Assistance

800-478-1244 Fax: 310-631-5032

MEXICO

MQ Cipsa

Carr. Fed. Mexico-Puebla KM 126.5 Tel: (52) 222-225-9900
Momoxpan, Cholula, Puebla 72760 Mexico Fax: (52) 222-285-0420
Contact: pmastretta@cipsa.com.mx

CANADA

Multiquip

4110 Industriel Boul. Tel: (450) 625-2244
Laval, Quebec, Canada H7L 6V3 Fax: (450) 625-8664
Contact: jmartin@multiquip.com

UNITED KINGDOM

Multiquip (UK) Limited Head Office

Hanover Mill, Fitzroy Street, Tel: 0161 339 2223
Ashton-under-Lyne, Fax: 0161 339 3226
Lancashire OL7 0TL
Contact: sales@multiquip.co.uk

BRAZIL

Multiquip

Av. Evandro Lins e Silva, 840 - grupo 505 Tel: 011-55-21-3433-9055
Barra de Tijuca - Rio de Janeiro Fax: 011-55-21-3433-9055
Contact: cnavarro@multiquip.com.br, srentes@multiquip.com.br

© COPYRIGHT 2005, MULTIQUIP INC.

Multiquip Inc, the MQ logo and the Mikasa logo are registered trademarks of Multiquip Inc. and may not be used, reproduced, or altered without written permission. All other trademarks are the property of their respective owners and used with permission.

This manual **MUST** accompany the equipment at all times. This manual is considered a permanent part of the equipment and should remain with the unit if resold.

The information and specifications included in this publication were in effect at the time of approval for printing. Illustrations are based on the *MT-84F Tamping Rammer*. Illustrations, descriptions, references and technical data contained in this manual are for guidance only and may not be considered as binding. Multiquip Inc. reserves the right to discontinue or change specifications, design or the information published in this publication at any time without notice and without incurring any obligations.

Your Local Dealer is:

