



Promise Array™ Management

User Manual

Copyright

Copyright by Promise Technology, Inc. ("Promise"), 2001. No part of this manual may be reproduced or transmitted in any form without the expressed, written permission of Promise.

Trademarks

All trademarks are the property of their respective holders.

Notice

Although Promise has attempted to ensure the accuracy of the content of this manual, it is possible that this document may contain technical inaccuracies, typographical, or other errors. Promise Technology, Inc. assumes no liability for any error in this publication, and for damages, whether direct, indirect, incidental, consequential or otherwise, that may result from such error, including, but not limited to loss of data or profits.

Promise provides this publication "as is" without warranty of any kind, either express or implied, including, but not limited to implied warranties of merchantability or fitness for a particular purpose.

The published information in the manual is subject to change without notice. Promise reserves the right to make changes in the product design, layout, and driver revisions without notification to its users.

Table of Contents

Introduction	1
Promise Technology, Inc.	1
What is Promise Array Management Utility?	1
Key Features	2
System Requirements	2
Operating System Support	2
Promise Array Management™ Setup	4
PAM Installation	4
Custom Installation	4
PAM Installation	5
PAM Administration	9
Creating Message Servers and Agents	9
Adding/Deleting New Users	9
Setting Up A New Array	9
Array Administration	10
Setting Up Email Notification	10
Identifying Problems	10
PAM Quick Reference	10
To Create a New Message Server	10
Accessing Message Agent	11
Creating a New User	11
Deleting an Existing User	11
Creating a New Array	11
Deleting an Existing Array	13
Setting Up E-mail Alert Notification	13
Adding a User to the Current Recipients List	13
Removing a User from the Current Recipients List	13
Adding/Removing Events to/from Email Alert Notification	14
Using PAM	15
Main Window	15
Using Tree View	15
Using Object View	16
Using Information View	17
Using Status Bar	17
PAM Pull-Down Menu/Toolbar	17
Using Pull-Down Menu Items	17
Using View Pull-Down Menu	18
Using Connection Pull-Down Menu	18

Using Preference Pull-Down Menu	19
Using Help Pull-Down Menu	19
Using Help Topics	20
Using PAM Toolbar	21
Console Functions	22
Creating a New Message Server	22
Viewing Console Object icons	23
Message Server Functions	24
Deleting a Message Server	24
Disconnecting a Message Server	24
Connecting the Message Server	25
Switching to another Server	25
Viewing Message Server Object Icons	26
Viewing Message Server Information	26
Message Agent Functions	27
Accessing Message Agent	27
Creating A New User	27
Setting Up E-mail Alert Notification	28
Adding a User to an Email Receiver List	29
Removing a User From an Email Receiver List	29
Adding/Removing Events to/from Email Alert Notification	30
Scheduling Array Synchronization	30
Viewing Message Agent Object icons	31
Message Agent Information View	31
User Management Functions	35
Creating A New User	35
Deleting an Existing User	35
Changing Passwords	36
Assigning User Rights	36
Viewing User/Admin Object icons	36
User Information View	36
I₂O RAID Functions	38
Viewing I ₂ O RAID Object icons	38
Information View	38
Controller (IOPx or FTPx) Functions	39
Creating a New Array	39
Reading/Clearing Events from the RAID Memory Buffer	41
Using The Event Viewer	41
Viewing Controller (IOPx or FTPx) Object icons	42
Controller Information View	42
SuperTrak Options	43
Rebuild Setting	43
Controller Setting	43
Cache Setting	44
Setting Disk Parameters Option	44
FastTrak Options	44
Setting Rebuild Options	44
Setting PCI Bus Utilization Option	44
Setting Disk Parameters Option	45

Channel (chx) Functions	45
Viewing Channel Object icons	45
Hard Drive Functions	45
Hard Drive Information View	45
Enclosure Functions	46
Enabling Rebuild/Synchronization Beeper	46
Viewing Enclosure Object icons	47
Enclosure Information View	47
Array Functions	48
Deleting an Existing Array	48
Rebuilding An Array	48
Using Rebuild Wizard	49
To Stop Rebuild	51
Array Synchronization	51
Halting Synchronization	52
Viewing Array Object icons	52
Information View	53
 Index	 55

Manual Conventions

Common identifiers:

- ↵ - Press the Enter key
- [Key] - Press the key(s) shown within the brackets
- Note:** - Supplementary note containing important information

Common expressions:

- Left-click - Move the mouse cursor over the specified target then click once with the left mouse button.
- Right-click - Move the mouse cursor over the specified target then click once with the right mouse button.
- Double-click - Move the mouse cursor over the specified target then click twice rapidly with the left mouse button.
- Drag and drop - Position the mouse cursor over the indicated icon, depress and hold the left mouse button while moving the cursor. Release the left mouse button to drop the icon at the new location.

NOTES

Introduction

Promise Technology, Inc.

Promise Technology, Inc. was founded in San Jose, California in 1988 and established a proven track record for leading edge storage controller products. With an innovative product line, the company has pioneered ATA RAID storage, allowing users to configure RAID arrays using low-cost Ultra ATA drives. Promise Technology was the first to introduce caching controllers to MFM, and then IDE drives, first to fully support Ultra ATA/33/66 and Ultra ATA/100 drives, and the first to develop a RAID 0,1 card for Ultra ATA drives.

What is Promise Array Management Utility?

Promise Array Management (PAM) utility is Promise Technology's array and system monitoring utility. With PAM, you can monitor your arrayed hard drives, rebuild arrays, and check the operation of server-level components (fans, etc.). There are three basic software components to PAM: the Message Server, the Message Agent, and the Remote Monitoring Utility.

Before moving on to the actual installation process, we will describe where the PAM components should be installed in a typical network, what hardware they should be associated with, and what function each component performs.

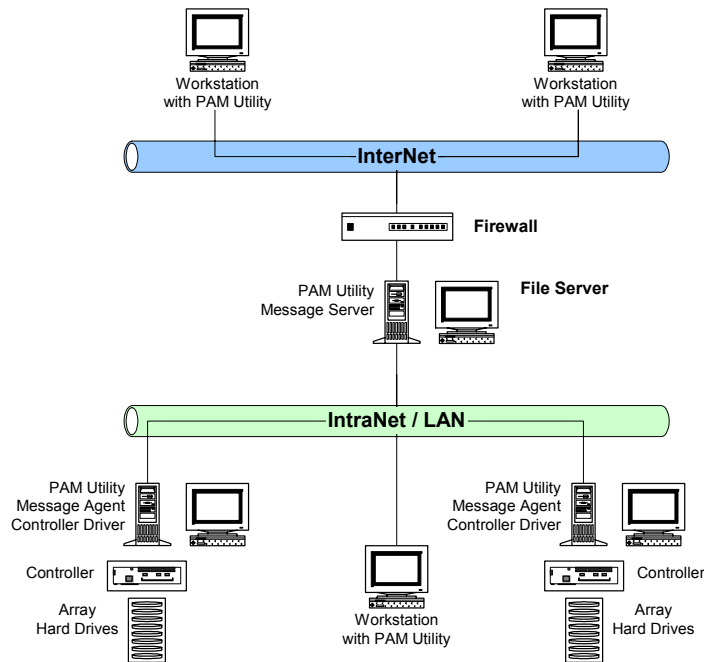

Figure 1 Typical PAM Component Installation

A typical installation of the PAM software components on a network might look like Figure 1 on page 1. The major elements of this network are (from top to bottom):

- Remote Monitoring Stations (via Internet)
- Main Network File Server (with direct Internet access via a Firewall)
- Internal RAID stations (connected via Intranet/LAN)
- Internal Monitoring Station

As shown, different components of PAM are installed on each of the network elements.

- (1) **PAM Monitoring Utility** - The PAM Monitoring Utility (the GUI that you will be using) may be installed on any system element with a TCP/IP connection where you want to perform monitoring. As shown in Figure 1, the PAM utility is installed on the main File Server, on both RAID stations, on two remote systems over the Internet, and on one internal system.

NOTE: For security reasons, array maintenance features can only be performed at the actual server location of a RAID and are unavailable at all other consoles.

- (2) **Message Server** - The Message Server software component serves as the main link between all of the PAM compatible arrays residing on the network, the internal Intranet/LAN (via TCP/IP protocols), and remote monitoring stations communicating via the Internet. For remote Internet monitoring, the Message Server component must be installed on a machine with a unique IP address that is visible to the Internet (as in our example). From its central communications position, the Message Server software interfaces with all of the PAM compatible arrays located on the LAN and allows all system elements (with the GUI installed) to see those arrays. The File Server where the Message Server software is installed may or may not house a PAM compatible array, such as the FastTrak or SuperTrak RAID controllers. In our example on Figure 1, it does not.
- (3) **Message Agent** - The Message Agent software component must be installed on each file server that will house a PAM compatible array. The Message Agent communicates with both the Message Server and the PAM compatible controller.

Key Features

The following are key features of the Promise Array Management (PAM) utility RAID system:

System Requirements

Windows NT 4.0®/Windows 2000® (or later) on workstations; Windows NT 4.0/Windows 2000 or Windows 95® (or later) on remote workstations. A PAM compatible array must be installed on a Windows NT or Windows 2000.

Operating System Support

While PAM is designed to specifically support Windows NT 4.0/2000 and later, users may employ other operating systems to access many of its operational features. What follows is a brief description of the different support levels available for each operating system:

Windows NT/Windows2000

Windows NT 4.0 or Windows 2000 is recommended to take full advantage of all the features of the Promise Array Management Utility. The PAM utility installed on the file server or PAM compatible RAID will only function on a Windows NT/Windows 2000 system.

Windows 95/98/Me

The PAM utility may be implemented on a Windows 95/Windows 98 station or remote terminal to remotely monitor PAM compatible arrays that exist on a network.

Promise Array Management™ Setup

PAM Installation

The installation setup process installs the various PAM components needed for remotely monitoring PAM compatible arrays. The installation setup process may follow either an automated process, by selecting “SuperTrak” or “FastTrak” at the Installation Wizard screen (see Figure 2) or by selecting “Custom”. Regardless of your selection, the Installation Wizard follows the same general path with the only difference being that with the “Custom” process you will need to manually select the various PAM components that will be installed.

Most installation setups are completed by selecting either “SuperTrak” or “FastTrak”, proceed to PAM Installation on page 5 if you are using this method. Otherwise you need to familiarize yourself with following Custom Installation process before continuing.

Custom Installation

A custom installation allows you to choose the necessary software components to install on your workstation. The following installation scenarios detail separate software installation model and should meant to help you manage a custom installation.

NOTE: *All systems with the RAID controller will require the Message Agent software. Additionally, the component installations that follow require TCP/IP to be already properly installed on the server system.*

NOTE: *While you may install multiple systems with the Message Server software, Promise Technology recommends against it because the same arrays will be visible from every instance of the Promise Message Server, thus causing confusion.*

To access a PAM compatible system locally

- Install the Message Server and Monitoring Utility onto this system.

To access a PAM compatible system remotely across a LAN

- Install the Message Server software in one or more systems on the LAN. The system(s) chosen for the Message Server may also include a PAM compatible RAID, an independent station on the LAN, or act as a network server for the LAN. All Message Agents connected on this LAN will be visible from each instance of the Message Server.
- Install the PAM Monitoring Utility software on to each LAN station from which you wish to monitor the PAM compatible RAID(s). When you begin PAM, you will need to perform “Creating a New Message Server” (see page 10) for each Message Server installed in step 1 that you want to monitor.

To access a PAM compatible system remotely on a WAN

- If you have not done so already, install a Promise Message Server on a system on the LAN. The system chosen for the Promise Message Server installation may house a PAM compatible RAID, be an independent station on the LAN, or house a network server for the LAN. For remote Internet monitoring, the Message Server component must be installed on a machine with a unique IP address that is visible to the Internet. All Message Agents connected on this LAN will be visible for each instance of the Promise Message Server.
- Install the PAM Monitoring utility on to each remote station where the PAM compatible system will be monitored. When you begin PAM, you will need to add a

new Message Server for the Promise server installed in Step 1 that you wish to access (see Creating a New Message Server on page 22).

- If the WAN that the Monitoring utility will be connected has any firewall protection measures, you must open the IP address for the system (or systems) containing the Promise Message Server software in order to connect to them over Internet/WAN. TCP/IP port number 710 and 711 are used by the Message Agent to accept in-bound connections.

PAM Installation

This section outlines the installation procedure for a component of the PAM software package. See the Custom Installation, outlined on page 4, to determine which components to install.

NOTE: If you are re-installing PAM, you must first stop the services for the Message Server and Message Agent for installation to work.

For each component to be installed, do the following:

- (1) Insert the PAM Install Diskette Number 1 into the floppy drive.
- (2) From Windows, go to the "Start" button, and click on "Run" from the "Start" menu.
- (3) Type in:
A:\PAMSetup.exe
- (4) The main PAM component installation menu will come up as seen below.



Figure 2 PAM Component Installation Menu

- (5) Select SuperTrak, FastTrak or Custom installation by clicking it. Then click the "Next" button to display the installation you have chosen.
- (6) When you see the "Setup Needs the Next Disk" pop-up window (shown in Figure 3 below), insert the PAM install diskette number 2 in the floppy drive. Click on the "OK" button when it is ready. (You may use the "Browse" button if your installation software resides anywhere other than the floppy diskette to choose the correct source location.)



Figure 3 Setup Needs the Next Disk Pop-Up Window

- (7) Review the installation settings. If the settings are correct, click "Finish" and proceed to the license agreement window; otherwise click "Back" and return to Step 4.
- (8) You must click "Yes" and agree to the licensing terms to use the PAM utility. Clicking "No" will exit the PAM setup.
- (9) When the "Choose Destination Location" window (see Figure 4 below) comes up, choose a directory to install this component.
- (10) Click "Browse" to select a Destination folder other than the folder suggested by default. Click the "Next" button to accept the location selected.

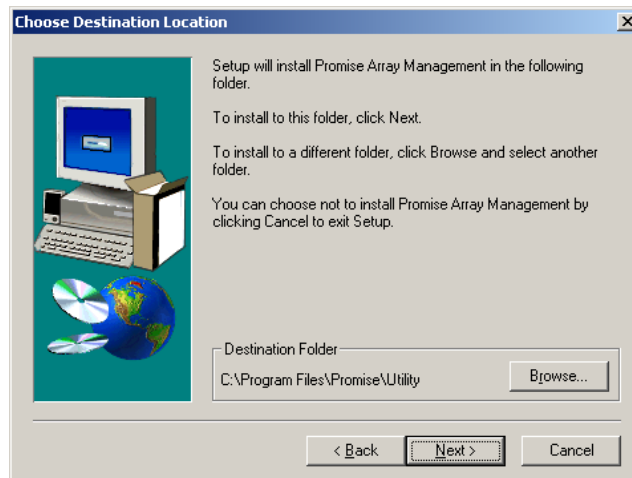

Figure 4 Choose Destination Location Window

- (11) The "Select Program Folder" window comes up next (shown in Figure 5 below). Choose a Start menu folder to list this item under by entering a folder name, and selecting a parent folder from the list under which this new folder's contents will reside. Click the "Next" button to proceed.

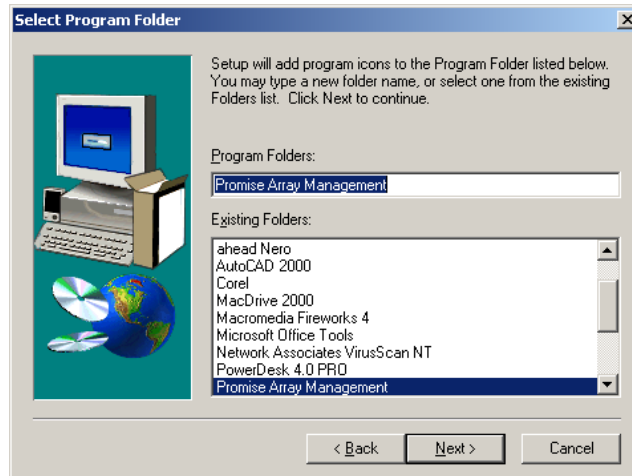

Figure 5 Select Program Folder Window

- (12) The “Start Copying Files” window will then be displayed (see Figure 6 below). Verify that the proper component(s), destination folder, and program folder you selected for installation are correct, then click on the “Next” button to proceed, otherwise, click the “Back” button to go back and make changes.

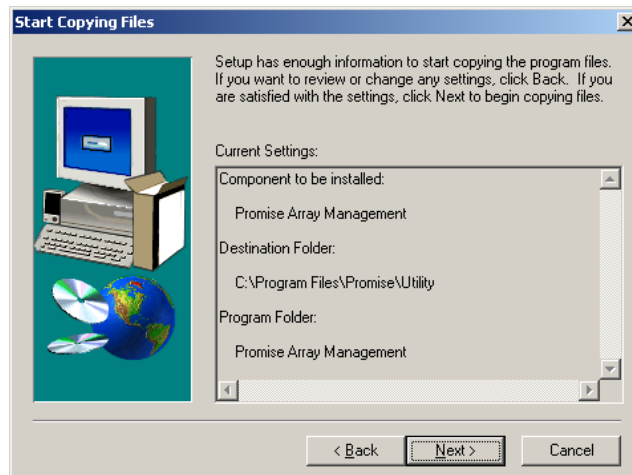

Figure 6 Start Copying Files Window

- (13) At the “Install Message for Monitoring Utility,” shown in Figure 7, enter an appropriate name for the “Server Description” and complete the “IP address” information and then click “Next”. Click “Next” if the information is already correct. Contact your system administrator if you do not know the IP address.

Note: When asked for an IP address during the installation or log process, always use the IP address for the system that contains the remote PAM compatible array that you wish to

monitor. If you are installing PAM on the same workstation that contains a PAM compatible array then use the default IP address (127.0.0.1).

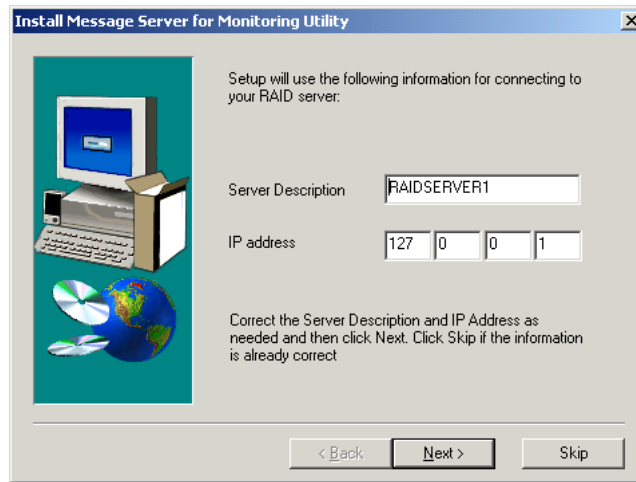

Figure 7 Install Message Server for Monitoring Utility Window

- (14) Complete the “Add User Account for Administration” information, see Figure 8. You may accept the default name or you may enter a new name in the “Name” field. Enter a password in the “Password” field and enter the same password in the “Confirm Password” field. Click “Next” after you have completed all of the fields.



Figure 8 Add User Account for Administration

- (15) Select “View readme.txt now” to read the latest product release information and select “launch Promise Array Management now” if you wish to run utility directly from setup. Click on the “Finish” button to complete the install process.

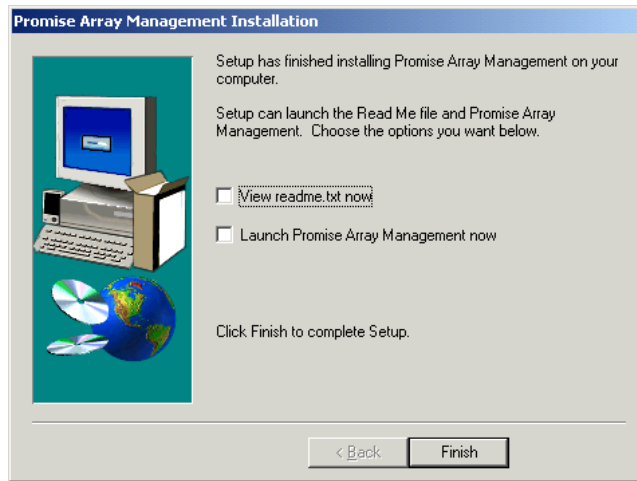

Figure 9 Setup Finished

PAM Administration

Once installation is complete, you may begin using the PAM utility. However, there are still a few things that need to be configured before your PAM installation and administration are complete. This section will outline the tasks necessary to complete PAM Administration.

After you have reviewed and implemented each task below, your PAM installation will be complete.

Creating Message Servers and Agents

Once the Message Server has been connected successfully, double-click on the Message Server icon to expand the hierarchical tree to show all attached Message Agents. Log into an attached Message Agent for access to the particular RAID system under the Agent's control.

Adding/Deleting New Users

If additional users require access to a Message Agent, the system administrator must create a "new user" under the Message Agent. Each user *may* be given access to various levels of control by an administrator.

"User / Administrator" may create/delete other user accounts. "Array Administration Rights" and "Adapter Maintenance Rights" boxes allow access to specific functions of the system.

NOTE: *Don't forget to set a password for any user who has anything more than viewing privileges on a secure network.*

Setting Up A New Array

Setting up an array is considered a simple task. Consideration should be given as to the type and configuration of the array.

Array Administration

Array administration is the ability to create, view, modify and delete arrays. The ability to view the status of an array through the utility allows identification of problems that may require user intervention to prevent the array from going down or to restore fault tolerance.

NOTE: For security reasons, actual maintenance of the array (deleting, rebuilding, creating, etc.) may be performed only from the system housing the array. PAM grays out the maintenance functions for remote monitoring stations.

The I/O information (IOP or Controller) subpanes (see page 43) of PAM allow you to see that all drives are functioning correctly. If any drive has failed, PAM will indicate which drive(s) has failed. You also can see the array status to determine if it is functioning, or if it requires critical attention, or if it has begun an automatic rebuild, etc. The array page allows modification of the cache settings for fine-tuning your server's performance. The enclosure pane allows you to verify that the drives are operating within temperature specification, and that the enclosure cooling fans are operational.

NOTE: *Never delete an array unless you have backed up all data that is needed on the array. It may be possible to restore access to an array after the deletion by re-creating the array exactly as it was defined previously. Though the product allows for this procedure, Promise Technology does not recommend it.*

Setting Up Email Notification

PAM allows the administrator or user to check on array status at anytime. You can also set up e-mail notification so that PAM will notify you of any problems via e-mail messaging services. The notification feature is recommended for any type of array that is to be accessible over a network. The administrator can add or remove events from the e-mail alert notification as desired.

Identifying Problems

There are a variety of problems that can be detected by PAM, allowing you to possibly prevent a system crash or data loss due to a hardware problem. The software can determine if an array member has failed, show whether the housing temperature is within operational parameters, or identify a problem with the housing cooling fans. Refer to the Troubleshooting Guide for a recommended course of action if you experience any failures.

PAM Quick Reference

The following section is a listing of initial steps necessary to complete each task during administration of a RAID server system using the PAM utility. These tasks are not listed in any particular order, nor are they intended to be a complete, step-by-step guide to setting up the software successfully. Please refer to PAM Administration on page 9 for details on what tasks to execute for basic operations.

To Create a New Message Server



- (1) Right-click on the "MyConsole" icon  located in the Tree View area of the PAM main menu (or left-click "My Console" from the pull-down selections at the top of the main menu).
- (2) Click on "New," then "Server" in the expanded pop-up menu. This adds a new RAIDSERVERx icon (where x is a sequential number).

- (3) Click on the new "RAIDSERVERx" icon in the message server Information View, enter "Label," and "IP Address" information.
- (4) Click the "Confirm" button. Once a new Message Server is created, it will create a Message Agent icon  automatically.

Accessing Message Agent

- (1) While in the TreeView, right-click on the Message Agent  and select "Login."
- (2) Enter the "Username" and "Password" information.
- (3) Click "OK" to submit the password and access the Message Agent.

Creating a New User



- (1) Log into the Message Agent for which you would like to add a new user.
- (2) Right-click the "Users" icon  (by expanding the Tree View of the Message Agent). Then left-click on "New" and select "User" from the pop-up selection.
- (3) A "New User" icon  will appear. Click on it to view the user Information View.
- (4) Modify all the user information according to the desired access level for the new user.
- (5) If the user has any level of administrative control, and the server is connected to a WAN, make sure to set a password.
- (6) Click the "Commit" button to update the user information.

Deleting an Existing User

- (1) Select the icon  representing the user you wish to delete.
- (2) Right-click the icon and select "Delete" from the pop-up menu.
- (3) Choose "Yes" if this is a user you wish to delete.

NOTE: PAM will not allow deletion of the last account with admin privileges. This protects the admin from being locked out of the system and having to re-install PAM.

Creating a New Array

- (1) Select the controller icon  on which you want to create an array.
- (2) Right-click the icon. Click "New" then select "Array" from the pop-up menu.
- (3) Enter the pertinent information in the "Name," "RAID Level" and "Block Size" fields. (Available RAID level selections are based on number of drives to be used; Block Size is selectable from a pull-down list or use the default 64K.)
- (4) A new array icon  will be created in the Tree View, titled with the text entered into the Name field.

- (5) Expand the channels that contain the free drive that you want to assign to the new array.
- (6) Drag and drop any unassigned drive icon  on top of the array icon that you have just created in order to add the drive to the array (unassigned drive icons do not have a red arrow in the upper left corner). Hard drive(s) will then be assigned to the array in the order that they are dragged on to the array icon.
- (7) If you incorrectly selected the wrong disk for the array at this time, simply highlight that disk in Tree View, right-click the mouse, and select "Delete" from the pop-up menu. The disk will be removed from this array.
- (8) Repeat step 6 until the array is completed.
- (9) Press the "Commit" button and reboot the Operating System for a new array.
- (10) You will be given the option to Enable Initialization and Enable Gigabyte Boundary.
Initialization: Once initialization is started it will zero out all drives.
Gigabyte Boundary: If you enable gigabyte boundary, this will round off the drive to gigabyte, such that 1 gigabyte equals 1000MB instead of 1024MB.

NOTE: For more information regarding the Initialization and Gigabyte Boundary options, refer to your Promise RAID controller manual.

Deleting an Existing Array

NOTE: *Deleting an array may result in the loss of all data contained on it. Be sure to back up any needed data before deletion.*

- (1) Right-click the icon of the array  you wish to delete.
- (2) Click "Delete" from the pop-up menu.
- (3) Click the "OK" button if this is an array you wish to delete. Reboot.

Setting Up E-mail Alert Notification

- (1) Double-click on the "Message Agent" icon  from where you want to receive email alert notifications. This will reveal the Message Agent main screen.
- (2) Check the "Email alert on error" box in the Information View (if it is not already checked).
- (3) Type in the SMTP server address for your mail server in the "SMTP server" field. Your network administrator will have this information if you do not know it.
- (4) Click the "Change" button next to the input field to update the PAM configuration for the SMTP server.
- (5) Next, set the email address for this machine in the "Email ID of Alert Sender" field. This address will show up in the "From" field of the e-mail alerts. Recipients of these messages may reply to this address if it is a valid address.
- (6) Click on the "Change" button next to the input field to update the PAM configuration for the Email ID.

Adding a User to the Current Recipients List

- (1) Double-click on the "Message Agent" icon . Add any new user(s) needed for email alert notification. This will open the Message Agent main screen. Find the Information View of the Message Agent screen.
- (2) If you have not already done so, set up email alert notification(s).
- (3) In the "Alert Recipients Email Address List," type in the email address(es) of the user you wish to receive email alert notification(s).
- (4) Click the "Add" button to add any users to the list.

Removing a User from the Current Recipients List

- (1) Double-click on the "Message Agent" icon  from which you wish to remove a user for email alert notification(s). This will open the Message Agent main screen. Find the Information View of the Message Agent screen.
- (2) Under the Current Recipients segment, select the email address in the scroll box that you wish to remove.
- (3) Click the "Remove" button or press the "Delete" key to remove the address from notification.

Adding/Removing Events to/from Email Alert Notification

- (1) Double-click on the “Message Agent” icon  to change the alert email notification events you wish to modify. This will open the Message Agent main screen. Find the Information View of the Message Agent screen.
- (2) Select the event you wish to modify from the “Event” column.
- (3) Right-click on the “Email” column and select “Yes” to have this event send out an email notification. Select “No” to remove the item as an alert event.
- (4) When you are finished making changes, left-click the “Change” button next to the event selection scroll box to update the PAM configuration for email alert notification.

NOTE: The “Report” column is used for event reporting to the utility. Events may be accessed by right-clicking the controller icon .

Using PAM

This section is an in-depth software functionality reference for the PAM RAID Manager. It contains step-by-step instructions on activating events, modifying values, and executing all major tasks.

Main Window

Upon starting PAM, the main window will be displayed.

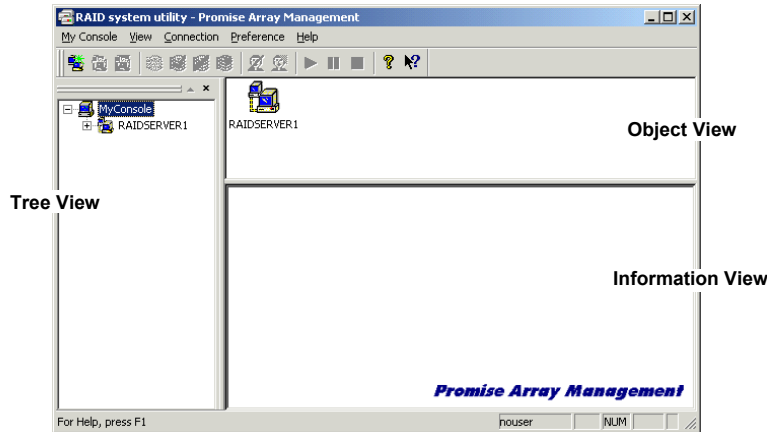

Figure 10 PAM Utility Main Window

Along the left side of the window is the "Tree View" that begins with "MyConsole" and can display the entire array system(s), down to individual hard drives within arrays and server-level components.

At the top right corner is the "Object View," which displays icons representing lower-level devices that appear below the highlighted device in the Tree View.

The PAM splash screen is displayed in the "Information View" of the window (the lower right hand section of the window).

Using Tree View

The Tree View can display every element of your RAID system. This menu behaves like the Tree View in Windows Explorer (Explorer shows logical drives and folders, etc... in a hierarchical menu structure). You may also choose to expand or collapse Tree View items, or hide/display the Tree View pane entirely.

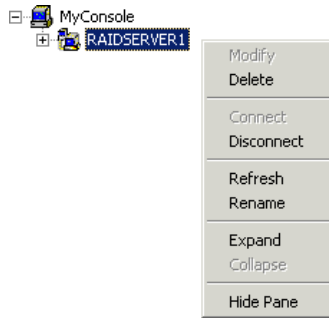

Figure 11 Using Tree View

Expanding/Collapsing Tree View Items

To open the items below a listed device, click once on the to expand the tree, to collapse it. Double-clicking an item will not only cause the tree to expand down, but will also add the sub-items as icons in the Object View. You may also right-click a listed device and select “Expand” or “Collapse” from the drop-down menu. (See Figure 11 above.)

Hiding/Displaying Tree View

You may hide or show the Tree View pane of the PAM Main interface at any time. Navigation can be performed via the Object View and/or pull-down menus. The hide/show function is accessed either by right-clicking any icon in the Tree View and selecting “Hide” or “Show.” The same function may be used with the pull-down menu with any icon highlighted in Tree View (see Figure 11 above).

Renaming Displayed Levels

You may rename the array and server names at the Tree View depending on their administration rights.

The renaming function is accessed either by right-clicking the appropriate icon in the Tree View and selecting “Rename” or by using the pull-down menu with the appropriate icon highlighted in Tree View.

Refreshing PAM Monitoring

Users may manually refresh PAM’s display of the server environment shown in Tree View at any time to immediately see system changes anywhere in the network. The default refresh rate is once every 10 seconds.

The refresh function is accessed either by right-clicking icons in the Tree View and selecting “Refresh” or by using the pull-down menu with the appropriate icon highlighted in Tree View. It can also be accessed using the [F5] function key.

Using Object View

The device icons generated by double-clicking the mouse in the Tree View will be displayed in this portion of the window. Double-clicking an icon in the Object View highlights the item corresponding to it in the Tree View and changes the Object View to include any items directly connected to the icon.



Figure 12 Using Object View

NOTE: Icons shown in this pane of the window which have a red “X” over them represent an error or failed device.

Using Information View

The lower right portion of the PAM main window is the Information View. The Information View contains different items (text boxes, list boxes, information fields and buttons), depending on which device is highlighted in the Tree View.

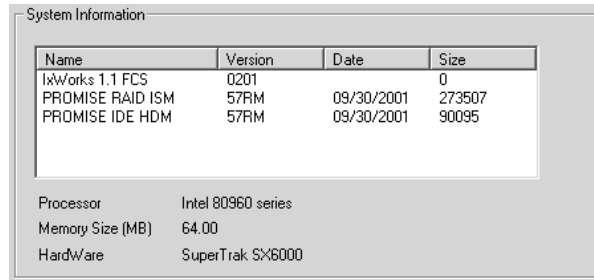

Figure 13 Using Information View

Using Status Bar



Figure 14 Using Status Bar

PAM’s status bar is no different than any other Windows program. The status bar is located just below the Main Window of PAM and provides status information of various administration functions such as (Ready, Rebuilding, etc...). The Status Bar can be displayed or hidden using the View pull-down menu.

PAM Pull-Down Menu/Toolbar

PAM uses a context-sensitive pull-down menu and optional toolbar with icons located at the top of the PAM Utility Main Menu. They provide access to all major PAM functions.

Using Pull-Down Menu Items

In addition to the options accessed from Tree View and the Information View, users may access the same functions from pull-down menu selections located at the top of the PAM utility Main menu. The options available are context-sensitive depending on which icon in the Tree View is highlighted (see example below). Certain functions that are unavailable will appear *grayed out*. Directions on implementing functions and options in this manual are based on the Tree View unless otherwise indicated.

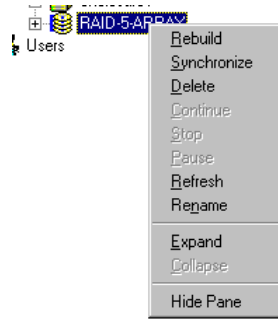

Figure 15 Array Pull-Down Menu

Using View Pull-Down Menu

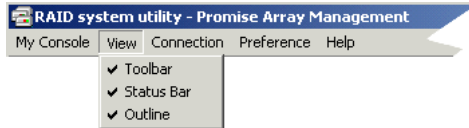

Figure 16 Using View Pull-Down Menu

By checking or unchecking items with the mouse, this pull-down menu selects or deselects the appearance of the Toolbar icons, Status Bar, and/or Tree View window.

Using Connection Pull-Down Menu

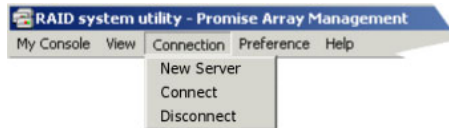

Figure 17 Using Connection Pull-Down Menu

The Connection pull-down screen is always available regardless of which icon is highlighted in the Tree View of the PAM utility. From here, a user may select from the following functions:

New Server

Creates a new server (see section Console Functions on page 22).

Connect

Establishes a connection with an already-created RAID server (see Connecting the Message Server on page 24).

Disconnect

Temporarily halts the connection with a RAID server (see Disconnecting a Message Server on page 24).

Using Preference Pull-Down Menu

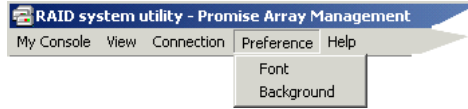

Figure 18 Using Preference Pull-Down Menu

The Preference pull-down menu allows users or administrators to change the way the PAM Main Window is displayed:

Font

Selecting Font allows you to select a different font and/or font color to display text

Background

Allows changing the color of the PAM View panes.

Using Help Pull-Down Menu

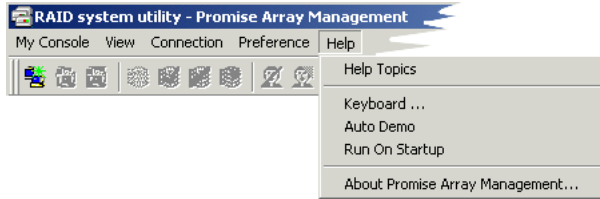

Figure 19 Using Help Pull-Down Menu

Activated from the pull-down menu, the Help menu allows users to access an online help index of how-to topics and functions, provides PAM version/build identification, and can activate a demonstration of all Main screens.

About Promise Array Management

This is a pop-up window that provides information about the version and build number of the PAM utility. Click the "OK" button to close.

Auto Demo

Provides a level-by-level automatic display of each screen in the PAM Main window, starting at the Console level in Tree View. You may also control the Auto Demo via the keyboard as shown in Figure 20.

Keyboard...

This is a pop-up window, shown in Figure 20 depicting a list of keyboard shortcuts.

Meaning	ShortCut
F12	Start/Stop Auto Demo
F10	Demo Next
F11	Demo Prev.
<Ctrl> Tab	Tab to Next Dialog
<Ctrl> + Arrow Keys	Scroll Property View
PgUp / PgDown	Scroll Property View

Figure 20 Keyboard Shortcuts

Using Help Topics

Activated from the pull-down menu or toolbar icon, online help offers information on functions and how-to items accessible from the PAM utility. There are two major areas, Contents and Find.

Contents

Lists PAM functions either by Interface Component (i.e. Tree View level item or Information View Menus) or by how-to actions (Starting Up, Managing Arrays, etc.).

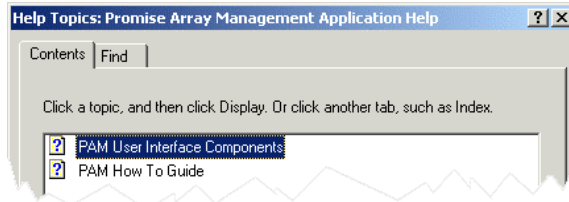

Figure 21 Using Help Contents Window

Find

Creates a comprehensive index based on each word and topic found in the Help file.

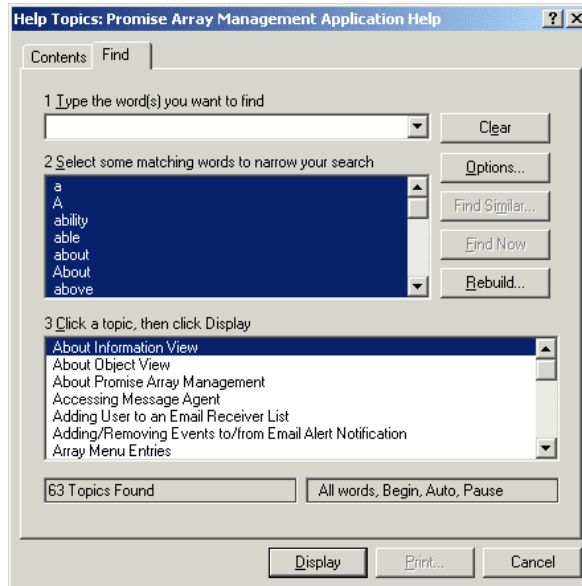





Figure 22 Using Help Find Window

Using PAM Toolbar



Figure 23 Toolbar Icons

Toolbar icons and their associated functions are available depending on which of the items in the Tree View is highlighted as described in the descriptions below.

- 
New Server: available when the Console icon is active. It allows the user to create a New Server on the RAID system. The user must have “User Account Rights” (see page 22 for details).
- 
Connect: available when a particular Server icon is active. It allows the user to recognize the server on the RAID system. The user must have “User Account Rights” (see page 24 for details).
- 
Disconnect: available when the Server icon is active. It allows the user to take the server offline from the RAID system. The user must have “User Account Rights”. Disconnect is the only proper way to shut down the RAID server in order to perform physical maintenance. This also logs off the server from being recognized by any other PAM monitoring utility online (see page 24 for details).
- 
Rebuild array: available when an Array icon for a RAID Level 1, 0+1, 3, or 5 is active. This begins the process of restoring data to a replaced drive from remaining drives in the array. The user must have “User Account Rights” (see page 48 for details).



Synchronize: available when an Array icon for a RAID 1, 0+1, 3, or 5 level array is active. This allows user to write data from primary mirrored drive(s) to secondary mirrored drive(s) to assure both have identical data as a maintenance procedure. The user must have “User Account Rights” (see page 51 for details).



Delete Array: available when an Array icon is active. This allows the user to delete the array from the RAID system. The user must have “User Account Rights” (see page 48 for details).



Create Array: available when a Message Agent icon is active. This allows user to create a New Array on the RAID system. The user must have “User Account Rights” (see page 39 for details).



Delete User: available when a User icon is active. This allows an administrator to delete the user from RAID monitoring/alert e-mail rights access. Only administrators may delete a user (see page 35 for details).



New User Account: available when a Message Agent icon is active. This allows the administrator to create and add a new user to the RAID system for monitoring/alert e-mail. The user must have “User Account Rights” (see page 27 for details).



Start/Continue: available when Array icon is active. This allows start/continuation of rebuild (see page 51 for details) or array synchronization process (see page 52 for details).



Pause: available when Array icon is active. This allows pausing of rebuild (see page 51 for details) or array synchronization process (see page 52 for details).



Stop: available when Array icon is active. This allows start/continuation of rebuild (see page 51 for details) or array synchronization process (see page 52 for details).



About: provides information on the version and build number of the PAM interface (see page 19 for details).



Help: loads PAM's Help contents and index (see page 19 for details).

Console Functions



The MyConsole icon in the PAM utility main screen represents the system from which you are monitoring your RAID system(s). Its icon appears at the top of the Tree View (see below). When this icon is highlighted, you may also access all Console functions from the pull-down menus at the top of the main menu or context-sensitive menus enabled by a right-click of the mouse.

Creating a New Message Server

- (1) Right-click on the “MyConsole” icon in the Tree View area of the PAM main menu (or left-click “MyConsole” from the pull-down selections at the top of the main menu).

- (2) Left-click on “New” in the console menu, then choose “Server” in the pop-up menu. This adds a new RAIDSERVERx icon (where x is a sequential number).

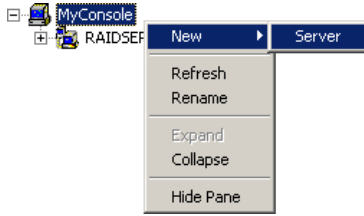

Figure 24 Creating New Message Server Pull-Downs

- (3) Click on the new “RAIDSERVERx” icon. In the Message Server Information View (see below), enter “Label” and “IP address” information. If you are not sure of the actual Server name, try just entering the IP address of the machine where the Message Server is installed. Enter “127-0-0-1” for a local machine connection.
- (4) Click the “Confirm” button.

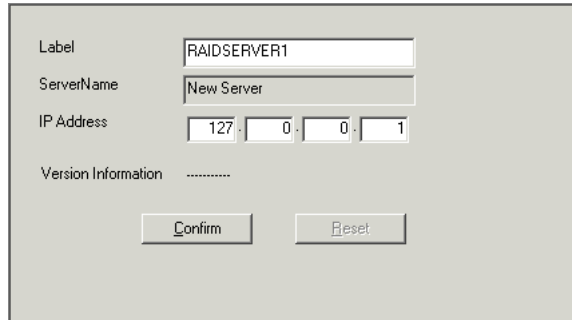

Figure 25 Labeling New Message Server

Viewing Console Object icons

Once a Message Server has been created, double-clicking on the Console icon will display the associated “Message Server” icon(s) in the Object View. These represent the message server(s) connected to the RAID console (see figure below). Clicking on the server icon(s) will display the Information View screen for the Message Server (see above).

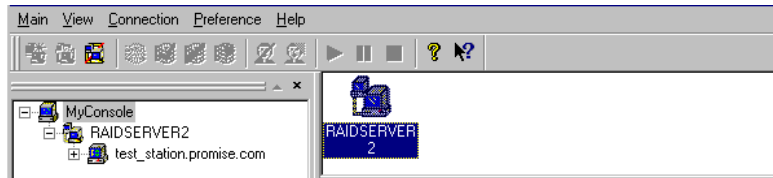

Figure 26 Console Object View

Message Server Functions



The Message Server icon in the PAM Tree View represents the server that acts as a *gateway* into a particular PAM compatible RAID system. The system may be composed of one server (the *gateway* server itself), or multiple servers. Message Servers may or may not have a RAID controller card and hard disk array installed. Once created, the Message Server will automatically recognize all associated Message Agents that exist on the network. Through the Message Server icon, users can delete a Message Server, and connect/disconnect the Message Server from system. When this icon is highlighted, you may also access all Message Server functions from the pull-down menus at the top of the main window.

Deleting a Message Server

NOTE: If the server's designated IP address is changed because of a physical move or system change, the Message Server must be deleted and a new Message Server created with the new IP address and Server name.

- (1) Right-click on the "Message Server" icon  in the Tree View area of the PAM main menu (or left-click "Server" from the pull-down selections at the top of the main menu with the "Server" icon highlighted in Tree View).
- (2) Left-click on "Delete" in the pull-down/pop-up menu.

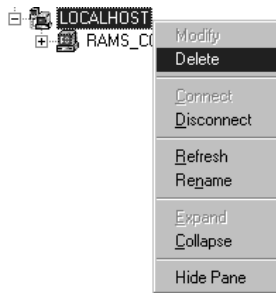

Figure 27 Deleting Message Server pull-down

- (3) Click the "OK" button. The Server name and icon will be removed from the PAM Main menu screen. This change will take effect on the next system reboot.

Disconnecting a Message Server

- (1) Right-click on the "Message Server" icon in the Tree View area of the PAM main menu (or left-click "Server" from the pull-down selections at the top of the main menu with the "Server" icon highlighted in Tree View).
- (2) Left-click on "Disconnect" in the pull-down/pop-up menu.

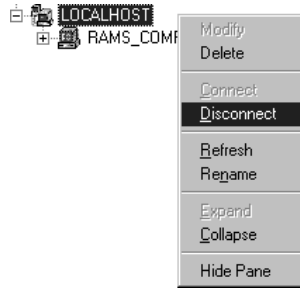

Figure 28 Disconnecting Message Server Pull-Down

NOTE: Disconnecting the Server from the RAID system prevents all PAM utilities from accessing information from the Server array(s). This allows server maintenance to be performed but does not require deleting and re-creating the Message Server data. This is also the only way to officially log out the RAID Server from the system. The utility will still see the Message Server, but in a disconnect status.

Connecting the Message Server

- (1) To connect a Message Server that has been taken offline, right-click on the "Message Server" icon in the Tree View area of the PAM main menu (see below) or left-click "Server" from the pull-down selections at the top of the main menu with the "Server" icon highlighted in Tree View.
- (2) Left-click on "Connect" in the pull-down/pop-up menu.

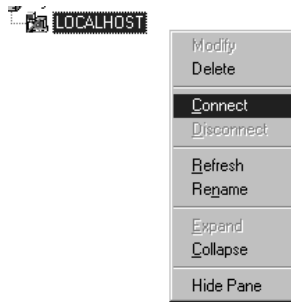



Figure 29 Connecting Message Server Pull-Down

Switching to another Server

- (1) To connect to a Message Server in a different location, make sure the Message Server icon is highlighted, then enter the "IP Address" and "Label" name of the desired server in the Information View (see Figure 25).
- (2) Click the "Confirm" button. You will now be connected to another RAID system location's Message Server and perform administrative functions (assuming you have password authority).

NOTE: You would switch Message Servers if the physical location of a Server or IP address has changed.

Viewing Message Server Object Icons

Double-clicking on the “Message Server” icon  will display the RAID system server icons connected to the highlighted message server within the Object View (see top of figure below). Clicking on the individual icons here reveals the Message Agent Information View.

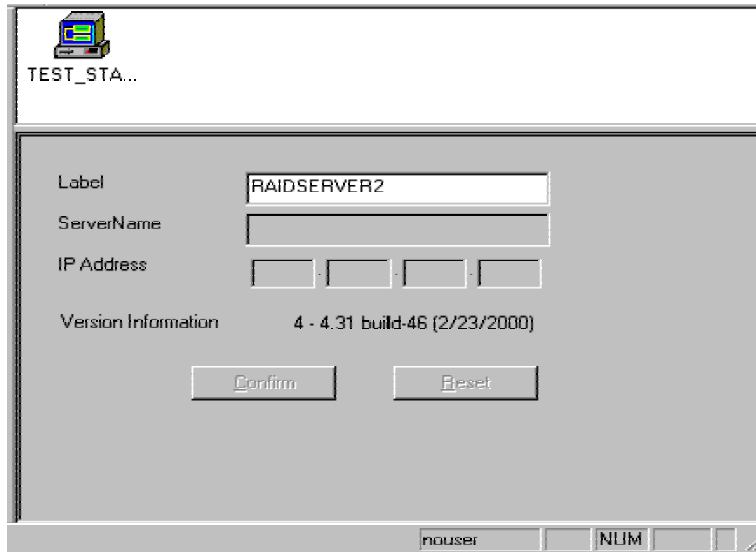

Figure 30 Message Server Information View

Viewing Message Server Information

In the Information View of the PAM window, several text boxes will appear. The fields for the Message Server Information view are defined as follows:

Label

In the “Label” text box, the name of the message server can be entered or modified, and will be displayed within the Tree View.

ServerName

The “ServerName” text box contains the internal operating system name of the message server currently highlighted. This entry is obtained from the server itself and cannot be modified.

IP Address

This series of four text boxes contains the IP address of the message server currently highlighted. The IP address field is grayed out so you cannot change the IP address.

Version Information

This field contains information pertaining to the build version of PAM currently operating. This field cannot be modified.

Confirm / Reset

These buttons relate to the text boxes titled Label, ServerName and IP Address. Selecting “Confirm” saves the entries in these fields after they have been modified. Selecting “Reset” clears the text boxes and allows the user to modify old information. These buttons are grayed-out unless you change the Label.

Message Agent Functions



The “Message Agent” icon(s) in the PAM utility main screen represent the RAID servers connected to the Message Server in a particular RAID system. There may be only one member in a network (the server itself), or there may be additional servers connected (remote systems). The Message Agent allows you to create new users, establish events for notification, create e-mail addresses for notification, and schedule array synchronization.

Accessing Message Agent

- (1) By clicking on any “Message Agent” icon in Tree View or Message Server Object View (if you are not already accessing the Agent), you will be prompted for password entry.

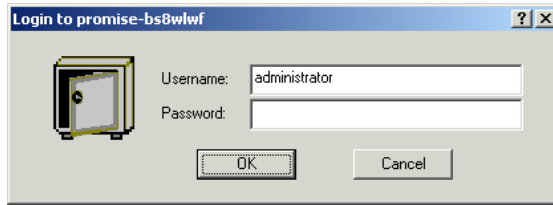

Figure 31 Setting Password Screen

- (2) Enter the account/password for this system to access the Agent and gain permission to the RAID system.
- (3) Click “OK” to submit the password and access the Message Agent.

NOTE: This Message Agent will remain accessible for the duration of the PAM session. The utility will NOT automatically log out. You must perform this manually.

Creating A New User

- (1) Log into the Message Agent for which you would like to add a New User.
- (2) Right-click the “Users” icon in the Tree View area of the PAM Main menu. Then left-click on “New” and select “User” from the pop-up selection (see below).

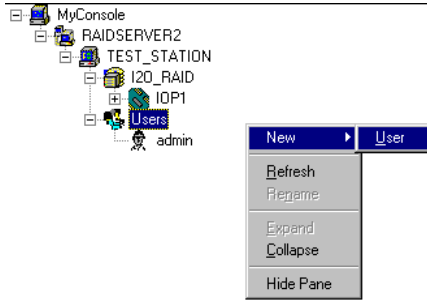

Figure 32 Creating New User screen

- (3) A "New User" icon will appear in the Tree View. Click on it to see the User Information View.
- (4) Modify all the user information according to the desired access level for the new user (see page 38 for more details on "User Account Rights")
- (5) If the user has any level of administrative control, and the server is connected to a WAN, make sure to set a password.
- (6) Click the "Commit" button to update the user information.

Setting Up E-mail Alert Notification

- (1) Double-click on the "Message Agent" icon from where you want to receive email alert notifications. This will reveal the Message Agent main screen. Find the Information View of the Message Agent screen similar to below.

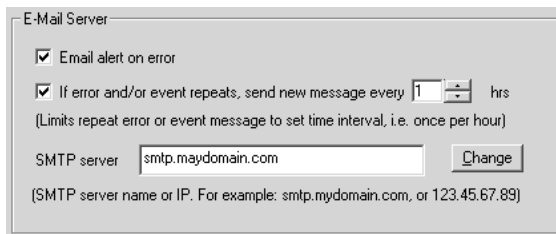

Figure 33 Setting E-mail Alert box

- (2) Check the "Email alert on error" box in the Information View (if it is not already checked).
- (3) Type in the SMTP server address for your mail server in the "SMTP server" field. Your network administrator will have this information if you do not know it.
- (4) Click the "Change" button next to the input field to update the PAM configuration for the SMTP server.
- (5) Next, set the email address for this machine in the "Email ID of Alert Sender" field. This address will show up in the "From" field of the e-mail alerts. Recipients of these messages may reply to this address if it is a valid address.

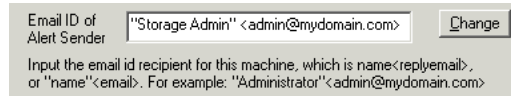

Figure 34 Setting Email ID window

- (6) Click on the “Change” button next to the input field to update the PAM configuration for the Email ID.

Adding a User to an Email Receiver List

- (1) Double-click on the “Message Agent” to which you wish to add a user for email alert notification. This will reveal the Message Agent main screen. Find the section of the Message Agent Information View screen similar to Figure 35.
- (2) If you have not done so already, set up email alert notification.

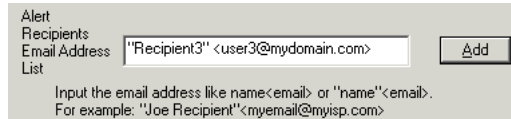

Figure 35 Setting Email Address Window

- (3) Under the “Alert Recipients Email Address List” segment of the Information View, type in the email address of the user you wish to receive email alert notification in the Email address field.
- (4) Click on the “Add” button to add this user to the list.

Removing a User From an Email Receiver List

- (1) Double-click on the “Message Agent” from which you wish to remove a user for email alert notification. This will reveal the Message Agent main screen. Find the Information View of the Message Agent screen similar to figure below.

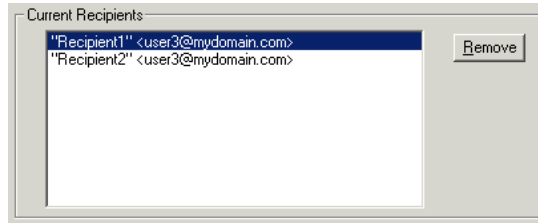

Figure 36 Removing User from E-mail Alert

- (2) In the “Current Recipients” segment, select the email address in the scroll box that you wish to remove.
- (3) Click on the “Remove” button to remove the address from notification.

Adding/Removing Events to/from Email Alert Notification

- (1) Double-click on the “Message Agent” icon whose alert email notification events you wish to modify. This will reveal the Message Agent main screen. Find the Information View of the Message Agent screen similar to Figure 37.

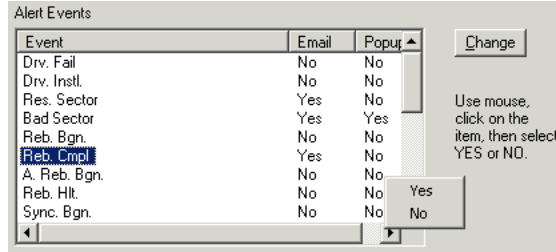

Figure 37 Adding/Removing Events for Email Alert

- (2) Select the event you wish to modify in the “Event” column.
- (3) Right-click on the “Email” column and select “Yes” to have this event send alert email notification. Otherwise, select “No” to remove it as an alert event.
- (4) When you are finished making changes, click the “Change” button next to the event selection scroll box to update the PAM configuration for email alert notification.

NOTE: The “Report” column is used for event reporting to the utility. Events may be accessed by right-clicking the IPOxor FTPx item and choosing “Read Events” from the menu.

Scheduling Array Synchronization

The Schedule Array Synchronization section (see below) allows the administrator to perform synchronization on a regularly scheduled basis (by minute, by hour, by day, by

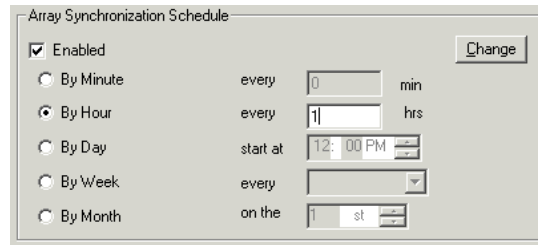

week, or by month).

Figure 38 Scheduling Array Synchronization

- (1) To schedule synchronization, check the “Enable” box.
- (2) Select the scheduling options appropriate to your timetable.
- (3) Click the “Change” button for the new schedule to take place.

NOTE: During Array Synchronization, users may continue to access the working array and perform normal PC functions. However, system performance will be slightly degraded and

the process will take longer. Scheduling allows synchronization to take place at off-peak time periods.

Viewing Message Agent Object icons

Double-clicking on a “Message Agent” icon will generate “I₂O_RAID” and “Users” icons in the Object View. Double-clicking the “I₂O_RAID” icon will reveal specific Agent information in the Information View (see next section). Double-clicking “Users” icon(s) will reveal User information.



Figure 39 Message Agent Console Icons

Message Agent Information View

The Message Agent Information View (see Figure 40 below) is a very long screen and requires the use of the scroll bar to view all of the contained fields. Descriptions of the sections within the Message Agent Information View are as follows:

NOTE: *To see all the fields in the Information View pane, minimize the Console View by placing the mouse cursor between the two panes so that the cursor changes to the window control cursor, hold down the left mouse button, and drag the boundary up until it disappears.*

Host name promise-bs8wvfw
 IP address 192.168.1.192

Enable NT system event log

E-Mail Server

Email alert on error

If error and/or event repeats, send new message every 1 hrs
 (Limits repeat error or event message to set time interval, i.e. once per hour)

SMTP server smtp.mydomain.com

(SMTP server name or IP. For example: smtp.mydomain.com, or 123.45.67.89)

E-Mail Sender and Recipients

Email ID of Alert Sender
 "Storage Admin" <admin@mydoma

(Input the email ID recipient for this machine, which is name<replyemail>, or "name"<email>. For example: "Administrator"<admin@mydomain.com>)

Alert Recipients Email Address List

(Input the email address like name<email> or "name"<email>. For example: "Joe Recipient"<myemail@mysp.com>)

Current Recipients

"Recipient1" <user3@mydo main.com
 "Recipient2" <user3@mydo main.com

Alert Events

Event	Email	Popup

(Use mouse. Click on the item, then select YES or NO.)

Array Synchronization Schedule

Enabled

By Minute every 5 min

By Hour every 1 hrs

By Day start at 12:00 PM

By Week every

By Month on the 1 st

Figure 40 Message Agent Information View

DNS Name, IP Address & Version Info

These three fields correspond to the “ServerName,” “IP Address,” and “Version information” fields in the Message Server Information box. They cannot be modified from here. (See Figure 30 on page 26.)

Enable NT System Event Log

By selecting this box you enable the application events recording to Windows NT/2000 Event Viewer. Events are recorded in AppEvent.evt.

Email Alert on Error

By checking this option, notification through email can be implemented when an error occurs on the currently highlighted RAID Message Agent. You will then need to enter the email address information of the RAID server in question in the two boxes directly below (“SMTP server” and “Email ID.”)

Repeat Error and Event Message Blocking

By selecting this box you block repeated error messages that occur within the selected time.

SMTP Server

Enter the SMTP server name or IP address of your mail server. Contact the System Administrator if you need this information. If you need to change information already entered, press the “Change” button next to the text box after typing in any new information.

Email ID or Alert Sender

Enter the email ID of the email location for the specific machine that is housing the RAID in this field. Email alerts will originate from this address. If you need to change information already entered, press the “Change” button next to the box after typing in any new information.

Alert Recipients Email Address List

Enter the email addresses of all individuals that need notification when an error occurs in a particular RAID station in this field. If you are monitoring multiple RAID stations, you must create a separate email list for each RAID station. After entering an email address, press the “Add” button to confirm the entry.

Current Recipients List

This area of the Information View contains all email addresses that an alert will be sent in the event of an error occurring on the RAID system. To add a new address, see Alert Recipients Email Address List above; to remove an address, highlight it and then press the “Remove” button.

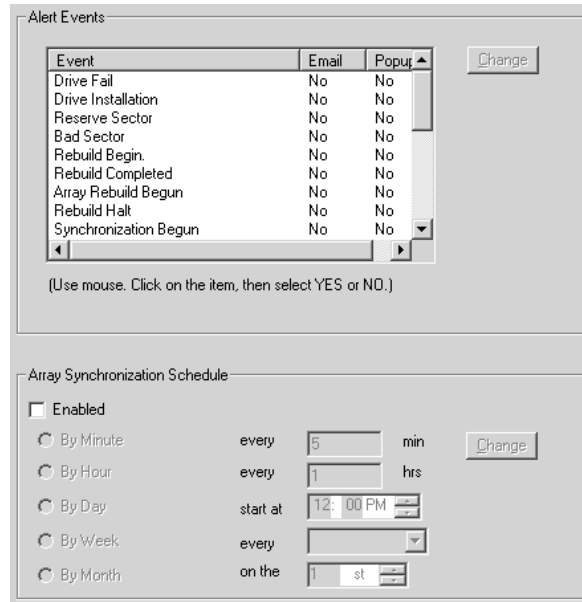

Figure 41 Alert Events & Schedule Synchronization Screen

Alert Events

This area (see above) allows you to choose which types of events will generate an email alert and/or report. To do this, highlight a particular event in the “Event” column, then click once in the same row on either the “Email” or “Popup” columns to toggle their active states between “Yes” and “No.” The email notification sends email to the alert recipients. Events checked in the “Popup” column will generate a Windows dialogue box when the checked events occur. The Event list may be

retrieved by right-clicking the controller  item. It may also be deleted from here.

Array Synchronization Schedule

Array synchronization is a periodic maintenance procedure for mirroring (RAID 1, 0+1, 3, and 5) arrays to maintain data consistency on all drives. In operation, array synchronization compares data on the drives for any differences. If there are differences detected, for RAID 1 and 0+1 arrays, data from the primary drive(s) is automatically copied to the secondary drive(s). For RAID 3 and 5 arrays, parity is recalculated. This assures that all mirrored drives will contain the exact information.

Click “Enable” to enable array synchronization, then choose an appropriated interval. Click the “Change” button to set the new parameters.

User Management Functions



The Users icon in the Tree View is a folder containing a list of users and administrators who are permitted access to a particular RAID system's status.

Creating A New User

- (1) Right-click the "Users" icon in the Tree View area of the PAM Main menu. Then left-click on "New" and select "User" from the pop-up selection.

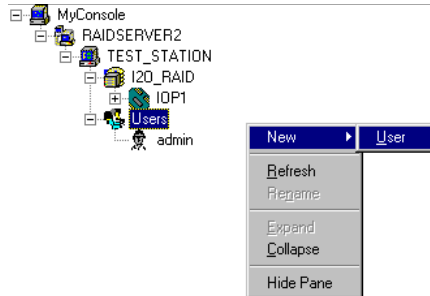

Figure 42 Creating New User Pull-Down

- (2) A "New User" icon will appear in the Tree View. Left-click on it to view the user Information View. (See Figure 45 on page 37.)
- (3) Modify all the user information according to the desired access level for the new user.
- (4) If the user has any level of administrative control, and the server is connected to a WAN, make sure to set a password.
- (5) Click the "Commit" button to update the user information.

Deleting an Existing User

- (1) Select the "User" icon in the Object View or Tree View representing the particular user you wish to delete.



Figure 43 Deleting User menu

- (2) Right-click the icon and select "Delete" from the pop-up menu.

- (3) Choose "OK" if this is a user you wish to delete.

NOTE: PAM will not allow deletion of the last account with admin privileges. This protects the admin from being locked out of the system and having to re-install PAM.

Changing Passwords

- (1) Double-click the administrator's "User" icon of the person whose password you want to change.
- (2) In the Information View, type the new password in the labeled box and confirm the password in the box below it.
- (3) Click "Commit" to enable the change or continue with other selections.

Assigning User Rights

- (1) Double-click the administrator's "User" icon of the person that you want to assign Array Rights.
- (2) In the Information View (see Figure 45), you may select from the following rights: "Create Array," "Delete Array," "Array Statistics," "Maintain Array," "Adapter Maintenance Rights," and "User Account Rights." Click the appropriate boxes to enable/disable these rights. See "Array Administration Rights" on page 37 for a more detailed explanation of these rights.
- (3) Click "Commit" to enable the change.

Viewing User/Admin Object icons

Double-clicking on the "Users" icon will generate "User" and "administrator" icons in the Object View (see figure below). Clicking on the individual "User" and "administrator" icons will reveal their access rights (see page 36).

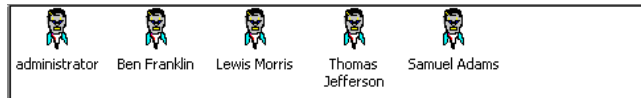

Figure 44 User icons in Object View



The "administrator" icon in the Tree View represents the configuration of a user who has "User Account Rights" on a particular RAID system. Double-clicking on the icon will display an administrator's "Information View," as shown in Figure 45 next page.

NOTE: No Object View will appear since this is the lowest level in this portion of the Tree View.

User Information View

The User Information View screen (see Figure 45) offers the admin/user the ability to assign passwords, array maintenance, adapter maintenance, and user account rights. What follows is a description of the fields in the Information View.

User Name

This text box contains the name of the administrator or user.

Password

The “Password” text box contains the (mask hidden) password of the administrator or user.

Confirm Password

The “Confirm Password” text box is used when changing the password. After entering the new password in the “Password” text box, enter it again in the “Confirm Password” text box to ensure accuracy.

Array Administration Rights

By checking these boxes, the user will be able to create, delete, and maintain arrays, and view array statistics.

NOTE: Array maintenance, creation, and deletion must be performed locally on the actual machine where the RAID controller card is physically located. Such functions are grayed out on a remote monitoring station.

The screenshot shows a web form with the following elements:

- User Name:** A text box containing "Ben Franklin".
- Password:** A text box with masked characters (dots).
- Confirm Password:** A text box with masked characters (dots).
- Array Administration Rights:** A section with four checked checkboxes: "Create Array", "Delete Array", "Array Statistics", and "Maintain Array".
- Adapter Maintenance Rights:** A section with one checked checkbox: "Enabled".
- User Account Rights:** A section with one checked checkbox: "Enabled".
- Buttons:** "Commit" and "Reset" buttons are located to the right of the Array Administration Rights section.

Figure 45 User Information View

Adapter Maintenance Rights

By checking the “Enabled” box, the user will be able to modify cache and performance tuning parameters for the RAID controller card.

SuperTrak

On the SuperTrak, maintenance rights enables the user to change the following parameters:

- Set the rebuild settings to “High Rebuild Priority”
- Enable battery backup support
- Set the “Automatic Flush Frequency” in seconds
- Enable S.M.A.R.T. Check

- Enable hard disk's write cache

FastTrak

On the FastTrak, maintenance rights enables the user to change the following parameters:

- Enable hard disk's write cache
- Enable S.M.A.R.T. Check
- Disable hot spare auto rebuild
- Adjust the rebuild rate
- Adjust the PCI bus utilization

User Account Rights

By checking the "Enabled" box, the user will be able to assign or modify user *rights* (such as *Array Administration* or *Adapter Maintenance rights*) of the user listed. This user will also be able to add or remove other users.

Commit / Reset

If, as an administrator or user, you need to change your password, change it as described above. If a mistake is made, press the "Reset" button to revert to previously saved values. After correctly typing the new password text, press the "Commit" button. The new password will then be operational.

I₂O RAID Functions



The I₂O RAID icon(s) in the Tree View represents the I₂O component installed on a Message Agent. Through here, you can identify model information and hardware/firmware versions.

Viewing I₂O RAID Object icons

Double-clicking on an I₂O RAID icon generates the controller (IOPx or FTPx) icon in the Object View (see below).



Figure 46 I₂O RAID Object View

Information View

In the Information View (see below), two fields are displayed: "Type" and "Version Information" which reflect the model number, name of the controller installed in the system, and version information concerning the hardware and firmware. No fields may be modified here.





Figure 47 I₂O RAID Information View

Controller (IOPx or FTPx) Functions



The controller (I/O Platform #x) icon(s) represent individual RAID controller cards which may be installed as part of a single or multiple RAID server system as seen by PAM. From here, users may create a new array, and can view information on specific servers and RAID controller cards. In addition, the user may choose to alter how often and what conditions of all RAID controller cards' onboard memory will flush their data during operation.

Creating a New Array

- (1) Select the controller  icon in the Tree View where you want to create an array.
- (2) Right-click the controller  icon. Click "New" then select "Array" from the pop-up menu as show in figure below.

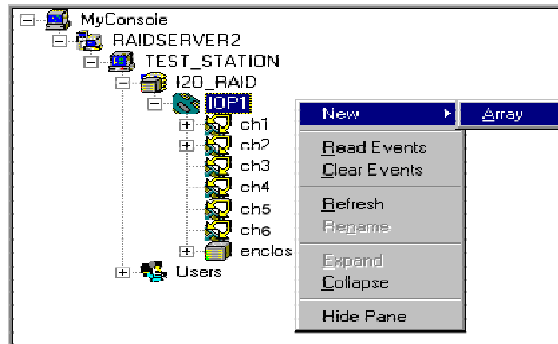

Figure 48 Creating New Array Pull-Down

- (1) Enter the pertinent information in the "Name," "RAID Level" and "Block Size" fields (see figure below).

Name	<input type="text" value="MY_RAID5_ARRAY"/>	<input type="button" value="Commit"/>
RAID level	<input type="text" value="RAID5(PARITY-DISTRIBUTED)"/>	
Block Size (KB)	<input type="text" value="64"/>	<input type="button" value="Reset"/>
Array Size	0 MB	
Array Status	functional	

Figure 49 Labeling New Array Window

- (2) The new array icon will be created in the Tree View, titled with the text entered into the "Name" field.
- (3) Drag and drop any unassigned drive icon within the Tree View area on top of the array icon that you have just created in order to add the drive to the array (unassigned drive icons do not have a red arrow in the upper left corner). Hard drive(s) will then be assigned to the array in the order that they are dragged on to the array icon.

- (4) If you have incorrectly selected a disk for this array, highlight that disk in Tree View, right-click mouse, and select Delete. The disk will be removed from this array.
- (5) Repeat step 3 until the array is completed.
- (6) Press the "Commit" button and reboot the Operating System to establish the new array.

Reading/Clearing Events from the RAID Memory Buffer

PAM allows the user to read alarm/maintenance events maintained by the RAID's onboard memory log, print a listing of these events, save the log to a file, or clear all events from memory. Clearing events should be performed on a periodic basis in order to reduce the length and size of the event buffer log.

- (1) To read events from the log, make sure the controller icon of the correct RAID controller card in Tree View is highlighted. Right-click on the Controller icon to view the drop-down menu shown in Figure 50.
- (2) Left-click "Read Events" or "Clear Event" or use the "Controller" pull-down menu at top.
- (3) Click "Read Events" to reveal the Event Viewer screen.

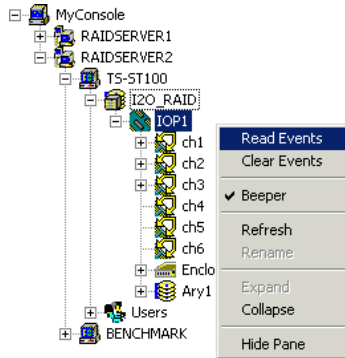

Figure 50 Read/Clear Events Pull-Down

Using The Event Viewer

After "Read Events" has been selected, the Event Viewer window appears (see below). The Event Viewer lists events according to type, date, status, and array status. The entire events log is not shown or accessed from the memory buffer since it can be quite large.

- (1) To sort the list according to category, click on the heading names.
- (2) To navigate through the events listing, use the "Next 10" buttons to go forward through events.
- (3) To capture all events contained in the buffer prior to printing, click on the "Get All" button.
- (4) To save the Events log to a file, click the "Save As" button. Input a filename and click "Close" button.
- (5) Press "Finish" button to close the Event Viewer and return to the PAM Main Menu.

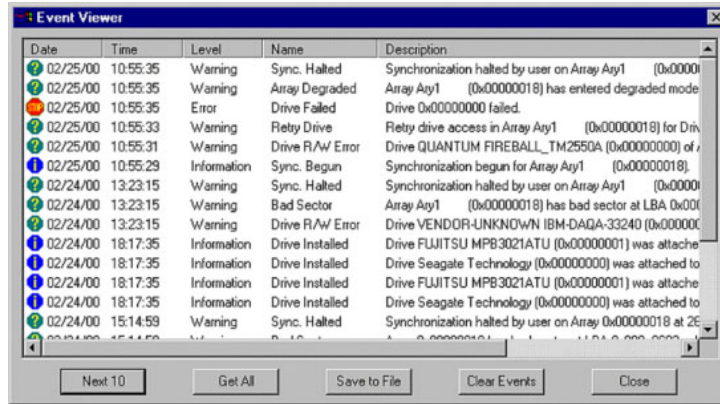

Figure 51 Events Viewer Screen

Viewing Controller (IOPx or FTPx) Object icons

Double-clicking on the controller icon  generates the components connected to the controller card – (from left) hard drive channels (first six icons below), enclosure components (7th icon below), and arrays (8th icon below) in Object View. Clicking on these icons will generate different information screens.



Figure 52 Controller Object View Icons

Controller Information View

The Information View displays the Controller Information View as seen in Figure 53. Depending on which Promise RAID controller you are using, there will be different options in this Window. The fields displayed in the Controller Information View are defined as follows:

System Information

The System Information section contains a list box that holds information concerning the controller's name, version number, timestamps, and size of file. Below are three text fields: "Processor," "Memory size" and "Hardware". They show the type of CPU running on the controller, the amount of memory present on the controller, and the type of interface chip on the controller respectively. Fields may not be modified.

System Information

Name	Version	Date	Size
iWorks 1.1 FCS	0201		0
PROMISE RAID ISM	47m	02/24/2000	272490
PROMISE IDE HDM	47m	03/13/2001	85223

Processor Intel 80960 series
 Memory Size (MB) 32.00
 HardWare SuperTrak SX6000

Rebuild Setting

High Rebuild Priority

Controller Setting

Battery Backup Support

Cache Setting

Automatic Flush Frequency (Seconds)

Disk Parameters

Enable S.M.A.R.T Check
 Enable Hard Disks' Write Cache

Figure 53 Controller Information View

SuperTrak Options

Rebuild Setting

Assigns the amount of importance that PAM gives to rebuilding an array in the background. When "High Rebuild Priority" is checked, PAM assigns most of SuperTrak's resources to the rebuild process at the expense of responding to ongoing read/write data requests by the operating system. When unchecked, PAM gives priority to ongoing read/write data requests by the operating system at the expense of the rebuild process and will typically result in longer rebuild times.

Controller Setting

Check this box if your SuperTrak has an optional battery backup unit (BBU). When BBU is on, SX6000 will always try to recover cached data from SDRAM when it is started, otherwise it will discard any unflushed data. BBU Support is useful in case of accidental power failure.

Cache Setting

Enter number to change the maximum number of seconds in which data in SuperTrak's cache memory is held before being written to disk. This option only applies when "Write-back cache" is enabled.

Setting Disk Parameters Option

Enable Hard Disks' Write Cache

Checkbox allows user to enable/disable write caching for hard drives that include this performance feature. PAM automatically recognizes such drives and enables the feature as the default setting. For drives that do not use write caching, this option is automatically grayed out.

Enable S.M.A.R.T. Check

Checkbox tells PAM to regularly monitor each drive to assure that drive failure prediction is functioning.

FastTrak Options

Setting Rebuild Options

Disable Hot Spare/Auto Rebuild

Turns off the use of a "hot" spare drive and automatic rebuilding if a mirrored array. The default is unchecked (or enable Hot Spare/Auto Rebuild).

Rebuild Rate

Assigns the amount of importance that FastTrak gives to mirroring data from one drive to another in the background. A "high" setting assigns most of FastTrak's resources to the rebuild process at the expense of responding to ongoing read/write data requests by the operating system. A "low" setting gives priority to ongoing read/write data requests by the operating system at the expense of the rebuild process and will typically result in longer rebuild times.

Setting PCI Bus Utilization Option

NOTE: *In most cases, a user does not need to change this setting since FastTrak's data handling rarely conflicts with another PCI device. However, certain brands of video capture cards can produce a "glitch" on playback of A/V files that may require adjusting the default setting devices (see Tips for Audio/Video Editing for more information).*

This section of the Options Window allows a user to change how much time the FastTrak holds on to the PCI bus to transfer data.

The default setting of "High" on the slider bar means FastTrak holds on to the PCI bus longer for data transfers to occur. A setting of "Less" reduces the time which FastTrak occupies on the PCI bus and frees that time for use by other PCI devices.

Once a bus setting has been selected, click the Apply button on the Options window to implement changes immediately.

Setting Disk Parameters Option

Enable Hard Disks' Write Cache

Checkbox allows user to enable/disable write caching for hard drives that include this performance feature. PAM automatically recognizes such drives and enables the feature as the default setting. For drives that do not use write caching, this option is automatically grayed out.

Enable S.M.A.R.T. Check

Checkbox tells PAM to regularly monitor each drive to assure that drive failure prediction is functioning.

Channel (chx) Functions



The chx icons represent particular drive channels (where x is a sequential number) on the RAID controller card.

Viewing Channel Object icons



Double-clicking on the icon displays the icons of the hard drives connected to the channel in the Object View. There is no Information View for Channel (chx). Double-click on the drive icons in the Object View to obtain a drive's Information View (see page 46).



Figure 54 Channel's Object View



Assigned drive icon indicates a drive that is already part of an existing array.



Unassigned drive icon indicates drive is not a part of an existing array. User may choose to leave drive to be used as a "hot" spare for a RAID 1,0+1, 3, or 5 level array. Unassigned drives may be assigned to create new arrays.

Hard Drive Functions



The hard drive icons represent hard drives connected to the RAID controller card. The icons are identified by the drive's make, model, status, size, DMA mode, and array configuration.

Hard Drive Information View

Since the hard drives are the last level in the PAM Tree View, the Object View will not contain any information. Double-clicking on a hard drive icon updates the Information View with information regarding the particular drive, as depicted below.

Disk Model	:	Maxtor 5T040H4
Disk Status	:	Functional
Disk Size	:	38.17 GB
Mode Setting	:	UDMA-5
Configuration	:	Assigned to an array
S.M.A.R.T Status	:	Disabled

Figure 55 Hard drive Information View

This Information View simply displays information about the drive. None of the fields may be modified. The field descriptions are as follows:

Disk Model

This field shows the make and model of the disk.

Disk Status

This field shows the disk's operational status.

Disk Size

This field reflects the disk's total physical capacity.

Mode Setting

This field identifies what transfer mode the disk is set for read/writes

Configuration

This field shows whether the drive is free (*hot spare*) or is assigned to an array.

S.M.A.R.T. Status

Indicates whether attached hard drive implements Self-Monitoring Analysis & Reporting Technology to predict drive failure.

Enclosure Functions



The Enclosure icon(s) represent the server-level monitoring capabilities of PAM. From this icon, users may choose to enable alerting alarms during rebuilding and synchronizing of arrays. In addition, they may monitor enclosure status if the user has mounted the hard drives inside optional FastSwap or SuperSwap *hot* swap boxes (one drive per box) manufactured by Promise. FastSwap permits monitoring fan and housing temperature status. SuperSwap allows monitoring fan, temperature, and power.

Enabling Rebuild/Synchronization Beeper

System administrators may wish to enable or disable an audible beeper alert that the RAID emits during rebuild of drives and synchronization of drives. The beeper warns the administrator that the system is in a degraded status during these processes and alerts the administrator when the process is complete.

- (1) Double-click the “Enclosure” icon in Tree View.
- (2) In the Information View (see Figure 57), check or uncheck the Rebuild/synchronization Beeper box.

Viewing Enclosure Object icons

Left-clicking on the “Enclosure” icon  in Tree View displays enclosure icons in the Object View and the enclosure status in the Information View.



Figure 56 Enclosure Object View

Enclosure Information View

The Information View shows a graphical representation of the FastSwap or SuperSwap enclosures, along with the monitored components (fan, temperature, or power), as shown below.

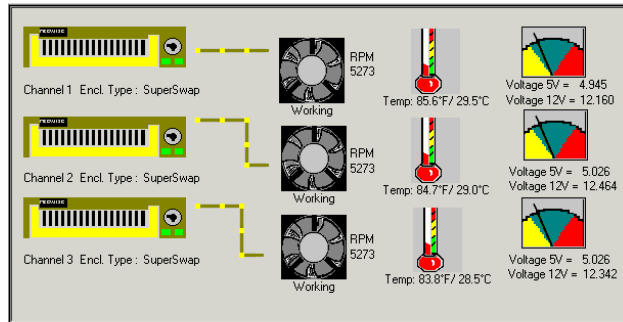

Figure 57 Enclosure Information View

The fan icons will display either a working fan, or a failed (error) fan. The temperature icon will display a working thermometer (with the internal temperature), or an error thermometer (if the temperature inside the enclosure exceeds 122° F). The power icons (not shown here) will display a working voltmeter (with voltages).

Array Functions



The “Array” icon in the Tree View represents the architecture of a particular array. From here, admin users can delete an existing array, rebuild data to a replacement disk, synchronize data on mirrored drives, rename the array, turn on/off read and write back cache, and view cache statistics.

Deleting an Existing Array

NOTE: *Deleting an array may result in the loss of all data contained on it. Be sure to back up any needed data before deletion.*

- (1) Right-click the Array icon of the array you wish to delete in Tree View (see figure below)

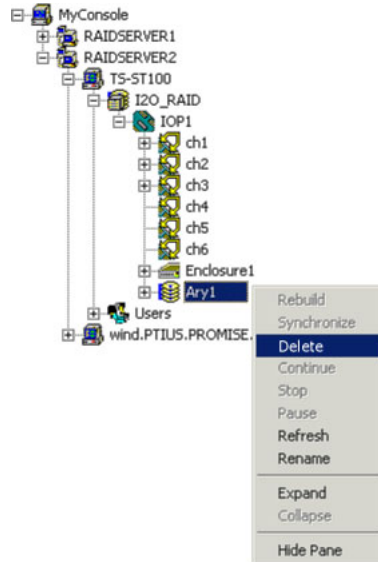

Figure 58 Deleting Array Pop-Up Menu

- (2) Click “Delete” from the pop-up menu.
- (3) Click the “OK” button if this is an array you wish to delete.
- (4) Reboot the system.

Rebuilding An Array

You will want to rebuild an array whenever a drive has failed and been removed from a RAID 1, 0+1, 3 or 5 array. For continuous operation, a replacement drive can be *hot* swapped while the attached system is operational.

NOTE: *In most cases, the rebuild process is initiated automatically -- either when a “hot” spare drive is available to the array or when a new hard drive is assigned to the array. The Rebuild Wizard screens (see page 49) will appear at this point.*

When rebuilding manually, data from the remaining working drive(s) can be reconstructed on to the target drive until data is restored. During rebuild, users may continue to access the working array and perform normal PC functions. However, system performance will be slightly degraded and the rebuild process will take longer.

NOTE: Remember that during an array rebuild, the array does NOT provide data redundancy. It is recommended that all rebuilds be carried to completion.

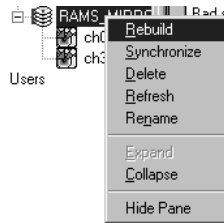

Figure 59 Array Pull-Down Menu

- (1) Identify the location of the target (failed) drive within the RAID housing based on the PAM GUI. It will show which array is *critical* and identify which drive has failed.
- (2) Physically remove the failed drive and replace with an identical drive or one with the same capacity or larger.
- (3) Click the Array icon of the array where the drive is attached and where you wish to perform rebuild within the Tree View.
- (4) Right-click the icon and choose “Rebuild” from the pop-up menu. This will open the Rebuild Wizard Step 1 screen (see Figure 60).

Using Rebuild Wizard

Step 1

- (1) Select the correct Target drive that will receive data (see below) Make sure you select the blank new or replacement drive. The unselected drive(s) will contain *good* data. This will be the remaining working drive(s) of an array, or a system drive containing existing data that you wish to mirror.

NOTE: Make absolutely sure and double-check which drive is which. If data exists on the target drive, it will be over-written.

- (2) Click the “Next” button to proceed to Step 2 or “Cancel” button to stop.



Figure 60 Rebuild Wizard Step 1

Step 2

- (1) Confirm the Target or *Rebuild* disk by drive identification.
- (2) Click "Finish" button to initiate physical Rebuild, click the "Back" button to review Step 1, or "Cancel" button to Stop (see figure below)



Figure 61 Rebuild Wizard Step 2

- (3) Once Array Rebuild has begun, you will be returned to the PAM window. A progress window will appear below the Array icons in the Object View (see below). A similar progress bar will also appear in Tree View.

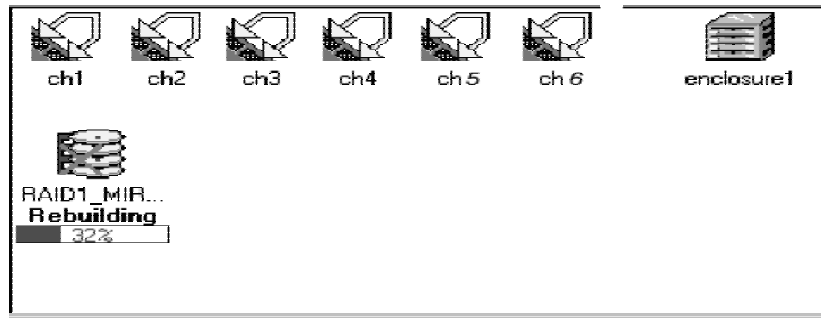

Figure 62 Array Rebuild Progress Bar

To Stop Rebuild

- (1) To halt the Rebuild process, right-click the “Array #” again.
- (2) The pull-down menu will appear showing the Stop option as shown below (see below).
- (3) Once Stop is selected, you will be asked to verify the Stop request.
- (4) Click “OK” to Stop or “Cancel” to continue Rebuild.

NOTE: You may also start/continue, pause, or stop the process using the Toolbar icons.

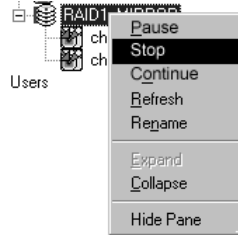

Figure 63 Stop Rebuild Pull-Down

Array Synchronization

Synchronization is a periodic maintenance procedure for Mirroring (RAID 1, 0+1, 3, and 5) arrays to maintain data consistency on all mirrored drives. In operation, array synchronization compares data on the mirrored drives for any differences. If there are differences detected, data from the primary drive(s) is automatically copied to the secondary drive(s). This assures that all mirrored drives will contain the exact information.

NOTE: Users may choose to schedule synchronization during unattended, off-peak hours (see page 34).

- (1) To manually synchronize drives from PAM, choose the icon of the mirrored Array in Tree View.
- (2) Right-click the “array” icon, and choose “Synchronize” from the pull-down menu (see Figure 64) or select “Array” from pull down menu at top and choose “Synchronize” from the pull-down menu.

- (3) This will initiate the process. Click “Yes.”
- (4) You will be returned to the main PAM screen. A progress bar will display at the bottom of the window.

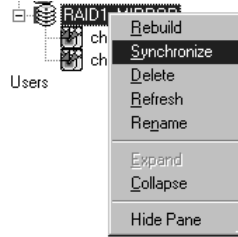

Figure 64 Array Synchronization Pull-Down

NOTE: During Array Synchronization, users may continue to access the working array and perform normal PC functions. However, system performance will be slightly degraded and the process will take longer.

Halting Synchronization

- (1) To halt the drive synchronization process, right-click the “Array #” again. The pull-down menu will appear showing the Stop option as shown below. You may also temporarily pause the synchronization process and then continue.
- (2) Once “Stop” is selected, you will be asked to verify “Cancel Synchronization?”.
- (3) Click “OK” to Stop or “Cancel” to continue Synchronization.

NOTE: You may also start/continue, pause, or stop the process using the Toolbar icons.

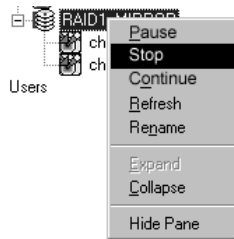

Figure 65 Halt Synchronization Pull-Down

Viewing Array Object icons

In the Object View, icons for the hard drives that are connected to the current array selected will appear. Clicking on these icons will display hard drive information (see page 45).

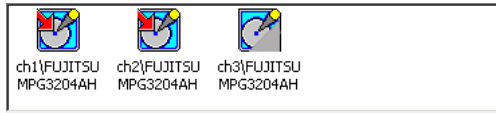
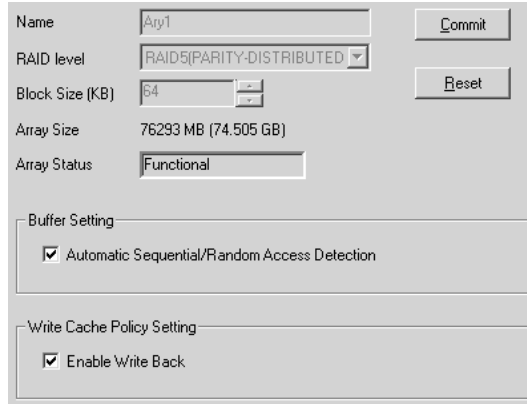

Figure 66 Array Object View

Information View

Left-click on the array icon in the Tree View to reveal the Information View pertinent to the



operation of that array, such as shown below.

Figure 67 Array Information View

The fields displayed on the previous page are defined as follows:

Name

This field contains the name of the array.

RAID Level

The “RAID level” text box contains the RAID level information of the array. Pressing on the arrow along on the right edge of the text box (operational only when creating a new array) displays a list of choices (RAID levels 0, 1, 0+1, 3, 5, or spanning).

Block Size (KB)

The Block Size reflects the stripe block size information used by this array. This value cannot be modified here.

Array Size

Describes the size of the array in megabytes.

Array Status

Indicates the current array status.

Buffer Setting

This allows you to enable or disable Automatic Sequential/Random Access Detection. When enabled, the read-ahead cache will determine if sequential or random I/O is occurring, and optimize itself based on the type I/O taking place. Under most circumstances, enabling this will provide better performance.

Turning On/Off Write Back Cache

Write-back cache affects system performance depending on server and application type. However, write-back cache data will be lost in the event of a system power outage or other event where the data has not yet been saved to disk. Turning off write-back caching will force the RAID to immediately save all writes to the drive.

To turn on/off write back caching from PAM, double-click the "Array" icon in Tree View. Left-click the arrow next to the Write Cache selection box and choose "Write Back." This will enable write and write back caching functions from RAID (see page 53).

Index

Administration		Creating	22
Assigning user rights	36	Deleting	24
Password protection	37	Disconnecting	24
Arrays		Switching Servers	25
Administration of	10	Networking	
Creating	11, 39	E-mail notification	10, 13, 28
Deleting	13, 48	LAN/WAN	4
Deleting drives	48	User administration	9
Fault tolerance in RAID 1	13, 48	Object View	16
Rebuild Wizard	49	PAM	1
Rebuilding	48	Adding users	9, 11, 27, 35
Synchronization	34, 51	Array info	48
Viewing status of	48	Array Synchronization	51
Beeper		Component installation	5
Enable/Disable	46	Creating arrays	11, 39
Block Size		Deleting arrays	13, 48
Viewing	53	Deleting users	9, 11, 35
Cache		E-mail notification	10, 13, 28
Controller info	54	Enclosure monitoring	46
User rights	37	Installation scenarios	4
Controller	2	Message Agent	11
Attached components	39	Message Server	10, 24
Cache policy	42	Setting password	37
Firmware info	42	System access	4
E-mail		Toolbar	21
Events list	14, 30	User administration	11, 35
Notification	10, 13, 28	User Administration	27
Receiver list	13, 29	Using PAM	15
Removing user	13, 29	Passwords	
Enclosure Management	46	Accessing Message Agent	27
Beeper functions	46	Changing User	36
Event Log		Setting	37
Clearing	41	Promise Array Management	1
Event Viewer	41	Pull-Down Menus	
Viewing	41	Connection	18
Hard drives		Help	19
Assignment of	46	Preference	19
Model info	45	View	18
Viewing	15, 45	Rebuild	
Hardware		Cancel	51
I2O support	38	Manual	48
Help Menu		Using Rebuild Wizard	49
Finding topics	20	Software Installation	
Viewing Autodemo	19	PAM	4
Viewing contents	20	Status Bar	17
I2O		Synchronization	
Version info	38	Arrays	51
Information View	17	Halting	52
Message Agent	2, 11	Scheduling	30, 34
Accessing	27	Tree View	
Message Server	2, 10	Collapsing	15
Connecting	25	Displaying	16

Expanding.....	15	Changing Passwords.....	36
Hiding.....	16	Creating.....	35
Refreshing display.....	16	Deleting.....	35
Renaming levels.....	16	Windows NT.....	3
Using.....	15	Services	
Troubleshooting.....	10	Message Agent.....	2, 11
Users		Message Server.....	2, 10
Assigning Rights.....	36		