

# AEROSTAT® HP-N-Ex Ionising Air Blower

User's Manual

UK



1180

BAS00ATEX2162X



II 2G Ex smb IIB T4 (Bar)



II 2G c T4 / T3 (Blower)



II 2G Ex e II T4 / T3 (Motor)

# CONTENTS

1. Introduction .....	3
2. Safety .....	3
3. Use and operation .....	3
4. Technical specifications .....	4
5. Installation .....	6
5.1. Checks .....	6
5.2. Installation of the HP-N-Ex Aerostat® .....	6
5.2.1. Summary .....	6
5.2.2. Mounting .....	6
5.2.3. Installation of the HP-N-Ex .....	6
5.3. Installation of the blower .....	6
5.3.1. Summary .....	6
5.3.2. Connecting the blower .....	7
5.3.3. Checking the direction of rotation .....	7
5.4. Connecting the P-Sh-N-Ex anti-static bar .....	7
6. Putting into use .....	7
7. Functional check .....	7
8. Maintenance .....	8
8.1. General maintenance .....	8
9. Faults .....	8
9.1. Anti-static bar .....	8
9.2. Blower .....	8
10. Repair .....	9
10.1. Replacing the anti-static bar .....	9
10.2. Replacing the air guide .....	9
11. Disposal .....	9
12. Spares .....	9

## 1. Introduction

Read this manual completely before you install and put this product into use.

This manual is intended as guideline for mounting, installing, and maintenance for skilled technical people. It should be read in combination with the additional manuals supplied separately for the P-Sh-N-Ex anti static bar and the radial fan (blower).

Follow the instructions set out in these manuals to ensure proper operation of the product and to be able to invoke guarantee.

The guarantee terms are stated in the General Conditions for the Sale and Delivery of Products and/or Performance of Activities by SIMCO (Nederland) B.V.

## 2. Safety

- The Simco-Ion HP-N-Ex Aerostat<sup>®</sup> is only intended for neutralizing electro statically charged parts and/or surfaces.
- When used in potentially explosion hazardous environments: only use the HP-N-Ex Aerostat<sup>®</sup> when the zone classification allows to use equipment as classified through the marking on the 3 labels on the H-P-N-Ex (classification on page 1 only for reference). Check the conditions for safe use in the ATEX certificate(s).
- Electrical installation shall be performed by a skilled electrical engineer.
- Make sure that the equipment is properly earthed.  
Earthing is needed to ensure proper operation and to avoid electrical shocks upon contact.
- No changes, adjustments, etc. are allowed. When changes, or no original parts have been used for repairs CE approval and Ex classification for the equipment will be withdrawn and the equipment will no longer be under guarantee.

## 3. Use and operation

The Simco-Ion HP-N-Ex Aerostat<sup>®</sup> is used to neutralize electro statically charged products and/or surfaces, also at longer distances (1.5 m max.). The ionizing air blower consists of a motor, a radial fan and an anti-static bar. The ambient air is drawn on one side and blown off along the anti-static bar. The power unit is integrated in the anti-static bar.

The blower produces an air flow which is rich on positive and negative ions.

When this air flow is pointed to an electro statically charged product or surface, electrons will be exchanged. This causes the product or material to be neutralized. The effective ionizing width is 380-580 mm.

The HP-N-Ex Aerostat<sup>®</sup> is suited for use in a potentially explosion hazardous environment, check if the zone where the equipment is going to be used complies with the equipment class.

## 4. Technical specifications

<b>Aerostat® HP-N-Ex</b>				
Voltage	230/400V	230/400V	254/440V	277/480V
Frequency	50Hz	60Hz	60Hz	60Hz
<b>Blower</b>				
Voltage / Current	Δ 230V AC 0.73A Y 400V AC 0.42A	Δ 230V AC 0.76A Y 400V AC 0.44A	Δ 254V AC 0.76A Y 440V AC 0.4A	Δ 277V AC 0.7A Y 480V AC 0.37A
Power out	90W	90W	90W	90W
Protection	IP55	IP55	IP55	IP55
Power cable	5m	5m	5m	5m
ATEX category	II 2 Gc T4/Ex e II T4	II 2Gc T3/Ex e II T3	II 2Gc T3/Ex e II T3	II 2Gc T3/Ex e II T3
ATEX Certificate	PTB02ATEX3114			
<b>Anti static bar</b>				
Voltage	400V AC	400V AC	440V AC	480V AC
Current	50mA	50mA	50mA	50mA
Frequency	50Hz	60Hz	60Hz	60Hz
Power cable	5m	5m	5m	5m
ATEX category	II 2 G Ex smb IIB T4			
ATEX Certificate	BAS00ATEX2162X			
HV signal OK	230V 10mA max			
<b>System HP-N-Ex</b>				
Working distance:	50 - 1500mm			
Working Width	380 mm – 580mm (See diagram)			
Weight:	12.5kg			
Noise level @ 1m	60dB(A)			
Protection	IP40			
Ambient temperature	0 - 40°C			
Air velocity	see diagram			

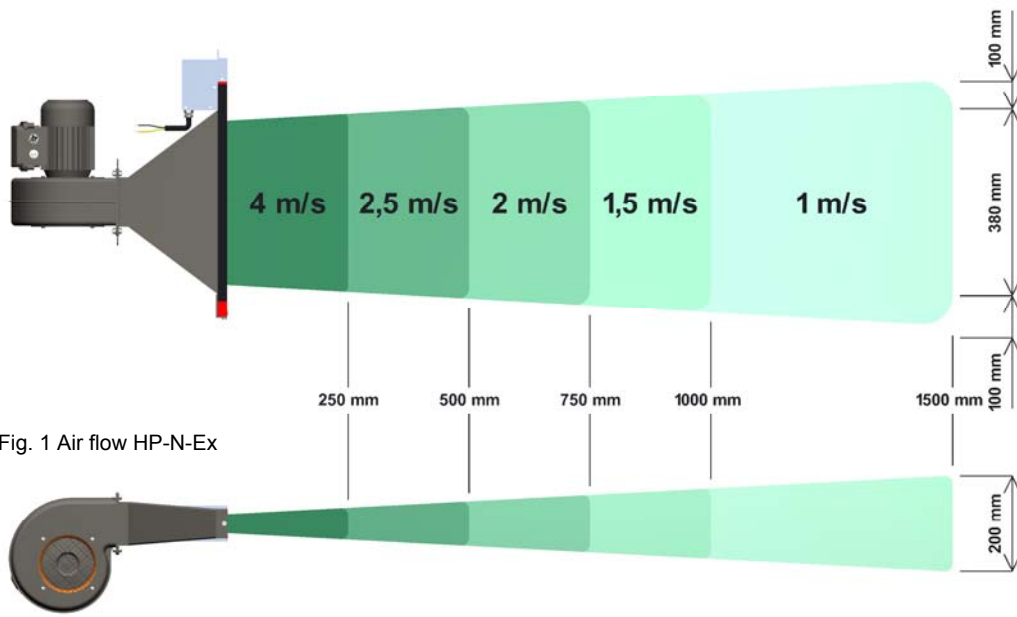

Fig. 1 Air flow HP-N-Ex

## 5. Installation

### 5.1. Checks

- Check if the equipment is undamaged and that you have received the correct version.
- Check if the data on the packing slip corresponds with the data shown on the product received.
- Check if the voltage shown on the rating plates corresponds with the (mains) voltage you are going to use.
- Check if the equipment may be used in the environment (Ex-zone).
- Check if there are requirements or instructions in the additional manuals from the attached ionizing bar, blower and motor.

*If you have any problems and/or in the case of ambiguity:  
Please contact Simco-Ion or your regional agent.*

### 5.2. Installation of the HP-N-Ex Aerostat®

#### 5.2.1. Summary

The air flow from the blower must be in a direction between perpendicular to, and at an angle of approx. 45° in relation to the material.

For maximum ionization the air flow must cover as large a surface as possible. The air flow direction must preferably be opposite to the material flow direction. In places where the material is going to be neutralized, it should have a free layer of air. The blower-neutralizing efficiency will drop dramatically when it blows along metal parts towards the area to be neutralized, as the ionizing function will be lost.

The effectiveness of the blower depends on the distance to the material, the air flow and the material speed. The correct position and airflow direction should be established by experiment.

#### 5.2.2. Mounting

Fit the HP-N-Ex, using the extra mounting holes between the blower and the air guide.

#### 5.2.3. Installation of the HP-N-Ex



#### **Warning:**

- **Electrical installation shall be carried out by a skilled electrical engineer.**
- **Earth the Aerostat properly: Earthing is required to ensure proper operation of the equipment and to avoid unpleasant electrical shocks upon contact.**

Earthing is provided through both line cords from blower and anti-static bar.

### 5.3. Installation of the blower

#### 5.3.1. Summary

Each blower motor must be fitted with a suitable protective motor switch. Adjust this switch to the rated motor current. The switch must be explosion proof or it must be mounted outside the explosion hazardous zone.

For additional instructions see the manual from the blower: Operating instructions for radial fans for use in potentially explosive atmospheres.

### 5.3.2. Connecting the blower

Connections shall be made in conformity with the applicable local regulations and instructions in this and the additional manual for the radial fan.

### 5.3.3. Checking the direction of rotation

- Switch the motor briefly on.
- Check the direction of rotation. It must correspond with the direction shown by the arrow.
- If necessary, change the direction of rotation by interchanging 2 phase wires in the connection.

### 5.4. Connecting the P-Sh-N-Ex anti-static bar

The anti-static bar must be connected separately (not through the blower). Check for the mains voltage on the marking from the P-Sh-N-Ex. The connecting line of the anti-static bar should contain a fuse. A 230V neon lamp can be fitted as a high-voltage present indicator. Also a relay can be fitted which triggers an alarm signal if the high voltage fails.

Check for the detailed instructions in the manual supplied with the P-Sh-N-Ex bar.

## 6. Putting into use

- Switch on the mains voltage from the anti-static bar.
- Switch on the mains voltage from the blower.

## 7. Functional check



### **Warning:**

- **In an explosion-hazardous zone only measuring instruments suited for this zone may be used.**

The neon lamp you fitted (outside the hazardous area) gives an indication of the high voltage. An electrostatic field meter must be used to measure the efficiency of the anti-static bar. Measure the charge on the material before and after it has passed the ionising blower. After passing the blower the charge should be neutralised.

## 8. Maintenance



### Warning:

- When carrying out work on the equipment: de-energise the equipment.
- Follow instructions belonging to the Ex zone you are working in.

### 8.1. General maintenance

- Keep the Aerostat® clean and dry.
- Clean fouled emitter points with a hard non-metallic brush.



### Attention:

- Do not damage the emitter points.

## 9. Faults

### 9.1. Anti-static bar

Problem	Cause	Remedy
No/poor ionization	Anti-static bar is fouled	Clean anti-static bar
	Emitter points are covered	Remove the cover
	Emitter points are damaged	Return anti static bar for repair
No high voltage on emitter points	No mains voltage on bar	Restore mains voltage
	Line-side fuse is defective	Replace the fuse
	Anti-static bar is defective	Return anti-static bar for repair

Table 1 Anti-static bar faults

### 9.2. Blower

Problem	Cause	Remedy
Fan does not operate	No mains voltage	Restore mains voltage
	Mains voltage on 2 phase wires only	Restore mains voltage on 3 <sup>rd</sup> phase wire
	Protective motor switch is off	Turn on/reset protective motor switch, check why it has switched off
Fan operates in wrong direction	Fan incorrectly connected	Interchange connection of 2 phase wires
Fan does not come up to speed	Mains voltage on 2 phase wires only	Restore mains voltage on 3 <sup>rd</sup> phase wire
No remedy helps		Return complete Aerostat

Table 2 Blower faults



## 10. Repair



### Warning:

- When carrying out work on equipment: de-energise the equipment.
- Repairs shall be made by a skilled electrical engineer.

### 10.1. Replacing the anti-static bar

1. Disconnect the anti-static bar.
2. Dismount the four screws in the profiles from the bar which connects the bar with the air guide.
3. Dismount the anti-static bar.
4. Mount a new anti-static bar by fitting the four screws through the profile to the air guide.
5. Route and connect the connection lead.

### 10.2. Replacing the air guide

1. Dismount and remove the Aerostat<sup>®</sup>.
2. Dismount and remove the anti-static bar.
3. Dismount and remove the air guide from the blower.
4. Mount a new air guide.
5. Fit the anti-static bar.
6. Fit the Aerostat<sup>®</sup>, using the extra mounting holes between the blower and the air guide.

For other repairs, Simco-Ion advises you to return the HP-N-Ex  
Request an RMA form by sending an e-mail to [service@simco-ion.nl](mailto:service@simco-ion.nl).  
Pack the HP-N-Ex properly and clearly state the reason for return.

## 11. Disposal

Adhere to the applicable local environmental and other rules when disposing of the equipment.

## 12. Spares

Item No.	Pos.	Description
1590010000	(1)	Anti-static bar P-SH-N-Ex, 400 V 50 Hz HP-N-Ex
1590010010	(1)	Anti-static bar P-SH-N-Ex, 400 V 60 Hz HP-N-Ex
1590010710	(1)	Anti-static bar P-SH-N-Ex, 440 V 60 Hz HP-N-Ex
1590010810	(1)	Anti-static bar P-SH-N-Ex, 480 V 60 Hz HP-N-Ex
3610300000	(2)	Air guide
6605314860	(3)	Blower 230/400 V 50 Hz 3 ph HP-N-Ex
6605314850	(3)	Blower 230/400 V 60 Hz 3 ph HP-N-Ex
6605314900	(3)	Blower 440 V 60 Hz 3 ph HP-N-Ex
6605314910	(3)	Blower 480 V 60 Hz 3 ph HP-N-Ex

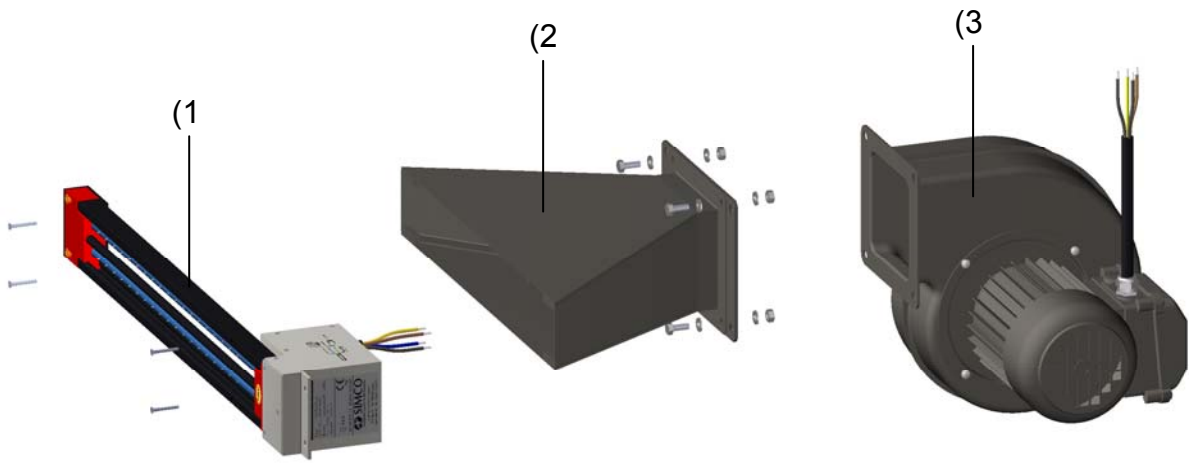

Fig. 2 Spare parts HP-N-Ex

# EC Declaration of Conformity





Manufacturer: Simco (Nederland) B.V.

We declare under our sole responsibility that the product as described, is in conformity with the following standards.

Product description: Ionising Air Blower consisting out of:  
Ionising bar P-Sh-N-Ex and blower DNG-47/S

Type **HP-N-Ex**

Applicable Directives: EC- Low Voltage Directive (2006/95/EC)  
EC- Machinery Directive (98/37/EC)  
EC- Electromagnetic compatibility (89/336/EEC)  
EC- Potential Explosive Atmospheres ATEX (94/9/EC)

Classified Area:  II 2G Ex smb IIB T4 (Bar) 1180  
 II 2G c T4 / T3 (Blower)  
 II 2G Ex e II T4 / T3 (Motor) 0102

Notified Body + Certif. nr : Baseefa 1180 BAS00ATEX2162X (blower in var. 4.5)  
PTB 0102 PTB02ATEX3114

Used Harmonized Standards: DIN EN 292-1 / DIN-EN292-2: 2000  
DIN EN 60204-1: 1998  
EN 50081-2: 1993  
EN 61000-6-2 2001  
EN 60079-0: 2006  
DIN EN 60079-10: 1996  
EN 60079-18: 2004  
DIN EN 1127-1: 1997  
DIN EN 13463-1: 2002  
DIN EN 13463-5: 2001  
DIN EN 14986: 2007

Used National Standards: CSA C22.2 No. 60950-00/UL60950 Third edition  
CAN/CSA-C22.2 No. 60950-1-03/UL 60950-1 First edition  
SFA 3009: 1985

Place, Date, Signature: Lochem, 02 March 2009,

Position and name: TSQ Manager, B.W. Bel