

FAG

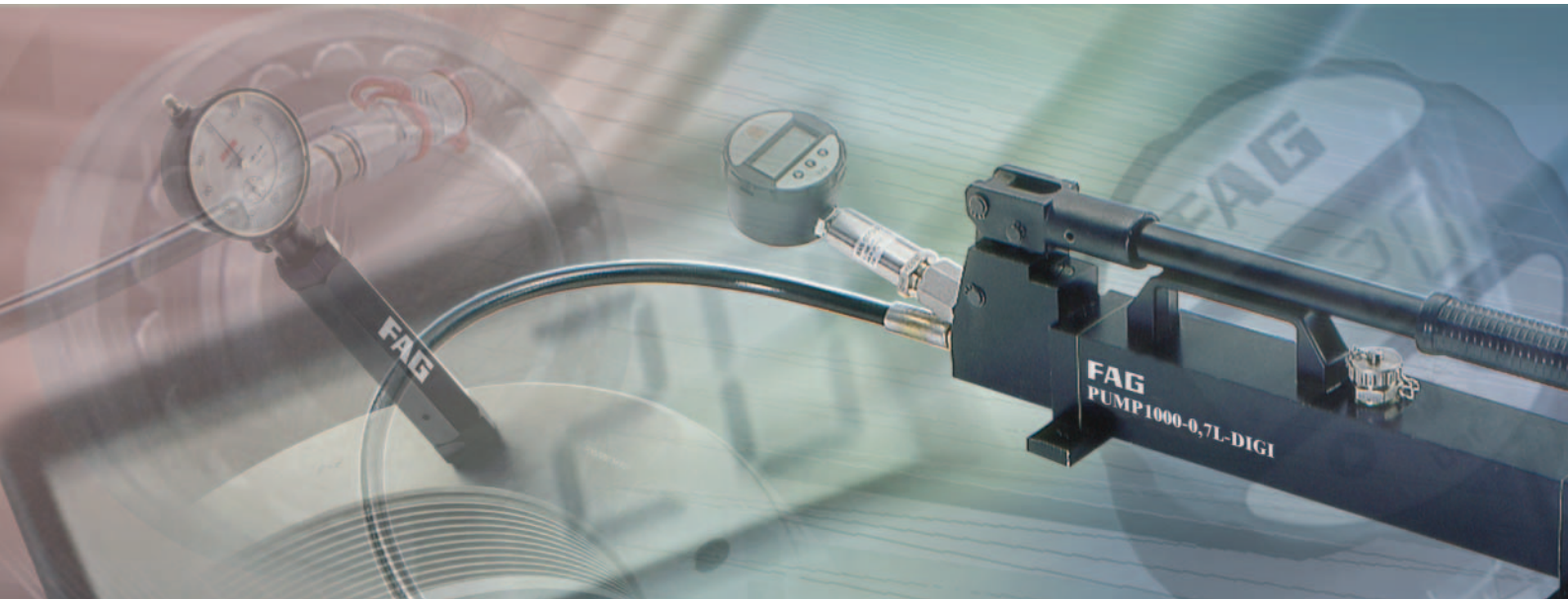

FAG pressure generation devices

Technical Product Information

SCHAEFFLER GROUP
INDUSTRIAL

Note on ordering designations

In addition to the current ordering designations printed **bold**, the previous ordering designations are also given in brackets.

Frequently used units for pressure and contact pressure

1 bar = 10^5 N/m²
= 0,1 N/mm² (MPa)
≈ 14,5 psi (lbf/in²)
1 psi ≈ 0,07 bar

Overview table

Overview table of pressure generation devices

Pressure device	Oil container volume	Connector	Max. oil pressure bar (psi)	Application	Max. shaft diameter mm	Page
Ordering designation	l					
Oil injector INJECT1600 (OILINJECTOR1600)	0,027	G ³ / ₄	1 600 (23 200)	Mounting and dismounting of bearings with tapered bore. Press fits up to approx. 80 N/mm ² contact pressure.	150	2
Oil injector INJECT2500 (OILINJECTOR2500)	0,008	G ³ / ₈	2 500 (36 250)	Mounting and dismounting of bearings with tapered bore. Press fits up to approx. 125 N/mm ² contact pressure.	80	2
Hand pump set single stage PUMP1000-0,7L (PUMP1000.0,7L)	0,7	G ¹ / ₄	1 000 (14 500)	Mounting and dismounting of rolling bearings Mounting of press fits up to approx. 50 N/mm ² contact pressure. For driving hydraulic nuts up to HYDNUT395 / HYDNUT300-HEAVY	250	3
Hand pump set twin stage PUMP1000-4L (PUMP1000.4L)	4	G ¹ / ₄	1 000 (14 500)	Mounting and dismounting of rolling bearings Mounting of press fits up to 50 N/mm ² contact pressure, e.g. for ships' propellers. For driving hydraulic nuts up to HYD.NUT800	Unlimited	4
Hand pump set twin stage PUMP1600-4L (PUMP1600.4L)	4	G ¹ / ₄	1 600 (23 200)	Mounting and dismounting of rolling bearings Mounting of press fits up to 80 N/mm ² contact pressure, e.g. for rudder spindles and rudder blades	Unlimited	5
Hand pump set twin stage PUMP2500-4L (PUMP2500.4L)	4	G ¹ / ₄ (direct)	2 500 (36 250)	Mounting and dismounting of rolling bearings Mounting of press fits up to 125 N/mm ² contact pressure, e.g. for gears and couplings	Unlimited	6
High pressure pump PUMP4000-0,2L (PUMP4000.0,2L)	0,2	G ¹ / ₄ (direct)	4 000 (58 000)	For press fits with high contact pressure (> 100 N/mm ²). Dismantling of bearings with cylindrical bore.	Unlimited	8
High pressure pump set PUMP2500-0,2L-KIT (PUMP2500.0,2L.SET)	0,2	G ¹ / ₄ with high pressure pipe	2 500 (36 250)	Flow rate and oil reservoir are small.	For rolling bearings up to ø 250	9
Compressed air driven hydraulic unit AGGREG-P1000-P2500 (AGGREGATE.P1000/2500)	13	G ¹ / ₄	2 500 (36 250)	Mounting of shaft couplings and press fits, gears etc. by the hydraulic method. Contact pressure up to 100 N/mm ²	Unlimited	10
Electrically driven hydraulic unit AGGREG-E700 (AGGREGATE.E700)	10	G ¹ / ₄	700 (10 150)	For driving large hydraulic nuts up to HYD.NUT1180. Mounting of large press fits: ship shaft couplings, ships' propellers, gears, contact pressure up to 50 N/mm ²	Unlimited	10

FAG oil injectors

FAG oil injectors

Oil injectors have a small volume displacement; they can be used in the hydraulic method for the dismantling of rolling bearings and other press fits with direct seating

on tapered shafts, e.g. in machine tools for cylindrical roller bearings FAG NNU49..-S-K, NN30..-AS-K, N10..-K, N19..-K. The INJECT2500 can be used for shaft diameters up to 80 mm, the INJECT1600 up to 150 mm.

Conventional O rings can be used as replacement seals: OR6x1,5 (for INJECT2500), OR10x2,0 (for INJECT1600).

Oil injectors and valve nipples

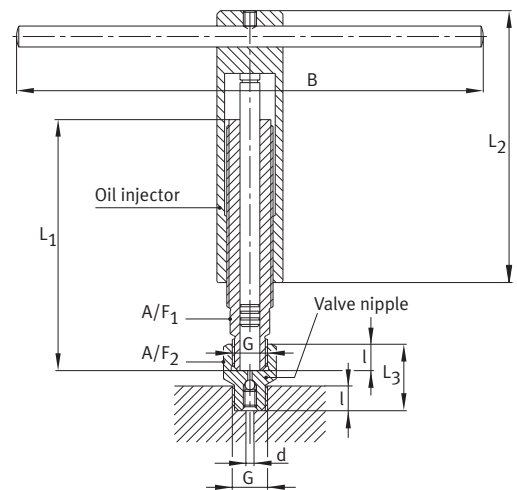
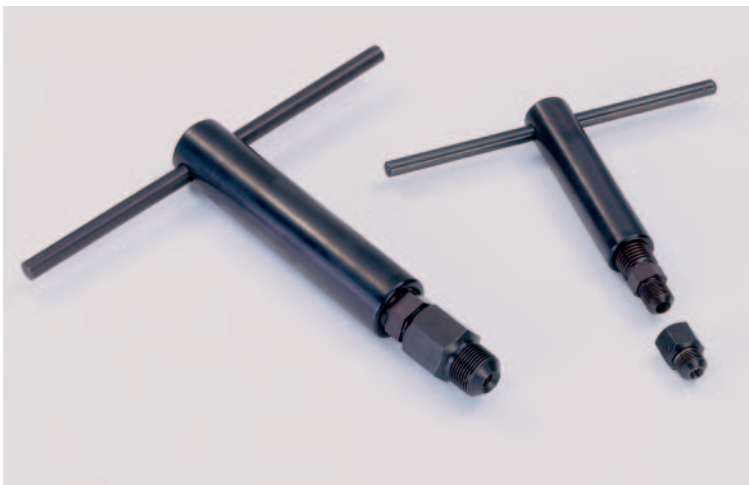

Oil injector	Valve nipple	Connector	Oil volume	Max. oil pressure	Mass	Dimensions							
		G	cm ³	bar	≈ kg	l	d	L ₁	L ₂	L ₃	B	A/F ₁	A/F ₂
Ordering designation													
INJECT2500 (OILINJECTOR2500)	INJECT2500.VALVE (OILINJECTOR2500.VALVE)	G ³ / ₈	8	2 500	0,91	12	5	120	130	30	220	19	22
INJECT1600 (OILINJECTOR1600)	INJECT1600.VALVE (OILINJECTOR1600.VALVE)	G ³ / ₄	27	1 600	2,18	22	8	180	185	55	280	27	32

The oil injector can be refilled with oil without losses by connecting the valve nipple to the oil injector. In this case, the oil injector is ordered with a valve nipple.
 Ordering designation for INJECT2500 + INJECT2500.VALVE: **INJECT2500-SET**,
 ordering designation for INJECT1600 + INJECT1600.VALVE: **INJECT1600-SET**.

FAG hand pump sets · Hand pump set, 1 000 bar (oil container 0,7 l)

Pressure generation devices for the hydraulic method and for hydraulic nuts

FAG hand pump sets

The range of FAG hand pump sets comprises the basic designs:

- PUMP1000-0,7L (single stage)
- PUMP1000-4L (twin stage)
- PUMP1600-4L (twin stage)
- PUMP2500-4L (twin stage)

The twin stage pumps have a high flow rate in the low pressure range and then switch automatically to the high pressure stage. This gives a high work rate.

Where there is an increased oil requirement, the twin stage pumps are alternatively available with an 8 litre oil container (suffix -8L).

For those cases in which the type of installation of the adapter or extraction sleeve requires a separate oil supply, we can upon request supply a two-way valve (suffix D).

FAG hand pump set, 1 000 bar (oil container 0,7 l)

The hand pump set is suitable for the mounting and dismounting of rolling bearings by the hydraulic method, the mounting of press fits up to 50 N/mm² contact pressure and for driving hydraulic nuts up to HYDNUT395 or HYDNUT300-HEAVY. The oil container has a volume of 0,7 l. The pump is connected using a high pressure hose, 1000 bar, 1,5 m long and a plug-in coupling, 1000 bar (for a threaded connector bore G¹/₄, see drawing). For the mounting and dismounting of rolling bearings with adapter or extraction sleeves, sleeve connectors must be used. If other connectors are present, adapters and reduction nipples can be used.

The pump set is supplied ready-to-use in a metal case.

Included in delivery:

- 1 hand pump, 1000 bar with 0,7 l oil container filled with Shell Voltol Gleitöl 46 oil (viscosity 46 mm²/s at 40 °C), manometer, connector in pump head
 - 1 manometer, 0–1000 bar (ø 63 mm)
 - 1 high pressure hose, 1000 bar, 1,5 m long
 - 1 plug-in coupling, 1000 bar (connector thread G¹/₄)
 - 1 metal case 650×260 x 200 mm
- Mass (including oil charge and metal case) 10 kg

Ordering designation:

PUMP1000-0,7L
(PUMP1000.0,7L)

The hand pump set can also be supplied with a digital manometer.

Ordering designation for repair set for single stage 1000 bar pump:

PUMP1000-0,7L.SPARE-KIT
(PUMP1000.0,7L.KIT)



Hand pump set, 1000 bar (0,7 l)

Oil volume per stroke cm³

2,2

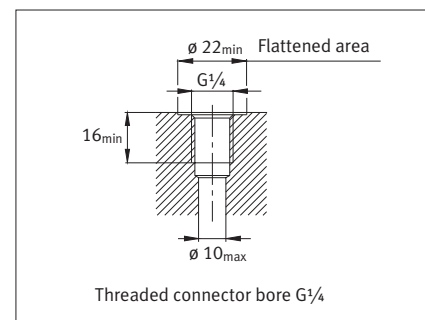

FAG hand pump sets, 1 000 bar (oil container 4 l)

Pressure generation devices for the hydraulic method and for hydraulic nuts

FAG hand pump sets, 1 000 bar (oil container 4 l)

The hand pump sets are suitable for the mounting and dismounting of rolling bearings and for the mounting of press fits up to 50 N/mm², e.g. for ships' propellers, using the hydraulic method. Hand pump sets with a 4 l oil container can be used to drive hydraulic nuts up to HYDNUT800 (alternatively, 8 l oil containers can be used for larger hydraulic nuts).

The pump is connected using a high pressure hose, 1000 bar, 2 m long and a plug-in coupling, 1000 bar (for a threaded connector bore G¹/₄, see drawing on page 3). If two connectors must be supplied with oil at the same time, the pump set can be supplied fitted with a two-way valve. The oil is then supplied via two high pressure hoses and two plug-in couplings. The pump set is supplied ready-to-use in a metal case.

Hand pump set PUMP1000-4L (for 1 connector)

Included in delivery:

- 1 hand pump, 1000 bar with 4 l oil container filled with Shell Voltol Gleitöl 46 oil (viscosity 46 mm²/s at 40 °C)
 - 1 flange-mounted manometer connector
 - 1 manometer, 0–1000 bar (ø 63 mm)
 - 1 high pressure hose, 1000 bar, 2 m long
 - 1 plug-in coupling, 1000 bar
 - 1 metal case 900×250×250 mm
- Mass (including oil charge and metal case) 24 kg

Ordering designation:
PUMP1000-4L
(PUMP1000.4L)

The hand pump set with 1 connector can also be supplied with a digital manometer.

Hand pump set PUMP1000-4L-D (for 2 connectors)

Included in delivery:

- 1 hand pump, 1000 bar with 4 l oil container filled with Shell Voltol Gleitöl 46 oil (viscosity 46 mm²/s at 40 °C)
 - 1 flange-mounted two-way valve (with manometer connector)
 - 1 manometer, 0–1000 bar (ø 63 mm)
 - 2 high pressure hoses, 1000 bar, 2 m long
 - 2 plug-in couplings, 1000 bar
 - 1 metal case 900×250×250 mm
- Mass (including oil charge and metal case) 27 kg

Ordering designation:
PUMP1000-4L-D
(PUMP1000.4L.D)

Ordering designation for repair set for twin stage 1000 bar pumps:
PUMP1000-4L.SPARE-KIT
(PUMP1000.4L.KIT)



Hand pump set, 1000 bar (4 l)

Oil volume per stroke
up to 30 bar 30 to 1000 bar
cm³

32 1,6

FAG hand pump sets, 1 600 bar

Pressure generation devices for the hydraulic method

FAG hand pump sets, 1 600 bar

The hand pump sets, 1 600 bar are suitable for the mounting and dismantling of rolling bearings and for the mounting of press fits up to 80 N/mm², e.g. for rudder spindles and rudder blades, using the hydraulic method.

The oil containers have a volume of 4 l (upon request 8 l).

The pump is connected using a high pressure hose, 1 600 bar, 2 m long and a plug-in coupling, 1 600 bar (for a threaded connector bore G³/₄, see drawing on page 3).

If two connectors must be supplied with oil at the same time, the pump set can be supplied fitted with a two-way valve. The oil is then supplied via two high pressure hoses and two plug-in couplings.

The pump sets are supplied ready-to-use in a metal case.

Hand pump set PUMP1600-4L (for 1 connector)

Included in delivery:

- 1 hand pump, 1 600 bar with 4 l oil container filled with Shell Voltol Gleitöl 46 oil (viscosity 46 mm²/s at 40 °C)
 - 1 flange-mounted manometer connector
 - 1 manometer, 0–1 600 bar (∅ 100 mm)
 - 1 high pressure hose, 1 600 bar, 2 m long
 - 1 plug-in coupling, 1 600 bar
 - 1 metal case 900×250×250 mm
- Mass (including oil charge and metal case) 25 kg

Ordering designation:

PUMP1600-4L
(PUMP1600.4L)

Hand pump set PUMP1600-4L-D (for 2 connectors)

Included in delivery:

- 1 hand pump, 1 600 bar with 4 l oil container filled with Shell Voltol Gleitöl 46 oil (viscosity 46 mm²/s at 40 °C)
 - 1 flange-mounted two-way valve (with manometer connector)
 - 1 manometer, 0–1 600 bar (∅ 100 mm)
 - 2 high pressure hoses, 1 600 bar, 2 m long
 - 2 plug-in couplings, 1 600 bar
 - 1 metal case 900×250×250 mm
- Mass (including oil charge and metal case) 28 kg

Ordering designation:

PUMP1600-4L-D
(PUMP1600.4L.D)

Ordering designation for repair set for twin stage 1 600 bar pumps:

PUMP1600-4L.SPARE-KIT
(PUMP1600.4L.KIT)



Hand pump set, 1 600 bar

Oil volume per stroke
up to 30 bar 30 to 1 600 bar
cm³

32 1,6

FAG hand pump sets, 2 500 bar

Pressure generation devices for the hydraulic method

FAG hand pump sets, 2 500 bar

The hand pump sets, 2 500 bar are suitable for the mounting and dismounting of rolling bearings and for the mounting of press fits up to 125 N/mm², e.g. for gears and couplings, using the hydraulic method.

The oil containers have a volume of 4 l (upon request 8 l).

The pump is connected using a high pressure hose, 2 500 bar, 2 m long, via a reduction nipple or adapter (for dimensions and connector bore, see drawing and table). If two connectors must be supplied with oil at the same time, the pump set can be supplied fitted with a two-way valve. The oil is then supplied via two high pressure hoses.

The pump sets are supplied ready-to-use in a metal case.

Hand pump set PUMP2500-4L (for 1 connector)

Included in delivery:

- 1 hand pump, 2 000 bar with 4 l oil container filled with Shell Voltol Gleitöl 46 oil (viscosity 46 mm²/s at 40 °C)
 - 1 flange-mounted manometer connector
 - 1 manometer, 0–2 500 bar (ø 100 mm)
 - 1 high pressure hose, 2 500 bar, 2 m long
 - 1 nipple plug G¹/₄
 - 1 each adapter G¹/₄, reduction nipple G³/₈, G¹/₂, G³/₄
 - 1 metal case 940×280×280 mm
- Mass (including oil charge and metal case) 27 kg

Ordering designation:

PUMP2500-4L
(PUMP2500.4L)

Hand pump set PUMP2500-4L-D (for 2 connectors)

Included in delivery:

- 1 hand pump, 2 500 bar with 4 l oil container filled with Shell Voltol Gleitöl 46 oil (viscosity 46 mm²/s at 40 °C)
 - 1 flange-mounted two-way valve (with manometer connector)
 - 1 manometer, 0–2 500 bar (ø 100 mm)
 - 2 high pressure hoses, 2 500 bar, 2 m long
 - 2 nipple plugs G¹/₄
 - 2 each adapters G¹/₄, reduction nipples G³/₈, G¹/₂, G³/₄
 - 1 metal case 940×280×280 mm
- Mass (including oil charge and metal case) 30 kg

Ordering designation:

PUMP2500-4L-D
(PUMP2500.4L.D)

Ordering designation for repair set:
PUMP2500-4L.SPARE-KIT

Oil volume per stroke

up to 20 bar 20 to 2 500 bar
cm³

32

0,9

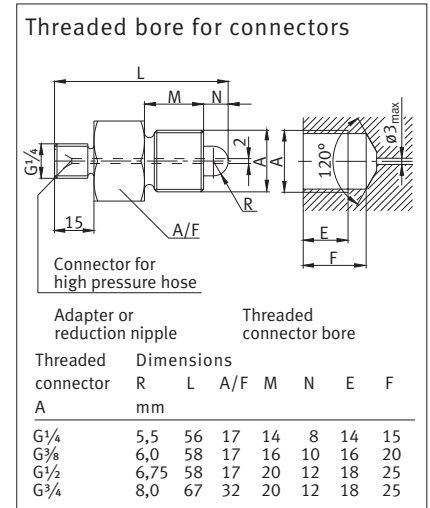

FAG hand pump sets

Overview of ordering designations



Hand pump set PUMP1000-0,7L-DIGI



Hand pump set PUMP2500-8L-D

FAG hand pump sets (overview of ordering designations)

Pump	Hand pump set Basic design	With 8 l oil container	With distributor	With 8 l oil container and distributor
Single stage				
1 000 bar	PUMP1000-0,7L*			
Twin stage				
1 000 bar	PUMP1000-4L*	PUMP1000-8L*	PUMP1000-4L-D	PUMP1000-8L-D
1 600 bar	PUMP1600-4L	PUMP1600-8L	PUMP1600-4L-D	PUMP1600-8L-D
2 500 bar	PUMP2500-4L	PUMP2500-8L	PUMP2500-4L-D	PUMP2500-8L-D

* The 1 000 bar pumps with one connector are also available with a digital manometer (see page 14).

Ordering example: **PUMP1000-0,7L-DIGI**

Repair sets:

PUMP1000-0,7L.SPARE-KIT	0,2 kg
PUMP1000-4L.SPARE-KIT	0,4 kg
PUMP1600-4L.SPARE-KIT	0,4 kg
PUMP2500-4L.SPARE-KIT	0,6 kg

FAG high pressure pump

FAG high pressure pump PUMP4000-0,2L

The high pressure pump is suitable for the mounting and dismantling of rolling bearings for shaft diameters up to 250mm. Since it generates pressures of up to 4 000 bar, the pump can be used to expand heavy shaft couplings and gears by the hydraulic method.

The pump is connected directly or via thick-walled adapters.

The high pressure pump can also be connected via a pump holder (with or without a manometer) and a 2 m long flexible high pressure hose (maximum permissible oil pressure 2 500 bar).

The pump must always be operated with a manometer.

Recommended oil for normal ambient temperature: mineral oil with a nominal viscosity of 68 mm²/s at 40 °C.

Handling of the pump is described in the user manual (publication WL 80 115).

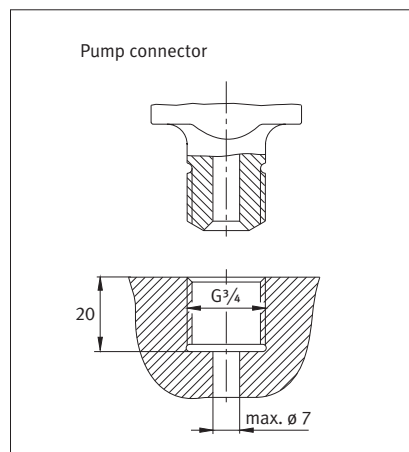
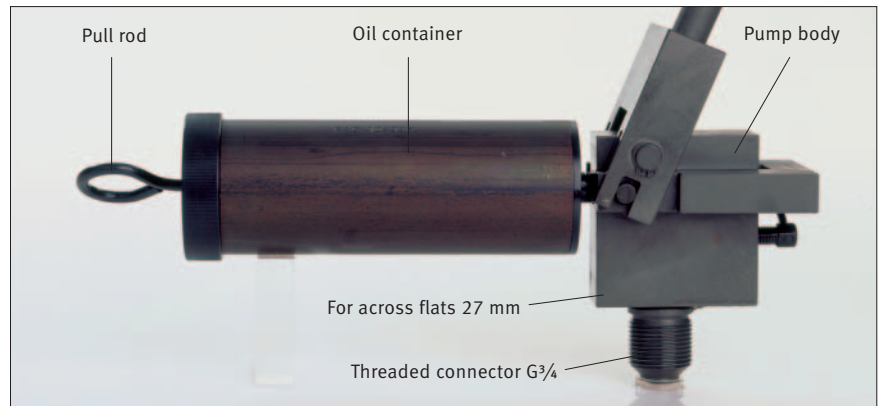

FAG high pressure pump PUMP4000-0,2L

High pressure pump	Connector	Oil container volume	Flow rate	Max. oil pressure	Mass
Ordering designation		l	cm ³ /stroke	bar	≈ kg
PUMP4000-0,2L ¹⁾ comprising PUMP4000-0,2L.BODY (pump body) PUMP4000-0,2L.TANK (oil container)	G ³ / ₄	0,2	0,3	4 000	3,8
¹⁾ Previous designation: PUMP4000.0,2L					

FAG high pressure pump sets

FAG high pressure pump sets

In order to make it easier to select the right device, FAG supplies complete sets in storage cases:
 FAG high pressure pump set PUMP2500-0,2L-KIT with manometer up to 2 500 bar (previous designation: PUMP2500.0,2L.SET).



FAG high pressure pump set PUMP2500-0,2L-KIT

FAG high pressure pump set PUMP2500-0,2L-KIT with manometer up to 2 500 bar

Included in delivery:

1 high pressure pump	PUMP4000-0,2L	1 manometer	PUMP2500.MANO-G $\frac{1}{2}$
1 pump holder	PUMP.HOLDER-3	1 high pressure pipe	PUMP.PIPE-G $\frac{1}{4}$
3 reduction nipples	(PUMP.NIPPLE-B-G $\frac{1}{4}$ -G $\frac{1}{8}$, PUMP.NIPPLE-B-G $\frac{1}{4}$ -G $\frac{3}{4}$, PUMP.NIPPLE-B-G $\frac{1}{4}$ -G $\frac{1}{2}$)	1 storage case	
		Mass (including case)	12,75 kg

Ordering designation for kit: **PUMP2500-0,2L-KIT**
 (previous designation: PUMP2500.0,2L.SET)

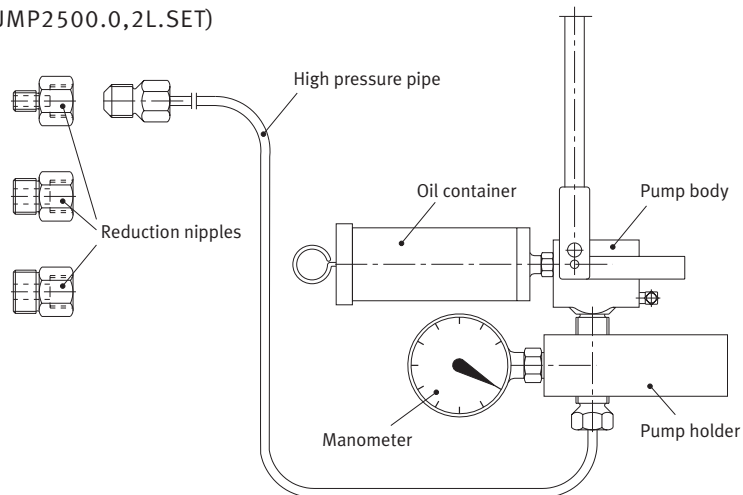

FAG hydraulic units

Compressed air driven FAG hydraulic unit

The compressed air driven hydraulic unit AGGREG-P1000-P2500 is mobile and comprises a 13 l oil container made from light metal and two pumps (1000 bar and 2 500 bar). We supply designs for other operating pressures by agreement.

The pump (2 500 bar) has two independently controllable outputs and is suitable as a pressure generation device for the hydraulic method for the expansion of shaft couplings and gears. The pump (1000 bar) can drive a hydraulic nut at the same time. The pump is suitable for press fits with contact pressures up to 100 N/mm².

Included in delivery:
basic unit, ready-to-use, including
1 manometer, 0 to 1000 bar,
1 manometer, 0 to 2 500 bar,
3 high pressure hoses, 2 500 bar,
2 m long,
1 oil distributor

Compressed air driven FAG hydraulic unit			
Hydraulic unit	Oil container volume	Max. oil pressure	Mass
Ordering designation	l	bar	≈ kg
AGGREG-P1000-P2500 (AGGREGATE.P1000/2500)	13	1000 or 2 500	40 (without oil charge)

Electrically driven FAG hydraulic unit

These units are suitable for driving hydraulic nuts and for the mounting of large press fits such as ship shaft couplings, ships' propellers and gears (contact pressure up to 50 N/mm²).
Electrical connection: plug, voltage 400 V at 50 Hz.
Other voltages and frequencies by agreement.

Included in delivery:
basic unit, ready-to-use, including
1 manometer, 0 to 1000 bar,
1 high pressure hose, 1000 bar,
2 m long
1 pressure control valve

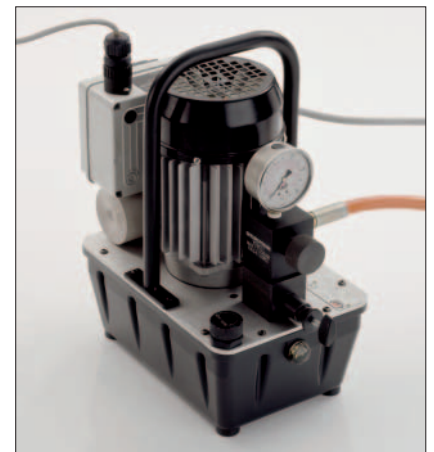

Electrically driven FAG hydraulic unit					
Hydraulic unit	Oil container volume (effective suction quantity)	Oil volume flow	Max. oil pressure	Motor power	Mass
Ordering designation	l	l/min	bar	kW	≈ kg
AGGREG-E700 (AGGREGATE.E700)	10	0,9	700	1,1	40 (with oil charge)

FAG hydraulic unit

Mobile FAG hydraulic unit for batch mounting

The mobile unit has a valve-controlled, double direction pressure cylinder (pressure force 700 kN, stroke 215 mm) driven by a motor pump.

The height position of the cylinder can be varied between 290 and 690 mm by means of a lifting cylinder and rocker.

Accessories such as guide bushes, mounting sleeves, traction and pressure spindles and drawing frames must be ordered according to the individual application.

When making enquiries or placing orders, information on the bearing type and power connection as well as installation drawings (shaft, housing, additional parts) are required.

This unit is predominantly used for the mounting and dismounting of FAG wheelset bearings TAROL (see also publication WL 07 170).

Ordering designation:

TAROL-RAILWAY-AGGREGATE
(TAROL.MOUNTING.AGGREGATE)



FAG accessories

FAG accessories

The FAG accessories include:

- adapters and reduction nipplesP. 12
- manometers P. 14
- pump holders P. 14
- high pressure pipes P. 15
- sleeve connectors for adapter and extraction sleevesP. 16

FAG adapters and reduction nipples

Adapters and reduction nipples are matched to the threads of high pressure hoses and pressure pipes. Adapters and reduction nipples of type A (with sealing ring) are suitable for oil pressures up to 800 bar.

Type B (with blade sealing) is suitable for oil pressures up to 2 500 bar.

In addition to the sizes listed here, we can supply other adapters and reduction nipples by agreement.

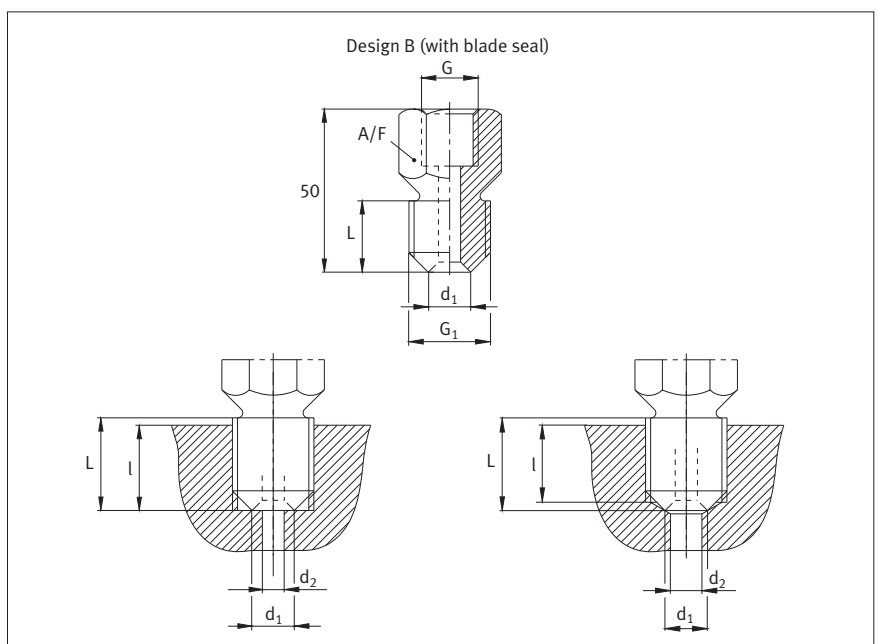
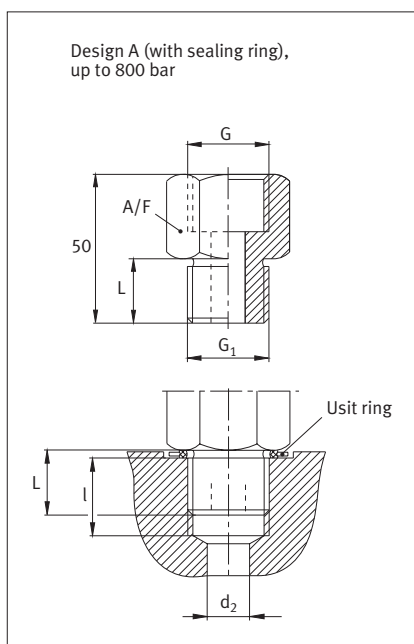

FAG accessories

Adapters

Adapters		G = G ₁						
Ordering designation	(previous ordering designation)	G	G ₁	d ₁ mm	L	Across flats A/F	Connector bore d _{2 max} l	
PUMP.ADAPTER-A-G ¹ / ₄	(PUMP.ADAPTER.A.G ¹ / ₄)	G ¹ / ₄	G ¹ / ₄		15	27	10 min 17	
PUMP.ADAPTER-B-G ¹ / ₄	(PUMP.ADAPTER.B.G ¹ / ₄)	G ¹ / ₄	G ¹ / ₄	8	17	27	5 max 15	
PUMP.ADAPTER-A-G ³ / ₄	(PUMP.ADAPTER.A.G ³ / ₄)	G ³ / ₄	G ³ / ₄		20	36	15 min 22	
PUMP.ADAPTER-B-G ³ / ₄	(PUMP.ADAPTER.B.G ³ / ₄)	G ³ / ₄	G ³ / ₄	13	22	36	9 max 20	

Reduction nipples

Reduction nipples		G ≠ G ₁						
Ordering designation	(previous ordering designation)	G	G ₁	d ₁ mm	L	Across flats A/F	Connector bore d _{2 max} l	
PUMP.NIPPLE-A-G ¹ / ₄ -G ¹ / ₈	(PUMP.NIPPLE.A.G ¹ / ₄ -G ¹ / ₈)	G ¹ / ₄	G ¹ / ₈		15	27	7 min 17	
PUMP.NIPPLE-B-G ¹ / ₄ -G ¹ / ₈	(PUMP.NIPPLE.B.G ¹ / ₄ -G ¹ / ₈)	G ¹ / ₄	G ¹ / ₈	6	17	27	4 max 15	
PUMP.NIPPLE-A-G ¹ / ₄ -G ¹ / ₂	(PUMP.NIPPLE.A.G ¹ / ₄ -G ¹ / ₂)	G ¹ / ₄	G ¹ / ₂		20	32	15 min 22	
PUMP.NIPPLE-B-G ¹ / ₄ -G ¹ / ₂	(PUMP.NIPPLE.B.G ¹ / ₄ -G ¹ / ₂)	G ¹ / ₄	G ¹ / ₂	11	22	32	8 max 20	
PUMP.NIPPLE-A-G ¹ / ₄ -G ³ / ₄	(PUMP.NIPPLE.A.G ¹ / ₄ -G ³ / ₄)	G ¹ / ₄	G ³ / ₄		20	36	15 min 22	
PUMP.NIPPLE-B-G ¹ / ₄ -G ³ / ₄	(PUMP.NIPPLE.B.G ¹ / ₄ -G ³ / ₄)	G ¹ / ₄	G ³ / ₄	13	22	36	9 max 20	
PUMP.NIPPLE-A-G ¹ / ₄ -M14	(PUMP.NIPPLE.A.G ¹ / ₄ -M14)	G ¹ / ₄	M14		15	24	10 min 17	
PUMP.NIPPLE-B-G ¹ / ₄ -M14	(PUMP.NIPPLE.B.G ¹ / ₄ -M14)	G ¹ / ₄	M14	8	17	24	5 max 15	
PUMP.NIPPLE-A-G ¹ / ₄ -M18×1,5	(PUMP.NIPPLE.A.G ¹ / ₄ -M18×1,5)	G ¹ / ₄	M18×1,5		18	27	13 min 20	
PUMP.NIPPLE-A-G ³ / ₈ -G ¹ / ₄	(PUMP.NIPPLE.A.G ³ / ₈ -G ¹ / ₄)	G ³ / ₈	G ¹ / ₄		15	27	10 min 17	
PUMP.NIPPLE-B-G ³ / ₈ -G ¹ / ₄	(PUMP.NIPPLE.B.G ³ / ₈ -G ¹ / ₄)	G ³ / ₈	G ¹ / ₄	8	17	27	5 max 15	
PUMP.NIPPLE-A-G ³ / ₄ -G ¹ / ₈	(PUMP.NIPPLE.A.G ³ / ₄ -G ¹ / ₈)	G ³ / ₄	G ¹ / ₈		15	36	7 min 17	
PUMP.NIPPLE-B-G ³ / ₄ -G ¹ / ₈	(PUMP.NIPPLE.B.G ³ / ₄ -G ¹ / ₈)	G ³ / ₄	G ¹ / ₈	6	17	36	4 max 15	
PUMP.NIPPLE-A-G ³ / ₄ -G ¹ / ₄	(PUMP.NIPPLE.A.G ³ / ₄ -G ¹ / ₄)	G ³ / ₄	G ¹ / ₄		15	36	10 min 17	
PUMP.NIPPLE-B-G ³ / ₄ -G ¹ / ₄	(PUMP.NIPPLE.B.G ³ / ₄ -G ¹ / ₄)	G ³ / ₄	G ¹ / ₄	8	17	36	5 max 15	
PUMP.NIPPLE-A-G ³ / ₄ -G ³ / ₈	(PUMP.NIPPLE.A.G ³ / ₄ -G ³ / ₈)	G ³ / ₄	G ³ / ₈		15	36	12 min 17	
PUMP.NIPPLE-B-G ³ / ₄ -G ³ / ₈	(PUMP.NIPPLE.B.G ³ / ₄ -G ³ / ₈)	G ³ / ₄	G ³ / ₈	10	17	36	7 max 15	
PUMP.NIPPLE-A-M18×1,5-G ¹ / ₄	(PUMP.NIPPLE.A.M18×1,5-G ¹ / ₄)	M18×1,5	G ¹ / ₄		15	27	10 min 17	
PUMP.NIPPLE-A-M18×1,5-G ³ / ₈	(PUMP.NIPPLE.A.M18×1,5-G ³ / ₈)	M18×1,5	G ³ / ₈		20	27	12 min 22	
PUMP.NIPPLE-A-M18×1,5-G ³ / ₄	(PUMP.NIPPLE.A.M18×1,5-G ³ / ₄)	M18×1,5	G ³ / ₄		20	36	15 min 22	

FAG accessories

for FAG high pressure pump PUMP4000-0,2L

FAG manometers

When selecting a manometer, pay attention to the max. operating pressure.

FAG manometers

Manometer	(previous ordering designation)	Threaded connector	Pressure display	Diameter	Mass
Ordering designation			bar	mm	≈ kg
PUMP1000.MANO-DIGI	(PUMP1000.MANO.DIGI)	G $\frac{1}{4}$	0-1 000	73	0,4
PUMP1000.MANO-G $\frac{1}{2}$	(PUMP1000.MANO.G $\frac{1}{2}$)	G $\frac{1}{2}$	0-1 000	100	0,8
PUMP1600.MANO-G $\frac{1}{2}$	(PUMP1600.MANO.G $\frac{1}{2}$)	G $\frac{1}{2}$	0-1 600	100	1,5
PUMP2500.MANO-G $\frac{1}{2}$	(PUMP2500.MANO.G $\frac{1}{2}$)	G $\frac{1}{2}$	0-2 500	160	1,7



FAG pump holders

FAG pump holders

Pump holder		Mass
Ordering designation		≈ kg
PUMP.HOLDER-2 (PUMP.HOLDER.2)	without connector for manometer	1,95
PUMP.HOLDER-3 (PUMP.HOLDER.3)	with connector G $\frac{1}{2}$ for manometer	1,95



PUMP.HOLDER-2 (without manometer connector)
Width 40 mm

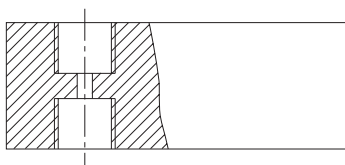

PUMP.HOLDER-3 (with manometer connector)
Width 40 mm

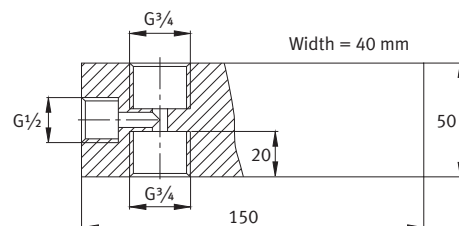

FAG accessories

for FAG high pressure pump PUMP4000-0,2L

FAG high pressure pipes, sheathed in PVC hose

A manometer is used to check that the pressure does not exceed the maximum permissible pressure of 2 500 bar.

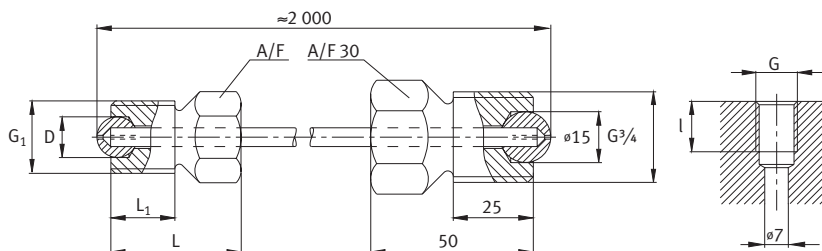

FAG high pressure pipes

High pressure pipe	Dimensions Connector	D	L	L ₁	l	A/F	Mass ≈ kg
Ordering designation	G ₁ =G	mm					
PUMP.PIPE-G₁/₄ (PUMP.PIPE.G ₁ / ₄)	G ₁ / ₄	11	35	15	15	17	0,6
PUMP.PIPE-G₃/₈ (PUMP.PIPE.G ₃ / ₈)	G ₃ / ₈	11	40	20	18	24	0,6
PUMP.PIPE-G₁/₂ (PUMP.PIPE.G ₁ / ₂)	G ₁ / ₂	11	50	25	20	24	0,6
PUMP.PIPE-G₃/₄ (PUMP.PIPE.G ₃ / ₄)	G ₃ / ₄	15	20	25	20	30	0,8

The connector for the pump holder is G₃/₄.

If other connectors are to be used, a suitable reduction nipple must be fitted.



FAG accessories

for FAG hand pump sets, 1000 bar

FAG sleeve connectors for adapter and extraction sleeves (up to 800 bar)
(special lengths by agreement)

No seal is required for connection to adapter and extraction sleeves.

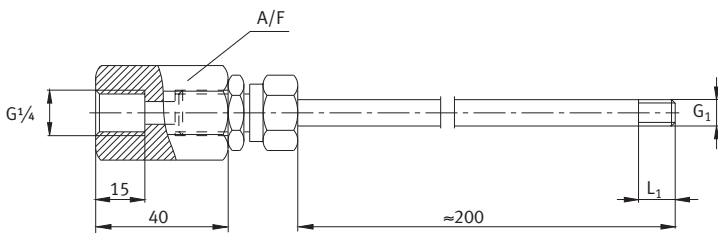

FAG sleeve connectors for adapter and extraction sleeves (up to 800 bar)

Connector	Dimensions Threaded connector G ₁	Dimensions			Mass ≈ kg
		L ₁ mm	Outside ø × thickness	A/F	
Ordering designation					
PUMP.SLEEVE-CONNECTOR-M6 (PUMP.SLEEVE.CONNECTOR.M6)	M6	6	6×2,25	24	0,22
PUMP.SLEEVE-CONNECTOR-M8 (PUMP.SLEEVE.CONNECTOR.M8)	M8	10	8×2,5	24	0,245
PUMP.SLEEVE-CONNECTOR-G1/8 (PUMP.SLEEVE.CONNECTOR.G1/8)	G1/8	11	10×2,5	24	0,285
PUMP.SLEEVE-CONNECTOR-G1/4 (PUMP.SLEEVE.CONNECTOR.G1/4)	G1/4	14	14×3	27	0,42

The connector for the hand pump set is G_{1/4}.

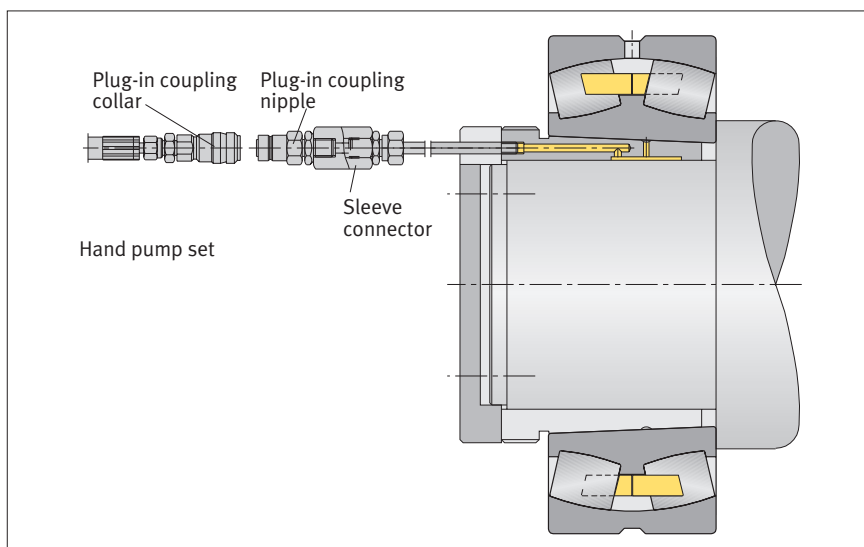

Sleeve connectors are used where, for example, a hand pump set cannot be connected directly to an adapter sleeve or extraction sleeve for reasons of space.

Schaeffler KG

Postfach 1260
97419 Schweinfurt (Germany)
Georg-Schäfer-Strasse 30
97421 Schweinfurt (Germany)

Service Hotline:

Telephone +49 2407 9149-99
Fax +49 2407 9149-59

E-mail support@fis-services.com
Internet www.fis-services.com

Every care has been taken to ensure the correctness of the information but but no liability can be accepted for any errors or omissions. We reserve the right to make modifications in the interests of technical improvement.

© Schaeffler KG · 2006, August

Reproduction in whole or in part without our authorisation is prohibited.

TPI WL 80-50/2 E