

## PGA309DK – Designer's Kit for PGA309

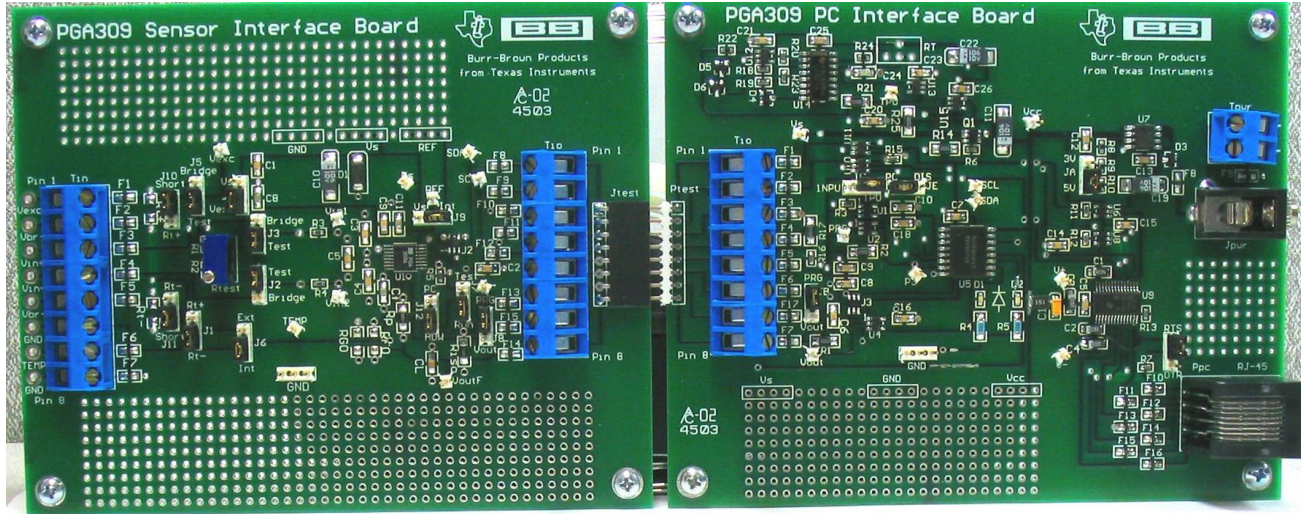

### COMPLETE EVALUATION TOOL FOR PGA309

- **PGA309 Hardware Designer's Kit**
  - Evaluate PGA309 + User's Sensor
  - Full Temperature Evaluation
- **Software Control for Designer's Kit**
  - Program PGA309 for Evaluation
  - Program PGA309 + User's Sensor in Final Module
  - Computation Analysis Tool for Calibration of PGA309 + Sensor

# Preliminary

<u>Table of Contents</u>	<u>Pages</u>
1.0 PGA309DK Parts List _____	3
2.0 Description _____	3
3.0 PGA309 Sensor Interface Board Overview _____	4-5
4.0 PGA309 PC Interface Board Overview – Part 1 _____	5-6
5.0 PGA309 PC Interface Board Overview – Part 2 _____	6-7
PGA309 Sensor Interface Board Schematic _____	8
PGA309 PC Interface Board Schematic – Page 1 of 2 _____	9
PGA309 PC Interface Board Schematic – Page 2 of 2 _____	10
6.0 Initial Setup and Checkout _____	11-21
7.0 Board Control Software Overview _____	22-31
8.0 PGA309 + Sensor Calibration Spreadsheet for Microsoft® Excel _____	32-40
9.0 General Operating Tips _____	41
10.0 PGA309DK PC Cable Drawing _____	42
11.0 PGA309DK External EEPROM Settings for Functional Test _____	43

**Note: PGA309 Documentation Availability**

Please read and familiarize yourself with the PGA309 Data Sheet and PGA309 User's Guide prior to using the PGA309DK Designer's Kit since the PGA309 features and modes are not described herein.

**Refer to Texas Instruments' Website for latest revision of:**

**PGA309 Data Sheet and PGA309 User's Guide**

<http://focus.ti.com/docs/prod/folders/print/pga309.html>

**PGA309DK User's Guide and PGA309DK Software**

<http://focus.ti.com/docs/toolsw/folders/print/pga309dk.html>

# ***Preliminary***

## **1.0 PGA309DK Parts List**

PGA309 PC Interface Board

PGA309 Sensor Interface Board

PC Cable (8-position RJ45 Plug to 9-position female DB9)

AC Wall Adapter (120Vac RMS, 60Hz in; 6Vdc, 200mA out) – USA Shipments Only

PGA309DK Software CDROM (Rev 1.0.7 or newer)

PGA309 Designer's Kit Board Control Software

PGA309 Calibration Spreadsheet for Microsoft® Excel

PGA309DK User's Manual

### **1.1 PGA309 Designer's Kit Board Control Software - Operating System Compatibility**

The Board Control Software runs on Win98, Win2000 and WinXP. Consult factory for other operating systems.

### **1.2 PGA309 Calibration Spreadsheet for Microsoft® Excel - Operating System Compatibility**

The Calibration Spreadsheet runs on Microsoft® Excel versions 2000, XP, 2003. Consult factory for other versions.

## **2.0 Description**

The PGA309DK key hardware consists of two boards (see Figure 1), PGA309 Sensor Interface Board and PGA309 PC Interface Board. The PGA309 Sensor Interface Board contains the PGA309, external SOT23-5 EEPROM, and several jumpers for ease of bridge sensor configuration. The PGA309 PC Interface Board contains an RS-232 serial interface, a 3V/5V programmable linear regulator, a switch for power control to the PGA309 Sensor Interface Board, both One-Wire and Two-Wire interface configuration and control logic, and an A/D Converter (ADS1100).

The PGA309DK is designed to allow the user to attach his sensor to the PGA309 Sensor Interface Board and place this combination in a temperature chamber. By controlling the applied pressure to the pressure sensor and the temperature of the temperature chamber, the PGA309 + Sensor combination can be calibrated for optimum end module accuracy. The PGA309 Sensor Interface Board is rated for operation from -40°C to +125°C. Power, ground, output and digital interface wires connect the PGA309 Sensor Interface Board in the temperature chamber to the external PGA309 PC Interface Board. The PGA309 PC Interface Board communicates to a test computer through a standard RS-232 serial port via the PGA309DK PC Cable. For USA shipments an AC wall adapter is included to provide 6Vdc to the PGA309 PC Interface Board. For all other applications an alternate connection on the PGA309 PC Interface Board is provided for connection to a 6Vdc (6Vdc-9Vdc) lab supply. The on-board A/D Converter, ADS1100, on the PGA309 PC Interface Board allows for easy reading of the analog output of the PGA309.

The PGA309DK Software is comprised of two parts. The Board Control Software contains all of the interface and control for communication to the PGA309 through the PGA309 PC Interface Board. It allows for reading and writing to all registers in the PGA309 as well as reading and writing to the external SOT23-5 EEPROM. Both Two-Wire and One-Wire communication options are available. In addition configuration of the PGA309 PC Interface Board and readback of the ADS1100 is provided. The PGA309 Calibration Spreadsheet for Microsoft® Excel provides a useful tool to calculate optimum temperature coefficients for the PGA309 + Sensor calibration based on real-world measurements of pressures at different temperatures. The PGA309 Calibration Spreadsheet also contains Visual Basic for Applications code that allows its integration with the Board Control Software. These macros allow the user to exchange PGA309 settings between the program and the spreadsheet and save the resulting EEPROM configuration file.

# Preliminary

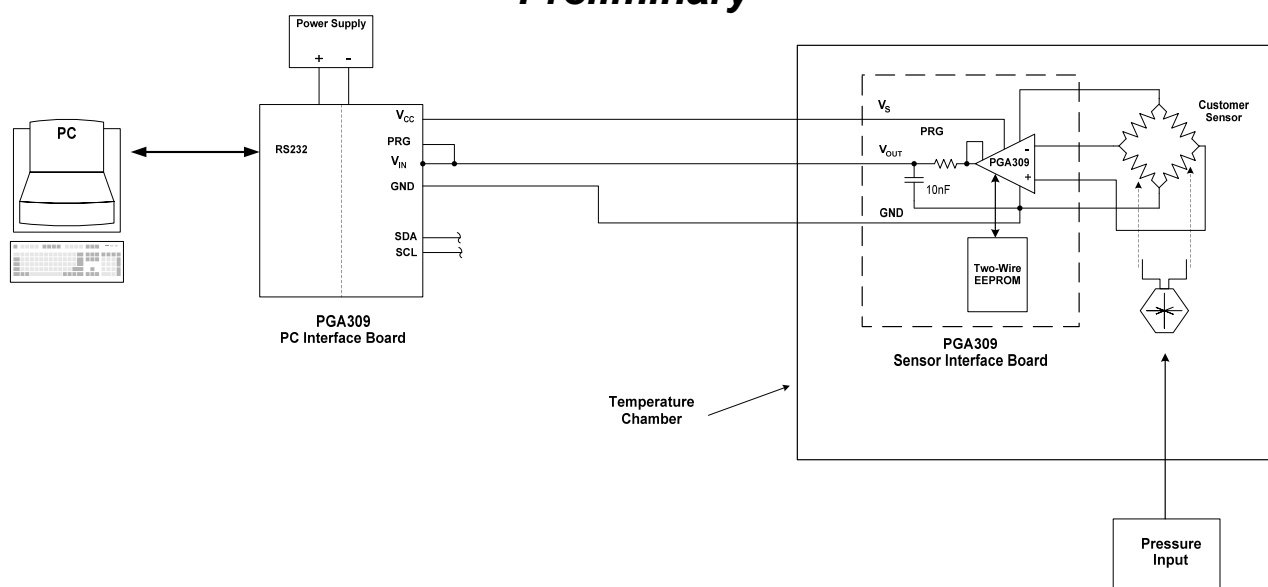

Figure 1: PGA309DK Typical System Setup

## 3.0 PGA309 Sensor Interface Board Overview

(Refer to PGA309 Sensor Interface Board Schematic)

### 3.1 Input/Output

Bridge sensor input connections are made through Tin, an 8-position screw terminal strip. In parallel with Tin are plated-through holes that are provided for solder connections if so desired. The connections from the PGA309 Sensor Interface Board to the PGA309 PC Interface Board are provided through Tio, an 8-position screw terminal strip. This connector provides ease of connections to wires for the required selected signals when placing the PGA309 Sensor Interface Board inside a temperature chamber for PGA309 + Sensor calibration. In parallel with Tio is Jtest which provides a means for direct plug-in connection to the PGA309 PC Interface Board. This is useful for initial checkout of the PGA309DK system.

### 3.2 Jumper Configuration

J1, J2, J3, J4, J5, J10 and J11 allow flexibility in the configuration of the connection to a bridge sensor. These jumpers also allow connection of the on-board test resistor  $R_{TEST}$  used for testing functionality of the PGA309 without any bridge sensor connected. Rt+ and Rt- allow for resistors to be used in the top or bottom of the bridge sensor's excitation path for one method of measuring bridge temperature by total bridge resistance changes. Jumper J6 is used to configure the PGA309 circuit for external or internal temperature sensing. If external temperature sensing using an RTD or external diode is to be used then set J6 to EXT and remove the J1 jumper entirely to avoid any interaction with Rt+ or Rt-. J9 provides hardware configuration for either internal or external reference voltage. J8 is used when Vout is to be tied to PRG for a 3-terminal sensor module configuration. J12 and J7 together decide if the Test pin on the PGA309 is to be controlled by the PGA309 PC Interface Board or hardware-programmed on the PGA309 Sensor Interface Board.

### 3.3 PGA309 + External SOT23-5 EEPROM

U1 is the PGA309 for evaluation. Also on-board is a 16k-bit, external, SOT23-5, industry standard Two-Wire, EEPROM, U2. Although the PGA309 needs only 1k-bit of external EEPROM to access its configuration registers plus the maximum number of 17 temperature coefficients, both the One-Wire and Two-Wire interfaces allow access to locations in much larger EEPROMs which can be used to store user-specific information such as a serial number, lot and date code information, etc.

# **Preliminary**

## **3.4 Protection and Filtering**

The PGA309 Sensor Interface Board is configured with components to prevent mis-wire mishaps. If power is provided from the PGA309 PC Interface Board, D1, is adequate to protect from overvoltages and reverse polarity connections. CL is a standard EMI/RFI capacitor design with Riso and Rp providing up to 16V overvoltage on VoutF. Input common mode plus differential noise filtering is provided by C3, C4, C5 and R3, R4.

## **3.5 Test Points and Miscellaneous Breadboard Area**

There are several Test Points, including a 3-position one for GND, provided for ease of measuring analog signals. Also provided are reserved areas with plated-through, standard-spacing, 0.1" holes for miscellaneous proof-of-concept breadboarding as desired for a given application.

## **4.0 PGA309 PC Interface Board Overview – Part 1**

(Refer to PGA309 PC Interface Board Schematic, Sheet 1 of 2)

### **4.1 Input/Output**

The connections from the PGA309 PC Interface Board to the PGA309 Sensor Interface Board are provided through Tio, an 8-position screw terminal strip. This connector provides ease of connections to wires for the required selected signals when placing the PGA309 Sensor Interface Board inside a temperature chamber for PGA309 + Sensor calibration. In parallel with Tio is Ptest which provides a means for direct plug-in connection to the PGA309 Sensor Interface Board. This is useful for initial checkout of the PGA309DK system. Ppc is an 8-position RJ45 jack for connection through the PGA309DK PC cable to a test computer's RS-232 serial port. RS-232 compatible signals are generated through U9. Power for the PGA309 PC Interface Board is provided through either Jpwr or Tpwr. Jpwr is to be used when an AC Wall Adapter (120Vac RMS, 60Hz in; 6Vdc, 200mA out) is available – USA Shipments Only. Other applications will use a 6Vdc (6Vdc-9Vdc) lab supply and the screw terminal inputs on Tpwr. U7 provides a regulated power source of either 3V or 5V, selectable through JA. D3 provides protection from inadvertent reverse polarity connections on Jpwr or Tpwr.

### **4.2 Port Expander Configuration Control**

U5 is an 8-bit serial port expander PCF8574A which allows user control over the configuration of the PGA309 PC Interface Board. D1 and D2 are controlled by the Board Control Software and are used as diagnostic LEDs. Q1, also controlled through U5, provides a mechanism to turn power on and off to the PGA309 Sensor Interface Board by the Board Control Software. This is key when PRG is connected to Vout on the PGA309 since Vout is set to high impedance on power-up for 25ms to allow for One-Wire communication. An unused port, P3, pin 7 is available for customer use with control provided in the Board Control Software. The One-Wire pull-up resistor, R3 can be disabled through U5 to remove loading from the PGA309 Vout pin for an accurate readout through the ADS1100, U3. U5 also controls the zero calibration of the ADS1100. The Two-Wire interface can be isolated from the PGA309 Sensor Interface Board by software through U5 control of U10 and U11 or also by hardware jumper programming.

### **4.3 One-Wire Digital Interface**

On this Designer's Kit the One-Wire digital interface is the preferred mode of communication with PGA309. It is provided through the conversion of RS-232 UART signals from U9 into open drain output through U2. The resistive pull-up for the One-Wire interface is enabled or disabled through U1. The One-Wire pull-up can be disabled for an accurate PGA309 Vout reading without the extra loading due to R3. JC provides a selection for the One-Wire active pull-up (1PU) or no One-Wire active pull-up (1NPU). This feature is described in detail in Section 5.1. Jumper JB provides a mechanism for communication through Vout when PRG is tied to Vout on the PGA309 for a 3-terminal sensor module configuration.

# Preliminary

## 4.4 Two-Wire Digital Interface

Two-Wire digital interface is provided through the conversion of RS-232 signals from U9 into open drain outputs with pull-ups (SDA<sub>OUT</sub> through U6 and SCL<sub>OUT</sub> through U8). SDA<sub>IN</sub> is tied direct to U9 which is looking for <0.8V for a logic low and >2.0V (3V supply) or >2.4V (5V supply) for a logic high. U10 and U11 provide a mechanism, through software or hardware (JE), to separate the Two-Wire bus interface from the PGA309 if it is physically connected. If the PGA309 is in stand-alone mode it will be routinely accessing its external EEPROM via the Two-Wire interface as a master. By disconnecting from the PGA309 Two-Wire connections dedicated, local Two-Wire transactions on the PGA309 PC Interface Board such as reading the ADS1100, U3, can be conducted reliably and without interruption.

**Note:** *It is recommended to keep One-Wire interface on the PGA309 PC Interface Board connected to the PGA309 Sensor Interface Board even when using Two-Wire communication mode to the PGA309 and EEPROM from the PGA309DK Board Software. See Section 7.8 for details.*

## 4.5 ADS1100 (On-Board A/D Converter)

The ADS1100 is a 16-Bit A/D available to measure Vout from the PGA309. The ADS1100 is configurable through the Board Control Software. U4 provides a means of measuring the ADS1100 initial offset for improved accuracy in its readings.

## 4.6 Test Points and Miscellaneous Breadboard Area

There are several Test Points, including a 3-position one for GND, provided for ease of measuring analog signals. Also provided are reserved areas with plated-through, standard-spacing, 0.1" holes for miscellaneous proof-of-concept breadboarding as desired for a given application.

## 5.0 PGA309 PC Interface Board Overview – Part 2

(Refer to PGA309DK PC Interface Board Schematic, Sheet 2 of 2)

### 5.1 One-Wire Active Pull-Up

The One-Wire Active Pull-Up circuitry is intended to provide a fast rising edge pull-up when the One-Wire interface is connected to heavy capacitive loads such as when PRG is tied to Vout on the PGA309 and there is a 10nF capacitor on Vout to GND. In this configuration there is an extremely long rise time due to a 4.7k $\Omega$  pull-up on the One-Wire interface. One-Shot U14 is rising edge triggered only, non-retriggerable. Comparator U12 looks for a rising edge to transition above 0.7V. The One-Shot, U14, then triggers and produces a 5 $\mu$ S wide pulse which controls switch U13. When switch U13 is turned on a 200 $\Omega$  pull-up to V<sub>S</sub> is provided on the One-Wire Interface. At the end of the 5 $\mu$ S pulse the 200 $\Omega$  pull-up to V<sub>S</sub> is removed. The 5 $\mu$ S was chosen to provide a near-symmetrical rise and fall time into a 10nF load on the One-Wire interface. RT is a provisional potentiometer which can be added to change the time the active pull-up is applied to the One-Wire Interface. D5, D6 and R22 proved a clamp to keep the input of U12 inside its allowed input voltage range for reliable operation. Figure 2 illustrates the One-Wire Pull-Up into a non-capacitive load. The table shows typical values for a supply voltage of 3.0V.

# Preliminary

Tek **Stop** Single Seq 10MS/s

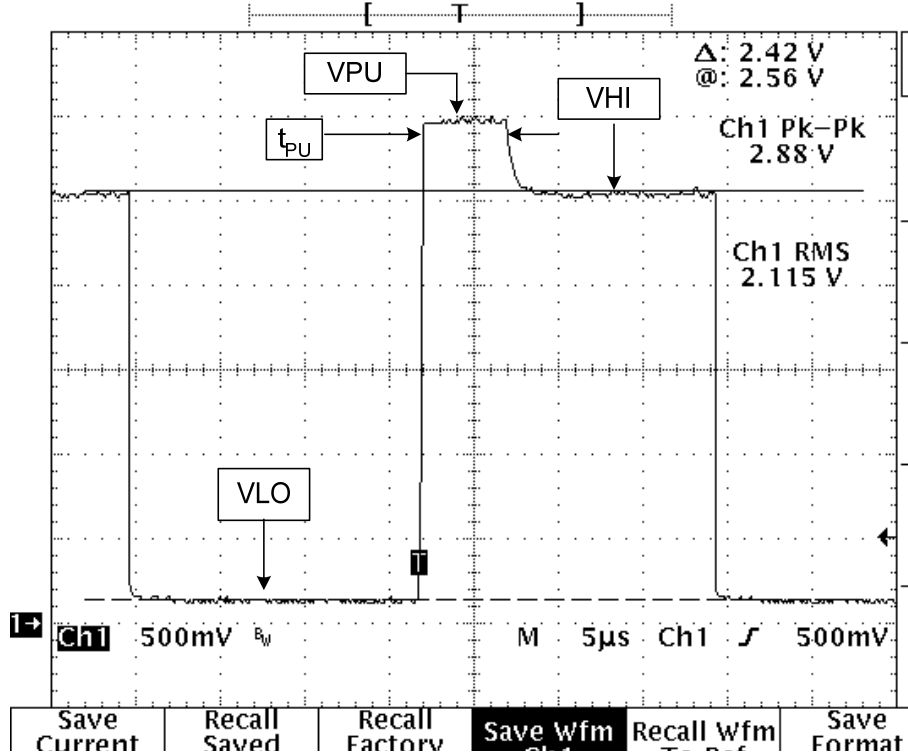

Parameter	Typical
VPU	3.0V
VHI	2.63V
VLO	122mV
$t_{PU}$	5µs

Figure 2: One-Wire Active Pull-Up Waveform and Typical Levels ( $V_S=3V$ )

## 5.2 $V_S$ Quick Discharge

It is desired at times to cycle the power on the PGA309 to be able to communicate through PRG, when it is tied to  $V_{out}$ , while  $V_{out}$  is set to high impedance by the PGA309 on initial power-up. The supply voltage on the PGA309 must decay to near zero to ensure that on power-up the state of the PGA309 is set correctly. With a 10µF capacitor on  $V_S$  on the PGA309 PC Interface Board and another 10µF capacitor on  $V_S$  on the PGA309 Sensor Interface Board reliable reset operation is guaranteed by discharging these capacitors through U15 and R25. Whenever Q1 (see Sheet 1 of 2 – PGA309 PC Interface Board Schematic) is off and disconnects power from  $V_S$  then U15 is on for quick discharge of  $V_S$ . And whenever Q1 is on then U15 is off.

# Preliminary

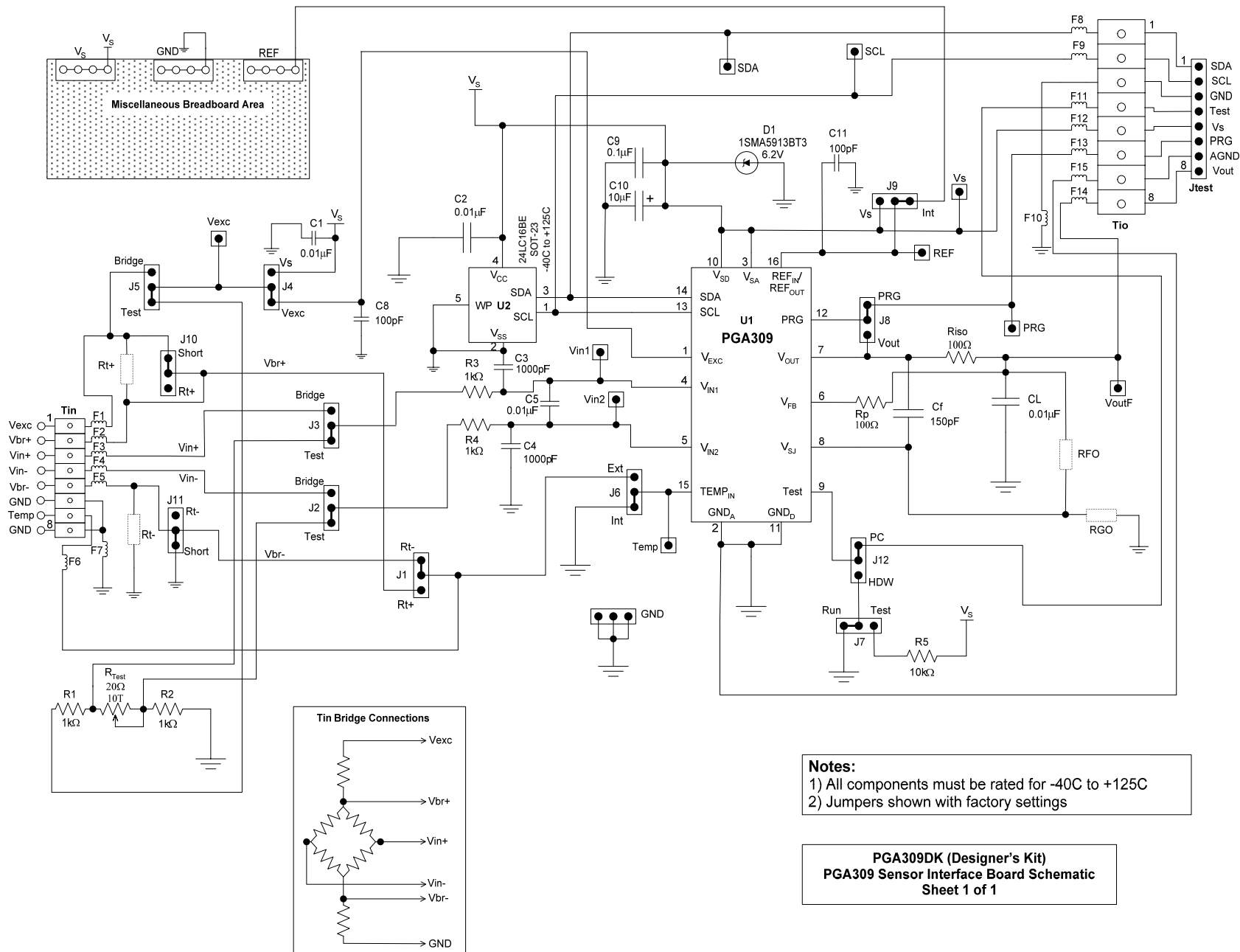

**Notes:**  
 1) All components must be rated for -40C to +125C  
 2) Jumpers shown with factory settings

**PGA309DK (Designer's Kit)**  
**PGA309 Sensor Interface Board Schematic**  
 Sheet 1 of 1



# Preliminary

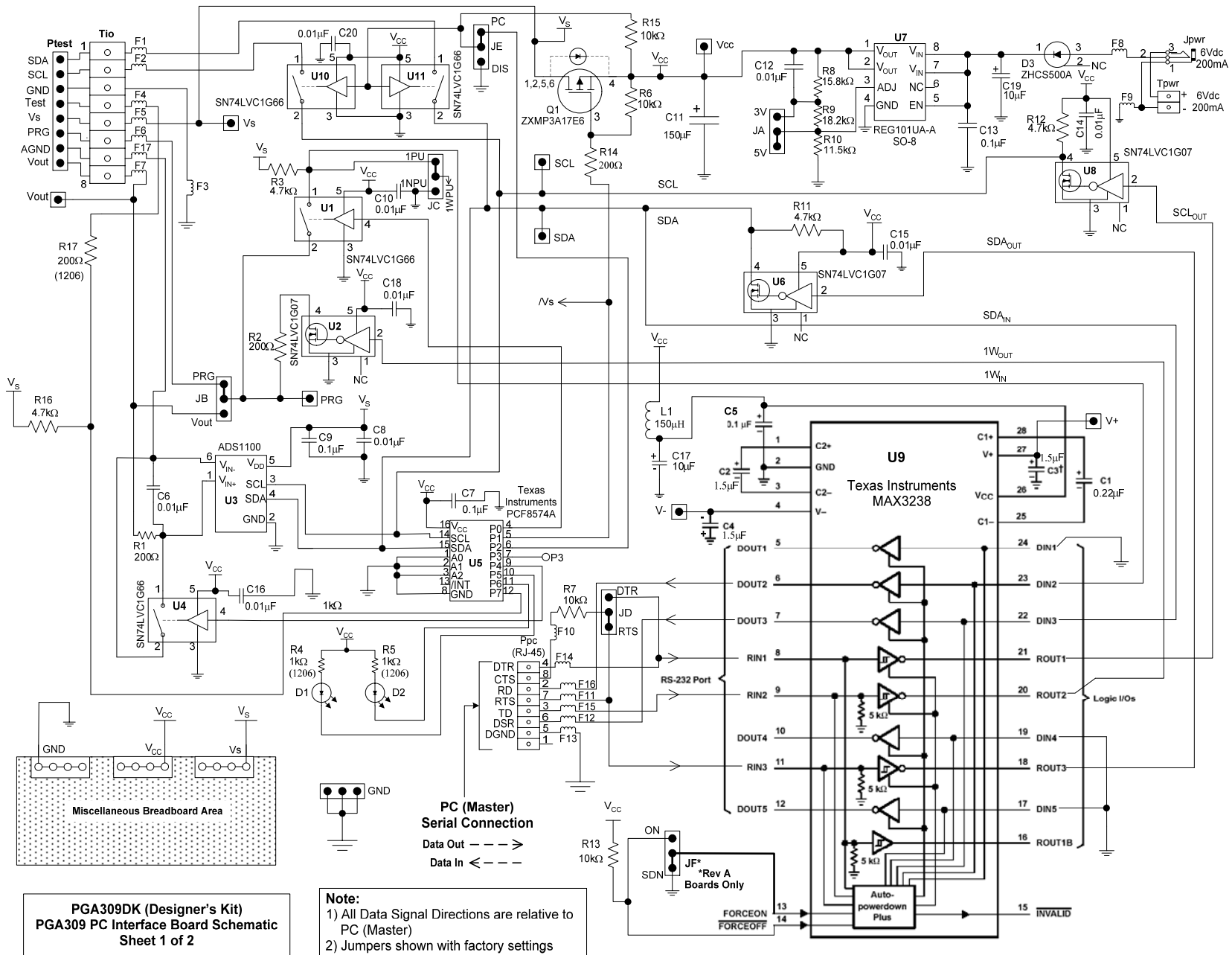

# Preliminary

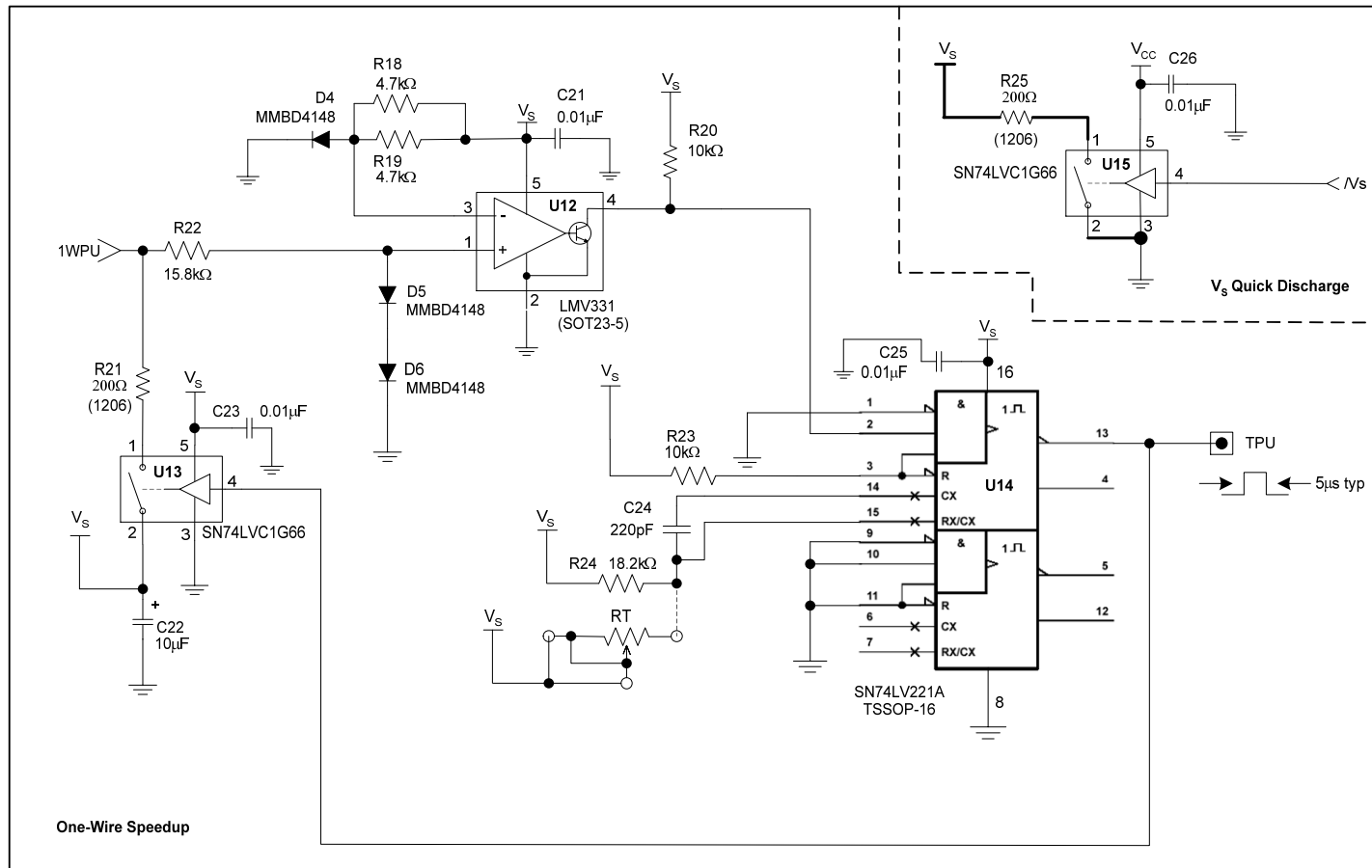

PGA309DK (Designer's Kit)  
PGA309 PC Interface Board Schematic  
Sheet 2 of 2

# Preliminary

## 6.0 Initial Setup and Checkout

### 6.1 PGA309 Sensor Interface Board – Factory Jumper Settings

Confirm and/or set the jumpers on the PGA309 Sensor Interface Board as shown in Figure 3. The desired jumper settings are also described in Table 1.

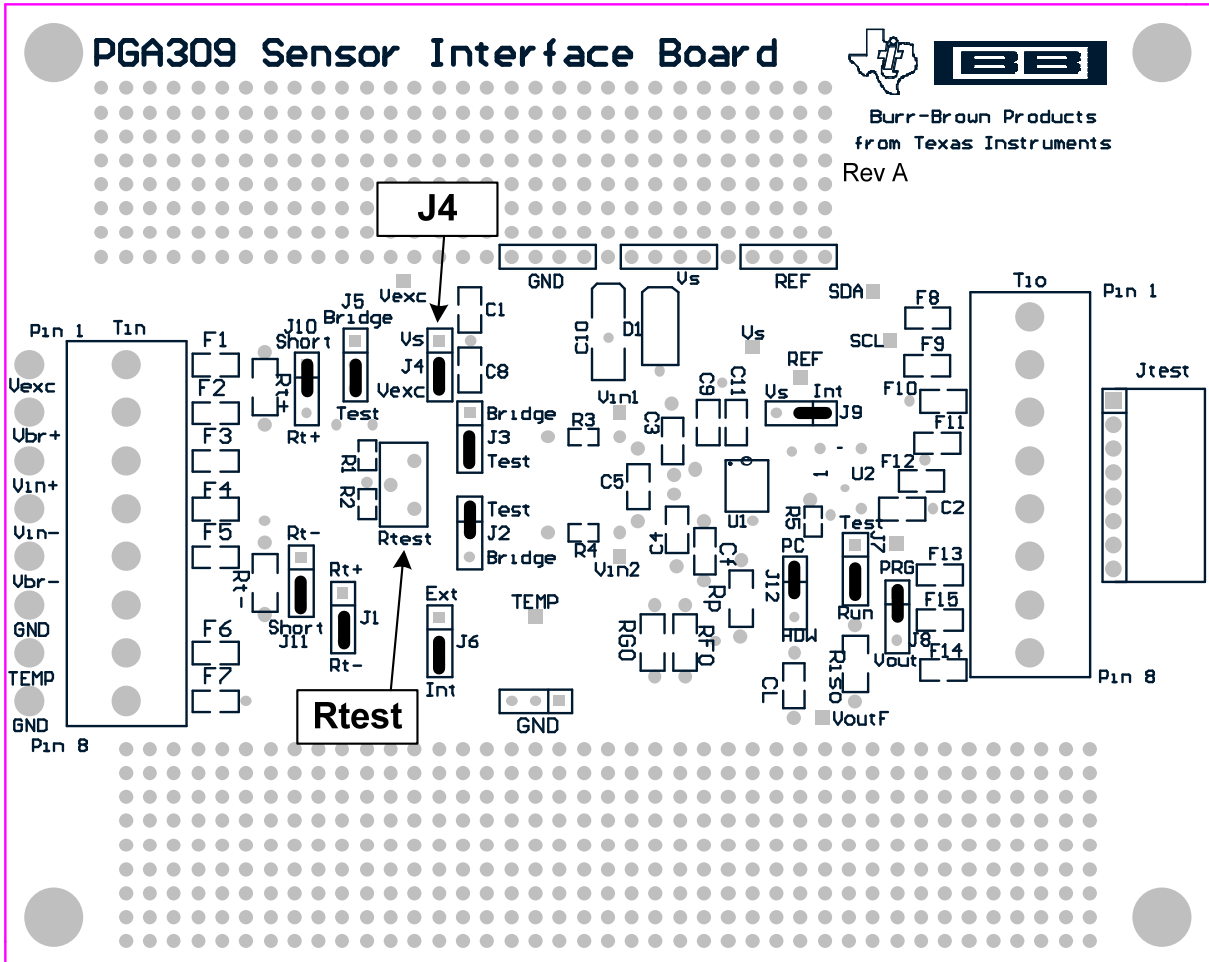

Figure 3: PGA309 Sensor Interface Board – Factory Jumper Settings

<b>PGA309 Sensor Interface Board – Factory Jumper Settings</b>		
<b>Jumper</b>	<b>Position</b>	
J1	Rt-	Use on-board pot for bridge
J2	TEST	Use on-board pot for bridge
J3	TEST	Use on-board pot for bridge
J4	VEXC	Use PGA309 Vexc
J5	TEST	Use on-board pot for bridge
J6	INT	Use on-chip temp sensor
J7	RUN	Use EEPROM for settings
J8	PRG	PRG not connected to VOUT
J9	INT	Internal Reference
J10	SHORT	Use on-board pot for bridge
J11	SHORT	Use on-board pot for bridge
J12	PC	PC Interface Board control for Test Mode

# Preliminary

**Table 1: PGA309 Sensor Interface Board – Factory Jumper Settings**

## 6.2 PGA309 PC Interface Board – Factory Jumper Settings

Confirm and/or set the jumpers on the PGA309 PC Interface Board as shown in Figure 4. The desired jumper settings are also described in Table 2.

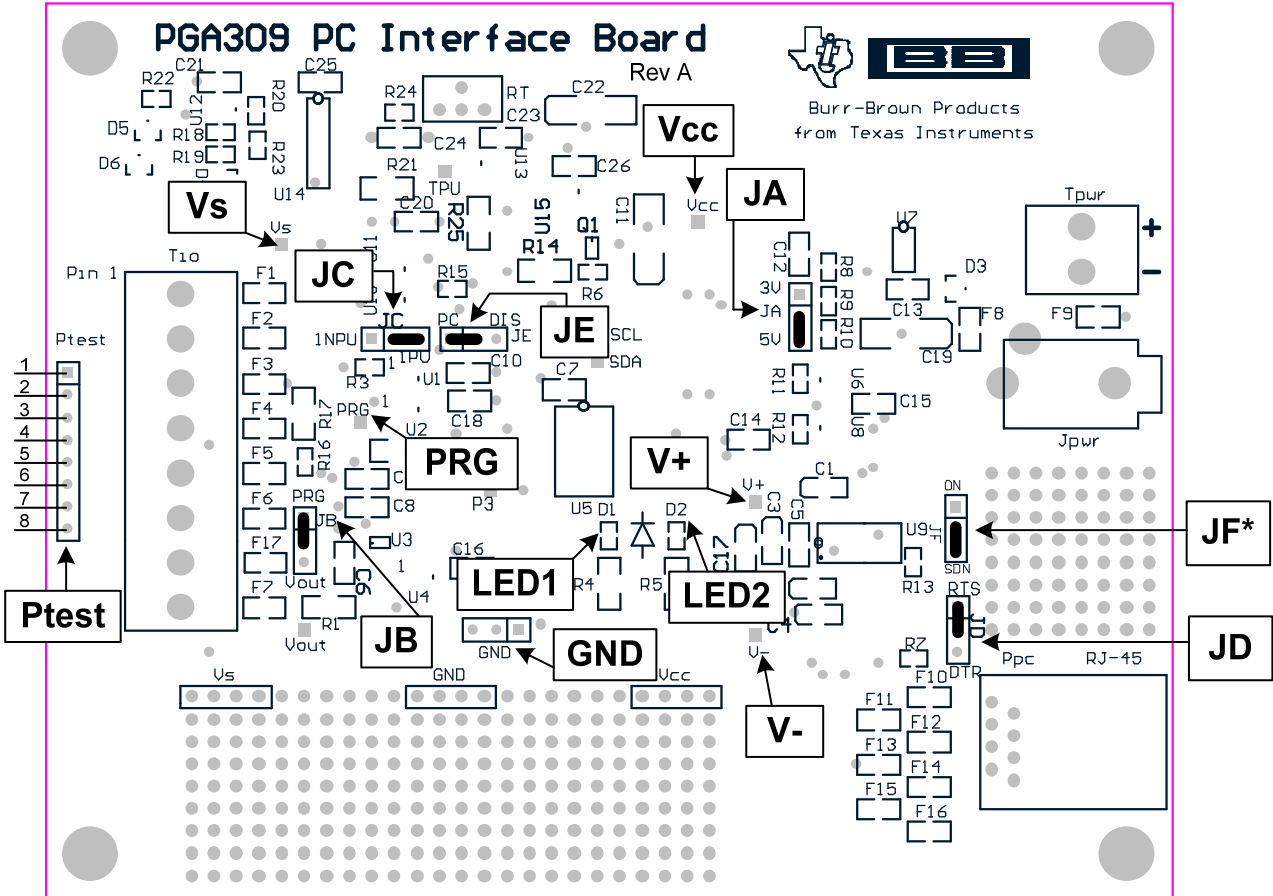

**\*Rev A Boards Only**

**Figure 4: PGA309 PC Interface Board – Factory Jumper Settings**

<b>PGA309 PC Interface Board – Factory Jumper Settings</b>		
<b>Jumper</b>	<b>Position</b>	
JA	5V	PGA309 operates at +5V
JB	PRG	PRG not connected to VOUT
JC	1PU	Dynamic One-Wire Pullup Enabled
JD	RTS	PC Serial Interface loopback set for CTS-RTS
JE	PC	Two-Wire Enable Control by PC
JF*	SDN	RS-232 Auto Shutdown Mode

**\*Rev A Boards Only**

**Table 2: PGA309 PC Interface Board – Factory Jumper Settings**

# Preliminary

## 6.3 Hardware Setup (see Figure 5)

Plug the PGA309 Sensor Interface Board into the PGA309 PC Interface Board. On the PGA309 PC Interface Board connect a 6Vdc (6Vdc-9Vdc) Lab Supply into Tpwr or an AC Wall Adapter (120Vac RMS, 60Hz in; 6Vdc, 200mA out - USA Shipments Only) into Jpwr. Connect the PGA309DK PC Cable from Ppc (RJ-45 jack) on the PGA309 PC Interface Board to an RS-232 serial port on the Test Computer.

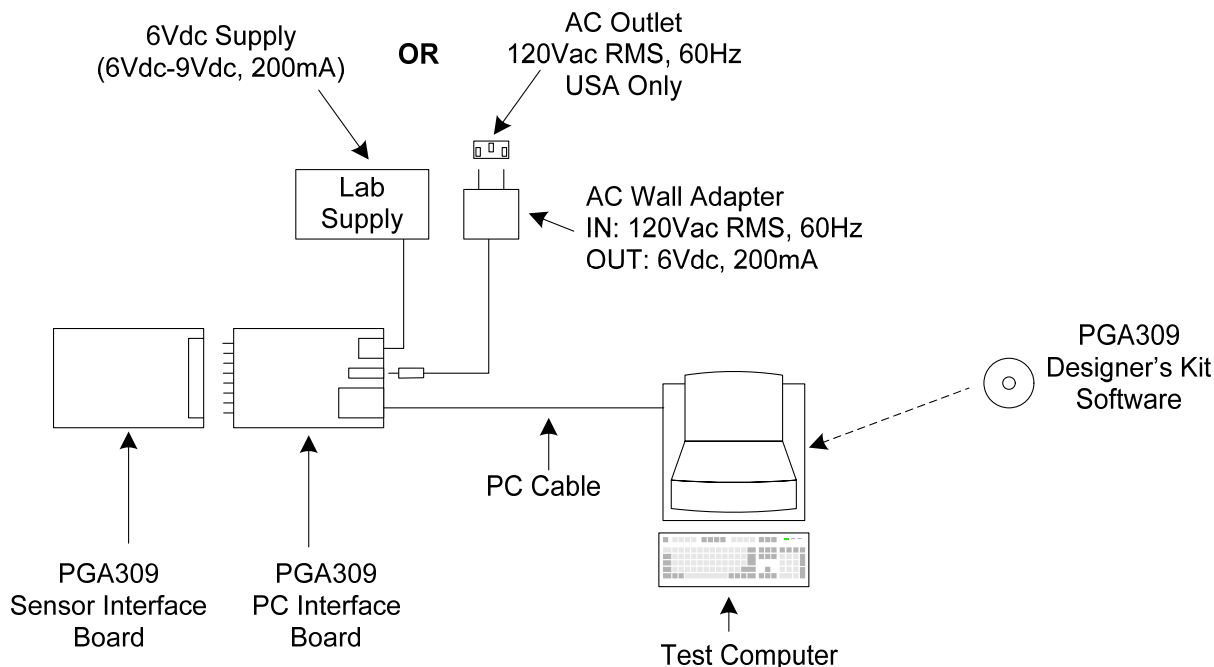

**Figure 5: Hardware Setup – Initial Checkout**

## 6.4 Board Control Software Installation

- 1) The PGA309Dk Board Control Software is installed in the normal Microsoft® Windows manner. Close all other applications. From “Start” button on the task-bar select “Run”.
- 2) In the Run Window type:  
d:\setup  
where “d” is the letter designation of the CD-ROM drive containing the PGA309DK Software CD-ROM.
- 3) Follow the on-screen prompts to install the software.
- 4) To remove the PGA309DK application use the Windows Control Panel utility “Add/Remove Software”.

## 6.5 Software/Hardware Initial Checkout

At this point no LEDs should be lit on the PGA309 PC Interface Board. If any LEDs are lit cycle the power on the PGA309 PC Interface Board.

# Preliminary

## 6.5.1 Software Startup

Start the PGA309DK Board Control Software by clicking on “PGA309 DK Board Interface” under the “Start” menu, “All Programs”, “PGA309 Designer’s Kit” as shown in Figure 6.

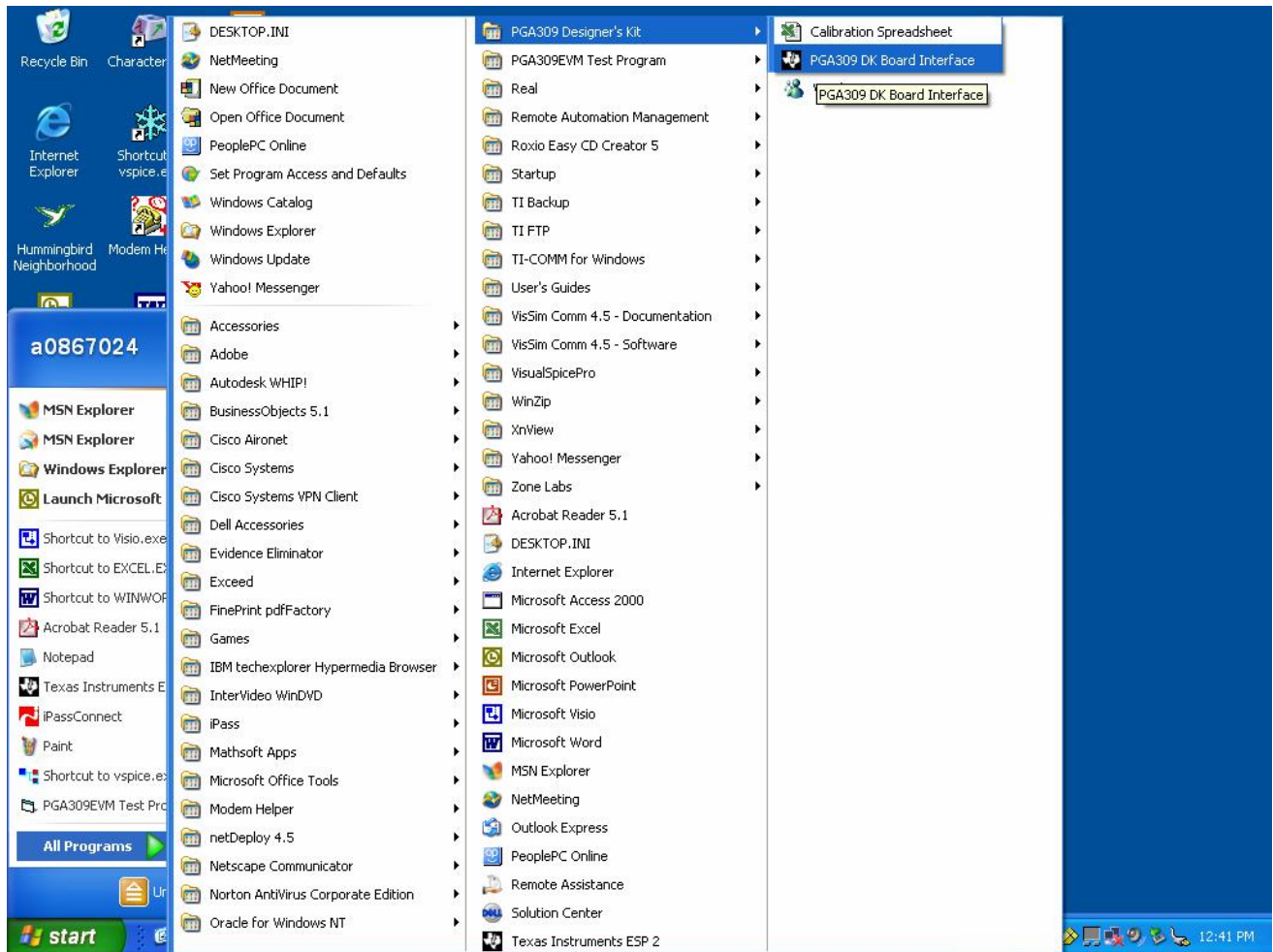

Figure 6: PGA309DK Board Control Software Startup

# Preliminary

## 6.5.2 Software Board Communication Setup – Default

On initial software startup a Main Window will appear with a smaller pop-up window in the middle of the Main Window. Click “Yes” on the pop-up window (see Figure 7). If the initial software startup does not look like Figure 7 then proceed directly to Section 6.5.3.

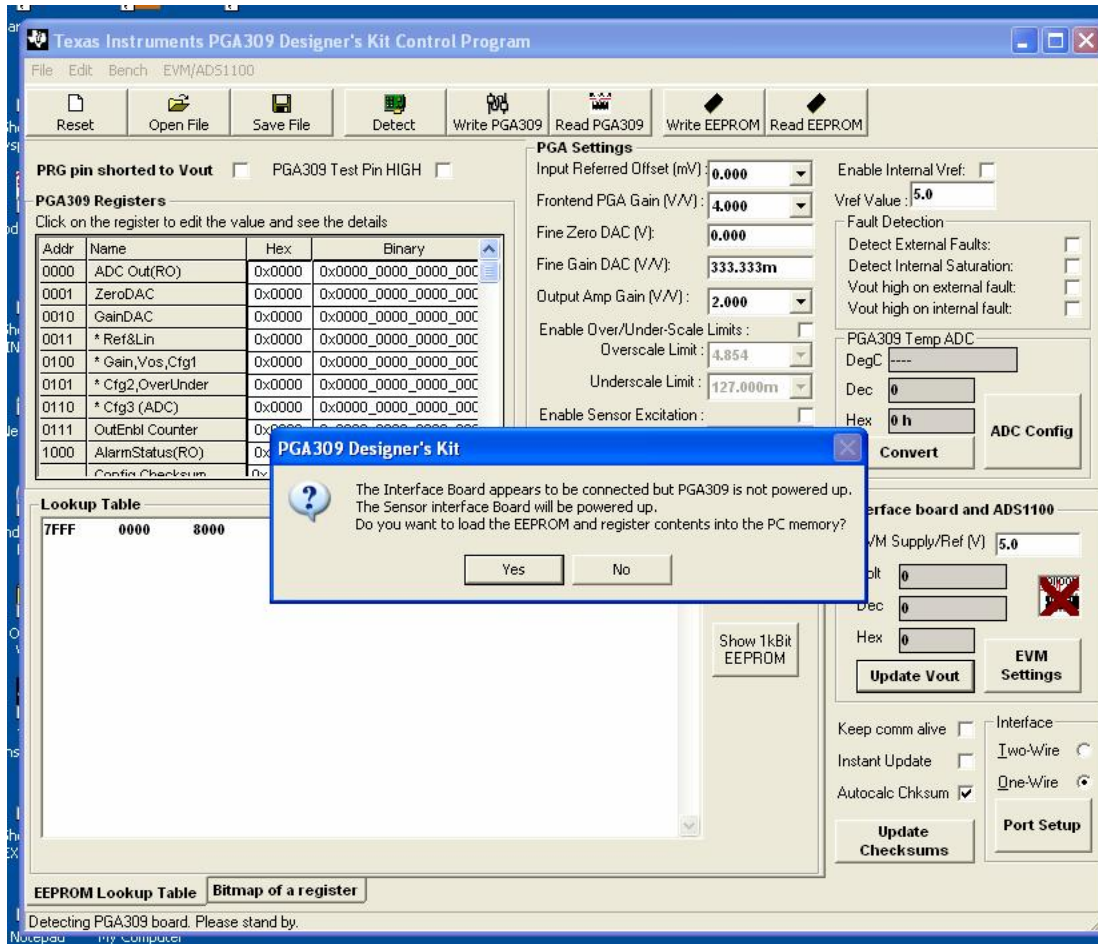

Figure 7: Software Startup – Main Window and First Pop-up Window

# Preliminary

The First Pop-Up Window will disappear and the Main Window should look as in Figure 8. If it does then proceed to Section 6.5.4 and skip Section 6.5.3.

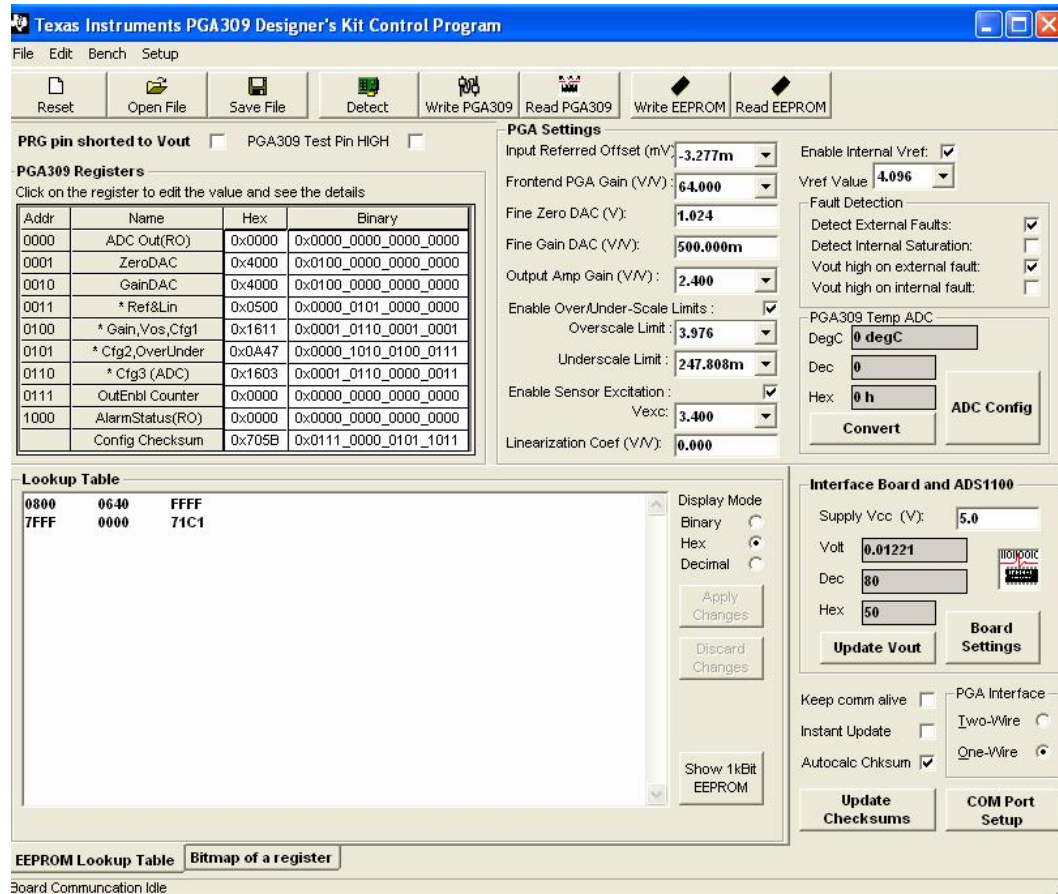

Figure 8: Software Startup – Main Window



# Preliminary

## 6.5.3 Software Board Communication Setup – Manual COM Port Setup

If on initial software startup the right Com port is not selected automatically then the first screen will look like Figure 9.

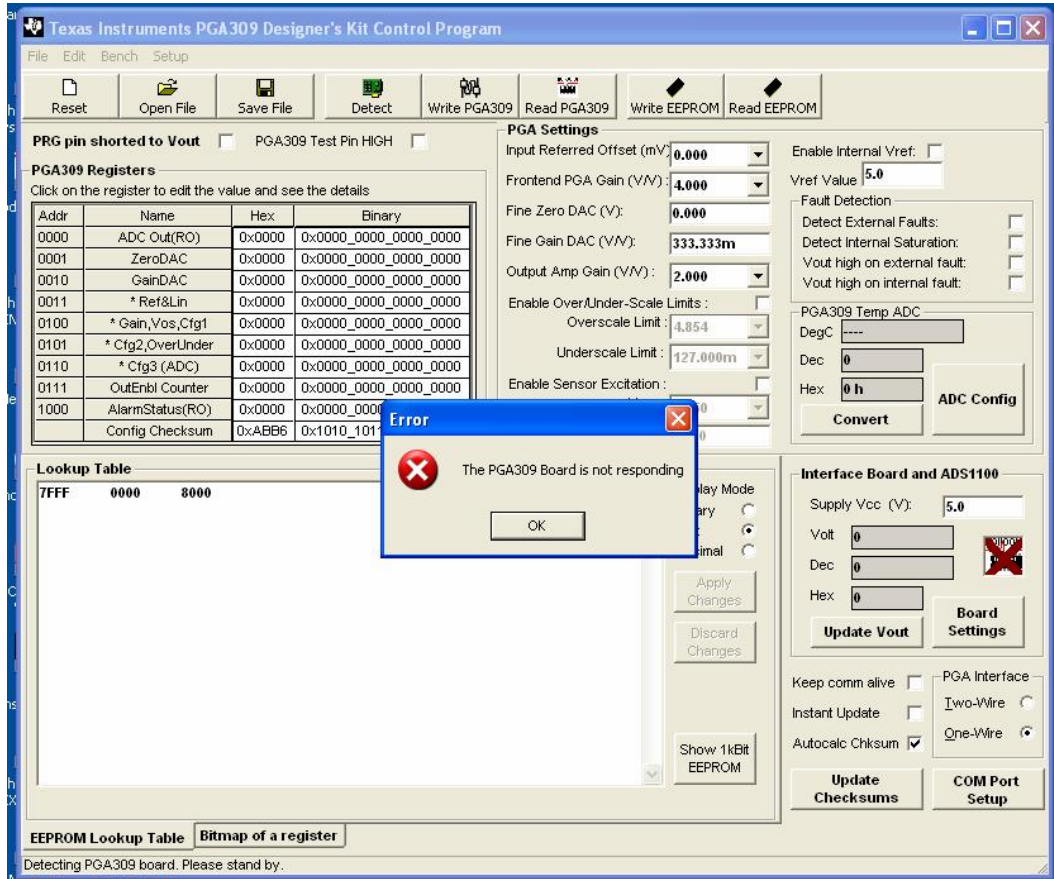

Figure 9: Software Startup – Wrong Com Port

Click on "OK" in the pop-up window in Figure 9. Then click on "COM Port Setup" in the Main Window. A new pop-up window will appear as in Figure 10. Select the serial port where the board is connected and desired Baud Rate and click "OK". Ensure "1Wire" Interface is selected.

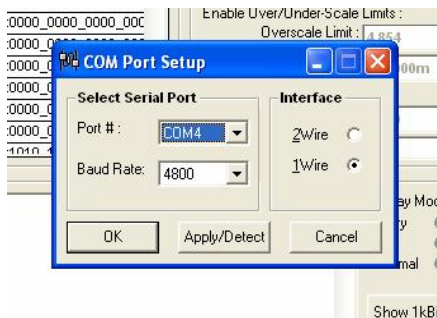

Figure 10: COM Port Pop-up Window

# Preliminary

Another pop-up window will appear as shown in Figure 11. Click “Yes” and the two pop-up windows should disappear with only the Main Window remaining as in Figure 8.

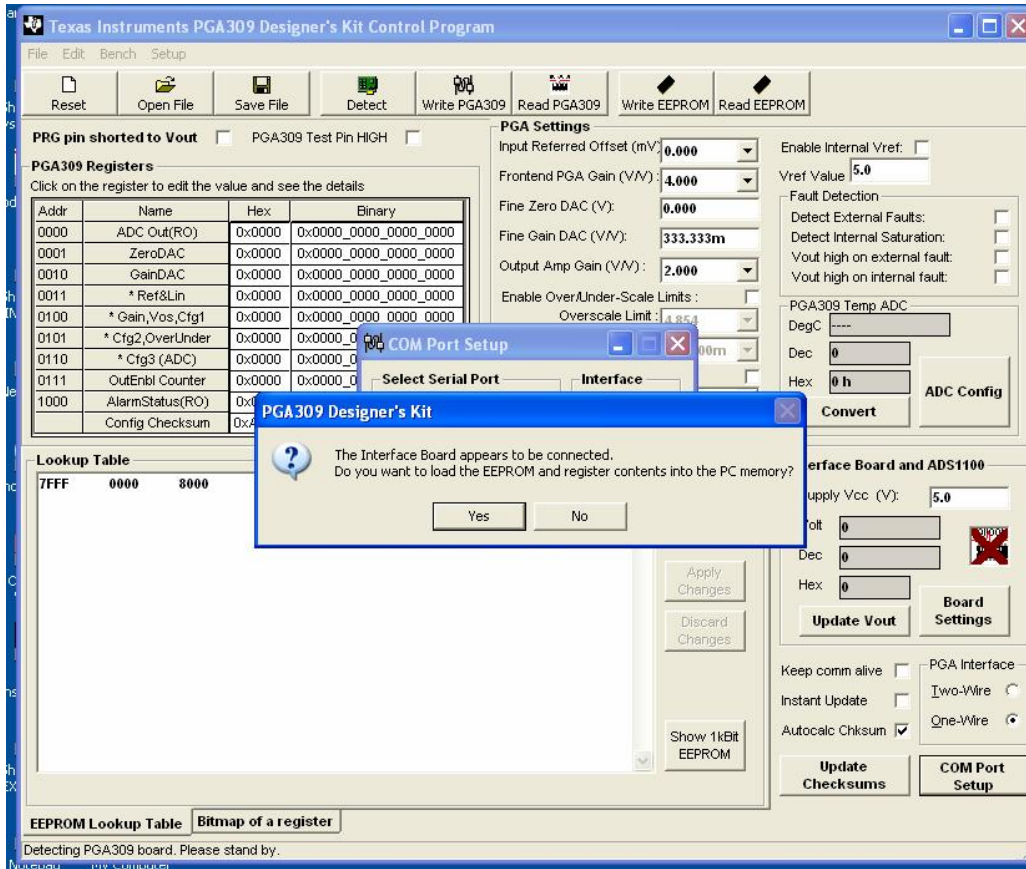

Figure 11: Communication Pop-up Window after COM Port Setup

## 6.5.4 Hardware Checkout

1) In the Main Window click on “Open File”. A pop-up window will appear as in Figure 12.

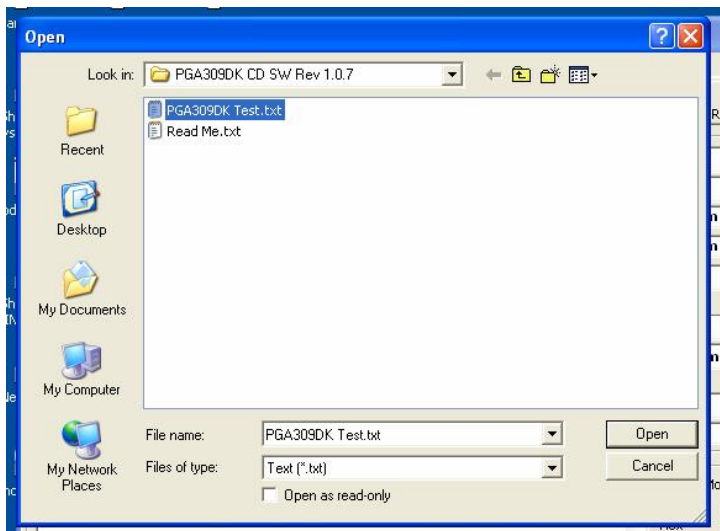

Figure 12: Open File Pop-up Window

# Preliminary

2) Select "PGA309DK Test.txt" and open this file (on the PGA309DK CDROM). A pop-up window will appear as in Figure 13. Click on "OK".



Figure 13: Open File Acknowledge Pop-up Window

The Main window will appear as in Figure 14.

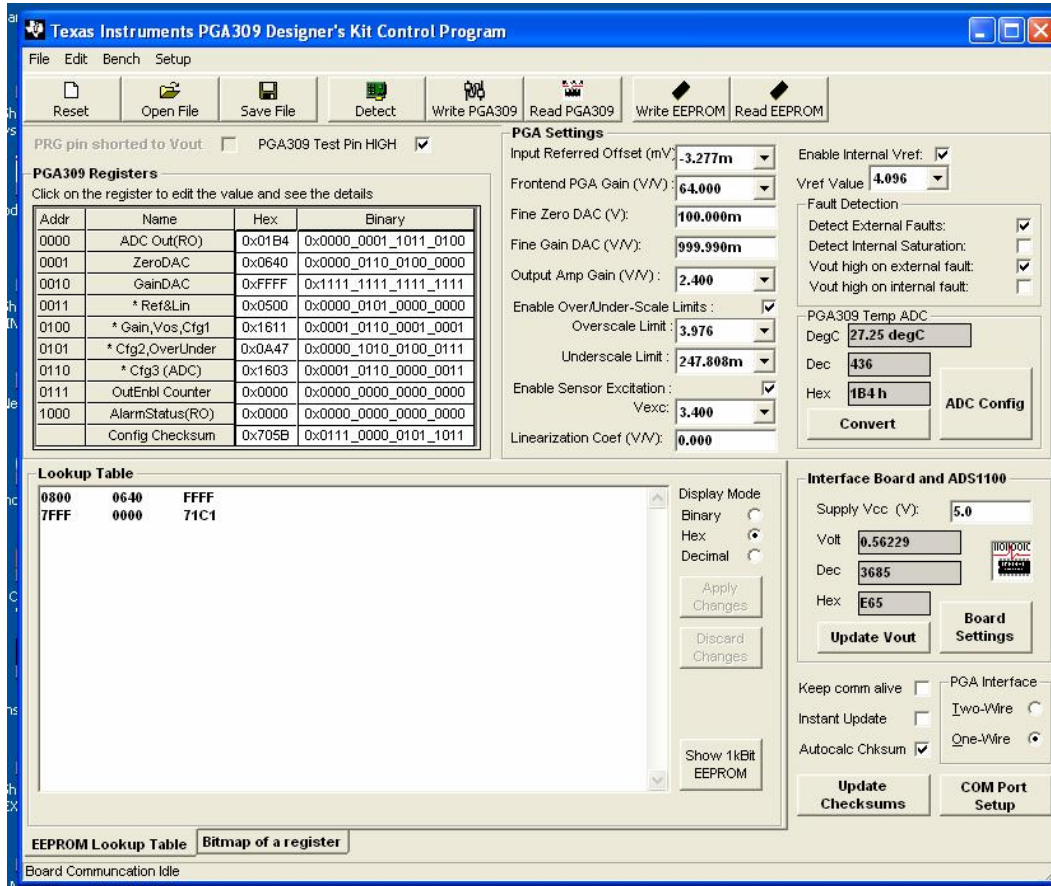

Figure 14: Main Window After Open File = "PGA309 Test.txt"

# Preliminary

Table 3 defines the PGA309 settings defined by this file (PGA309 Test.txt).

<b>Vref</b>	4.096	Internal
<b>Vexc</b>	3.4V	X0.83(Vref), Enabled
<b>Coarse Offset</b>	-3.277mV	
<b>Vdiff</b>	(0V-3.277mV) = -3.277mV	(33.67mV-3.277mV) = 30.393mV
<b>Vout</b>	-0.263V (ideal)	4.908V (ideal)
<b>PGA Gain</b>	X64	
<b>Fine Gain</b>	X1	
<b>Out Amp Gain</b>	X2.4	
<b>Zero DAC</b>	100mV	
<b>Over-Scale</b>	3.976V (ideal)	000 (0.9708 Vref)
<b>Under-Scale</b>	0.248V (ideal)	111 (0.06054 Vref)
<b>Fault Detect</b>	EXTEN=1	Enable External Fault Comparator Group
	INTEN=0	Disable Internal Fault Comparator Group
	OJEN=1	Enable Over/Under-Scale Limits

**Table 3: PGA309DK Sensor Interface Board Functional Test Settings**

- Write these settings to the PGA309 Sensor Interface Board EEPROM by clicking on "Write EEPROM" in the Main Window. Click on "Read EEPROM" and then click on "Read PGA309". The Main Window should look the same as in Figure 14 .
- Configure ADS1100 for continuous readback. In the Main Window click on "Board Settings". The Status Window ("ADS1100 and PCF8574A Status" Window) will appear as in Figure 15.

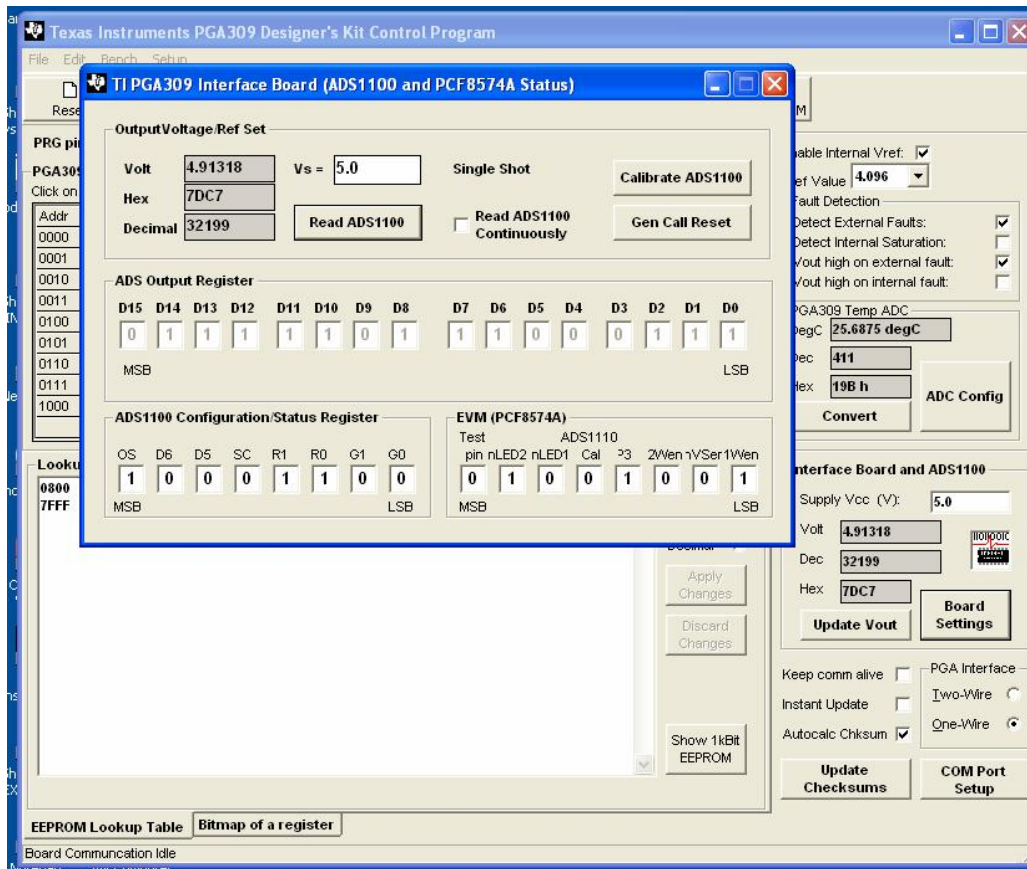

**Figure 15: Status Window**

## Preliminary

- 5) In the Status Window check the box to "Read ADS1100 Continuously".
- 6) In the Main Window set "Supply Vcc (V)" to 5.0V
- 7) The "Rtest" potentiometer and "J4" on the PGA309 Sensor Interface Board will be used for this test. On the PGA309 PC Interface Board the ADS1100 ADC will be used for this test. Table 4 below details the actions and acceptable results for a pass condition of the PGA309 Sensor Interface and PGA309 PC Interface Boards.

Step	Rtest	J4 Position	ADS1100 read (Volts min)	ADS1100 read (Volts max)
1	Rotate Fully Clockwise (until audible clicking is heard)	Vexc	0.19	0.26
2	Rotate Fully Counter-Clockwise (until audible clicking is heard)	Vexc	3.9	4.1
3	Don't Care	Open	4.9	5.0
4	Replace J4	Vexc	Don't Care	Don't Care

**Table 4: Hardware Checkout Voltages and Settings**

- 8) In the Main Window, under "PGA309 Temp ADC", click on "Convert" (see Figure 16).
- 9) Temperature reading in °C should be the PGA309 ambient +/-2°C. Readout will be in Main Window under "PGA309 Temp ADC" section as shown in Figure 16.

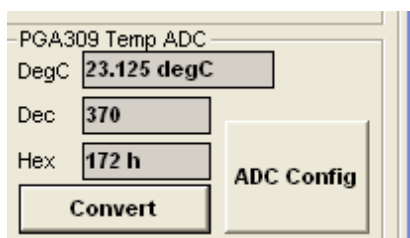

**Figure 16: Internal Temperature Reading**

If all steps above, in Section 6, have been successfully completed then the PGA309 Sensor Interface Board, PGA309 PC Interface Board, PC Cable, PGA309DK Board Control Software are all operating correctly.

# Preliminary

## 7.0 Board Control Software Overview

Figure 17 depicts the Main Window for the Board Control Software. Subsections of the Main Window (outlined by dashed lines) as well as the “Top Row Control Buttons” and “Board Communication Status” will be described in detail in sections 7.1-7.10.

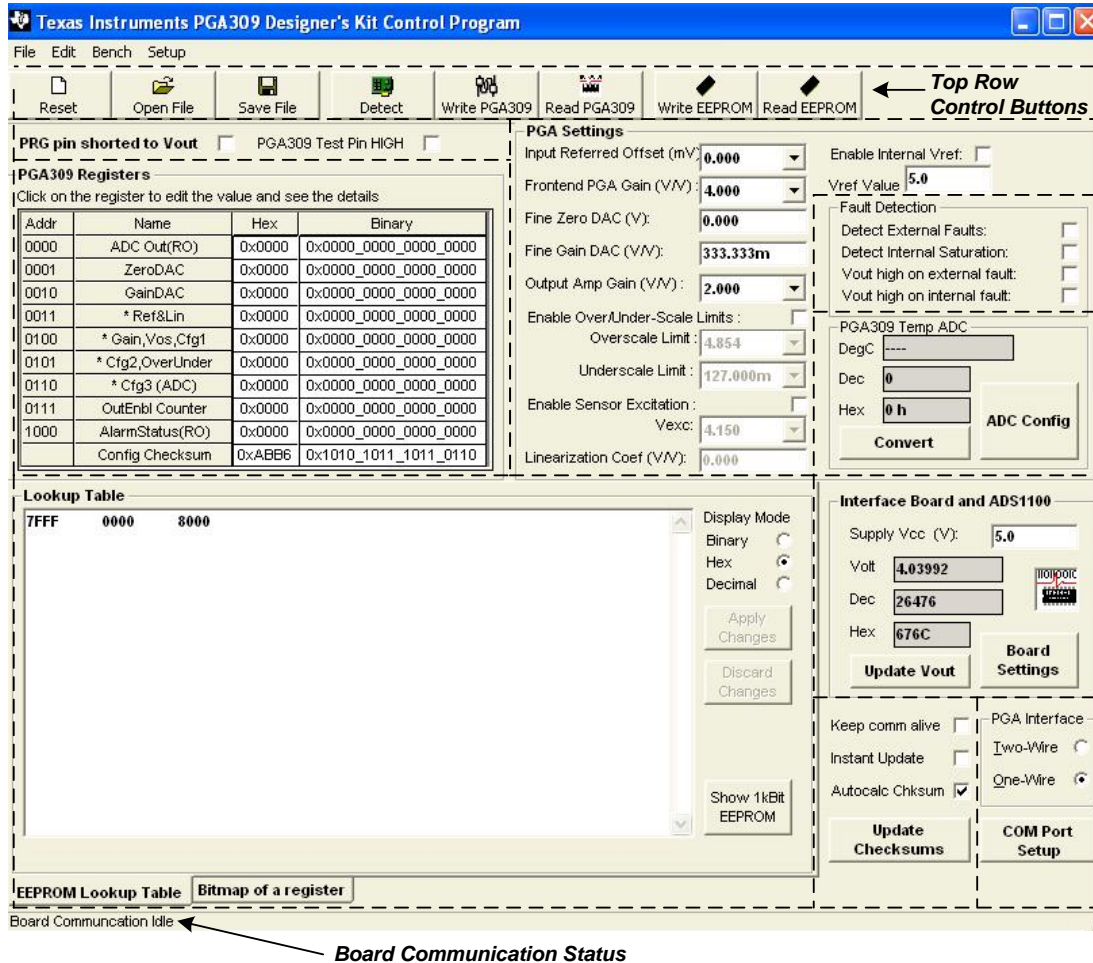

Figure 17: Main Window

# Preliminary

## 7.1 Top Row Control Buttons

The “Top Row Control Buttons” are described in Table 5.

Button Name	Description	Comments	See Related Figure ?
Reset	Resets all register bit values to zero	Resets values in PC memory only. Requires a “Write to PGA” or “Write to EEPROM” to effect	
Open File	Selects File to open which contains saved EEPROM Configuration Register and Lookup Table values.		Figure 18
Save File	Selects File to save current EEPROM Configuration Register and Lookup Table values.		Figure 18
Detect	Looks for PGA309DK Boards using current “Port Setup”. Configures the board and read the current Register and the Lookup Table values	Both PGA309 Sensor Interface and PGA309 PC Interface must be present and working.	
Write PGA309	Writes all current Main Window values into PGA309 R/W Registers (including setting ZeroDAC and GainDAC).	Unless Test Pin is set high these settings will be overwritten by valid external EEPROM data.	
Read PGA309	Reads all current PGA309 Register values into the Main Window.		
Write EEPROM	Writes current values in the Lookup Table section and PGA309 Register section of the Main Window into external PGA309 EEPROM.		
Read EEPROM	Reads external PGA309 EEPROM values into Main Window.		

**Table 5: Main Window - Top Row Control Buttons**

### 7.1.1 General Note on Reading & Writing to PGA309 and External EEPROM:

When you do a “Write EEPROM” whatever is in the “Main Window” will be written to the PGA309 external EEPROM **EXCEPT** for the Zero DAC and Gain DAC values in the “PGA Settings” section of the “Main Window”. However, in the case of the Zero DAC and the Gain DAC it does not make any sense to write to the EEPROM the settings in the section “PGA Settings” since the Zero DAC and Gain DAC settings can be many values as defined by the Lookup section of the EEPROM. **To write Zero DAC and Gain DAC settings into EEPROM you must update or change the “Lookup Table” section in the “Main Window”. Also if you type a number into the Zero DAC or Gain DAC boxes in the “PGA Settings” section of the “Main Window” and then do a “EEPROM Read” the previously typed numbers will remain. To read the current Gain DAC and Zero DAC settings of the PGA309 internal registers and have them updated and displayed in the “PGA Settings” section of the Main Window click on the “Read PGA309” Button.**

If you want to try different settings on the PGA309 then it is best to check the box “PGA309 Test Pin High” in the upper middle area of the “Main Window” which stops the PGA309 from reading the EEPROM and allows you to “Write PGA309” which will directly change (but **NOT** save to EEPROM) the Zero DAC and Gain DAC settings for trial offset and gain settings, etc.

# Preliminary

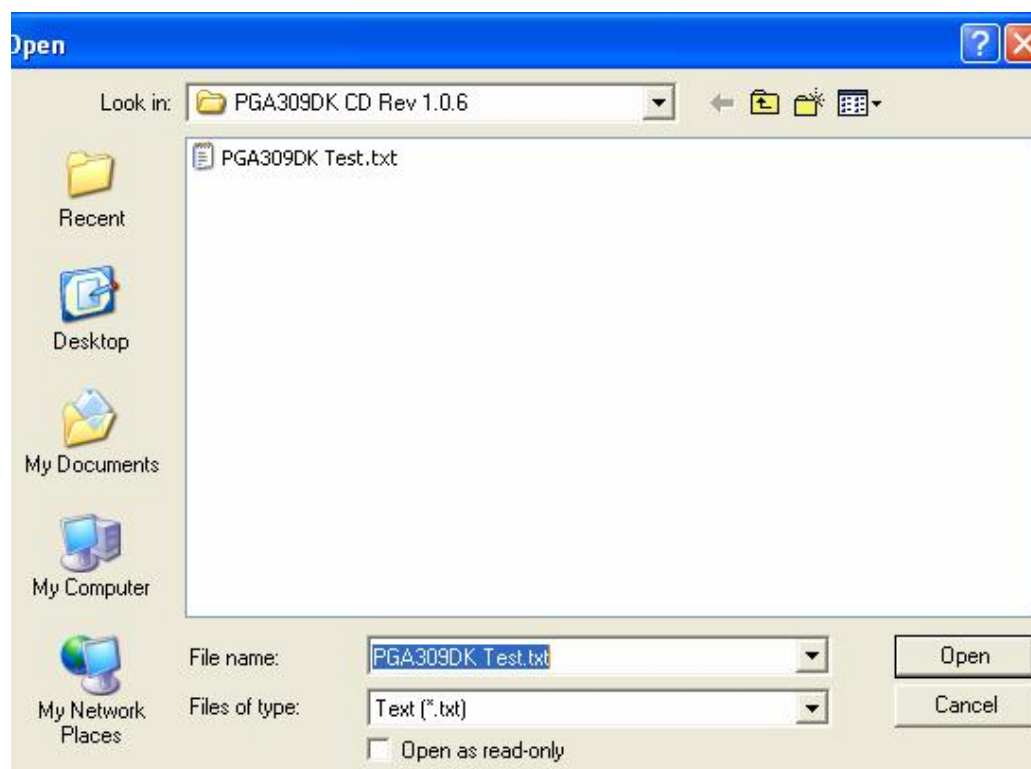

Figure 18: Typical Write PGA309 or Read PGA309 Pop-up Window

## 7.2 EEPROM Lookup Table

When the “EEPROM Lookup Table” is selected on the bottom Tab in the Main Window the Temperature Coefficients stored in the PGA309 external EEPROM from the last “Read EEPROM” are displayed in the “Lookup Table” section of the Main Window. These values can be displayed by selecting the desired format as Binary, Hex or Decimal under “Display Mode” in the “Lookup Table” section. See Figure 17. If the entire contents of the EEPROM is to be viewed or edited, in Hex and ASCII only, then click on “Show 1kBit EEPROM” in the “Lookup Table” section of the Main Window. Figure 16 shows the resultant pop-up window which displays the entire external PGA309 EEPROM contents in Hex. Remember the EEPROM contents are mapped **least significant byte first** relative to PGA309 16-Bit registers as shown in Figure 20.

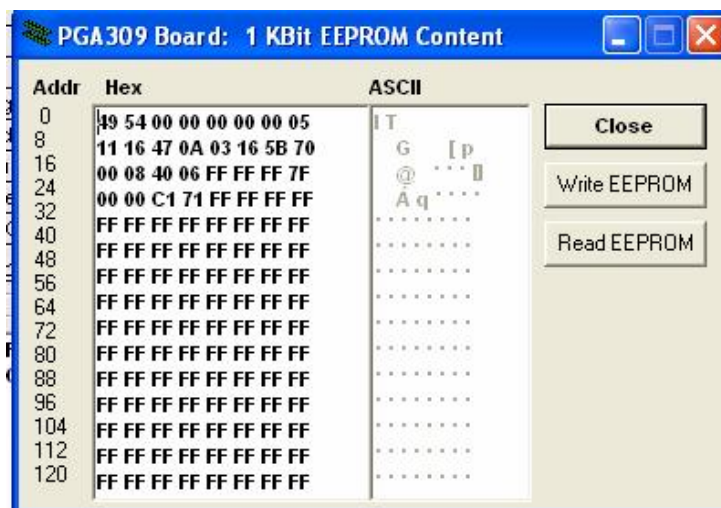
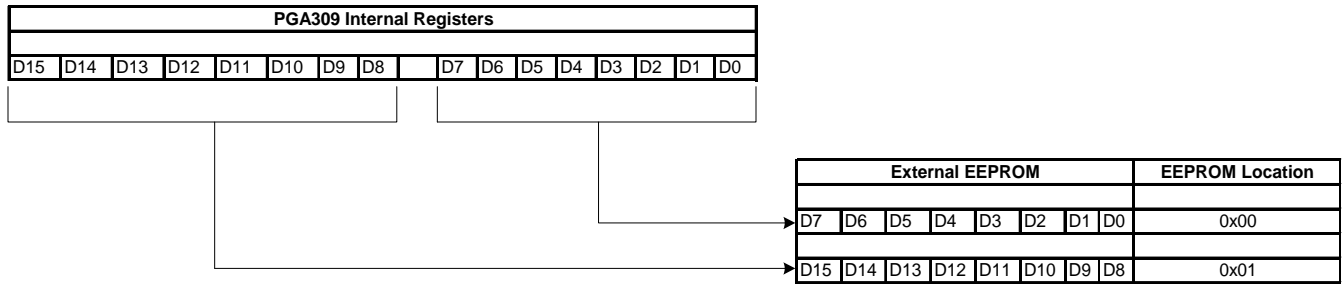

Figure 19: PGA309 External EEPROM Pop-up Window



# Preliminary



**Figure 20: PGA309 Internal Registers to PGA309 External EEPROM Mapping**

For updating the information in the “EEPROM Lookup Table” section simple click and edit the desired values. Next click on the “Apply Changes” button in the “EEPROM Lookup Table” section. This only updates the information for the Lookup Table information stored on the Test PC. If these new values are desired to be written into the external EEPROM, then after the “Apply Changes” click one must click on the “Write EEPROM” button at the top of the Main Window. If the changes edited in the Lookup Table are desired not to be kept on the Test PC then click on “Discard Changes” and the last values in the Lookup Table stored on the Test PC will be restored.

The other way to directly write to the external EEPROM is through the “PGA309 External EEPROM Pop-up Window” as shown in Figure 19 and discussed above.

### 7.3 PGA309 Registers

The PGA309 current internal register contents are displayed in the “PGA309 Registers” section of the Main Window. By clicking on the “Bitmap of a register” tab in the bottom left corner of the Main Window the Main Window view will change to that of Figure 21. The lower left quadrant of the Main Window now displays detailed information about the PGA309 register selected by clicking on a specific register listed in the “PGA309 Registers” section of the Main Window. Each bit in the selected register may be toggled by double-clicking on the desired current bit setting. A brief description of each bit also appears. If the “Instant Update” check-box in the lower right of the Main Window is not checked than the “Write PGA309” button will need to be pushed. Remember if you do not want the register settings in the PGA309 to be over-written by valid PGA309 external EEPROM data then ensure the PGA309 Test pin is set high by checking the “PGA309 Test Pin HIGH” box in the upper left area of the Main Window.

# Preliminary

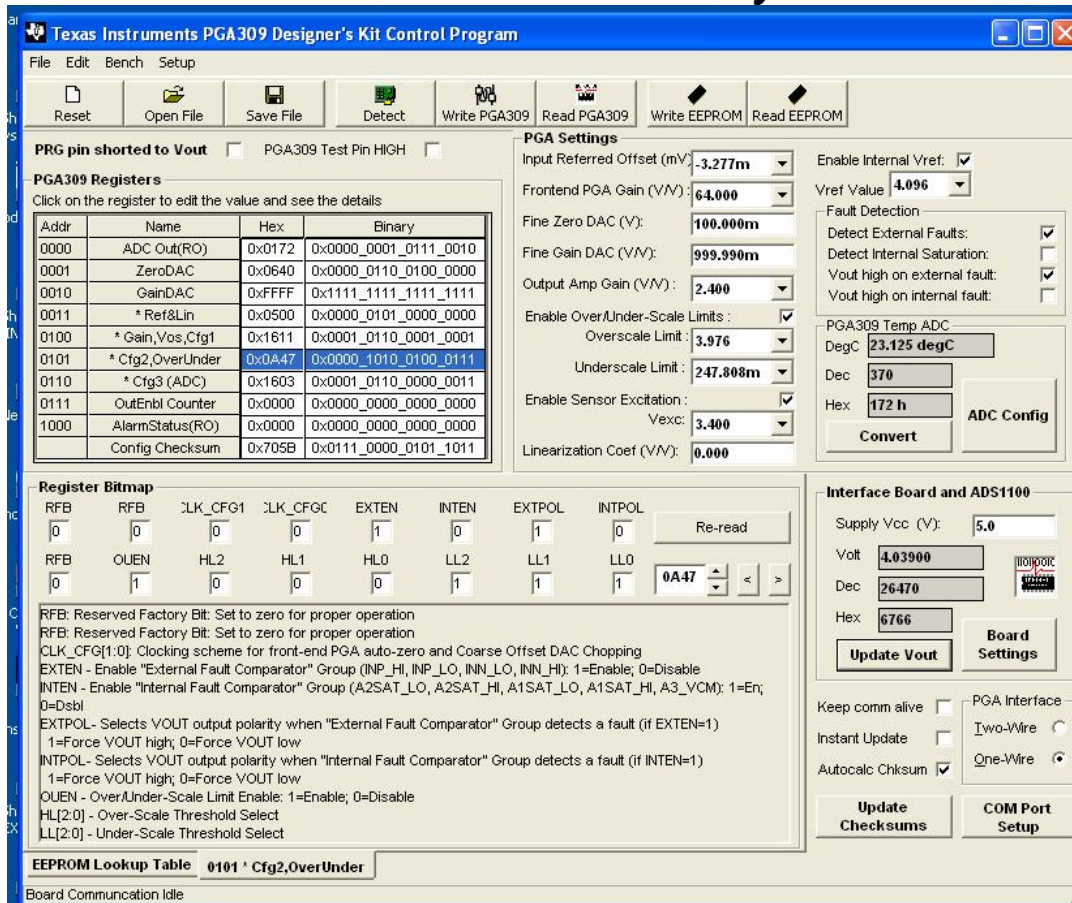

Figure 21: PGA309 Registers – Main Window

## 7.4 PGA Settings

Rather than toggling individual bits of the registers described above, the PGA309 can be configured using drop-down menu selections or check-boxes in the “PGA Settings” section of the Main Window contains:

- Input Referred Offset (mV)
- Frontend PGA Gain (V/V)
- Fine Zero DAC (V)
- Fine Gain DAC (V/V)
- Output Amplifier (V/V)
- Enable Over/Under-Scale Limits
- Overscale Limit
- Underscale Limit
- Enable Sensor Excitation
- Linearization Coef (V/V)
- Enable Internal Vref
- Vref Value

Changing these settings will update the corresponding bits of in the register table and vice versa. The current values of these and the PGA309 registers will be automatically updated in the Main Window following a “Read PGA309”. The current settings displayed in the Main Window will be written to the PGA309 internal registers following a “Write PGA309” or to the external PGA309 EEPROM following a “Write EEPROM”. If the “Instant Update” check-box in the lower right of the Main Window is checked then the PGA309 internal registers will automatically be updated after every change. Remember if you do not want the register settings in the PGA309 to be over-written by valid PGA309 external EEPROM data then ensure the PGA309 Test pin is set high by checking the “PGA309 Test Pin HIGH” box in the upper left area of the Main Window.

# Preliminary

## 7.5 Fault Detection

In the "Fault Detection" section of the Main Window the following check-boxes are provided for fault detection configuration:

- Detect External Faults (checked means enable detection of external faults)
- Detect Internal Faults (checked means enable detection of internal faults)
- Vout high on external fault (unchecked means Vout low on external fault)
- Vout high on internal fault (unchecked means Vout low on internal fault)

The current settings of these in the PGA309 registers will be automatically updated in the Main Window following a "Read PGA309". The current settings displayed in the Main Window will be written to the PGA309 internal registers following a "Write PGA309" or to the external PGA309 EEPROM following a "Write EEPROM". If the "Instant Update" check-box in the lower right of the Main Window is checked then the PGA309 internal registers will automatically be updated. Remember if you do not want the register settings in the PGA309 to be over-written by valid PGA309 external EEPROM data then ensure the PGA309 Test pin is set high by checking the "PGA309 Test Pin HIGH" box in the upper left area of the Main Window.

## 7.6 PGA309 Temp ADC

In the "PGA309 Temp ADC" section of the Main Window the current Temp ADC reading will be displayed if the "Convert" button is pushed. If a continuous update of the Temp ADC contents is desired it can be read and updated about every 0.75 second by checking the box labeled "Keep Comm Alive" in the lower right corner of the Main Window. Please note that this will also prevent the 1s timeout in the PGA309 from expiring thus stopping EEPROM read-back updates even if Test Pin is low.

By clicking on the "ADC Config" button a pop-up window will be displayed as shown in Figure 22. The flexible Temp ADC can be configured as desired for the application. For details of the Temp ADC options and settings see the PGA309 Data Sheet. If the settings are changed and to be applied then click "OK" in the pop-up window. Remember if you do not want the register settings in the PGA309 to be over-written by valid PGA309 external EEPROM data then ensure the PGA309 Test pin is set high by checking the "PGA309 Test Pin HIGH" box in the upper left area of the Main Window. If these changes are to be included in the EEPROM then set the Test pin HIGH while configuring the Temp ADC, then "Write EEPROM" then set Test pin low for continuous EEPROM reads by the PGA309 with the new Temp ADC settings.

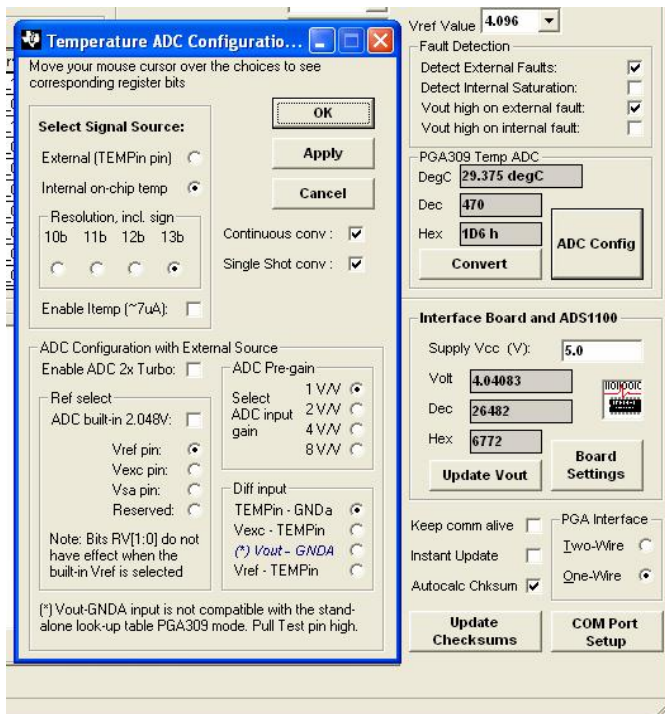

Figure 22: PGA309 Temp ADC Configuration & Readback

# Preliminary

## 7.7 Interface Board and ADS1100

In the “Interface Board and ADS1100” section, in the Main Window, click on “Board Settings”. A pop-up window will appear as in Figure 23. This pop-up window provides configuration control of the ADS1100 and the Port Expander, PCF8574A.

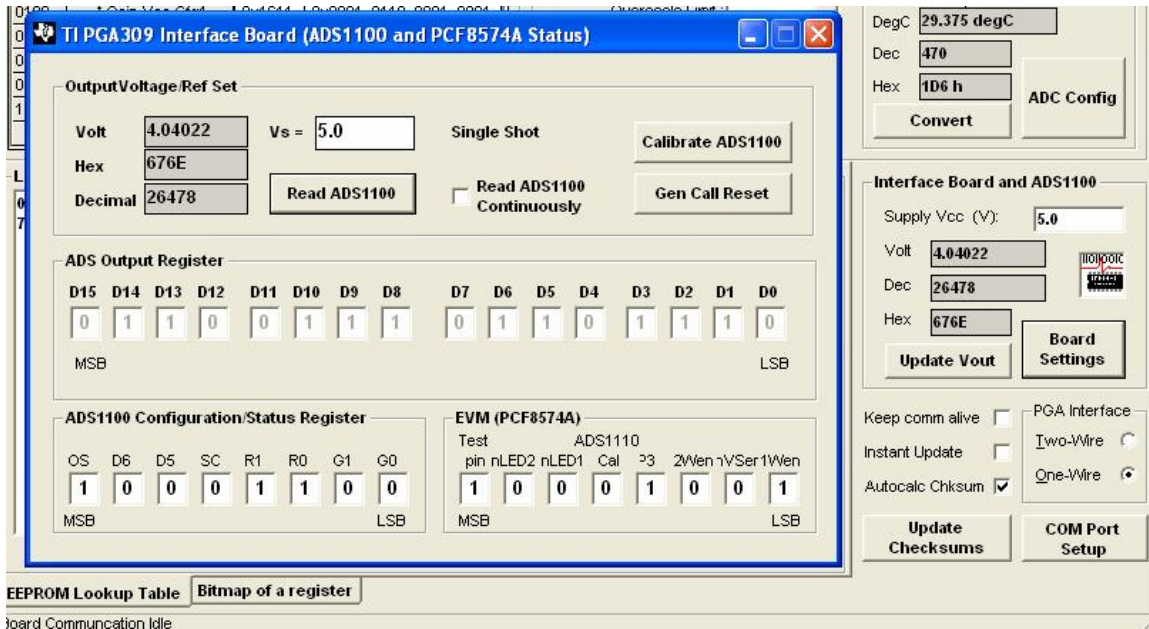

Figure 23: “ADS1100 and PCF8574A Status” Window

In the pop-up window the bits under “EVM (PCF8574A)” will toggle when single-clicked. Table 6 describes the use of each of these bits.

If the “Calibrate ADS1100” Button is pushed it will short the two inputs of the ADS1100 together and compute the offset error. All ADS1100 readings which follow will be calibrated to account for this offset error. In addition measure the voltage  $V_s$  on the PGA309 PC Interface Board with an accurate meter and enter this voltage in the “Supply Vcc (V)” box in the Main Window or enter this voltage into the “ $V_s$ =” box in the pop-up window. After these two ADS1100 calibration steps are complete the ADS1100 is fully calibrated for both gain and offset errors. Each time the “Calibrate ADS1100” Button is pushed a new ADS1100 offset calibration is performed and the subsequent readings will use the latest calibration numbers.

If the “Read ADS1100” button is pushed a single conversion will be performed in the ADS1100. The reading will be updated in both the Main Window and in the pop-up window. If the box labeled “Read ADS1100 Continuously” is checked then both the pop-up window and Main Window ADS1100 readings will be updated about every 2 seconds depending upon the operating system conditions.

The “ADS Output Register” section in the pop-up window is a read-only bit readout of the latest ADS1100 conversion.

The “ADS1100 Configuration Status Register” bits allow for custom configuration of the ADS1100. These bits are toggled by a one-click method in the corresponding box. The default setting is 0x8C. This configures the ADS1100 for Continuous Conversion Mode, Internal PGA= $\times 1$ , and 8 samples per second data rate. If these settings are changed they can be returned to the initial power-up settings by pushing the “Gen Call Reset” in the pop-up window. If the Vcc voltage on the PGA309 PC Interface Board is changed then the ADS1100 will need to be re-calibrated for gain and offset (this assumes Vcc will become the  $V_s$  for the PGA309 Sensor Interface Board). For further ADS1100 details consult the ADS1100 data sheet.

## Preliminary

	<b>Logic State</b>	<b>Description</b>	<b>Comments</b>
<b>P7 Test pin</b>	<b>0</b>	PGA309 operates in "Normal / Stand-Alone Mode".	Reads external EEPROM and uses temperature coefficients to update Gain DAC and Zero DAC settings.
	1	PGA309 operates in "Test Mode".	No external EEPROM reads and must be manually written to for changes in DACs or register settings.
<b>P6 nLED2</b>	<b>0</b>	Turns on LED D2 on PGA309 PC Interface Board.	LED D2 is turned on by the Board Control Software if "PGA309 Test Pin HIGH" box in the Main Window is checked.
	1	Turns off LED D2 on PGA309 PC Interface Board.	LED D2 is turned off by the Board Control Software if "PGA309 Test Pin HIGH" box in the Main Window is not checked.
<b>P5 nLED1</b>	<b>0</b>	Turns on LED D1 on PGA309 PC Interface Board.	LED D1 is turned on by the Board Control Software when successful communication has been completed after power-on from zero volts on the PC Interface Board.
	1	Turns off LED D1 on PGA309 PC Interface Board.	
<b>P4 ADS1100 Cal</b>	<b>0</b>	Normal ADS1100 input operation.	
	1	Shorts ADS1100 inputs ( $V_{IN+}$ and $V_{IN-}$ ) together for offset calibration.	Used in the ADS1100 calibration sequence by the Board Control Program
<b>P3</b>	<b>0</b>	Logic output of port expander port P3, PGA309 PC Interface Board, U5, pin 7.	Spare port expander port available for user application if desired.
	1		
<b>P2 2WEN</b>	<b>0</b>	Disables the Two-Wire interface from the PGA309 Sensor Interface Board.	To allow reliable, uninterrupted connection to ADS1100 and PCF8574A when PGA309 is in Stand-Alone Mode set this bit to zero.
	1	Enables the Two-Wire interface from the PGA309 Sensor Interface Board.	To allow for Two-Wire digital communication from PC to PGA309 and external EEPROM.
<b>P1 nVSen</b>	<b>0</b>	Applies $V_s$ to PGA309 Sensor Interface Board.	Important when PRG is connected to $V_{out}$ on PGA309 to ensure One-Wire communication during power-up.
	1	Removes $V_s$ from PGA309 Sensor Interface Board.	Important when PRG is connected to $V_{out}$ on PGA309 to ensure One-Wire communication during power-up.
<b>P0 1Wen</b>	<b>0</b>	Disable 4.7k $\Omega$ One-Wire pull-up resistor.	Important to disable for unloaded PGA309 $V_{out}$ accurate reading through ADS1100.
	1	Enable 4.7k $\Omega$ One-Wire pull-up resistor.	

**Table 6: Functionality of Port Expander (PCF8574A) Bits  
(default initial values selected by the Board Control Software are highlighted in bold)**

# Preliminary

## 7.8 Interface

The “Interface” section in the Main Window allows for selection of One-Wire or Two-Wire digital communication with the PGA309 Sensor Interface Board. Refer to Figure 24. A single click in the respective circle will select the desired interface. All Board Control Software functionality is supported over either of these interfaces, however the One-Wire interface is the preferred one due to potential conflicts arising from two Two-Wire masters (PC and PGA309) sharing the bus. It is recommended to have PRG wire connected on the PGA309 Sensor Board even when using Two Wire communication. The Board Control Software addresses PGA309 using One-Wire interface prior to closing the switches U10/U11. ***This stops any activity by the PGA309 on the Two-Wire interface for 1 second and prevents any bus conflicts.*** By pushing the “COM Port Setup” button a pop-up “COM Port Setup” window will appear in the Main Window. In the pop-up window the desired interface may also be selected as well as which PC COM port (“Port #”) will be used and the Baud Rate (“Baud Rate”) for Communication through the selected COM Port. Drop-down menus are used to select both the desired COM Port and Baud Rate. Once the interface is selected it may be tested by pushing the “Apply/Detect” button or by pushing the “OK” button, in the pop-up window.

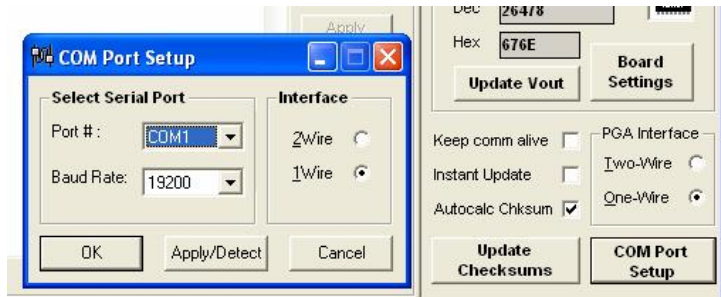

Figure 24: Interface Section and COM Port Setup Pop-up Window

## 7.9 Updates

The “Updates” section (see Figure 25) in the Main Window provides options for how certain calculations and readings in the Main Window are updated. If the “Autocalc Chksum” box is checked then both the configuration register part checksum (Checksum1) and the temperature coefficient part checksum (Checksum2) for the external EEPROM are computed automatically after every change. If the box is not checked then the calculations of the checksums may be manually accomplished by pushing the “Update Checksums” button or entering the checksum values directly from hand calculation.

The “Keep comm alive” box, when checked, reads the Temp ADC register and updates the Main Window reading about every 0.75 second, depending upon the operating system used. This will prevent the 1s timeout in the PGA309 from expiring thus stopping EEPROM read-back updates even if Test Pin is set low.

The “Instant Update” box, when checked, updates the PGA309 Registers immediately after every bit change without having to push the “Write PGA309” button. Remember that unless Test pin is set high these settings will be overwritten by valid external EEPROM data.

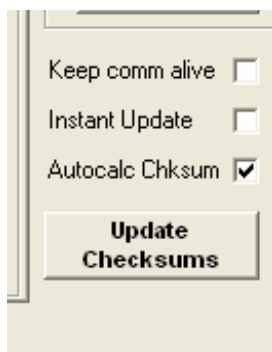

Figure 25: Updates Section

# Preliminary

## 7.9 Board Communication Status

The “Board Communication Status” section (see Figure 26) is located in the bottom left corner of the Main Window. When reads or write to the PGA309 internal registers or PGA309 external EEPROM are executed messages will appear in this window as confirmation that the communication is taking place successfully.

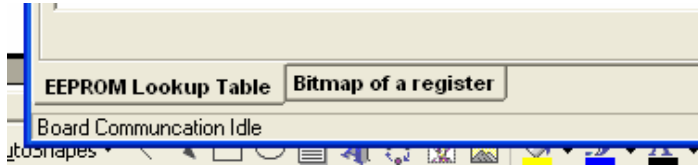

Figure 26: “Board Communication Status” Section

## 7.10 Miscellaneous Main Window Boxes

In the upper left corner of the Main Window, under the “Top Row Control Buttons”, there are two check boxes as shown in Figure 27.

“PGA309 Test Pin High” if checked will put a logic high on the Test pin. See Table 6 for the description of the Test pin function. LED D2 on the PGA309 PC Interface Board will be lit whenever this box is checked (Logic High).

If the PGA309 is to be configured with its PRG pin tied to Vout then the box labeled “PRG pin shorted to Vout” (see Figure 27) must be checked for reliable operation. With this box checked the Board Control Software will cycle power on the PGA309 each time it tries to communicate with PGA309 over One Wire interface to ensure that Vout is in high impedance on the PGA309 during the first 25ms after power up.

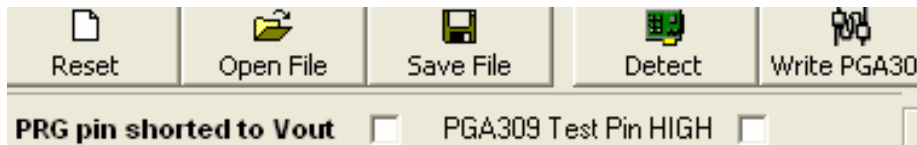

Figure 27: Miscellaneous Main Window Boxes

# Preliminary

## 8.0 PGA309 + Sensor Calibration Spreadsheet for Microsoft® Excel

The PGA309DK includes a Microsoft® Excel spreadsheet that provides a way to perform a calibration of the sensor module (PGA309 + sensor). The spreadsheet contains two parts:

Sensor Curve-Fitting Equations

Generation of Values for the PGA309 Temperature Lookup Table and Internal Register Settings.

The spreadsheet also contains VBA (Visual Basic for Applications) code that allows its integration with the Board Control Software. These macros allow the user to exchange PGA309 settings between the program and the spreadsheet and save the resulting EEPROM configuration file.

The flexibility and wide availability of Excel determined the platform for this solution. You are free to customize the sensor curve-fit model to fit your sensor better. The only prerequisites are familiarity with Microsoft Excel® capabilities and some limited knowledge of Visual Basic for Applications.

## 8.1 Sensor Curve-Fitting Equations

The built-in equations approximate the sensor with *second order polynomials* for each of the sensor three variables:

- Span vs. temperature;
- Zero offset vs. temperature ;
- Output signal vs. sensor input variable: it will be simply called pressure from now on, but can also be flow or another measured physical parameter.

The sensor curve-fit equation for this case is:

$$\text{(Equation1)} \quad K_{\text{bridge}}(p, T) = k_0 + k_1T + k_2T^2 + (k_3p + k_4p^2) \cdot (1 + k_5T + k_6T^2)$$

where:

$K_{\text{bridge}}$  = bridge output function in V/V of excitation

$p$  = sensor input variable (pressure, etc.)

$T$  = temperature in degrees C

$k_0, k_1, k_2$  = offset polynomial coefficients (initial, first and second order drift)

$k_3, k_4$  = input variable sensitivity and non-linearity

$k_5, k_6$  = span first and second order temperature drift

This is the sensor model used in the PGA309 Calibration Spreadsheet.

There are three degrees of freedom in this equation (offset and span vs. temperature and sensitivity vs. pressure), each of them is described with a quadratic equation. If we don't know much about the sensor (besides that it can be approximated with the Equation1), we need to measure three points on each degree of freedom for curve-fitting, i.e. 9 measurements: zero- and full-scale output at 3 temperatures each for offset and span and output at 3 pressure level for sensitivity. Since the min and max pressure levels for the sensitivity can be combined with zero and span measurements, this reduces the total number to 7 measurements: zero-, half-, full-scale at one of the temperatures; zero- and full-scale at each of two other temperatures. This is called the **3 temperature + 3 pressure calibration**.

Since over-temperature calibration in an oven is often a lengthy and expensive process, it is often preferred to characterize the span and offset drift non-linearities on some number of sensor samples and avoid using the 3<sup>rd</sup> temperature test in production. In this case, if we know that the sensor exhibits, for example 9% span drift non-linearity over the full temperature range and we measure only two points on this curve, we can find the equation coefficients. The same is true for offset drift and pressure non-linearity. By using this pre-characterization method we can reduce the number of required measurements to **2 temperature points with 2 pressure levels at each (2 temperature + 2 pressure calibration)**

In cases when the pressure non-linearity is not known due to bridge resistor value mismatch or other reasons, three pressure levels need to be measured at one of these temperatures (**2 temperature + 3 pressure calibration**).

The PGA309 Calibration Spreadsheet includes templates for each of the three methods described above. The exact equations for curve-fitting the sensor are not included in this document, but can be extracted from the spreadsheet cell formulas.



## ***Preliminary***

### **8.2 Calibration of Signal Path Errors**

Since we are interested in calibrating the output of a full module, "Sensor+PGA309", we can measure the output of the PGA309. Then we curve-fit the result to the same model. This will take into account all offsets, gain errors and drifts of the amplification signal path.

PGA309 and sensor must be pre-configured with desired settings: reference, excitation level, coarse gain, offset, A/D configuration, etc. The coarse settings should be based on preliminary characterization of the sensor and be such that the PGA309 produces a reasonable valid output signal range (say within 20% of the target) at both zero and full scale pressure level without saturating the internal signal path. Since the circuit offsets can be different at different gains and offset levels, the values of the all coarse settings must remain constant during the calibration processes.

The Lookup Table containing the values of the fine Zero and Gain DACs vs. Temp ADC output is created during the calibration to produce the desired output signal at all temperatures. We recommend to set both Zero and Gain DACs at mid-scale each during calibration as this allows most adjustment range for calibration.

**NOTE:** Set LinDAC=0 (linearization disabled) during calibration or a repeated re-calibration. Its value is also calculated during calibration.

# Preliminary

## 8.3 Spreadsheet Overview

The PGA309DK Calibration Spreadsheet contains the following parts:

1) The “Main” Worksheet is shown in Figure 28. It contains the current values of the PGA309 register table, the lookup table and the control buttons.

A) “Load Registers From File”

Read register values from a text file saved by PGA309DK Board Control Program.

B) “Load Registers From Bench”

Read configuration register values directly from the PGA309DK Board Control Program (must be currently running)

Using A) or B) will update the gain, offset and reference values used for calibration.

C) “Prepare Calibration Sheet”

Prepare the Worksheet “Sensor Curvefit” for calibration using one of the three templates described in Section 8.1 and start entering calibration measurements;

D) “Save Registers + Lookup Table”

After the calibration has been completed you have to return to this Worksheet and save the resulting configuration register values and the Lookup Table to a text file. The file can be later read by the PGA309 Board Control Program and written into EEPROM on the PGA309 Sensor Interface Board.

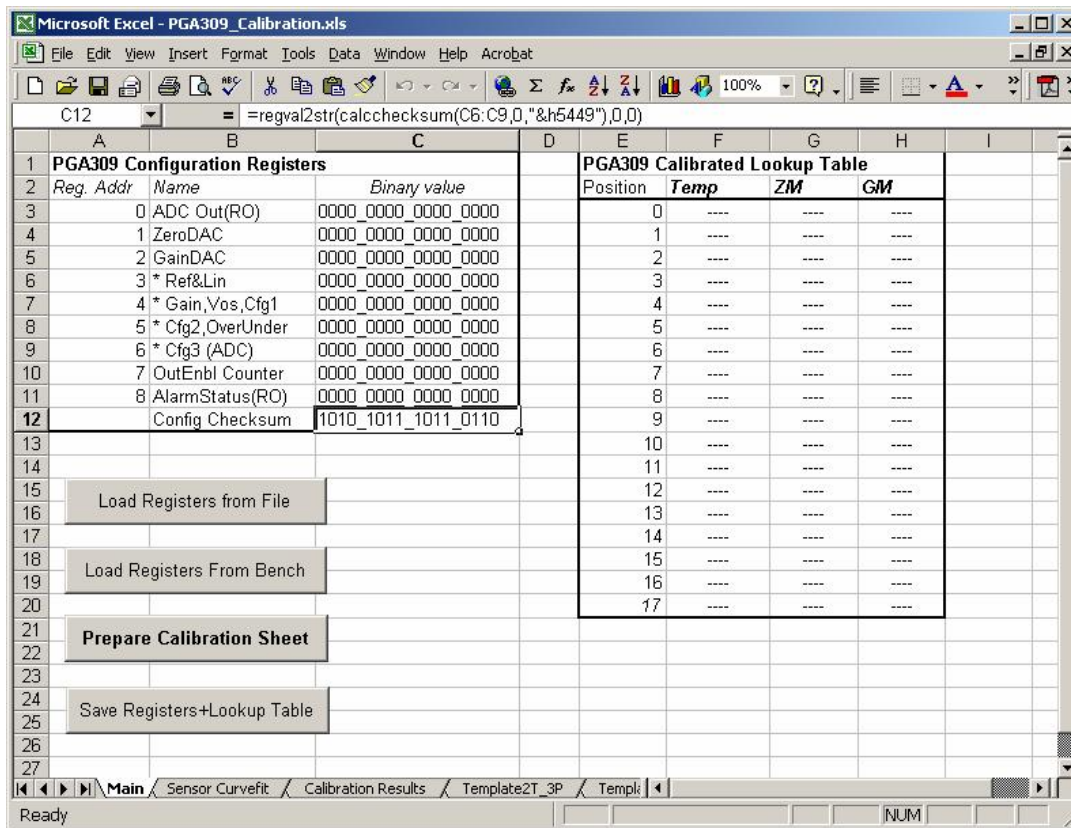

Figure 28: “Main” Worksheet

# Preliminary

2) The "Sensor Curvefit" Worksheet (Figure 29) is the place where all results of the calibration measurements are calculated. The fields colored light blue contain pre-selected values, such as PGA309 Gain and Offset settings, the temperatures where the measurements are made and sensor pre-characterized parameters (such as span drift non-linearity). The dark-blue fields are the ones where the measured values are entered at each stage of the calibration. The framed area is filled out when "Prepare Calibration Sheet" is clicked on the previous page. It contains the cells with calculations specific to the chosen calibration algorithm. The two control buttons paste in the current worksheet cell either the last Vout reading or the last Temp ADC value from the Board Control Program. This saves the manual typing of the numbers. However, all the data can be also entered manually if the measurements are made with other equipment than the PGA309DK PC Interface Board.

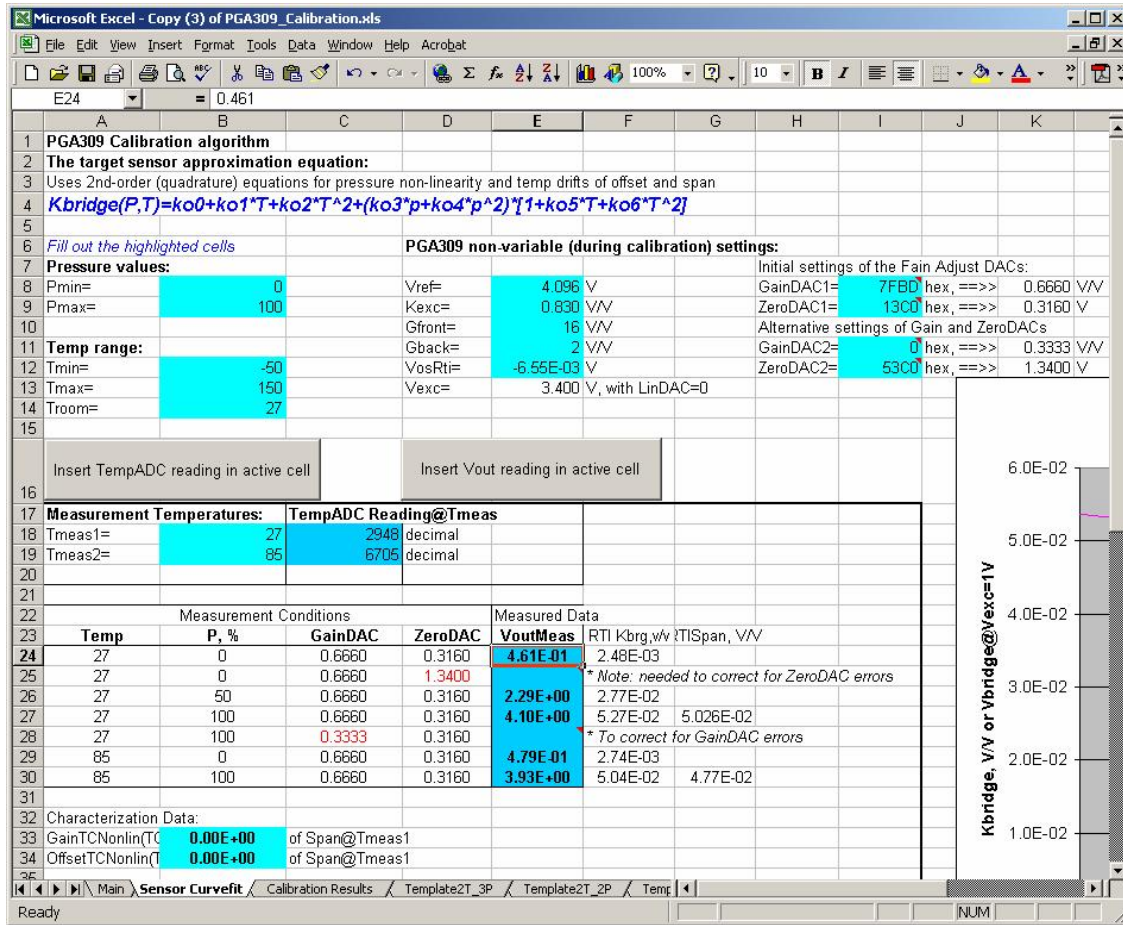

Figure 29: Sensor Curvefit Worksheet

# Preliminary

Upon completion of the measurements the fitted sensor function is displayed on two plots located on this worksheet (see Figure 30): offset and span vs. temperature and Vbridge vs. input pressure

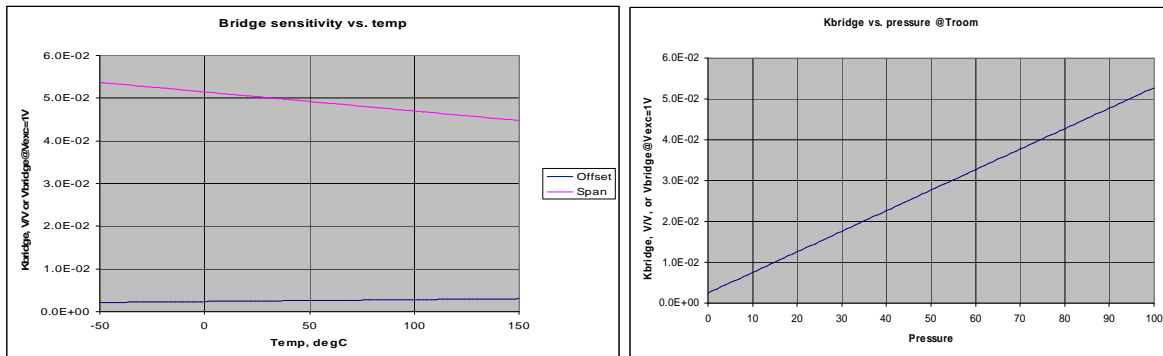

Figure 30: Approximated Sensor Curves

3) The third worksheet is called "Calibration Results" (see Figure 31). It contains the calculated lookup table based on the curve-fitting coefficients from the calibration measurements. The blue fields are for the user data with the desired output voltage scale, compensation temperature range and the number of the lookup table points needed. The framed cells contain the messages about the validity of the calculated values: whether the DAC and Temp ADC values are in linear range achievable by PGA309 at all temperatures and the Table is arranged properly. The plot on the bottom shows the expected PGA309 output vs. temperature at zero and full-scale output signal.

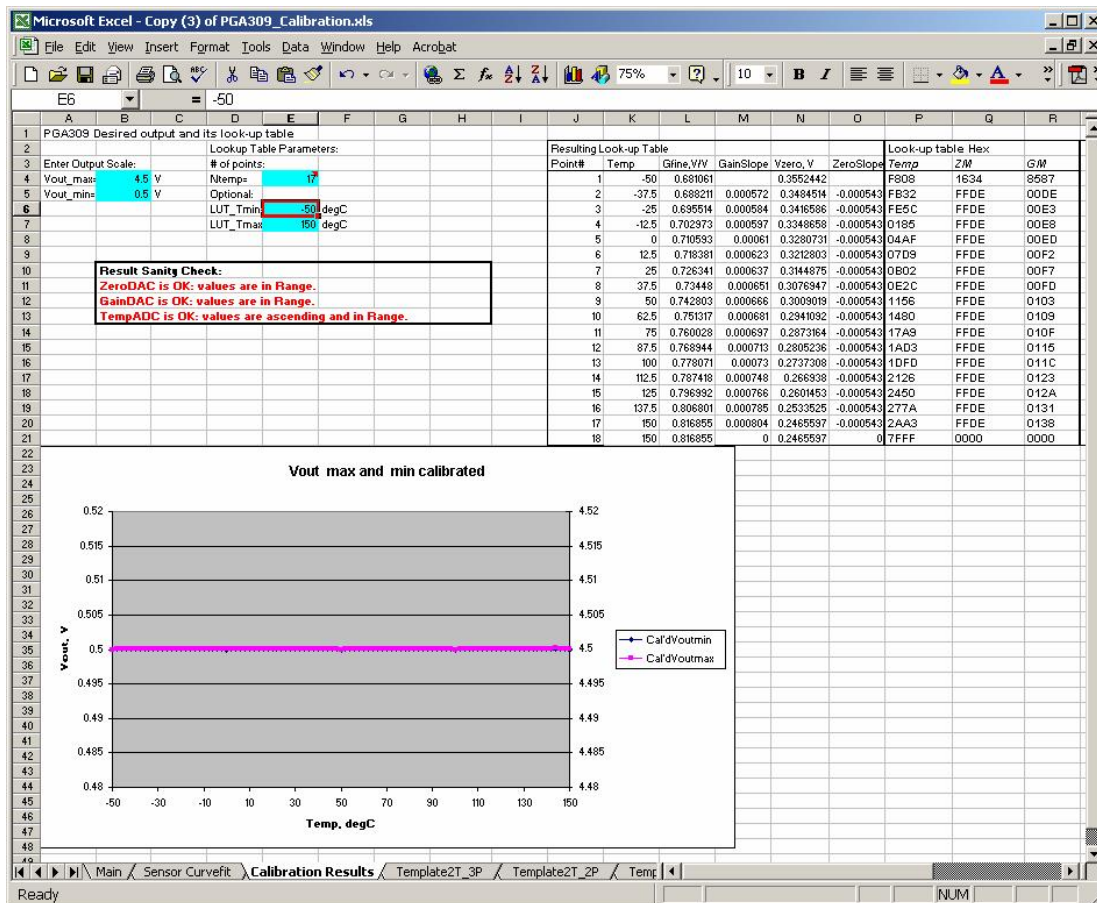

Figure 31: Calibration Results

# Preliminary

4) The remainder of the worksheets contain the templates of the curve-fitting algorithms and back-ground calculation data.

## 8.4 Step-by-Step Calibration Using PGA309 Designer's Kit.

1) The PGA309DK Sensor Interface Board with a sensor or a custom module are initially configured as described in Section 8.2. It is measured at the first (usually the room) temperature,  $T_{meas1}$ , and at either 2 or 3 pressure levels (see Section 8.1). The output should be within the adjustment ranges of the Zero and Gain DACs. It is important to enable the EXTEN and INTEN bits and/or read back the Alarm Status (Register 8) to see if any of the external or internal comparators raised a flag indicating either sensor fault or an internal signal path saturation. In case of a fault or an unsatisfactory output signal range the coarse settings must be adjusted and the measurement repeated. After a valid output range has been achieved, the following settings must remain fixed:

- § Reference and Excitation Level
- § Coarse RTI Offset,
- § Coarse Front-End and Output Amplifier Gains,
- § Temp ADC Configuration, etc.

2) The current configuration must be entered into the PGA309 Calibration spreadsheet. To do this, perform the following actions:

A) Open the PGA309 Calibration Spreadsheet (click "Enable Marcos" if asked). Upon opening you will be asked if you would like to open the "PGA309DK Board Control Program". Answer "Yes". If you already have the software running, a new window will not be open, but a data link will be established.

B) Make sure the current PGA309 register values are displayed in the Board Control Program (click "Read PGA309" button – see Figure 32).

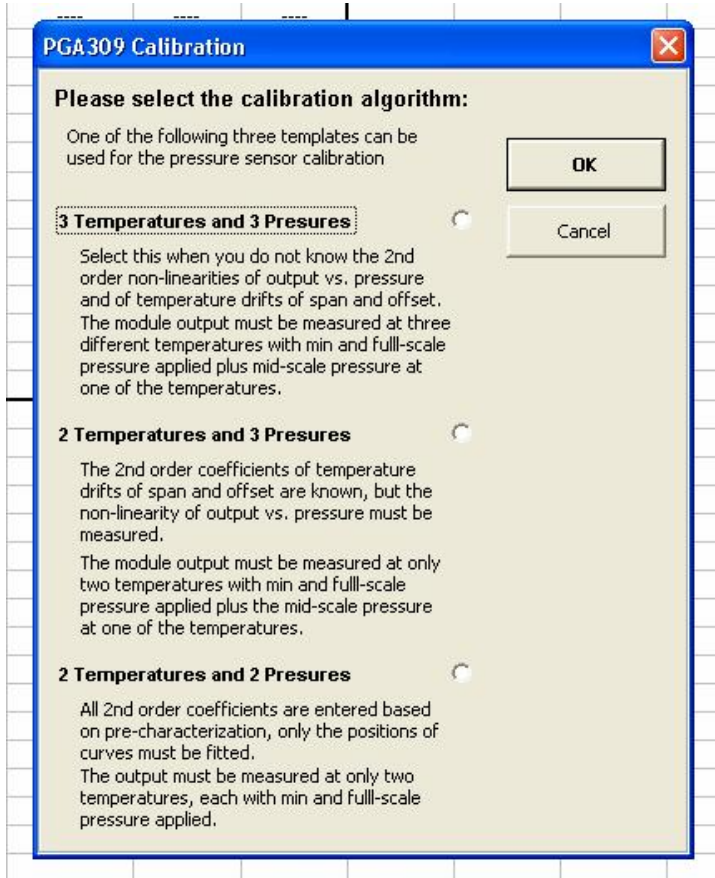

**Figure 32: Board Control Software Main Window "Read PGA" Button**

C) Return to the "Main" Worksheet and click "Load Registers from Bench". The register values in the cells B3:B12 will be updated. The values of the gain, offset and other parameters are set on the next worksheet accordingly to the PGA309 register configuration.

D) Click "Prepare Calibration Sheet". The dialog box in Figure 33 will appear. Select the appropriate algorithm. The script will copy the right template to the "Sensor Curvefit" Worksheet and open the next page.

# Preliminary



**Figure 33: Select Calibration Algorithm Dialog**

E) Verify and correct the parameter values in the light-blue cells on the “Sensor Curvefit” Worksheet. (Figure 34).

Fill out the highlighted cells

<b>Pressure values:</b>			
Pmin=	0	Vref=	4.096 V
Pmax=	100	Kexc=	0.830 V/V
		Gfront=	16 V/V
<b>Temp range:</b>		Gback=	2 V/V
Tmin=	-50	VosRti=	-6.55E-03 V
Tmax=	150	Vexc=	3.400 V, with LinDAC=0
Troom=	27		

**PGA309 non-variable (during calibration) settings:**

Initial settings of the Fain Adjust DACs:

GainDAC1=	7FBD hex, ==>>	0.6660 V/V
ZeroDAC1=	13C0 hex, ==>>	0.3160 V
Alternative settings of Gain and ZeroDACs		
GainDAC2=	0 hex, ==>>	0.3333 V/V
ZeroDAC2=	0 hex, ==>>	0.0000 V

Buttons: Insert TempADC reading in active cell, Insert Vout reading in active cell

6.0E-02

**Figure 34: Top Part of the “Curvefit” Worksheet**

3) Update the Temp ADC reading in the Board Control Program by clicking “Convert” in its Main Window (see Figure 35). Return to the “Sensor Curvefit” Worksheet, highlight the cell C18 (ADC read @ Tmeas1) and click the button “Insert Temp ADC Reading” (Figure 36).



**Figure 35: Board Control Software Main Window “Convert” Button**

# Preliminary

Insert TempADC reading in active cell

Insert Vout reading in active cell

Measurement Temperatures:		TempADC Reading@Tmeas	
Tmeas1=	27	2948	decimal
Tmeas2=	85	6705	decimal

step 3

step 4

step 5

Measurement Conditions				Measured Data		
Temp	P, %	GainDAC	ZeroDAC	VoutMeas	RTI Kbrg,v/v	RTISpan, V/V
27	0	0.6660	0.3160	4.61E-01	2.48E-03	
27	0	0.6660	0.0000	2.29E+00	2.77E-02	
27	50	0.6660	0.3160	4.10E+00	5.27E-02	5.026E-02
27	100	0.6660	0.3160	4.10E+00	5.27E-02	5.026E-02

\* Note: needed to correct for ZeroDAC errors

**Figure 36: Entering the Values for Tmeas1 and Vout @ Tmeas1**

- 4) Apply the Pressure Pmin to the sensor. Make sure the PGA309 output is enabled and click "Update Vout" (see Figure 37) in the Board Control Program or measure Vout using a voltmeter. Return to the spreadsheet, highlight the cell E24 (VoutMeas @ Pmin, Tmeas1) and click the button Insert "Vout Reading" or enter the measured voltage by hand (Figure 36).



**Figure 37: Board Control Software Main Window "Update Vout" Button**

- 5) Repeat Step 4 for measuring the max-scale and (if needed) mid-scale Vout values in the cells E26, [E27].
- 6) Place the Sensor + PGA309 at the temperature Tmeas2 and repeat the Steps 3, 4, 5 entering the values to the corresponding cells below the ones shown in Figure 36. At each stage make sure the signal path of the PGA309 is not overloaded by reading the state of the Alarm Register.
- 7) If using the "2 Temperature + 3 Pressures" or "2 Temperature + 2 Pressures" algorithms, enter the second order parameter non-linearities of the sensor in the highlighted cells B33:B36.
- 8) Verify that the resulting fitted sensor approximation (Figure 30) are in agreement with the characterization data.
- 9) Go to the next Worksheet, "Calibration Results", and enter the desired output voltage scale in the cells B4, B5, the number of the Lookup Table points in the cell E4 and the temperature range where the calibrated output signal is expected in cells E6, E7 (see Figure 38). Note that this can be a narrower range than the Tmin-Tmax range used for the sensor curve-fitting. Using a smaller temp range will reduce the spacing between the points on the piece-wise linear (PWL) gain and offset curves generated by PGA309. This in turn, will reduce the residual 3<sup>rd</sup> order errors of the output. The resulting lookup table and the simulated plot at the bottom of the page get instantly updated. The plot axes might have to be adjusted to display the curves properly. Pay attention to the "Result Sanity Check" messages in the cells B11:B13. If the required DAC or ADC values are outside of the linear ranges of the PGA309 the message will inform you about it. This means that the coarse parameters of the PGA309 must be adjusted and the calibration has to be repeated.

# Preliminary

## PGA309 Desired output and its look-up table

Enter Output Scale:  
 Vout\_max= 4.5 V  
 Vout\_min= 0.5 V

Lookup Table Parameters:  
 # of points: 17  
 Ntemp= 17  
 Optional:  
 LUT\_Tmin= -50 degC  
 LUT\_Tmax= 150 degC

**Result Sanity Check:**  
 ZeroDAC is OK: values are in Range.  
 GainDAC is OK: values are in Range.  
 TempADC is OK: values are ascending and in Range.

Resulting Look-up Table						Look-up table Hex	
Point#	Temp	Gfine_V/V	GainSlope	Vzero_V	ZeroSlope	Temp	ZM
1	-50	0.703735		0.286542		F808	11E9
2	-37.5	0.706215	0.000198	0.29596	0.000753	FB32	002F
3	-25	0.709357	0.000251	0.303348	0.000591	FE5C	0026
4	-12.5	0.713177	0.000306	0.308706	0.000429	0185	001B
5	0	0.717697	0.000362	0.312034	0.000266	04AF	0011
6	12.5	0.722944	0.00042	0.313332	0.000104	07D9	0006
7	25	0.728947	0.00048	0.3126	-5.85E-05	0B02	FFFD
8	37.5	0.735743	0.000544	0.309839	-0.000221	0E2C	FFF2
9	50	0.743374	0.00061	0.305048	-0.000383	1156	FFE8
10	62.5	0.751888	0.000681	0.298227	-0.000546	1480	FFDE
11	75	0.76134	0.000756	0.289376	-0.000708	17A9	FFD3
12	87.5	0.771795	0.000836	0.278495	-0.00087	1AD3	FFC9
13	100	0.783326	0.000922	0.265584	-0.001033	1DFD	FFB4
14	112.5	0.796016	0.001015	0.250644	-0.001195	2126	FFB4
15	125	0.809964	0.001116	0.233674	-0.001358	2450	FFA0
16	137.5	0.82528	0.001225	0.214673	-0.00152	277A	FFA0
17	150	0.842093	0.001345	0.193643	-0.001682	2AA3	FF95
18	150	0.842093	0	0.193643	0	7FFF	0000

Vout max and min calibrated

**Figure 38: Calibration Results Worksheet**

- 10) Return to the "Main" Worksheet and click on the "Save Register+Lookup Table" button to save the calibration results in a file. Now load this file to the PGA309 EEPROM using Board Control Program by using the "Open File" button, and then the "Write EEPROM" button.
- 11) Verify that the output of the PGA309 is satisfactory.
- 12) Optional: To account for the offset and gain errors of the PGA309 ZeroDAC and GainDAC, two additional measurements might need to be performed after Step 4 and Step 5 correspondingly. This should improve the calibrated output precision.
  - A) After Step 4, while Pmin is applied to the sensor, adjust the value of the ZeroDAC and measure the output of the PGA309. Select a ZeroDAC value that does not saturate the signal path while giving you a largest Vout change. Enter the ZeroDAC hex value in the cell I12 and the Vout reading in the cell E25 or E26 (depending on the template used). This calculates a ZeroDAC correction factor in the cell I37. Return the Zero DAC to its original value.
  - B) After step 5, while Pmax is applied to the sensor, adjust the value of the GainDAC and measure the output of the PGA309. Select a GainDAC value that does not saturate the output amplifier while giving you a largest Vout change. Enter the GainDAC hex value in the cell I11 and the Vout reading in the cell E28 or E29 (depending on the template used). This calculates a GainDAC correction factor in the cell I36. Return the Gain DAC to its original value. Please note, when using these correction factors, the resulting plot on the Calibration Results worksheet will appear off-target.

Initial Settings Tip: Use the coarse offset adjustment on the PGA309 to maximize the adjustment range for the Zero DAC (refer to the Offset Scaling Section of the PGA309 User's Guide).

### 8.4 Customization of the PGA309DK Calibration Spreadsheet

All of the cells as well as the VBA code in the spreadsheet are open and can be modified and adjusted for individual design and sensor properties. The name of the custom sensor curve-fitting function is *sensbridge()*. This function can be modified to fit sensors modeled by more complex equations than shown in Equation1. In this case the following parts of the spreadsheet must also be updated:

- curve-fitting coefficient equations in the framed area A17:I52, worksheet Sensor Curvefit;
- references to the *sensbridge()* in the cell equations in the worksheet Sensor Data vs. Temp, columns D, F, K, L;
- references to the *sensbridge()* in the cell equations in the worksheet Sensor Data vs. Pressure, column B

*Note:* The equations generating the Lookup Table in the worksheet Calibration Results can stay.



## Preliminary

### 9.0 General Operating Tips

- 1) During initial evaluation of the PGA309 + Sensor it is recommended to leave the PRG pin separate from the Vout pin of the PGA309. Disable the Two-Wire interface on the PGA309 PC Interface Board and use the One-Wire Interface. Disabling the Two-Wire interface keeps communications to the PGA309 PC Interface port expander, PCF8574A, and A/D Converter, ADS1100, from being delayed by the PGA309 talking to its external EEPROM, if PGA309 is in Stand-Alone Mode. Communication on the One-Wire interface will always be recognized and will stop PGA309 to external EEPROM communication.
- 2) For final production testing on 3 terminal sensor modules (Vcc, GND, Vout), where PRG is tied to Vout, use the One-Wire hardware pull-up on the PGA309 PC Interface Board for reliable logic level transitions.
- 3) Upon initial receipt of the PGA309DK, first perform the Initial Setup and Checkout as described in Section 6.0. If there is ever a doubt as to proper functioning of the PGA309DK return to this configuration and use Section 6.0 to verify proper operation. Next configure the PGA309 Sensor Interface Board with your Sensor for evaluation. Connect the PGA309 Sensor Interface Board to the PGA309 PC Interface Board using wire to connect the required signals together. If all tests pass then move the PGA309 Sensor Interface Board into the temperature chamber for PGA309 + Sensor calibration.
- 4) When Reading and Writing to the PGA309 through the Board Interface Software push the desired button in the Main Window *ONE TIME* and wait until the "Board Communication Status" returns to "Board Communication Idle" before pushing any button. Repeated pushing of buttons when the Board Software is in the middle of communication with the PGA309 will cause unreliable data transfer and nuisance errors.
- 5) The "most quiet" analog readings, with a voltmeter or oscilloscope, on Vout of the PGA309 are accomplished when there is no digital activity from the test PC to the PGA309 PC Interface Board and the PGA309 Two-Wire Bus is isolated from the PGA309 PC Interface Board. The RS-232 interface chip, U9 (MAX3238), on the PGA309 PC Interface Board has a shutdown feature which disables the on-board positive and negative charge pumps. These capacitive charge pumps are noisy and every attempt has been made on the PC Interface board to filter them away from the Vs for the PGA309. However, some amount of noise does still exist and as such does not give a true indication of the PGA309 noise performance on its output (Vout). After 30 seconds of inactivity on U9 the internal charge pumps are shutdown. Easiest check that U9 is in shutdown is to probe TP:V- for a voltage reading of <0.1Vdc. To ensure U9 goes into shutdown cease all communications to the PC Interface Board through the RS-232 Interface (Ppc) and ensure that the Two-Wire interface is disabled from the Sensor Interface Board through either software or hardware program selection of disable on U10 and U11. Once U9 is shutdown a "quiet" reading on Vout of the PGA309 can be taken.
- 6) The on-board ADC, ADS1100, on the PGA309 PC Interface Board requires two calibration steps for optimal accuracy. The "gain" of the ADS1100 is set by its reference voltage which is the supply, Vs. Measure Vs on the PGA309 PC Interface Board test point TP:Vs. Ensure that the nVsens bit in the PCF8574A port expander is set to '0' (See Figure 19: ADS1100 and PCF8574A Status and Control Pop-up Window) to turn Vs on. Enter the measured value of Vs into the "Supply Vcc (V)" box under the "Interface board and ADS1100" in the Main Window. After this is complete go to the "ADS1100 and PCF8574A Status" pop-up window (See Figure 19). Click on "Calibrate the ADS1100". This will measure the offset on the ADS1100 and the Board Control Software will adjust all future readings to account for the offset.

# Preliminary

## 10.0 PGA309DK PC Cable Drawing

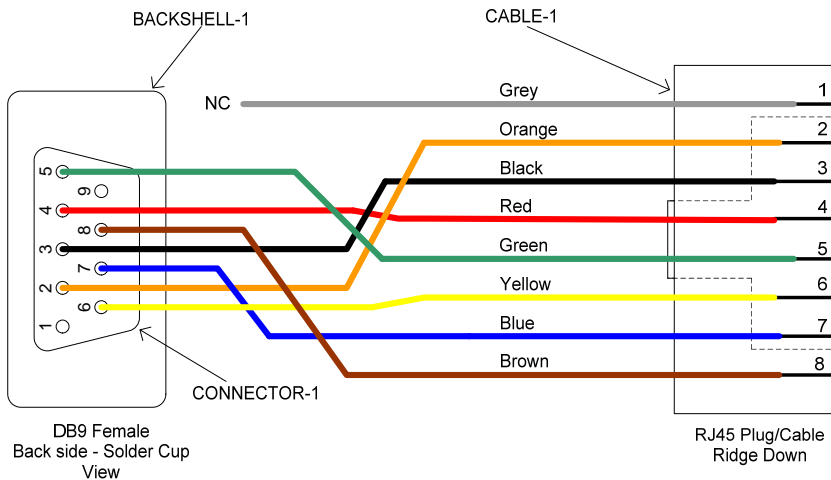

- 1 - No Connection
- 2 - RD
- 3 - TD
- 4 - DTR
- 5 - GND
- 6 - DSR
- 7 - RTS
- 8 - CTS
- 9 - No Connection

### PGA309 EVM PC Cable Drawing

THG January 16, 2004

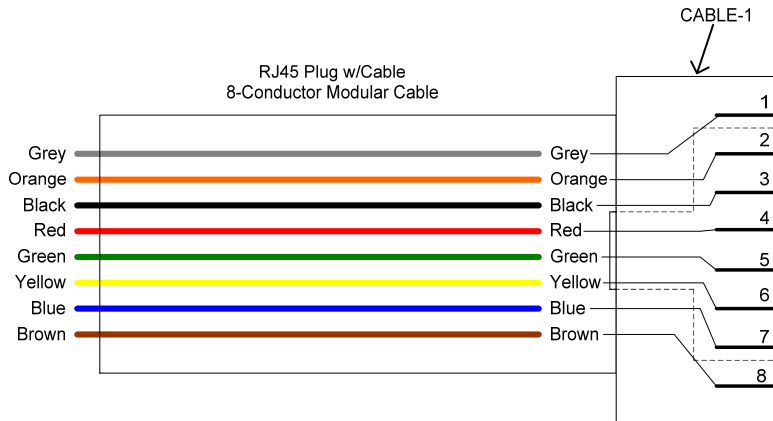



# Preliminary

## PGA309DK IMPORTANT NOTICE

Texas Instruments (TI) provides the enclosed product(s) under the following conditions:

This evaluation kit being sold by TI is intended for use for **ENGINEERING DEVELOPMENT OR EVALUATION PURPOSES ONLY** and is not considered by TI to be fit for commercial use. As such, the goods being provided may not be complete in terms of required design-, marketing-, and/or manufacturing-related protective considerations, including product safety measures typically found in the end product incorporating the goods. As a prototype, this product does not fall within the scope of the European Union directive on electromagnetic compatibility and therefore may not meet the technical requirements of the directive.

Should this evaluation kit not meet the specifications indicated in the PGA309DK User's Manual, the kit may be returned within 30 days from the date of delivery for a full refund. THE FOREGOING WARRANTY IS THE EXCLUSIVE WARRANTY MADE BY SELLER TO BUYER AND IS IN LIEU OF ALL OTHER WARRANTIES, EXPRESSED, IMPLIED, OR STATUTORY, INCLUDING ANY WARRANTY OF MERCHANTABILITY OR FITNESS FOR ANY PARTICULAR PURPOSE.

The user assumes all responsibility and liability for proper and safe handling of the goods. Further, the user indemnifies TI from all claims arising from the handling or use of the goods. Please be aware that the products received may not be regulatory compliant or agency certified (FCC, UL, CE, etc.). Due to the open construction of the product, it is the user's responsibility to take any and all appropriate precautions with regard to electrostatic discharge.

EXCEPT TO THE EXTENT OF THE INDEMNITY SET FORTH ABOVE, NEITHER PARTY SHALL BE LIABLE TO THE OTHER FOR ANY INDIRECT, SPECIAL, INCIDENTAL, OR CONSEQUENTIAL DAMAGES.

TI currently deals with a variety of customers for products, and therefore our arrangement with the user **is not exclusive**.

TI assumes **no liability for applications assistance, customer product design, software performance, or infringement of patents or services described herein**.

Please read the PGA309DK User's Manual and PGA309 Data Sheet and, specifically, the Warnings and Restrictions notices in the Manual and Data Sheet prior to handling the product. This notice contains important safety information about temperatures and voltages. For further safety concerns, please contact the TI application engineer.

Persons handling the product must have electronics training and observe good laboratory practice standards.

No license is granted under any patent right or other intellectual property right of TI covering or relating to any machine, process, or combination in which such TI products or services might be or are used.

Mailing Address:  
Texas Instruments  
Post Office Box 655303  
Dallas, Texas 75265

Copyright © 2004, Texas Instruments Incorporated

# ***Preliminary***

## **IMPORTANT NOTICE**

Texas Instruments Incorporated and its subsidiaries (TI) reserve the right to make corrections, modifications, enhancements, improvements, and other changes to its products and services at any time and to discontinue any product or service without notice. Customers should obtain the latest relevant information before placing orders and should verify that such information is current and complete. All products are sold subject to TI's terms and conditions of sale supplied at the time of order acknowledgment.

TI warrants performance of its hardware products to the specifications applicable at the time of sale in accordance with TI's standard warranty. Testing and other quality control techniques are used to the extent TI deems necessary to support this warranty. Except where mandated by government requirements, testing of all parameters of each product is not necessarily performed.

TI assumes no liability for applications assistance or customer product design. Customers are responsible for their products and applications using TI components. To minimize the risks associated with customer products and applications, customers should provide adequate design and operating safeguards.

TI does not warrant or represent that any license, either express or implied, is granted under any TI patent right, copyright, mask work right, or other TI intellectual property right relating to any combination, machine, or process in which TI products or services are used. Information published by TI regarding third-party products or services does not constitute a license from TI to use such products or services or a warranty or endorsement thereof. Use of such information may require a license from a third party under the patents or other intellectual property of the third party, or a license from TI under the patents or other intellectual property of TI.

Reproduction of information in TI data books or data sheets is permissible only if reproduction is without alteration and is accompanied by all associated warranties, conditions, limitations, and notices. Reproduction of this information with alteration is an unfair and deceptive business practice. TI is not responsible or liable for such altered documentation.

Resale of TI products or services with statements different from or beyond the parameters stated by TI for that product or service voids all express and any implied warranties for the associated TI product or service and is an unfair and deceptive business practice. TI is not responsible or liable for any such statements.

Mailing Address:  
Texas Instruments  
Post Office Box 655303  
Dallas, Texas 75265

Copyright © 2004, Texas Instruments Incorporated