

Holmes®

Warm Mist Humidifier

HM5600

Owner's Guide



FILTER# WMF50

FILTER TYPE: WATER PURIFICATION

PLEASE READ AND SAVE THESE IMPORTANT INSTRUCTIONS

PLEASE READ AND SAVE THESE IMPORTANT SAFETY INSTRUCTIONS

When using electrical appliances, basic safety precautions should always be followed to reduce the risk of fire, electric shock, and injury to persons, including the following:

1. Read all instructions before using the appliance.
2. To avoid fire or shock hazard, plug the appliance directly into a 120 V AC electrical outlet.
3. Keep the cord out of heavy traffic areas. To avoid fire hazard, NEVER put the cord under rugs, near heat registers, radiator, stoves, or heaters.
4. DO NOT place humidifier near heat sources such as stoves, radiators, and heaters. Do locate your humidifier on an inside wall near an electrical outlet. The humidifier should be at least 4" away from the wall for best results.
5. NEVER place humidifier in an area where it is accessible to children. NEVER use humidifier in a closed room, particularly where a child may be sleeping, resting, or playing (a closed room may result in excessive humidity).
6. WARNING: Do not attempt to refill humidifier without first unplugging the unit from its electrical outlet. Failure to heed this warning may cause personal injury. Be sure to pull by the plug and not the cord.
7. NEVER drop or insert any object into any openings. DO NOT place hands, face, or body directly over or near Moisture Outlet while unit is in operation. DO NOT cover Moisture Outlet or place anything over it while the unit is operating.
8. DO NOT operate any appliance with a damaged cord or plug, after the appliance malfunctions, or if it has been dropped or damaged in any manner. Return appliance to manufacturer for examination, electrical or mechanical adjustment, or repair.
9. Use appliance only for intended household use as described in this manual. Any other use not recommended by the manufacturer may cause fire, electric shock, or injury to persons. The use of attachments not recommended or sold by Holmes may cause hazards.
10. DO NOT use outdoors.
11. Always place humidifier on a firm, flat, level surface. A waterproof mat or pad is recommended for under the humidifier. NEVER place it on a rug or carpet, or on a finished floor that may be damaged by exposure to water or moisture.
12. DO NOT allow the Moisture Outlet to directly face the wall. Moisture could cause damage, particularly to wallpaper.
13. Humidifier should be unplugged when not in use.
14. NEVER tilt, move, or attempt to empty unit while it is operating. Shut off and unplug before removing the water tank and moving the unit. DO NOT attempt to remove the water tank within 15 minutes after the humidifier is turned off and unplugged. Serious injury may result.
15. This humidifier requires daily and weekly maintenance to operate appropriately. Refer to daily and weekly cleaning procedures.
16. NEVER use detergents, gasoline, glass cleaner, furniture polish, paint thinner, or other household solvents to clean any part of the humidifier.
17. Excessive humidity in a room can cause water condensation on windows and some furniture. If this happens, turn the humidifier OFF.
18. Do not use humidifier in an area where humidity level is in excess of 50%. Use the included hygrometer or purchase one at your local hardware store or through Holmes, to measure the humidity.
19. DO NOT attempt to repair or adjust any electrical or mechanical functions on this unit. Doing so will void your warranty. The inside of the unit contains no user serviceable parts. All servicing should be performed by qualified personnel only.
20. Never place housing under water flow, or immerse in liquids.
21. DO NOT plug in with wet hands: electric shock could result.
22. DO NOT pour water in any openings other than the water tank.
23. Allow unit to cool before refilling water tank or maintenance as the heater bulb is hot.
24. To prevent damage to surfaces, do not place humidifier under overhanging surfaces.

PLEASE READ AND SAVE THESE IMPORTANT SAFETY INSTRUCTIONS

Consumer Safety Information

Note: This is an electrical appliance and requires attention when in use.

Note: If moisture forms on the walls or windows of the room, turn off the humidifier. The room already has plenty of humidity and additional moisture may cause damage.

Note: DO NOT block air inlet or outlet.

Cord and Plug Installation Safety Instructions

The length of cord used on this appliance was selected to reduce the hazards of becoming tangled in, or tripping over a longer cord. If a longer cord is necessary an approved extension cord may be used. The electrical rating of the extension cord must be equal to or greater than the rating of the humidifier. Care must be taken to arrange the extension cord so that it will not drape over the countertop or tabletop where it can be pulled on by children or accidentally tripped over.



THIS PRODUCT IS EQUIPPED WITH A POLARIZED AC (Alternating Current) PLUG (a plug having one blade wider than the other). This plug will fit into the power outlet only one way. If the plug does not fit fully into the outlet, reverse the plug. If it still does not fit, contact qualified personnel to install the proper outlet. DO NOT DEFEAT THE SAFETY PURPOSE OF THIS POLARIZED PLUG IN ANY WAY.

FEATURES - OPERATION

HOW WARM MIST WORKS

Your Holmes Warm Mist humidifier is designed to allow the proper amount of water to flow out of the tank. Air is drawn in through the grill openings located in the back of the unit and mixed with steam in the misting chamber. The warm mist is then dispersed out of the top of the misting chamber through the outlet grill and into the room. **NOTE:** A humidity level below 20% can be unhealthy and uncomfortable. The recommended humidity level is between 40%-50%.

PRE-OPERATING INSTRUCTIONS

1. Be sure the humidifier is disconnected from the electrical outlet and the power knob is in the OFF position.
2. Select a location for your humidifier, on a flat surface, about 4" away from the wall. Do not place your humidifier on furniture. A flat, smooth, surface that will not be damaged by moisture is best.

FILLING THE TANK

NOTE: This humidifier holds about 1.8 gallons of water in the tank and humidifier base. The humidifier will produce up to 3 gallons of moisture over a 24-hour period, depending on the room humidity and temperature.

1. Be sure the humidifier is disconnected from the electrical outlet and the power knob is in the OFF position.
2. Remove the water tank (see Figure 1), by holding the tank handle and lifting straight upward.

NOTE: Ensure safety lock is rotated completely clockwise.

3. Twist off the tank cap located on the bottom of the tank by turning counter clockwise. Fill the water tank with cool, fresh water. **Do not fill with warm water as this may cause leaking.**
4. After filling the tank, replace the tank cap by firmly turning clockwise and then replace the water tank on the base. The tank will immediately begin to empty into the base.
5. Plug the power cord into a 120V AC electrical outlet

OPERATING INSTRUCTIONS

IMPORTANT:

When using the Water Purification Filter in the humidifier for the first time, wait 15 minutes for the water to pass through the filter before switching on the humidifier.

1. Turn the Power Knob to the HIGH position. The power light will be ON and the Reset Light will be OFF. It is normal for the humidifier to take about 2-3 minutes to warm up and begin to mist.
2. After the unit begins misting, set the humidifier to the desired power setting (HIGH or LOW).
3. The Medicine Cup is located on the top of the mist chamber. To use, pour designated humidifier medication into the cup. **DO NOT** add medication to the water tank. **DO NOT** add medication to the medicine cup when the unit is already operating.

RESET PROCEDURE

NOTE: When the water tank is empty and the water in the Heating Chamber is almost empty, the Automatic Shut Off will activate. The RESET Light will illuminate and the unit will not operate again until you refill the water tank and reset the humidifier.

1. Turn the power knob to OFF.
2. Unplug the unit.
3. Remove and refill the water tank, being sure to follow the Daily Maintenance Instructions. Replace the tank onto the base.
4. Wait 5 minutes for the Automatic Shut-Off to reset.
5. After the 5 minutes, plug in the unit and turn the Power Knob, to HIGH. The RESET light should now be off (if not repeat steps 1 through 5). In about 2-3 minutes, the humidifier will begin to produce moisture.

If the RESET light is still on at this point, and the unit does not begin to produce moisture within a few minutes, then repeat Steps 1-5.

IMPORTANT: If you do not plan to use the humidifier for two or more days, make sure any residual water is drained from the water tank and base to prevent algae or bacteria growth.

USING THE HUMIDISTAT

The Humidistat feature allows you to set and maintain the humidity level you wish for your room to maintain. The Humidistat setting is designed to operate between 25% and 65% relative humidity range. The recommended setting is 40-50%. Turn the knob clockwise as far as it will turn to achieve the highest humidistat setting. In this setting, the humidifier will run constantly. To lower your desired humidity level, simply turn the knob counterclockwise to choose your setting. When the humidity in the room is less than the level you have set, the humidifier will continue to produce moisture. Once the set humidity level has been achieved, the fan will turn off. When the room humidity drops below your set level, the unit will automatically begin producing moisture again. Depending on the size of your room and your personal comfort, you will set your humidistat at different levels. If condensation forms on your windows or walls, or your measured room humidity reads above 50% by use of a hygrometer, turn off your humidifier, or lower your Humidistat level.

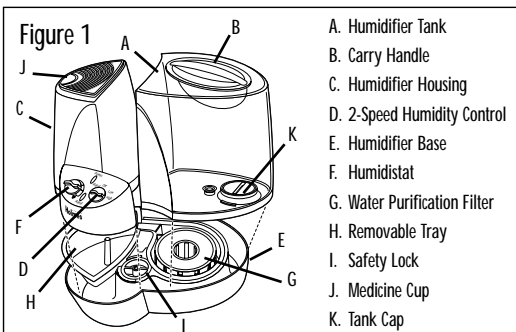

CLEANING/MAINTENANCE

REPLACING THE FILTER

WARM MIST CLEANING AND MAINTENANCE INSTRUCTIONS

The following maintenance procedures must be routinely followed in order to ensure proper, efficient operation of your humidifier. The unit **WILL FAIL** if it is not cleaned properly.

When the unit is in use, daily and weekly maintenance is recommended. Regular weekly cleaning prevents scale buildup on the heating element and tray. It also prevents micro-organisms from growing on the tray and tank. This ensures that maximum efficiency will be achieved.

We cannot over-emphasize how essential proper cleaning is to the maintenance and continued use of your unit and to the avoidance of algae or bacteria build-up.

Daily Maintenance

Allow to cool before maintenance.

1. Before cleaning, set the control to OFF position and unplug the unit from the electrical outlet.
2. Remove the water tank then unlock the misting chamber by rotating the safety lock towards the front of the unit. Lift mist chamber from the unit's base. Now lift the tray from the base.
3. Empty water and minerals from the tray and place in the top rack of the dishwasher. This will remove any sediment and dirt that has accumulated in the tray.

NOTE: It is imperative that the tray is cleaned properly. The tray is dishwasher safe (top rack ONLY) for easy cleaning.

4. Wipe the heating element clean with a soft cloth after it has had a chance to cool.
5. Replace misting chamber and engage safety lock.

The Electronic Thermal Control Heating element is lined with a Teflon® coating that is designed to provide the easiest cleaning and prolong the operating efficiency of the humidifier. **DO NOT** use any metal or hard objects to clean the Heating Element. Never use detergents, gasoline, kerosene, glass cleaner, furniture polish, paint thinner or other household solvents to clean any part of the humidifier.

Weekly Maintenance

Remove scale: Allow to cool before maintenance.

1. Repeat steps 1-5 in the Daily Maintenance section.
2. Clean the tray by partially filling the tray with one 8-oz cup of undiluted white vinegar. Let solution stand 20 minutes, cleaning all interior surfaces with a soft brush. Dampen a cloth with undiluted white vinegar and wipe out entire tray to remove scale.
3. Rinse with clean warm water to remove scale and the white vinegar solution before beginning to disinfect the tank.
4. Wipe the heating element clean with a soft cloth after it has had a chance to cool.

Disinfect tank:

1. Fill tank with 1/2 teaspoon of chlorine bleach and 1/2 gallon of water.
2. Let the solution stand for 20 minutes, swishing every few minutes. Wet all surfaces.
3. Empty the tank after 20 minutes, and rinse well with water until the bleach smell is gone. Dry with a clean cloth or paper towel.
4. Refill the water tank with cool water; replace the housing and water tank. Repeat ALL Operating Instructions.

REPLACING THE WARM MIST WATER PURIFICATION FILTER

The water purification filter is used to trap minerals in your water and provide a clean moisture output. The filter life is determined by the average daily use of your humidifier and the water hardness in your area. Areas with hard water will require more frequent replacement of the filter. It is strongly recommended that the filter be replaced at least every 2-3 months (depending on use) or when the heating element is starting to gather minerals on it.

Hands should be cleaned immediately after removal of filter. Keep away from eye's and mouth.

To Replace the Filter: Allow to cool before maintenance.

1. Switch the humidifier OFF and unplug. Remove the tank, drain any water from the base, lift out the used filter, and throw it away.
2. Remove the protective bag from the new filter and install the filter into the base (see Figure 2). Replace the tank, and plug the cord into the electric outlet. When installing the filter for the first time, wait 15 minutes for the water to flow through the filter before switching the unit ON.

You can obtain a new filter by calling 1-800-5-HOLMES in the USA or by visiting your nearest retailer or authorized service center. This humidifier takes model WMF50 replacement filter.

Figure 2

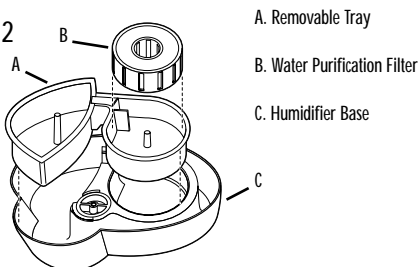

TROUBLESHOOTING - STORAGE FILTER ACCESSORIES

TROUBLE	PROBABLE CAUSE	SOLUTION
Power light not illuminated.	Unit not plugged in. Power failure.	Plug in unit. Check circuit breaker or outlet.
"Refill/Reset" light illuminated.	Water tank empty. Unit not reset after refill. Scale buildup in tray. Scale buildup in heating element.	Refill tank. Switch the knob to the "OFF" position, follow manual for Reset Instructions. Remove tray and flush out residue. Remove scale from heating element.
Mist output minimal to none.	Scale buildup in tray or heating element.	Remove scale from tray and heating element.
Water leaks from tank.	Tank rubber ring is missing or improperly placed. Cap not tight enough. Tank water hot	Remove tank cap and replace or reposition ring. Tighten the cap. Tank may be damaged call 1-800-5-HOLMES
Crack from tank.	Hot water will cause tank to pressurize. Tanks are delicate, and will crack if dropped.	Fill tank with cool water. Handle tank with care.
Film on tank.	Mineral deposits cause film on tank to buildup.	Clean/disinfect tank as instructed in weekly cleaning instructions. To order call 1-800-5-HOLMES toll free
Cloudy Water.	Mineral deposits cause film on tank to build.	Clean/disinfect tank as instructed in weekly cleaning instructions. To order call 1-800-5-HOLMES toll free

STORAGE INSTRUCTIONS

If your humidifier will not be in use for two days or more, or at the end of the season follow these instructions.

1. Clean, rinse and thoroughly dry the humidifier as directed in the weekly maintenance section. DO NOT leave any water inside the base or tray.
2. Wait for the heating element to cool completely, and then clean the heating element with a damp soft cloth.
3. Remove the tank cap. Do not store with the tank cap in place.
4. Remove and throw away the water purification filter.
5. Place the humidifier in the original carton and store in a cool, dry place.
6. Always clean the humidifier before the next season begins.
7. Order a replacement filter to start the next season.

REPLACEMENT ACCESSORY

To order call 1-800-5-HOLMES or send order to address listed on next page.

Filters

Replacement Water Purification: WMF50 \$9.99

Hygrometers

1. Digital: HHG175 \$19.99
2. Analog: HHG150 \$12.99

Cleaning Products

1. Cleanse Clean: S1710 \$5.99
(Plus shipping and handling)

WARRANTY INFORMATION

SERVICE INSTRUCTIONS

1. Do NOT attempt to repair or adjust any electrical or mechanical functions on this unit. Doing so will void the warranty.
2. If you have any questions regarding this unit's operation or believe any repair is necessary, please call 1-800-5-HOLMES to speak with a Consumer Service Representative.
3. If you need to exchange the unit, please return it in its original carton, with a sales receipt, to the store you purchased it. If you are returning the unit more than 30 days after the date of purchase, please see the enclosed warranty.
4. If you have any other questions or comments, feel free to write us:

The Holmes Group
CONSUMER SERVICE DEPARTMENT
P.O. Box 769,
Milford, MA 01757-0769

For your own records, staple or attach your sales receipt to this manual. Also, please take a moment to write the store name/location and date purchased below.

STORE NAME

LOCATION:

DATE PURCHASED:

(STAPLE RECEIPT HERE)

THREE (3) YEAR LIMITED WARRANTY

SAVE THIS WARRANTY INFORMATION

- A. The quality controls used in the manufacture of this Holmes product are to ensure your satisfaction.
- B. This Warranty applies only to the original purchaser of this product.
- C. This Warranty applies ONLY to repair or replacement of any supplied or manufactured parts of this product that, upon inspection by Holmes authorized personnel, proves to have failed in normal use due to defects in material or workmanship. Holmes will determine whether to repair or replace the unit. This Warranty does not apply to installation expenses.
- D. Operating this unit under conditions other than those recommended or at voltages other than the voltage indicated on the unit, or attempting to service or modify the unit, will render this WARRANTY VOID.
- E. Unless otherwise proscribed by law, Holmes shall not be liable for any personal injury, property or any incidental or consequential damages of any kind (including water damage) resulting from malfunctions, defects, misuse, improper installation or alteration of this product.
- F. All parts of this Holmes product are guaranteed for a period of 3 years as follows:
 1. Within the first 30 days from date of purchase, the store from which you purchased your Holmes product should replace this product if it is defective in material or workmanship (provided the store has in-stock replacement.)
 2. Within the first thirty-six months from date of purchase, subject to the conditions in paragraph H, Holmes will repair or replace the product if it is defective in material or workmanship providing it is returned to Holmes, freight prepaid, with PROOF OF PURCHASE date, together with \$7.00 for handling and return packing/shipping charges.
- G. If you have any problem with this product, please write our Consumer Service Dept., or call, 1-800-5-HOLMES.
- H. **IMPORTANT Return INSTRUCTIONS** Your warranty depends on your following these instructions if you are returning the unit more than 30 days after the date of purchase:
 1. Carefully pack the item in its original carton or other suitable box to avoid damage in shipping.
 2. Before packing your unit for return; be sure to enclose:
 - a) Your name, full address with zip code and telephone number,
 - b) A dated sales receipt or PROOF OF PURCHASE,
 - c) Your \$7.00 check for return packaging, and
 - d) The model number of the unit and the problem you are having. (Enclose in an envelope and tape directly to the unit before the box is sealed.)
 3. Holmes recommends you insure the package (as damage in shipment is not covered by your warranty).
 4. All shipping charges must be prepaid by you (as noted in paragraph F).
 5. Mark the outside of your package:

CONSUMER SERVICE DEPARTMENT
THE HOLMES GROUP, INC.
2 PULLMAN STREET
WORCESTER, MA 01606

SHIPPING AND HANDLING CHARGES: \$7.00

This warranty gives you specific legal rights, and you may have other rights which vary from state to state. The provisions of this warranty are in addition to, and not a modification of, or subtraction from, the statutory warranties and other rights and remedies contained in any applicable legislation. To the extent that any provision of this warranty is inconsistent with any applicable law, such provision shall be deemed voided or amended, as necessary, to comply with such law.