

# **MNU Ultrasonic Modbus Sensors User Manual**

# Table of Contents

<b>Introduction .....</b>	<b>iii</b>
<b>Warranty and Warranty Restrictions .....</b>	<b>iv</b>
<b>Chapter 1: Specifications and Options.....</b>	<b>1</b>
Dimensions .....	1
Specifications .....	2
Model Number Configurator.....	3
Electrical Pinout Table, Power Supply Table, and System Wiring Diagrams.....	3-5
<b>Chapter 2: Installation and Removal Procedures and Notes.....</b>	<b>6</b>
Tools Needed.....	6
Installation Notes .....	6
Electrical Installation .....	6
Mounting Instructions .....	7
Software Installation.....	7
Removal Instructions .....	7
<b>Chapter 3: Programming .....</b>	<b>8</b>
Modbus Programming .....	8
Modbus Programming via Internet with RST-5003 or LOE .....	8
Modbus Programming with RST-6001 and APG Modbus Software .....	9
MNU Modbus Register Lists .....	9-10
MNU Modbus Sensor Parameters.....	11-14
MNU Web / Independant Modbus Alarm Parameters .....	15-17
MNU Modbus Application Parameters .....	17-22
<b>Chapter 4: Maintenance .....</b>	<b>23</b>
General Care .....	23
Troubleshooting.....	23
Calibration .....	24
Repair and Returns.....	24

# Introduction

Thank you for purchasing an MNU modbus series ultrasonic sensor from APG. We appreciate your business! Please take a few minutes to familiarize yourself with your MNU and this manual.

MNU ultrasonic sensors are rugged units, with a PC/PBT housing, 1"-3" NPT threads for mounting, and a NEMA 6P rating (protects against ingress of dripping, sprayed, and submersing water). All MNU sensors are fully programmable via RST-485 Modbus communications with APG Modbus software and an APG RST-6001 unit.

## Reading your label

Every APG instrument comes with a label that includes the instrument's model number, part number, serial number, and a wiring pinout table. Please ensure that the part number and pinout table on your label match your order.

# Warranty and Warranty Restrictions

APG warrants its products to be free from defects of material and workmanship and will, without charge, replace or repair any equipment found defective upon inspection at its factory, provided the equipment has been returned, transportation prepaid, within 24 months from date of shipment from factory.

THE FOREGOING WARRANTY IS IN LIEU OF AND EXCLUDES ALL OTHER WARRANTIES NOT EXPRESSLY SET FORTH HEREIN, WHETHER EXPRESSED OR IMPLIED BY OPERATION OF LAW OR OTHERWISE INCLUDING BUT NOT LIMITED TO ANY IMPLIED WARRANTIES OF MERCHANTABILITY OR FITNESS FOR A PARTICULAR PURPOSE.

No representation or warranty, express or implied, made by any sales representative, distributor, or other agent or representative of APG which is not specifically set forth herein shall be binding upon APG. APG shall not be liable for any incidental or consequential damages, losses or expenses directly or indirectly arising from the sale, handling, improper application or use of the goods or from any other cause relating thereto and APG's liability hereunder, in any case, is expressly limited to the repair or replacement (at APG's option) of goods.

Warranty is specifically at the factory. Any on site service will be provided at the sole expense of the Purchaser at standard field service rates.

All associated equipment must be protected by properly rated electronic/electrical protection devices. APG shall not be liable for any damage due to improper engineering or installation by the Purchaser or third parties. Proper installation, operation and maintenance of the product becomes the responsibility of the user upon receipt of the product.

Returns and allowances must be authorized by APG in advance. APG will assign a Return Material Authorization (RMA) number which must appear on all related papers and the outside of the shipping carton. All returns are subject to the final review by APG. Returns are subject to restocking charges as determined by APG's "Credit Return Policy".

# Chapter 1: Specifications and Options

- **Dimensions**

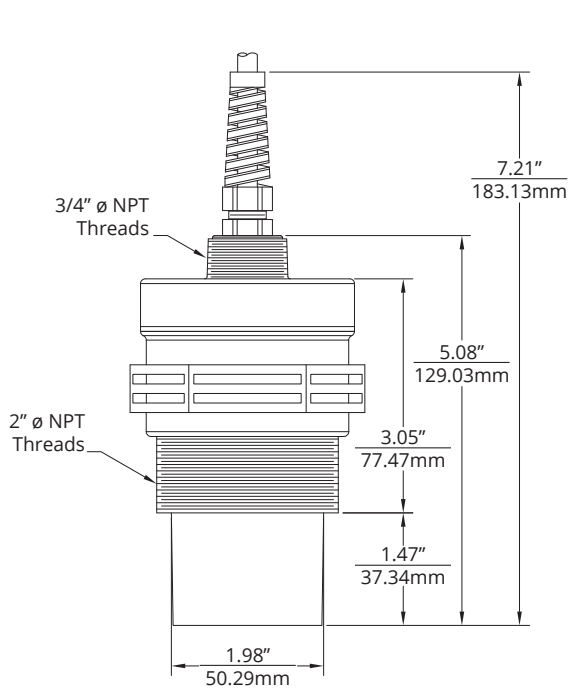

MNU-2424 & MNU-6424

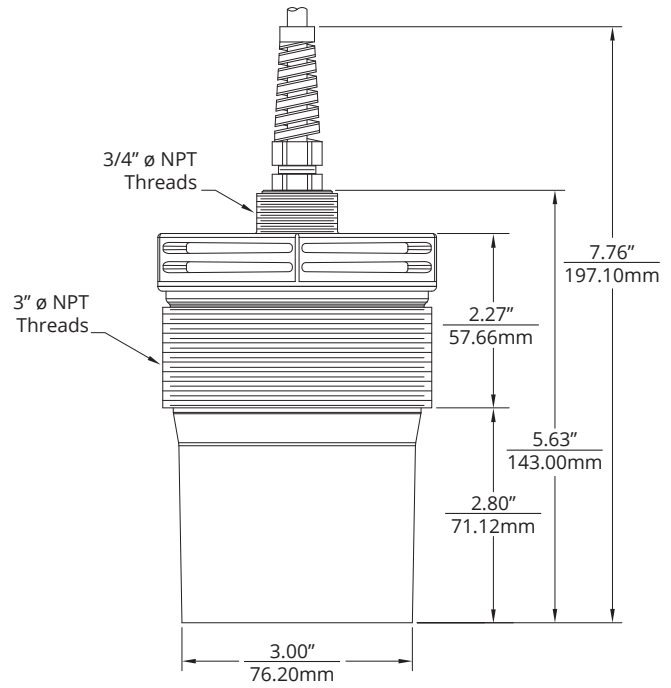

MNU-3434

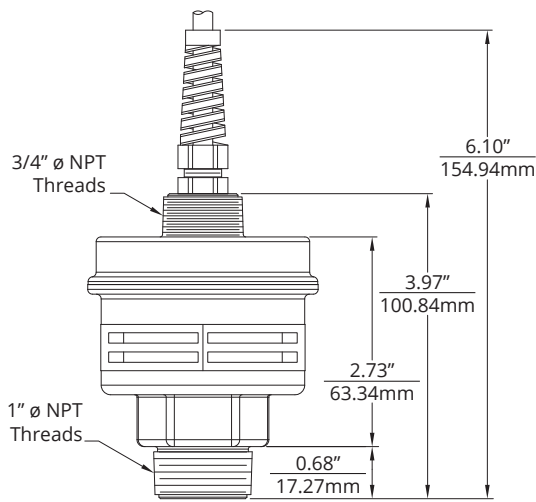

MNU-5414

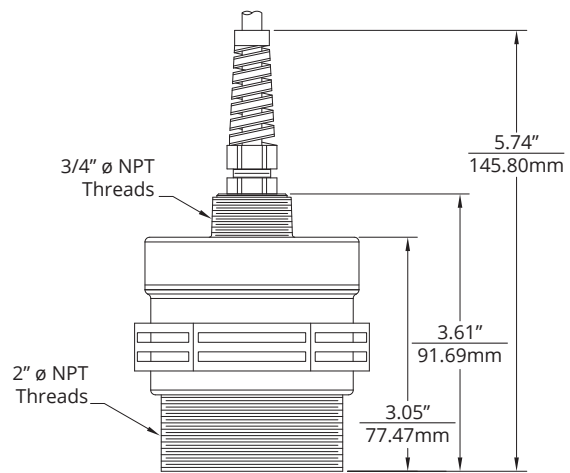

MNU-5424

## • Specifications

### Performance

Operating Range	0.3 - 6.6 ft. / 4 in. - 79 in. / 101mm - 2007mm (54x4) 0.6 - 15.0 ft. / 7 in. - 180 in. / 178mm - 4572mm (6424) 1.0 - 25.0 ft. / 12 in. - 300 in. / 305mm - 7620mm (2424) 1.5 ft. - 40 ft. / 18 in. - 480 in. / 458mm - 12192mm (3434)
Digital Output	Modbus, via RS-485
Beam Pattern	9° off axis
Transducer Frequency	43 kHz (3434) / 69 kHz (2424, 6424) / 170 kHz (54x4)
Response Time	Programmable, 10 ms minimum (100 Hz)

### Accuracy

Accuracy	±0.25% of detected range
Resolution	0.1 inch (2.54 mm)

### Environmental

Operating Temperature	-34 to 60°C (-30 to 140°F)
Internal Temperature Compensation	Yes
NEMA rating	6P

### Electrical

Operational Supply Voltage (at sensor)	12-24 VDC
Current Draw	35 mA max @ 12 VDC 20 mA max @ 24 VDC
Connection	2 Twisted Pair, or 4-pin Micro Connector

### Materials of Construction

Transducer Housing	PBT/Polycarbonate blend
Transducer Type	Ceramic, PVDF faced (2424, 54x4, 6424) Ceramic, PBT/Polycarbonate faced (3434)

### Mounting

MNU-2424	2" Ø NPT (front), 3/4" Ø NPT (rear)
MNU-3434	3" Ø NPT (front), 3/4" Ø NPT (rear)
MNU-5414	1" Ø NPT (front), 3/4" Ø NPT (rear)
MNU-5424	2" Ø NPT (front), 3/4" Ø NPT (rear)
MNU-6424	2" Ø NPT (front), 3/4" Ø NPT (rear)

- **Model Number Configurator**

Part Number: MNU -      -       
                                  A      B

**A. Model**

- **2424**      1 - 25 ft. (305mm - 7620mm); 69 kHz; 2" NPT threads
- **3434**      1.5 - 40 ft. (458mm - 12192mm); 43 kHz; 3" NPT threads
- **5414**      0.3 - 6.6 ft. (101mm - 2007mm); 170 kHz; 1" NPT threads
- **5424**      0.3 - 6.6 ft. (101mm - 2007mm); 170 kHz; 2" NPT threads
- **6424**      0.6 - 15 ft. (178mm - 4572mm); 69 kHz; 2" NPT threads

**B. Cable/Micro Connector**

- **CL**    Specify Length (6 ft. standard length + 5 ft. increments)
- **M**    Micro Connector (Mating connector cable sold separately)

- **Electrical Pinout Table, Supply Power Table, and System Wiring Diagrams**

**MNU Series Pinout Table**

		<b>Modbus</b>
Pigtail (2 Twisted Pairs)	Red	+ 24 VDC
	Black	DC Ground
	Green	A (TX-)
	White	B (TX+)
	Shield	Case Gnd
Micro Connector	1 Brown	+24 VDC
	2 White	A (TX-)
	3 Blue	DC Ground
	4 Black	B (TX+)

**MNU Series Supply Power Table**

	<b>Modbus</b>
Power Supply	12-24 VDC

## Modbus System Wiring

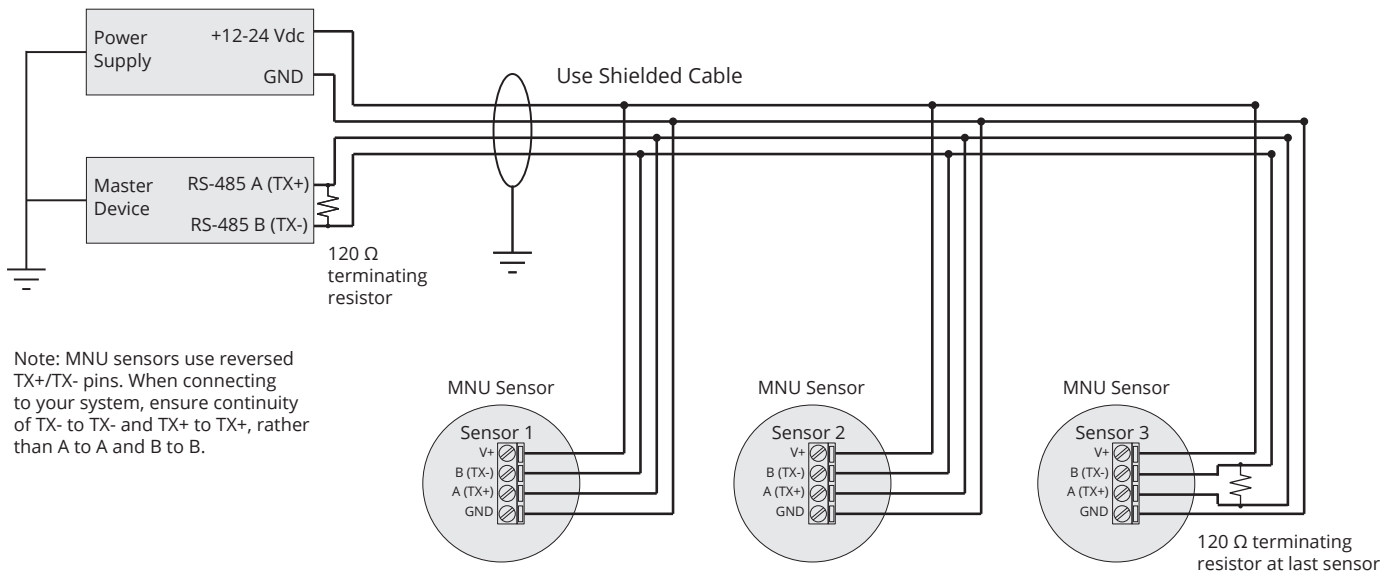

## Modbus System Wiring with RST-6001

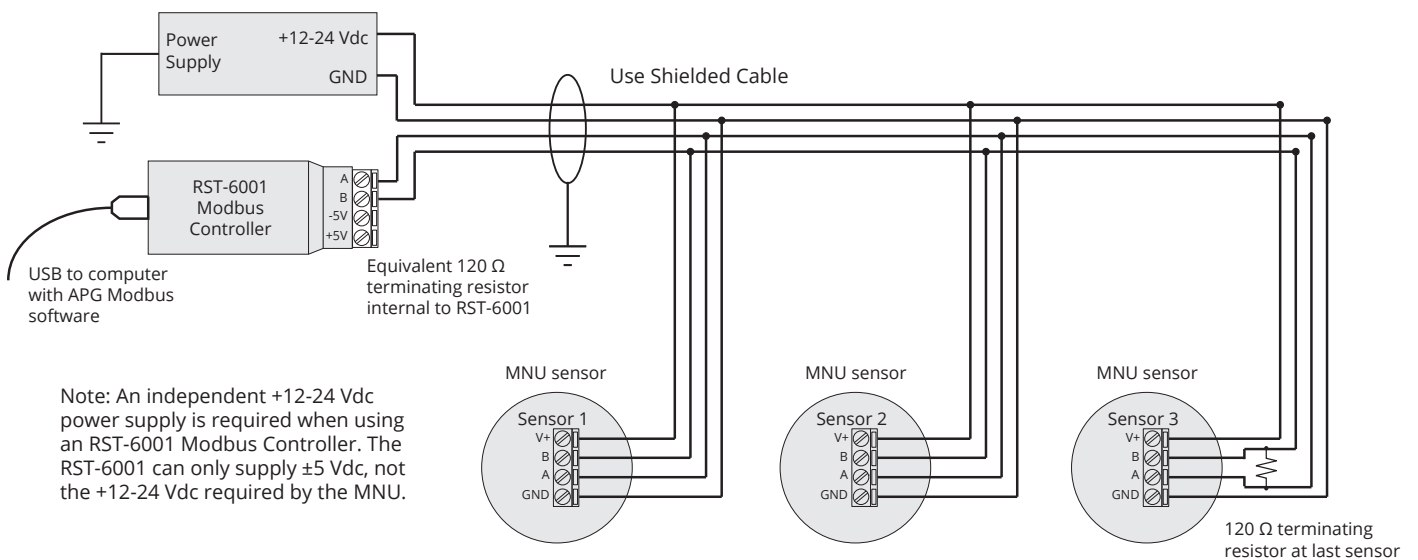



## Modbus System Wiring with RST-5003 and Independent Power Supply

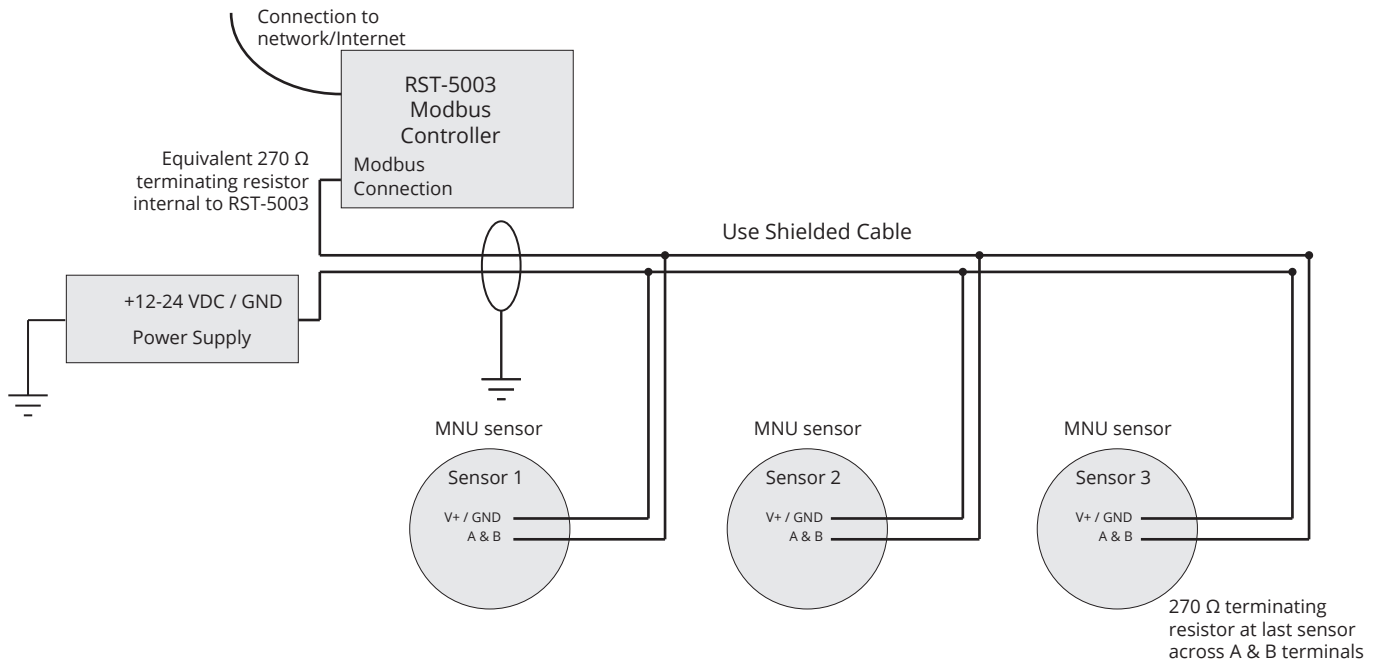

## Modbus System Wiring with RST-5003 and POE or VDC Daisy Chain

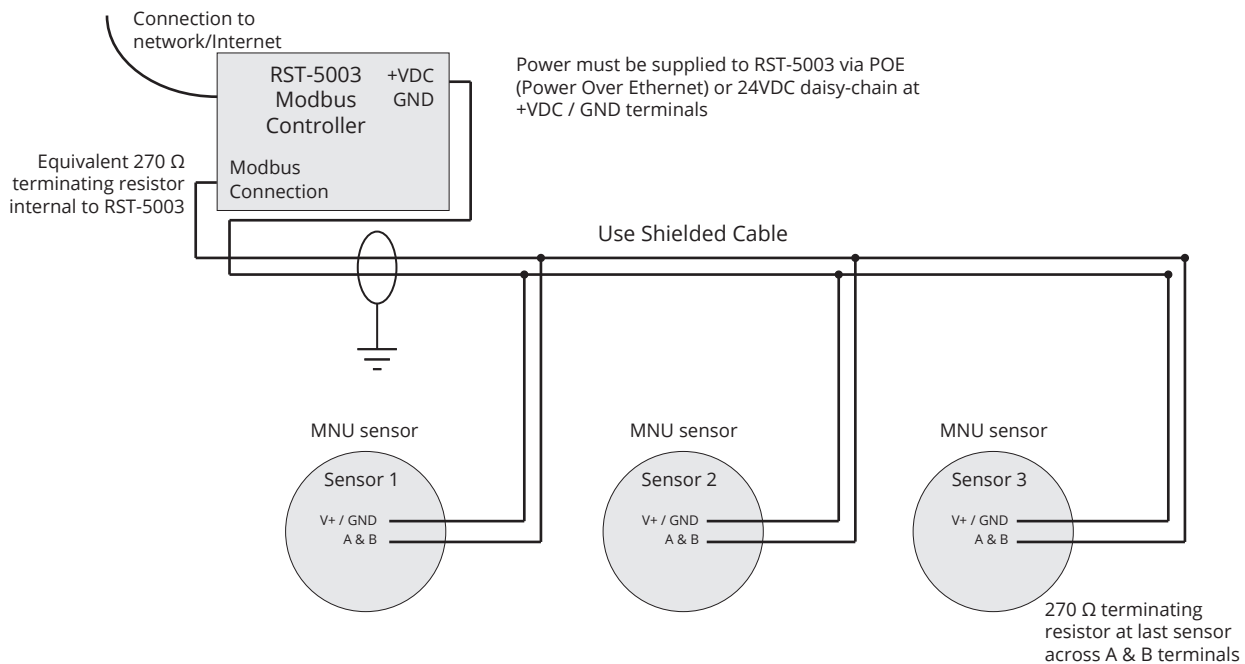

## Chapter 2: Installation and Removal Procedures and Notes

### • Tools Needed

- You should not need any tools to install your MNU. If you are using a stand pipe to mount your MNU, you will probably need tools to install the stand pipe.

### • Installation Notes

- Mount your MNU sensor so that it has a clear, perpendicular sound path to the surface being monitored. Your sensor should be mounted away from tank or vessel walls and inlets. (See Figure 2.1)
- The sound path should be free from obstructions and as open as possible for the 9° off axis beam pattern.
- If you are using a stand pipe, please see our guide to stand pipes on our website: <http://www.apgsensors.com/about-us/blog/how-to-install-a-stand-pipe>.

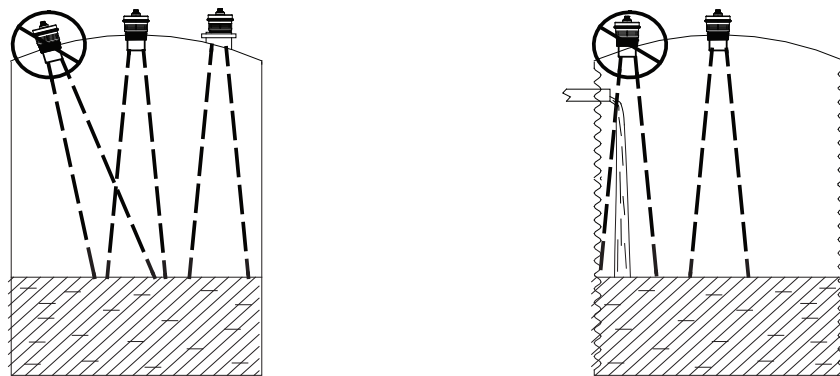

Figure 2.1

### • Electrical Installation

- Attach the wires of your MNU to your control system according to the pinout table on page 3.

**i** IMPORTANT: APG modbus equipment uses reversed TX+/TX- pins. When making connections between APG equipment, ensure continuity of A to A and B to B pins. When connecting APG modbus equipment to other systems, ensure continuity of TX+ to TX+ and TX- to TX-.

## • **Mounting Instructions**

Mounting your MNU is easy if you follow a few simple steps:

- Never over-tighten the sensor.
- Always screw in your sensor by hand to avoid cross-threading. Thread failure can be a problem if you damage threads by over-tightening them or by crossing threads.

 **IMPORTANT:** Do not over tighten! The sensor should be threaded in only hand tight.

 **NOTE:** Do not mount the sensor where the beam will intersect objects such as fill streams, pipes, ladder rungs, wall seams, or corrugated tank walls.

## • **Software Installation**

- Download the APG Modbus software zipfile from <http://apgsensors.com/support>.
- Open the zip file.
- Choose "Install" from the options at the top of the zip file window.
- The installation process will prompt you as needed to complete the installation.
- The software will create APG\_Modbus.exe which will run from a folder in your start menu titled "APG/ APG\_Modbus".

## • **Removal Instructions**

- Ensure that power to the sensor is off.
- Disconnect cable to sensor.
- Remove the sensor and store it in a dry place, at a temperature between -40° F and 180° F.
- If the sensor was installed in a hazardous location, ensure that the cable will not energize while the sensor is disconnected.

 **DANGER:** Do not disconnect equipment installed in hazardous locations unless power has been switched off or area is known to be non-hazardous.

# Chapter 3: Programming

- **Modbus Programming**

MNU modbus series sensors use standard Modbus RTU protocol (RS-485). The sensors can only operate as slave devices. Sensor default transmission settings are **9600 Baud, 8 Bits, 1 Stop Bit, No Parity**, and require a minimum delay of 300 ms between transactions to return the contents of all registers. Commands returning fewer registers will require shorter delays. See MNU Modbus Register Lists on pages 9 - 10.

 NOTE: For more information about Modbus RTU, please visit [www.modbus.org](http://www.modbus.org).

- **Modbus Programming via Internet with RST-5003 or LOE**

MNU Modbus series sensors can be programmed, controlled, and monitored via the Internet (or local Ethernet) using an RST-5003 web-enabled Modbus master controller or LOE web-enabled Modbus master sensor. One RST-5003 or LOE can control and monitor up to 10 APG Modbus-equipped sensors. Please refer to the RST-5003 User Manual or LOE User Manual for further instructions and help setting up and operating an RST-5003 or LOE and using either one to program and control MNU sensors.

 NOTE: For the RST-5003 User Manual or LOE User Manual, please visit <http://apgsensors.com/support>.

- **Modbus Programming with RST-6001 and APG Modbus Software**

APG RST-6001 Modbus Controller can be used in tandem with the APG Modbus software to program and control up to 20 MNU sensors. Through the APG Modbus software, you can monitor the raw readings from the sensor, or configure the sensor. See MNU Modbus Register Lists below.

 **NOTE:** For APG Modbus programming instructions, or to download APG Modbus software, please visit [www.apgsensors.com/support](http://www.apgsensors.com/support).

- **MNU Modbus Register Lists**

### Input Registers (0x04)

<b>Register</b>	<b>Returned Data</b>
30299	Model Type
30300	Raw Distance/Level Reading (in mm, unsigned)
30301	N/A
30302	Temperature Reading (in °C, signed)
30303-30304	Calculated (raw)
30305-30306	N/A
30307 (upper bits)	Version
30307 (lower bits)	Signal Strength
30308	N/A
30309 (upper bits)	Trip 1 Alarm
30309 (lower bits)	Trip 1 Status
30310 (upper bits)	Trip 2 Alarm
30310 (lower bits)	Trip 2 Status

 **NOTE:** The Calculated Readings will be returned without a decimal place. In order to obtain the true result, the Decimal Place setting must be taken into account.

## Holding Registers (0x03) - MNU

<u>Register</u>	<u>Function</u>	<u>Value Range</u>
40400	Device Address	1 to 247
40401	Units	1 = Feet, 2 = Inches, 3 = Meters
40402	Application Type	0 - 11
40403	Volume Units	1 - 7
40404	Decimal (Calculated)	0 - 3
40405	Max Distance	0 - 15,250 mm
40406	Full Distance	0 - 15,250 mm
40407	Empty Distance	0 - 15,250 mm
40408	Sensitivity	0 - 100
40409	Pulses	0 - 20
40410	Blanking	0 - 15,250 mm
40411	Gain Control	0 - 4
40412	Averaging	1 - 100
40413	Filter Window	0 - 15,250 mm
40414	Out of Range	1 - 255
40415	Sample Rate	10 - 1000 milliseconds
40416	Multiplier	1 - 1999 (1000 = 1.000)
40417	Offset	-15,250 - 15,250 mm
40418	N/A	
40419	N/A	
40420	Temperature Compensation	0 = No, 1 = Yes
40421	N/A	
40422-40423	N/A	
40424-40425	N/A	
40426	4 mA Set Point	*N/A
40427	20 mA Set Point	*N/A
40428	4 mA Calibration	*N/A
40429	20 mA Calibration	*N/A
40430	Trip 1 Value	0 - 15,250 (mm)
40431	Trip 1 Window	0 - 15,250 (mm)
40432	Trip 1 Type	0 - 29
40433	Trip 2 Value	0 - 15,250 (mm)
40434	Trip 2 Window	0 - 15,250 (mm)
40435	Trip 2 Type	0 - 29
40436-40437	Parameter 1	0 - 1,000,000 (mm)
40438-40439	Parameter 2	0 - 1,000,000 (mm)
40440-40441	Parameter 3	0 - 1,000,000 (mm)
40442-40443	Parameter 4	0 - 1,000,000 (mm)
40444-40445	Parameter 5	0 - 1,000,000 (mm)

\*These registers are not used by the MNU, even though they are labeled in the APG Modbus software.

## • MNU Modbus Sensor Parameters

### 40401 - Units

Determines the units of measure for the calculated reading when Application Type is set to 0, 1, or 7.

1 = Feet      2 = Inches      3 = Meters

### 40402 - Application Type

Determines the type of calculated reading performed by the sensor.

0 = Distance

1 = Depth of Level

2 = Volume of Standing Cylindrical Tank with or without Hemispherical Bottom

3 = Volume of Standing Cylindrical Tank with or without Conical Bottom

4 = Volume of Standing Rectangular Tank with or without Chute Bottom

5 = Volume of Horizontal Cylindrical Tank with or without Spherical Ends

6 = Volume of Spherical Tank

7 = Pounds (Linear Scaling)

8 = N/A

9 = Volume of Vertical Oval Tank

10 = Volume of Horizontal Oval Tank

11 = Curve Fit (Strapping Chart)

See MNU Application Parameters on pages 17 - 22 for parameter configurations for each application.

### 40403 - Volume Units

Determines the units of measure for the calculated reading when Application Type is set to 2 - 6 or 9 -11.

1 = Feet<sup>3</sup>

5 = Liters

2 = Million Feet<sup>3</sup>

6 = Inches<sup>3</sup>

3 = Gallons

7 = Barrels

4 = Meters<sup>3</sup>

### 40404 - Decimal Place

Determines the number of decimal places included in the Calculated Reading. The Calculated Reading will always be returned as a whole number.

For example, a Calculated Reading of 1126.658 (gallons, ft<sup>3</sup>, etc.) will be returned as follows:

Decimal Place = 0    Volume = 1127 (rounded to nearest whole number)

Decimal Place = 1    Volume = 11267 (divide by 10 to get true result)

Decimal Place = 2    Volume = 112666 (divide by 100 to get true result)

Decimal Place = 3    Volume = 1126658 (divide by 1000 to get true result)

## **40405 - Maximum Distance**

Sets the distance (beginning from the Zero Point) to the point where the sensor will stop looking for target signals. Targets detected beyond the Maximum Distance value will be ignored by the sensor. Maximum Distance + Offset (Holding Register 40417) cannot exceed the sensor's maximum operating range (see Specifications, page 3).

## **40406 - Full Distance**

Sets the distance (beginning from the Zero Point) to the point where the monitored vessel is considered full.

## **40407 - Empty Distance**

Sets the distance (beginning from the Zero Point) to the point where the monitored vessel is considered empty.

## **40408 - Sensitivity**

Sets the level of gain that is applied to the echo (0-100%). When operating in AutoSense, Hard-Target, or Soft-Target (see Gain Control, Holding Register 40411), Sensitivity sets an upper limit for the amplification that can be applied to the echo. If operating in Manual, this parameter sets the gain.

When using manual Gain Control, set Sensitivity to the minimum value that will allow the target to be reliably tracked through the full range of expected environmental conditions.

## **40409 - Pulses**

Sets number ultrasonic pulses per transmission burst (0-20). For Gain Control (Holding Register 40411) settings Auto Sense, Hard Target, and Soft Target, this setting limits the maximum number of pulses used by the sensor. The more pulses that are sent in a burst, the stronger the returning echo.

When operating in Manual, increase the strength of the transmission by increasing the number of pulses for detecting soft targets in damping environments. In acoustically active environments or small enclosed areas, decrease the number of pulses to reduce multiple echoes.



## 40410 - Blanking

Sets the blanking distance, which is the zone from the Zero Point of the sensor to the point from which the first echo will be accepted. While blanking distance can be used to ignore unwanted targets--such as welds, seams, pipe fittings, or gaskets--between the sensor and the closest acceptable target level, such objects generally create additional reflections and echoes, which are hard to filter out. More often, blanking distance is used for a sensor installed in a stand pipe.

## 40411 - Gain Control

Selects the control mode for the sensor's gain settings (Sensitivity and Pulses, Holding Registers 40408 and 40409). In AutoSense, the sensor automatically adjusts the sensitivity and pulses for the best quality return signal. Manual, Hard Target, and Soft Target are user controlled scenarios. In Manual, the user is in full control of sensitivity and pulses. For Hard and Soft Target, the user sets sensitivity and pulses, but the overall gain is either ramped up slowly (Hard Target) or quickly (Soft Target) by the sensor.

- 0 = Manual
- 1 = AutoSense
- 2 = Hard-Target
- 3 = Soft-Target

## 40412 - Averaging

Sets the number of qualified received signals (0-100) to average for the displayed reading. Qualified received signals are placed in a first-in, first-out buffer, the contents of which are averaged for the displayed output. The larger the number of qualified received signals being averaged, the smoother the output reading will be, and the slower the reading will be to react to quickly changing targets.

## 40413 - Filter Window

Determines the physical range (0 - 15,250 mm) of qualified received signals, based on the current reading. Signals beyond the +/- Filter Window range of the current reading will not qualify unless the average moves. Signals outside the extents of the Filter Window are written to the Out of Range samples buffer (Holding Register 40414).

## 40414 - Out of Range

Sets the number of consecutive samples outside the Filter Window (Holding Register 40413) necessary to automatically adjust the current reading and move the Filter Window.

## 40415 - Sample Rate

Sets the time delay between samples taken by the sensor (10 - 1000 ms). While shorter time delays allow for quicker sensor response times to changing levels, longer sample rate delays reduce the likelihood of echo-based false positives. Also, longer sample rates result in longer sensor life.

## 40416 - Multiplier

Calibrates the sensor for changes in the speed of sound due to variations in atmospheres. The Multiplier is shown by the values 1 - 1999, but these values are understood to represent 0.001 - 1.999. The default of 1000 (i.e. 1.000) is used for most applications. See the Calibration section of Chapter 4.

## 40417 - Offset

Sets the Zero Point of the sensor, the point from which the calculated distance is measured. When the Offset is set to 0, the Zero Point of the sensor is at the face of the transducer (See Figure 3.1). A positive setting will move the Zero Point forward, in front of the sensor face (See Figure 3.2). Setting the Offset to a negative number will move the Zero Point backward, behind the sensor face (See Figure 3.3).

In all cases, Blanking (Holding Register 40410) is measured from the end of Offset, and the effective measurement zone of the sensor begins at the forward end of Blanking. If Offset is more negative than Blanking is positive, the net difference will be a loss in sensor maximum range (See Figure 3.3).

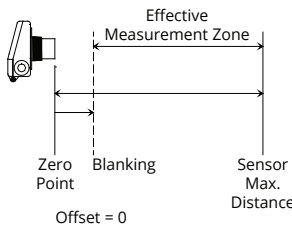

Figure 3.1

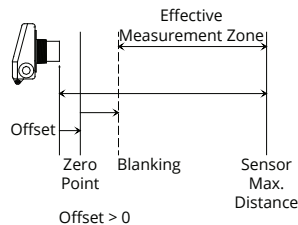

Figure 3.2

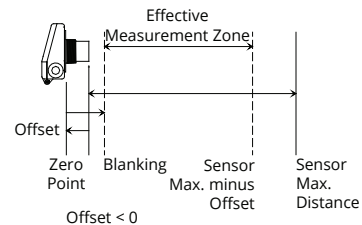

Figure 3.3

## 40420 - Temperature Compensation

Activates or deactivates the MNU's internal temperature compensation circuit (1 = On, 0 = Off). The speed of sound changes with changes in temperature, therefore changes in temperature can affect distance measurements. These effects can be minimized by activating temperature compensation.

- **MNU Web / Independant Modbus Alarm Parameters**

MNU sensors interfaced with an LOE web-enabled master sensor or an RST-5003 web-enabled master controller can be configured to generate website alarms via levelandflow.com. Refer to the LOE or RST-5003 user manuals (available on [www.apgsensors.com/support](http://www.apgsensors.com/support)) for more information.

MNU sensors do not have independent physical or electronic trip outputs. Via LOE or RST-5003 web-enabled devices, Holding Registers 40430 - 40435 can be configured to create outputs in Input Registers 30309 and 30310 that will trigger alarms through web interfaces. These registers can also be configured/monitored via RS-485 Modbus programming, but APG Modbus software cannot be used to generate such alerts or alarms.

### **40430 - Trip 1 Value**

### **40433 - Trip 2 Value**

Sets the distance (0 - 15,250 mm) to the trip position closest to the sensor face.

### **40431 - Trip 1 Window**

### **40434 - Trip 2 Window**

Sets the distance (0 - 15,250 mm) from the first trip position to the trip position farthest from the sensor face.

### **40432 - Trip 1 Type**

### **40435 - Trip 2 Type**

Sets the Trip Type for web outputs or independently-configured Modbus outputs. Trip Types are configured with two independent digits: the first for Alarm Type (1, or 2), and the second for Trip Condition (0-5, 7, or 9).

#### **Alarm Type** \_\_\_\_\_

*1\_ - Active Alarm*

Designates the active trip point as an alarm condition. To initiate an alarm whenever the Trip Type \_3 is active (on), Trip Type would be set to **13**.

#### **Alarm Type** \_\_\_\_\_

*2\_ - Inactive Alarm*

Designates an inactive trip point as an alarm condition. To initiate an alarm whenever the Trip Type \_3 is inactive (off), Trip Type would be set to **23**.

## Trip Condition

### \_0 - Near

*Near* activates the trip status whenever the target surface is closer than the Trip Value setting.

## Trip Condition

### \_1 - Exclusive

*Exclusive* activates the trip status whenever the target surface is closer than the Trip Value setting OR beyond the Trip Value + Trip Window setting.

## Trip Condition

### \_2 - Hysteresis Near

*Hysteresis Near* activates the trip status whenever the target surface moves closer than the Trip Value setting. The trip status remains activated until the target surface moves beyond the Trip Value + Trip Window setting. The trip status remains off until the target surface moves closer than the Trip Value setting again.

## Trip Condition

### \_3 - Far

*Far* activates the trip status whenever the target surface is beyond the Trip Value setting.

## Trip Condition

### \_4 - Inclusive

*Exclusive* activates the trip status whenever the target surface is beyond the Trip Value setting AND closer the Trip Value + Trip Window setting.

## Trip Condition

### \_5 - Hysteresis Far

*Hysteresis Far* activates the trip status whenever the target surface moves beyond the Trip Value + Trip Window setting. The trip status remains activated until the target surface moves closer than the Trip Value setting. The trip status remains off until the target surface moves beyond the Trip Value + Trip Window setting again.

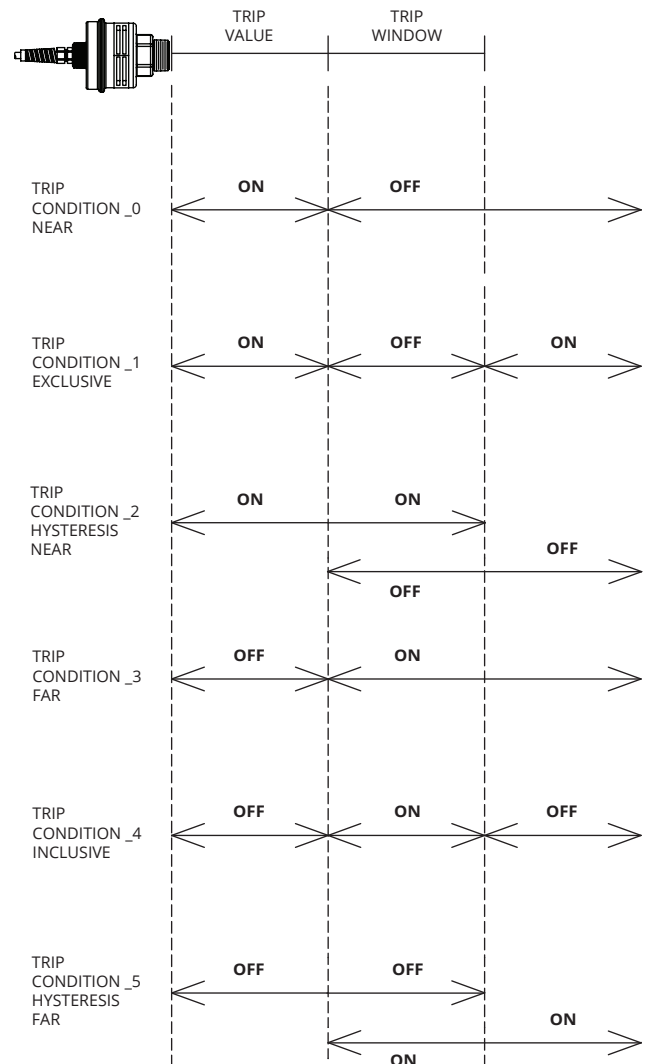

### Trip Condition

\_6 - N/A

### Trip Condition

\_7 - *Loss of Echo*

*Loss of Echo* activates the trip status whenever no target is detected within the Maximum Distance (Holding Register 40405).

### Trip Condition

\_8 - N/A

### Trip Condition

\_9 - *Rate of Change*

*Rate of Change* activates the trip status whenever a user-defined maximum rate of level change (change in distance or level divided by elapsed time) is exceeded. Trip Value (Holding Register 40430 or 40433) defines the distance and Trip Window (Holding Register 40431 or 40434) defines the time.

## • **Configuring MNU Modbus Application Parameters**

Each MNU application (Holding Register 40402) uses a specific configuration of certain Holding Registers. Below are the configurations of registers used by each application. Images defining tank dimensions assume sensor placement at the top of or above tank.

### **Application 0 - Distance**

<b><u>Register</u></b>	<b><u>Function</u></b>	<b><u>Value Range</u></b>
40400	Device Address	1 to 247
40401	Units	1 = Feet, 2 = Inches, 3 = Meters
40402	Application Type	0
40403	Volume Units	--
40404	Decimal (Calculated)	0 - 3
40405	Max Distance	0 - 15,250 mm

## Application 1 - Depth of Level

<u>Register</u>	<u>Function</u>	<u>Value Range</u>
40400	Device Address	1 to 247
40401	Units	1 = Feet, 2 = Inches, 3 = Meters
40402	Application Type	1
40403	Volume Units	--
40404	Decimal (Calculated)	0 - 3
40405	Max Distance	Less than Empty Distance
40406	Full Distance	Typically = Blanking Distance
40407	Empty Distance	0 - 15,250 mm

## Application 2 - Volume of Standing Cylindrical Tank ± Hemispherical Bottom

<u>Register</u>	<u>Function</u>	<u>Value Range</u>
40400	Device Address	1 to 247
40401	Units	--
40402	Application Type	2
40403	Volume Units	1 - 7
40404	Decimal (Calculated)	0 - 3
40405	Max Distance	Less than Empty Dist.
40406	Full Distance	Typ. = Blanking Dist.
40407	Empty Distance	0 - 15,250 mm
40436-40437	Tank Diameter	0 - 1,000,000 (mm)
40438-40439	Radius of Bottom Hemisphere	0 - 1,000,000 (mm)

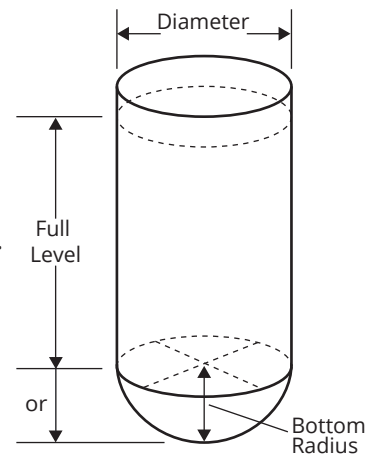

### Application 3 - Volume of Standing Cylindrical Tank ± Conical Bottom

<u>Register</u>	<u>Function</u>	<u>Value Range</u>
40400	Device Address	1 to 247
40401	Units	--
40402	Application Type	3
40403	Volume Units	1 - 7
40404	Decimal (Calculated)	0 - 3
40405	Max Distance	Less than Empty Dist.
40406	Full Distance	Typ. = Blanking Dist.
40407	Empty Distance	0 - 15,250 mm
40436-40437	Tank Diameter	0 - 1,000,000 (mm)
40438-40439	Cone Diameter (at bottom of cone)	0 - 1,000,000 (mm)
40440-40441	Length (height) of Cone	0 - 1,000,000 (mm)

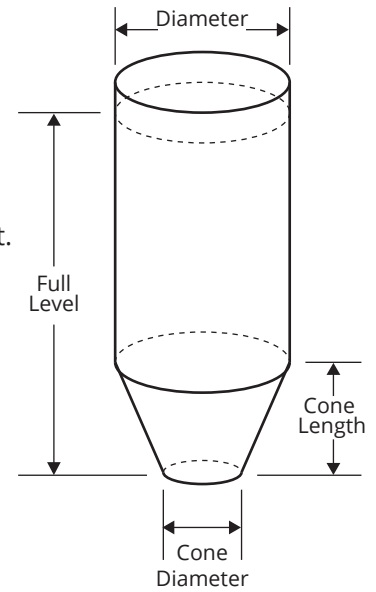

### Application 4 - Volume of Standing Rectangular Tank ± Chute Bottom

<u>Register</u>	<u>Function</u>	<u>Value Range</u>
40400	Device Address	1 to 247
40401	Units	--
40402	Application Type	4
40403	Volume Units	1 - 7
40404	Decimal (Calculated)	0 - 3
40405	Max Distance	Less than Empty Dist.
40406	Full Distance	Typ. = Blanking Dist.
40407	Empty Distance	0 - 15,250 mm
40436-40437	Tank X Dimension	0 - 1,000,000 (mm)
40438-40439	Tank Y Dimension	0 - 1,000,000 (mm)
40440-40441	Chute X Dimension	0 - 1,000,000 (mm)
40442-40443	Chute Y Dimension	0 - 1,000,000 (mm)
40444-40445	Length (height) of Chute	0 - 1,000,000 (mm)

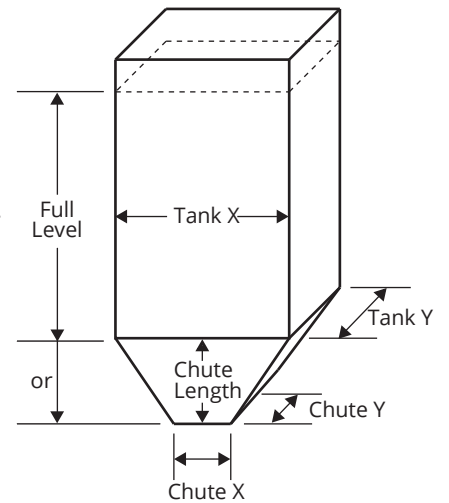

## Application 5 - Volume of Horizontal Cylindrical Tank ± Hemispherical Ends

<u>Register</u>	<u>Function</u>	<u>Value Range</u>
40400	Device Address	1 to 247
40401	Units	--
40402	Application Type	5
40403	Volume Units	1 - 7
40404	Decimal (Calculated)	0 - 3
40405	Max Distance	Less than Empty Dist.
40406	Full Distance	Typ. = Blanking Dist.
40407	Empty Distance	0 - 15,250 mm
40436-40437	Tank Length	0 - 1,000,000 (mm)
40438-40439	Tank Diameter	0 - 1,000,000 (mm)
40440-40441	Radius of End Hemispheres	0 - 1,000,000 (mm)

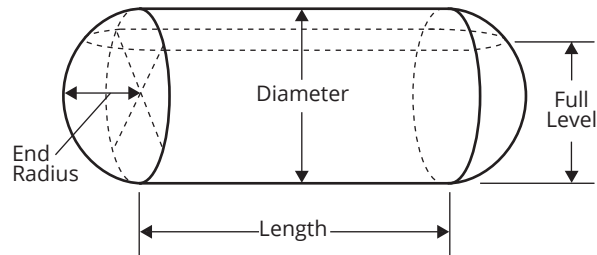

## Application 6 - Volume of Spherical Tank

<u>Register</u>	<u>Function</u>	<u>Value Range</u>
40400	Device Address	1 to 247
40401	Units	--
40402	Application Type	6
40403	Volume Units	1 - 7
40404	Decimal (Calculated)	0 - 3
40405	Max Distance	Less than Empty Dist.
40406	Full Distance	Typ. = Blanking Dist.
40407	Empty Distance	0 - 15,250 mm
40436-40437	Tank Diameter	0 - 1,000,000 (mm)

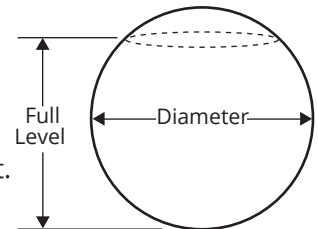



## Application 7 - Pounds (Linear Scaling)

<u>Register</u>	<u>Function</u>	<u>Value Range</u>
40400	Device Address	1 to 247
40401	Units	1 = Feet, 2 = Inches, 3 = Meters
40402	Application Type	7
40403	Volume Units	--
40404	Decimal (Calculated)	0 - 3
40405	Max Distance	Less than Empty Dist.
40406	Full Distance	Typ. = Blanking Dist.
40407	Empty Distance	0 - 15,250 mm
40436-40437	Multiplier (linear scalar)	0 - 1,000,000 (1000 = 1.000)

## Application 9 - Volume of Vertical Oval Tank

<u>Register</u>	<u>Function</u>	<u>Value Range</u>
40400	Device Address	1 to 247
40401	Units	--
40402	Application Type	9
40403	Volume Units	1 - 7
40404	Decimal (Calculated)	0 - 3
40405	Max Distance	Less than Empty Dist.
40406	Full Distance	Typ. = Blanking Dist.
40407	Empty Distance	0 - 15,250 mm
40436-40437	Tank Length	0 - 1,000,000 (mm)
40438-40439	Tank Depth	0 - 1,000,000 (mm)
40440-40441	Tank Width	0 - 1,000,000 (mm)

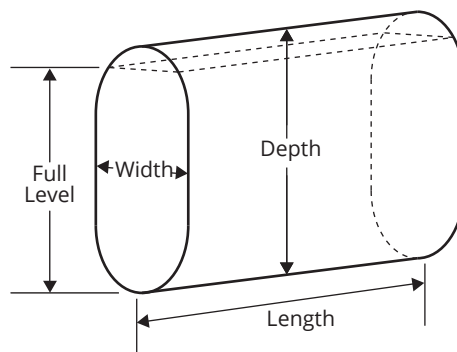

## Application 10 - Volume of Horizontal Oval Tank

<u>Register</u>	<u>Function</u>	<u>Value Range</u>
40400	Device Address	1 to 247
40401	Units	--
40402	Application Type	10
40403	Volume Units	1 - 7
40404	Decimal (Calculated)	0 - 3
40405	Max Distance	Less than Empty Dist.
40406	Full Distance	Typ. = Blanking Dist.
40407	Empty Distance	0 - 15,250 mm
40436-40437	Tank Length	0 - 1,000,000 (mm)
40438-40439	Tank Depth	0 - 1,000,000 (mm)
40440-40441	Tank Width	0 - 1,000,000 (mm)

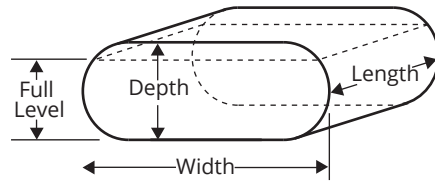

## Application 11 - Strapping Chart (Curve Fit Polynomial Values)

<u>Register</u>	<u>Function</u>	<u>Value Range</u>
40400	Device Address	1 to 247
40401	Units	1 = Feet, 2 = Inches, 3 = Meters
40402	Application Type	11
40403	Volume Units	1 - 7
40404	Decimal (Calculated)	0 - 3
40405	Max Distance	Less than Empty Dist.
40406	Full Distance	Typ. = Blanking Dist.
40407	Empty Distance	0 - 15,250 mm
40436-40437	X <sup>3</sup> Coefficient	0 - 1,000,000
40438-40439	X <sup>2</sup> Coefficient	0 - 1,000,000
40440-40441	X <sup>1</sup> Coefficient	0 - 1,000,000
40440-40441	X <sup>0</sup> Coefficient	0 - 1,000,000

# Chapter 4: Maintenance

- **General Care**

Your MNU ultrasonic sensor is very low maintenance and will need little care as long as it was installed correctly. However, in general, you should:

- Avoid applications for which the sensor was not designed, such as extreme temperatures, contact with incompatible corrosive chemicals and fumes, or other damaging environments.
- Inspect the threads whenever you remove the sensor from duty or change its location.

- **Troubleshooting**

Should you have problems with your MNU, here are some troubleshooting steps.

- Check the received signal strength (Input Register 307). If the signal strength is low, alternately increase Pulses and Sensitivity (Holding Registers 40409 and 40408) until the signal strength improves.
- Ensure Temperature Compensation (Holding Register 40420) is On (set to 1).
- Set the Gain Control to AutoSense (Holding Register 40411).
- Ensure that Blanking (Holding Register 40410) is accurately set to account for any unwanted targets between the sensor and the closest acceptable target.

## • Calibration

This procedure uses targets at known distances to calibrate the sensor's accuracy. A wall or other large, flat object is recommended for the long range target.

- Point the sensor at a target at a known distance near the maximum range of the sensor, 25' for a single solid object (See Figure 4.1).
- Adjust the Multiplier value until the distance reading on the sensor matches the actual measured distance to the target (Holding Register 40416).
- Point the sensor at a target near the minimum measurement range, 1' plus any Blanking distance (See Figure 4.2).
- Adjust the Offset value until the distance reading on the sensor matches the actual measured distance to the target (Holding Register 40417).
- Repeat previous two steps until no further adjustment is required.



Figure 4.1

Figure 4.2

## • Repair and Returns

Should your MNU ultrasonic sensor require service, please contact the factory via phone, email, or online chat. We will issue you a Return Material Authorization (RMA) number with instructions.

- Phone: 888-525-7300
- Email: [sales@apgsensors.com](mailto:sales@apgsensors.com)
- Online chat at [www.apgsensors.com](http://www.apgsensors.com)

Please have your MNU sensor's part number and serial number available. See Warranty and Warranty Restrictions for more information.





**Automation Products Group, Inc.**

Tel: 1/888/525-7300 • Fax: 1/435/753-7490 • [www.apgsensors.com](http://www.apgsensors.com) • [sales@apgsensors.com](mailto:sales@apgsensors.com)