



Instruction Manual

Hybrid – Charge Controller HYBRID 1000 with LCD-multi-function-display



WWW.
silentwindgenerator.com

Email: info@silentwindgenerator.com

Phone: +351253572763

Congratulations, you have bought a high-quality SILENTWIND hybrid charge regulator HYBRID 1000

Before first using this gadget please carefully read this manual.

General information:

The Silentwind-Charge controller HYBRID 1000 is a combined wind and solar charge regulator with an inbuilt micro-controller. The HYBRID 1000 was especially developed for the Silentwind Generator and enables you additionally to install solar panels up to a wattage of 550 Watt peak or to a max. current of 40A.

Consumers with a maximum current of 15 Amps that are connected to the deepcycle output can be automatically switched off or on by a deep cycle protection function.

All operating parameters can be seen on an LCD-display.

You can adjust the charge regulator with 5 touch keys on the right and left of the LCD-display.

A LED's on top of the controller additionally informs you about the operating status "brake active".

A LED on top of the case, below the LCD-display, additionally informs about the either manually or automatically activated brake function.

A thermally switched vent provides the correct operating temperature.

The Silentwind Generator generates 3phase AC-voltage. In the charge controller AC is transformed to DC voltage. 12 or 24 voltage is automatically detected after the first installation. All types of lead batteries (Gel, AGM and acid) can be charged.

The suitable maximum charge voltage - depending on the type of battery - must be adjusted in the Setup.

The charge-controller is

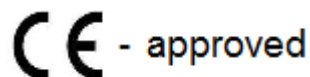

Advise:

Please keep in mind that liquid acid batteries can emit dangerous explosive gas. If the place where you mount the charge controller is close to these batteries, ensure efficient ventilation. Gel or AGM batteries are normally maintenance free and do not emit gas if properly charged.

Always make sure charge controller is mounted in a dry and as cool as possible place.

Contents:

1. wiring diagramm	4
2. technical data	4
3. components of the charge controller	5
3.1 Front side	5
3.2 Back side	6
3.3 LCD – display	6
4. Mounting the charge controller	7
4.1 Mounting by holding brackets	7
4.2 Mounting in a slurry wall trench	7
5. Cable – cross section	8
6. Installation and Connection of the charge controller	8
7. External Stop Switch	10
8. Connecting solar panels	10
9. Programming charge controller	11
10. Programming instruction	12
10.1. Operating keys	12
10.2. Battery voltage and charge current	12
10.3. Charge cut-off voltage	13
10.4. Charge amount in kilowatt hours (kWh)	13
10.5. Current charging power wind	13
10.6. Current charging power solar	13
10.7 Consumer settings	14
10.8 Brake adjustments	15
10.9 Night lamp parameters	15
11. Troubleshooting	17

1. wiring diagramm

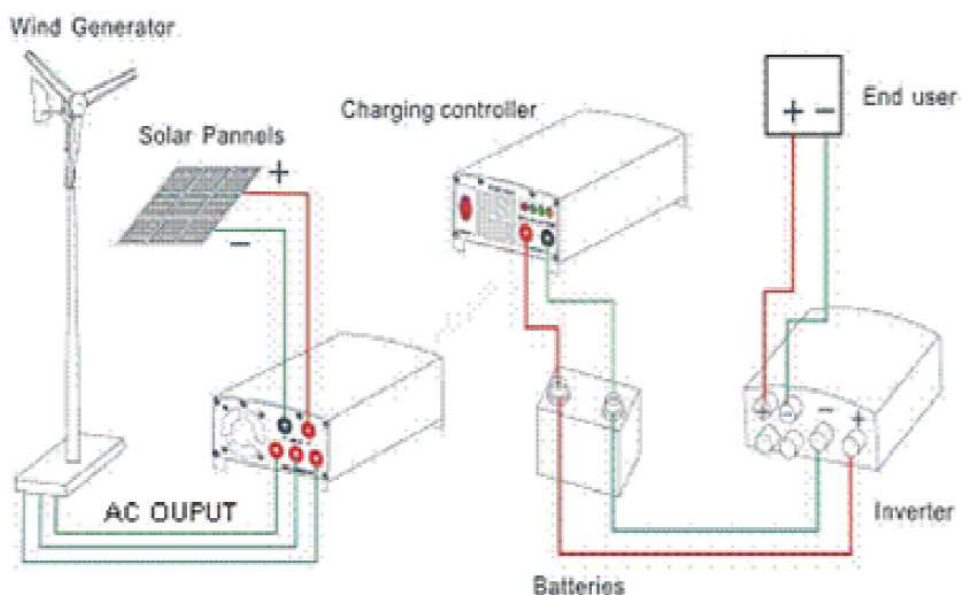

2. Technical data

hybrid-charge controller type	HYBRID 1000
Battery system voltage (automatically detected)	12 or 24 Volt
Max. power input of the wind generator	600 W
Max. current input of the wind generator	40A
Max. power input of the solar panel	550Wp
Max. current input of the solar panel	40A
Max. open circuit voltage input of the solar panel	50VDC
Max. total charge current	80 A
Max. switch off current at LOAD-output (Load)	15 A
Max. voltage adjustable for the battery types	acid, gel or AGM
Dimensions (LxWxH) in mm	270 x 130 x 80
Weight	1,50 kg
Suitable for	acid, gel and AGM
Warranty	24 months
Features	
Thermically switched vent	automatically
Cable connection	screw terminals
Integrated electronic brake	charge limitation, storm brake
Integrated manual brake switch	service
LCD-display of all relevant working data	W, A, V/Ah, kWh, Ah
External stop switch	Plug connector

3. Components of the charge controller

3.1 Front side

On the front of the charge controller there are screw terminals to connect the battery. There are also screw terminals for the automatically switched load output (user output) as well as the brake switch to activate manually the brake function.

Please note that the brake switch in position “I” means that the brake is activated / switched on manually, but it does not mean that the wind generator is switched on.

The brake switch does not totally stop the blade rotation. The blades will still turn slowly. If the brake is manually or electronically activated, the LED “brake” will lit up. The brake switch should be manually activated in case of storm, maintenance or if you want to work close by the Silentwind Generator.

For **automatic** brake mode please switch position “0” (“RELEASE”)

Front view:



3.2 Back side

On the backside of the charge controller there are screw terminals to connect the wind generator and the solar panels.

Rear view:



3.3 LCD-Display

On the top of the charge controller there is an LCD-display that is necessary to adjust the charge controller and that shows you all operating data during the working process.

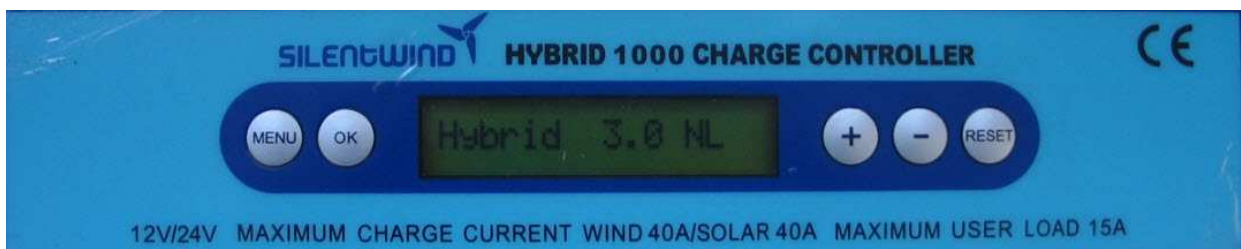

4. Mounting the charge controller

The charge controller can be mounted in various ways. We suggest these possibilities:

4.1 Mounting with holding plates (brackets)

picture 1:



Mount the charge controller with the enclosed holding plates as shown in picture 1. Use suitable screws - depending on the mounting material. Screws are not included in delivery.

4.2 Mounting in a slurry wall trench

picture 2:



As you can see from picture 2 there are 4 mounting holes on the back of the charge controller. Use filister head screws with appropriate (suitable) diameter and screw them into the mounting surface according to the measurements shown in the picture above. Don't screw them completely into the mounting surface. Place the mounting holes over the screws and slide the charge controller into the 4 slurry wall trenches. Screws are not included in delivery.

5. Cable cross section

As you can see from the wiring diagram in paragraph 1 a 3-pole cable with suitable cross section must be wired from the Silentwind-Generator to the charge controller. The charge power gets from the charge controller to the batteries through two wires (on the AC entrance through three wires) Therefore the cross section of the two wires on the DC output should be larger, we recommend a minimum cross section of 10mm².

See below table to find the correct cable cross section:

System voltage 12 Volt

Distance from wind generator to the charge controller in m	0 - 9	10 - 19	20 - 29	30 - 44	45 - 69	70 - 110
Cable cross section mm ²	6	10	16	25	35	50
AWG	10	8	6	4	2	1
Distance from the charge contr. to the battery in m	0 - 9	10 - 19	20 - 29	30 - 44	45 - 69	70 - 110
Cable cross section mm ²	16	25	35	---	---	---
AWG	6	4	2	---	---	---

System voltage 24 Volt

Distance from wind generator to the charge controller in m	0 - 9	10 - 19	20 - 29	30 - 44	45 - 69	70 - 110
Cable cross section mm ²	2.5	4	6	10	16	25
AWG	14	12	10	8	6	4
Distance from the charge contr. to the battery in m	0 - 9	10 - 19	20 - 29	30 - 44	45 - 69	70 - 110
Cable cross section mm ²	16	25	35	---	---	---
AWG	6	64	2	---	---	---

6. Installation and connection of the charge controller:

The charge controller should be mounted close to the battery in a ventilated and cool location which enables you to read the information shown on the LCD display and to operate the manual brake switch easily.

Safety advice:

Especially acid batteries can emit gas when charging. Therefore the charge controller must not be installed close to those batteries. In case of high concentration of dangerous gas there is a risk of explosion. Please note the safety regulations, -advice of the battery producer.

If the acid batteries are equipped with ventilation pipes to the exterior or if the storage room of the batteries is otherwise ventilated, the charge controller can be installed close to the batteries.

Please find a sketch of the wiring diagram in the paragraph 1 of this manual.

Make sure that you fix the wires properly to prevent them from getting loose due to vibrations. Fix the plastic screw nuts sufficiently to ensure electric contact.

We recommend the use of the enclosed wire kits

3 x H07V-K 4mm², red (input of 3 phases of the wind generator)

1 x H07V-K 6mm², red (output "+" to battery)

1 x H07V-K 6mm², black (output "-" to battery)

Connect the free end of the connecting wire with your wires coming from the wind generator and the battery with suitable insulating screw joints.

In case you do not use the connecting wires we recommend the use of crimp type cable sockets to fix your wires directly to the charge controller. After having fixed the crimp type cable sockets with the bared wires these can be fixed to the cable sockets.

It is most important that you first connect the charge controller to the battery with the right polarity.

Please connect the enclosed fuse (50Amp.) close to the battery in the positive wire. The fuse is only included in delivery if you buy a wind generator (not only a charge controller).

Please take note:

If you wish to connect solar panels with more as 200Wp (20A) you must acquire a stronger circuit breaker.

After the connection of the battery you can connect the Silentwind Generator, the solar panel and if required a load output with maximum 15A. On the 3-phase output wires of the Silentwind you need not to pay attention to polarity.

If you want to connect 24 volt batteries to the charge controller, make sure that the voltage of the batteries is above 20 Volt. Otherwise the charge controller will detect a 12 volt battery system.

Attention: *The confusion of Plus and Minus will definitely destroy your charge controller. In that case warranty is gone.*

If there is sufficient windspeed when connecting the Silentwind Generator, this will immediately generate electric power at the end of the 3 AC-wires without being connected to the charger. Therefore we recommend to block the Silentwind Generator blades with a rope before connecting the wires to the charger. The 3 AC output wires must be connected to the 3 screw terminals on the back of the charge regulator. (see paragraph 3.2). In a 3 phase AC system the connection order / polarity does not matter.

In case you want to connect additional solarpower (max. 550Wp or 40A) to the charge controller, this should be done by using the PV screw terminals.

Please make always sure that you do not confuse polarity. You can find the connection diagram in paragraph 8.

7. External Stop Switch

You can connect an external stop switch to the charge controller (see picture rear view on page 6). To connect this stop switch to the charge controller, please use a standard chinch connector 3.5mm 2 poles. The cable cross section should be 2x0.5mm². You can choose the type of stop switch suitable to your instrument panel.

8. Connecting solar panels

The charge controller Hybrid 1000 is a hybrid controller both for wind and solar energy. Solar panels with a max power of 550 Wp / 40 A can be connected, See technical details page 4.

Connect the solar panels according to the following sketch.

12 volt system:

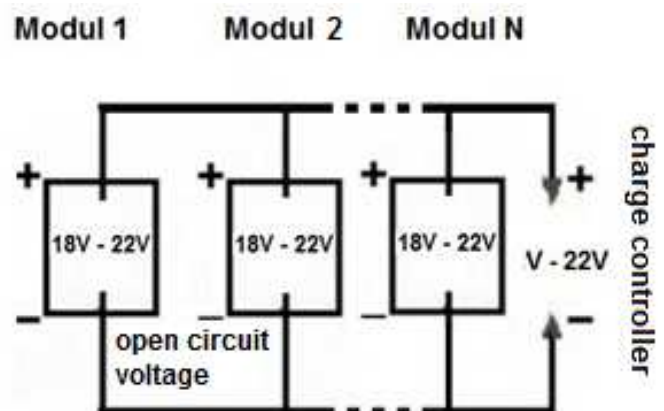
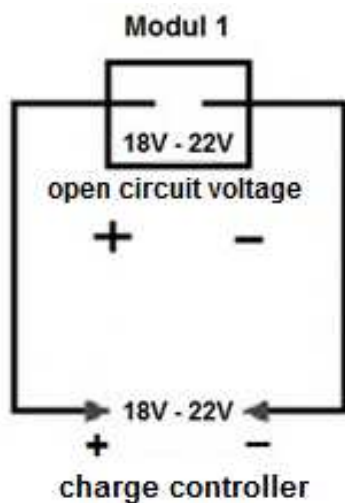

24 volt system:

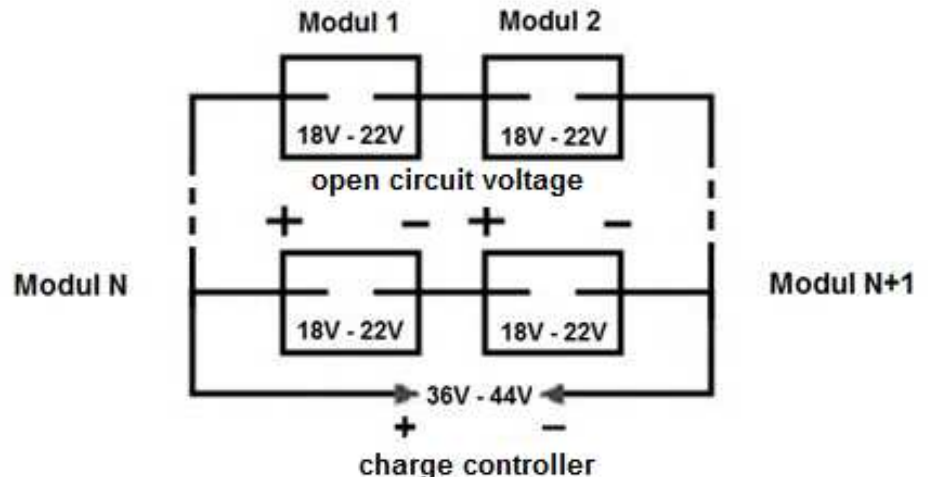
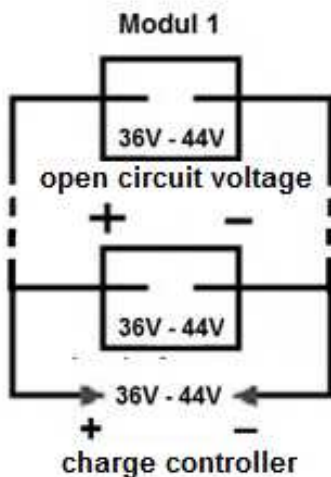

9. Programming charge controller

Before first using the charge controller it must be adjusted to the type of battery (acid, gel, AGM) you want to use (see paragraph 9).

At first you have to programme the max. possible voltage according to the instructions of the battery manufacturer in step “Charge Off” (paragraph 9.3). Secondly you have to programme the requested switch off current at the step “Break On” (paragraph 9.8).

We also recommend to make use of the additional adjustments according to your individual requirements.

If the point of maximum voltage is reached, the Silentwind Generator will stop for 20 minutes.

The break mode of the charge regulator generates internal rising temperatures that are thermically detected. Therefore the break time of the Silentwind Generator will be increased in high wind speeds until the internal temperature is reduced by the automatically switched vent.

For this reason the charge controller should be installed on a place as cool as possible. Never install the controller at direct solar radiation or sunlight.

A special feature of this charge controller is that you can programme the break function. If the maximum possible voltage – according to the type of battery – is reached, the charge controller will switch of the Silentwind Generator. Additionally the maximum charge current can be adjusted (see chapter settings page 12)

This means that the Silentwind Generator can also be operated with a larger battery capacity. If a large battery capacity is discharged, a higher charge current will flow in high wind speeds. As you can set the maximum charge current you can prevent overheating of the charge controller. As described in step “Break On” you can reduce the max. charge current according to the requirements.

Advice:

If the capacity of the batteries is less than 150 Ah, or old batteries have lost their original capacity, the point of max. voltage can be reached very fast although the battery is not fully charged yet. In this case it can be useful to connect an electric consumer to the Load-output, as this will reduce the voltage and thus prevent that the break mode is activated too early.

10. Programming instruction

10.1 Operating keys

The charge regulator has 5 operating keys on the top:

- With the **menu key** you move through the menu.
- With the **OK key** you move back.
- with the "+" and "-" keys you can change the different parameters
- With the **RESET key** the inbuilt micro-processor is restarted, your settings will not be resetted.

10.2 Battery voltage and charge current

The system-voltage is automatically detected as soon as the charge regulator is connected to the battery.

Please only connect batteries that are sufficiently charged. If the battery of a 24V system is discharged, it is possible that the charge controller detects a 12 V system.

After the **first connection** the display shows the following data:

The display shows:

Hybrid 3.0 NL = 12V system voltage

Hybrid 3.0 NH = 24V system voltage



In the display mode you can see above the battery voltage and the charge current. The total current (wind and solar) is shown.

10.3 Charge cut-off voltage



In the display mode shown above „charge off“ you can set the max. possible voltage of your battery with the buttons “+” and “-“ . Please note the instructions of the manufacturer of the batteries. The maximum possible voltage is dependent on the system voltage (12/24V) and the type of battery (acid, Gel or AGM)

10.4 Charge amount in Kilowatt hours (kWh)



Charge shows you the amount of kWh have been loaded into the battery. This parameter is updated every 10 seconds.

10.5 Current charging power wind



This shows you the wattage flowing at the moment (wind generator).

10.6 Current charging power solar

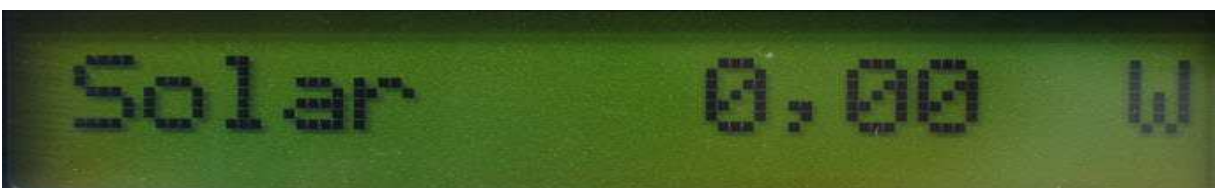

This shows you the wattage flowing at the moment (solar panels if available).

10.7 Consumer settings



You can also connect a consumer to the screw terminals of the load output and define when the consumer should be switched on and off. The consumer is called user in the picture above. This shows you how many amp-hours the user has taken.



With the button „+“ and „-“, you can define the voltage when the charge regulator should switch off the consumer. Please note that this must not be higher than 15 Amp.



User on defines the voltage when the consumer can be switched on again. As the voltage of the battery increases when switching off the consumer this will steadily switch on and off the load output if this value is not high enough. This function can also be used with smaller batteries.. So that the charge voltage is not detected too fast, you can connect a consumer additionally. This avoids that the brake will be activated too early.



This setting shows how much amps the consumer that is connected to the load output is using.

10.8 Brake adjustment



With +/- you can set the current when you want to stop the Silentwind Generator. This prevents overheating, especially with big battery banks and high loading currents. This function can also be used to reduce the RPM of the Silentwind Generator.

You can calculate the max. charge current value as follows: The max. power of the Silentwind Generator 400 Watts divided by the max. cut-off voltage e.g. 14,4 Volt at a AGM battery. The max. possible charge current in this example is $400VA / 14,4V = 27,7Amp$.

10.9 Night lamp parameters



Attention! This parameter works only with connected solar panels. The charge controller recognizes thru the solar panels if it is day or night and switch the lights on or off.



If the charge controller is correctly connected, the manual break switch on the front of the charge controller can be switched in position “0”. The Silentwind Generator will then start to turn faster until the charging process starts.

The charge controller now starts operating and monitors all special settings that you have programmed according to the type of battery and the instructions of the battery manufacturer (see examples for settings).

Safety advice:

*Please **never** disconnect the battery wires while the Silentwind Generator is charging. This will immediately destroy the charge controller. If you want to measure the current flowing, an amp-meter must be installed in the positive battery wire. Mind the polarity of the amp-meter. The flowing current can be seen at the LCD-display.*

11. Troubleshooting

The blades of your Silentwind Generator are turning too slowly

- The manual stop switch of the charge controller is in position „I“ (“BRAKE”).
- Connecting the wires possibly caused a short circuit between the wires.
- The wind speed is too low.
- The fuse connected to the battery is gone.
- Your Silentwind Generator or the charge regulator has an internal problem. Please contact your dealer.

In order to find the mistake you have to check the installation chain starting at the 3 wires of the Silentwind Generator connected to the charge controller. In case the Silentwind Generator does now start (without connection to the charge controller) the failure is between charge regulator and battery. BE CAREFULL, don't touch the end of the cables because of the electric power that occurs at these ends. If the Silentwind Generator continues to turn slowly, the failure is between charge controller and Silentwind Generator.

Mind the recommended cross section of the wire as well as the recommended minimum capacity of the battery that you want to charge.

If the Silentwind Generator generates too little power

- The wind speed is too low, see the performance diagrams shown in the manual of the Silentwind. *The wind speed measured on top of the mast is higher than at the position of the wind generator!*
- Turbulences by obstacles in the wind direction or the location is unsuitable, mast too short.
- The wire cross section is not in line with the length of the wires installed. (see page 3).
- The battery-capacity is below 100Ah so that the maximum possible voltage is generated too fast.
- The battery is too old and has lost capacity so that the maximum power voltage is achieved too fast.

Enjoy collecting regenerative power. You contribute protecting the environment and saving your money !

Your Silentwind Team



Rulis Eléctrica, Lda.
Loteamento Industrial de Linhares, Lote 19
PT-4805-486 Santo Estevão de Briteiros / Guimarães
Portugal
VAT/Contribuinte / EORI-N. PT 502 995 530
Tel. 00351-253-572763
Fax 00351-253-572764
Tm/Handy 00351 96 790 79 33
e-mail: info@silentwindgenerator.com
site: www.silentwindgenerator.com