



# **SY210NT Serial Controller Operation Manual**

**Version 2.3**

**© 2005 by SYRIS Technology Corp.**

# User Manual

<b>Item</b>	<b>Content</b>
1.	Introduction
1.1	SYNT Serial Product
1.2	System Configuration
2.	Wiring Connection
2.1	Controller to PC
2.2	Controller to Card Reader
2.3	Controller to Other Module
3.	System Setup
3.1	Power Up Procedures
3.2	System Setting
3.3	PCB Layout of Typical SY210NT Controller
4.	Programming
4.1	Set Controller Date / Time
4.2	Card Process
4.3	Set DI Parameter
4.4	DO Parameter Setting
4.5	Anti-PassBack Setting
4.6	Set Door Lock-Release Time
4.7	Set Timer, TimeZone, Holiday TimeZone
4.8	Set Application Set [APPSET]
4.9	Set Flow Process
4.10	Flow Chart
4.11	Typical Wiring Connection
5.	Technical Information
5.1	SY210NT Controller Specification
5.2	SYWIN95A Access Control Software
5.3	SYRIS Proximity Reader
5.4	Proximity Card
5.5	Power Consumption

# 1. Introduction

## 1.1 SY210NT Series Product

1. SY210NT2/NT4 Card Access Controller
2. SYRDS1/L5... Card Reader
3. MDDIDO Input/Output Module
4. Printer Interface Module
5. Proximity Card
6. Other Application Module

## 1.2 System Configuration

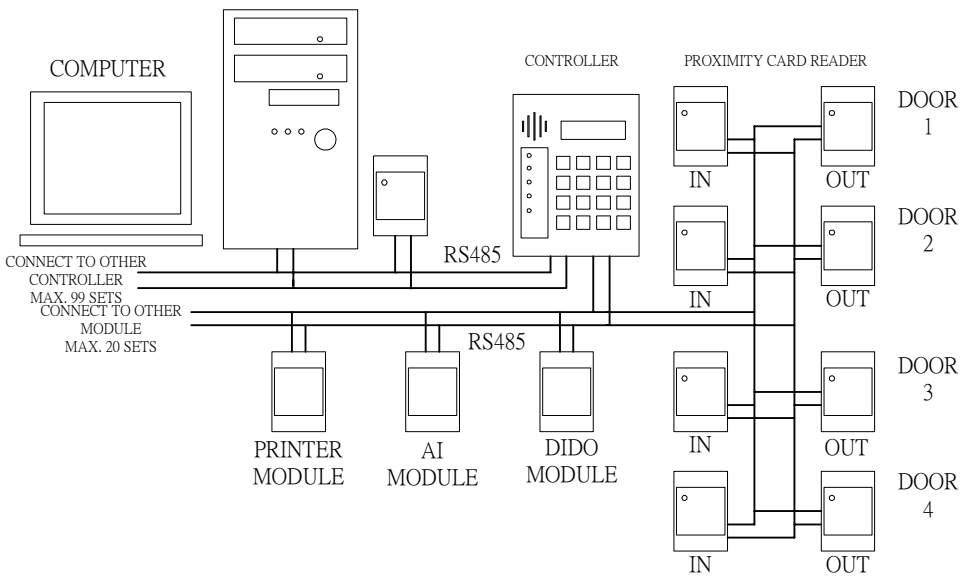

Figure 1.1 System Configuration

## 2. Wiring Connection

### Type Of Connection

- a. Controller to Personal Computer
- b. Controller to Card Reader
- c. Controller to Extension Module
- d. Input/Output Contact Build in Controller

Detail Connection as follow :

### 2.1 Controller To PC

Controller link to PC by RS485 Communication module, Maximum distance from PC to Controller is 1 KM. A single

Controller M4 Connector	SYLINK Connector
PIN 1 4A -, Blue Color	PIN 3 Green Color
PIN 2 4A+, Purple Color	PIN 2 Yellow Color
PIN 5 GND, Black Color	PIN 1 Black Color

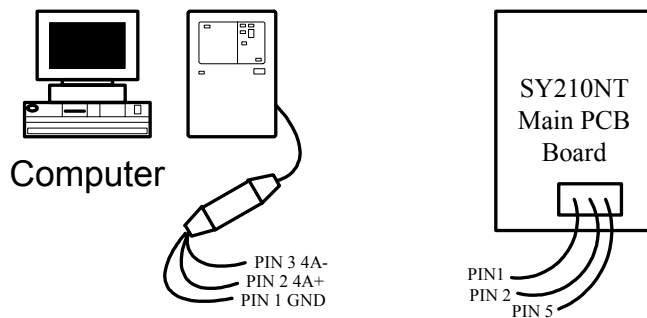

Figure 2.1 Connection from SY210NT to PC

Caution : RS485 Communication Wire must be Twisted Screen Cable, grade AWG18~24 depend on distance.

## 2.2 Controller to Card Reader

Controller link to Card Reader by RS485 Communication mode, max distance from Controller to Card Reader is 1 KM. A single controller can connect up to max. 8 Readers.

Controller M4 Connector	Reader Wire
PIN 3 -- 4R-, Grey Color	Green Color 4R-
PIN 4 -- 4R+, White Color	Yellow Color 4R+
	Red Color +5~12VDC
	Black Color 0VDC

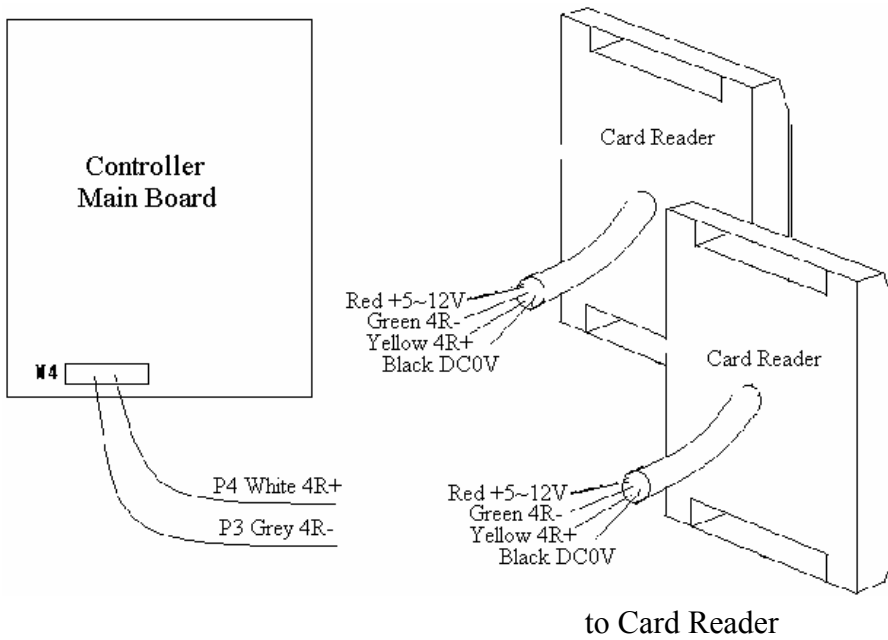

Fig 2.2 Connection from Controller to Card Reader

Caution : RS485 Communication Wire must be Twisted Screen Cable, grade AWG 18~24, depend on distance.

## 2.3 Controller to Other Module

### 2.3.1 MDDIDO Module

DIDO Module consist of :

- Power Supply ..... DC : 5 ~ 12 V
  - RS485 Line ..... Link to Controller 4R+, 4R-
  - DO Ouput ..... 4DO, 8DO, 16DO
  - DI Input ..... 4DI, 8DI,16DI
- DO ... Dry Contact Output  
 DI ... Dry Contact Input  
 Stalus indicate LED : LED 1 ~ 4 --- DO Output  
 LED 5 ~ 8 --- DI Input  
 LED 9 ---RS485 (Blinking)

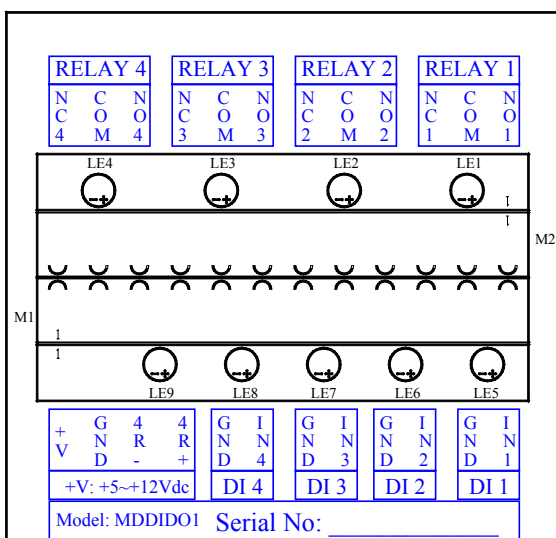

Figure 2.3.1 DI4Do4 Module Connection

Please contact factory for other DIDO Module wiring connection.

### 2.3.2 Printer Module

SY200NT Controller can connect to the following printers directly or reports printing via printer module.

1. Do-Metrics Printers
2. Inkjet Printers
3. Laser Printers

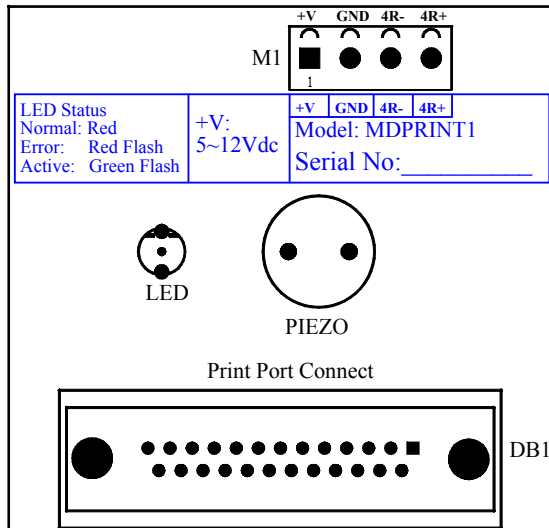

Figure 2.3.2 Connection of Printer Module

### 2.3.3 AI Module

Please contact factory for AI Module Connection.

### 3. System Setup

#### 3.1 Power up procedures

- 3.1.1 Before power up, ensure all wiring connection is correct.
- 3.1.2 When the power is turned on, the controller will automatically initialize and the LED change from Green to Red with a short Beep sound.
- 3.1.3 If the controller is ready, LCD will show Date/Time.

#### 3.2 System Setting

##### 3.2.1 Go to program mode

Follow Figure 3.2.1 to go to program mode.

Figure 3.2.1 How to Go to Program Mode

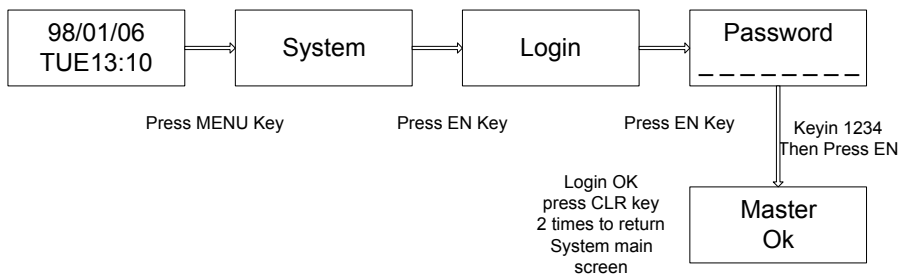

You are in program mode now.



### 3.2.2 Set Card reader ID

- a. Go to : [System] → [System Process]--[Change Reader ID]
- b. Key in Reader Serial Number and Reader ID.
- c. Repeat step b, to set all card reader ID.

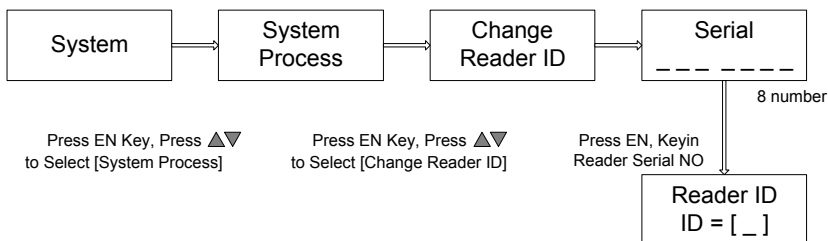

Figure 3.2.2 Set Reader ID

### 3.2.3 Set Controller ID

Controller ID Default Setting = 01.

To set other controllers ID, follow the procedures below:

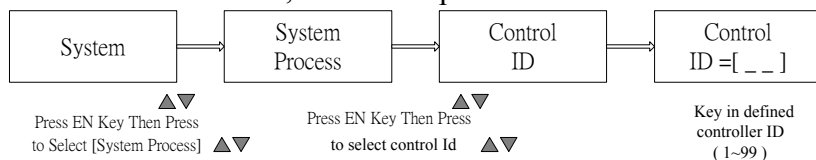
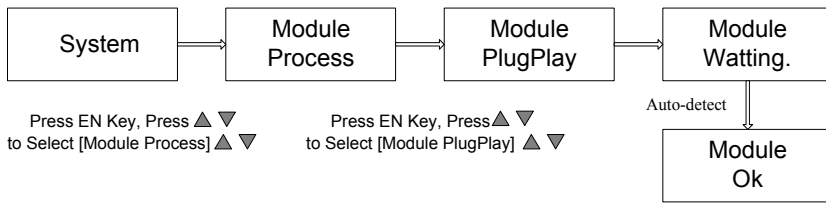

Figure 3.2.3 Set Controller ID

### 3.2.4 Get Card Reader Link to Controller

The linking of card reader to controller is not completed until the following step is done.

Figure 3.2.4 Module Plug & Play



### 3.2.5 Store Cards I Controller

Upon completion of System Setting, it is important to store all user cards in the controller. The produces is shown as below:

Figure 3.2.5 Store Cards in Controller

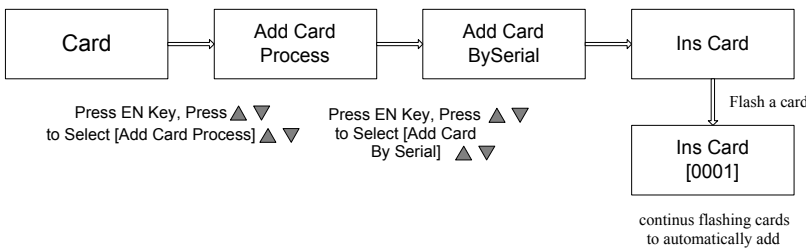

### 3.2.6 Confirmation for Systems Set Up

- a. The systems set up is completed after going through above steps 3.2.1 to 3.2.5.
- b. Press [CLR] repeatly until the LCD of controller show Date & Time.
- c. To confirm that the systems is properly set up, flash any of the cards previously stored in the controller to mak sure the "OK" LED lighted and the LCD show card serial number.

### 3.3 PCB Layout of typical SY210NT Controller

#### 3.3.1 The PCB layout of SY210NT controller

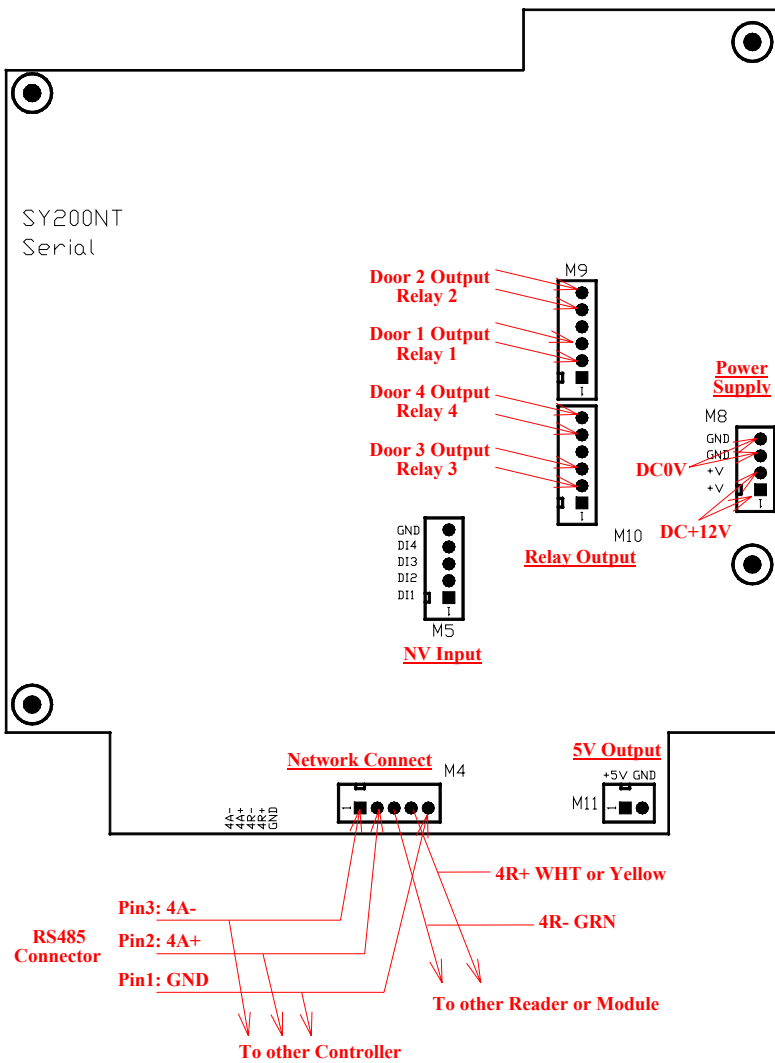

Figure 3.3.1 The PCB Layout of SY210NT Controller

3.3.2 The following setting is fixed by the systems

Card Reader ID	Controller Output
Reader ID = 1 (Door 1 Entry) or 5 (Door 1 Exit)	Relay 1
Reader ID = 2 (Door 2 Entry) or 6 (Door 2 Exit)	Relay 2
Reader ID = 3 (Door 3 Entry) or 7 (Door 3 Exit)	Relay 3
Reader ID = 4 (Door 4 Entry) or 8 (Door 4 Exit)	Relay 4

Reader ID "1" is for Door 1 Entry Reader, likewise ID "2" is for Door 2 Entry Reader, and similar to ID "3" and ID "4"

Reader ID "5", "6", "7" and "8" are for Door "1", "2", "3" and "4" Exit Reader.

## 4 Programming

### 4.1 Set Controller Date / Time

#### 4.1.1 Set Time

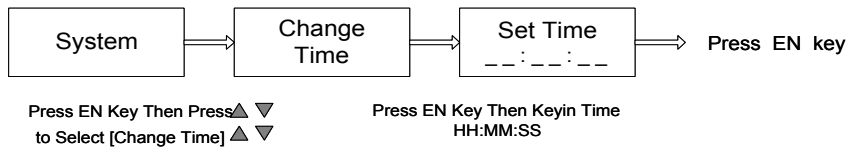

Figure 4.1.1 Set Time

#### 4.1.2 Set Date

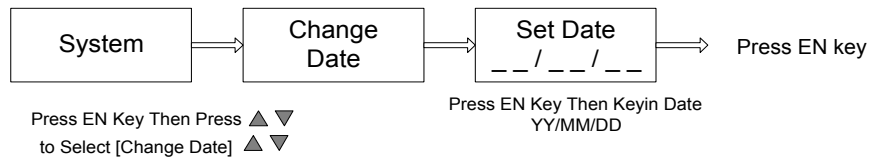

Figure 4.1.2 Set Data

## 4.2 Card Process

### 4.2.1 Store Card to Controller

- a. Logon in Controller Program Mode
- b. Store Card Procedures

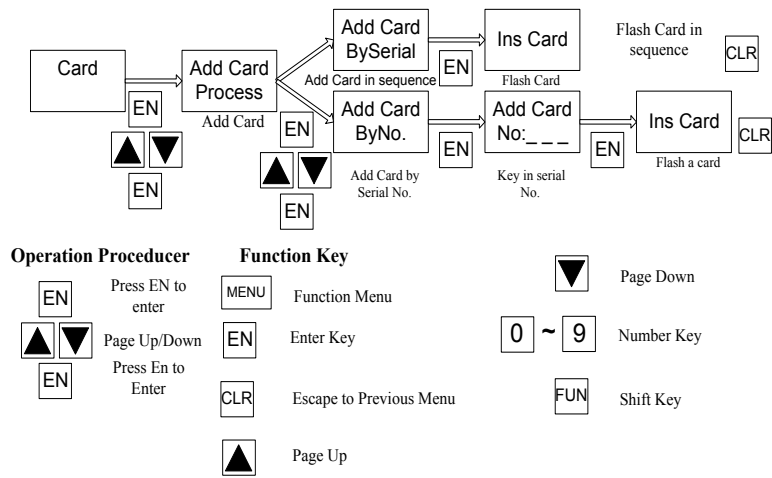

Figure 4.2.1 Store Card

## 4.2.2 Delete card from Controller

- a. Logon in Controller Program Mode
- b. Delete Card Procedures

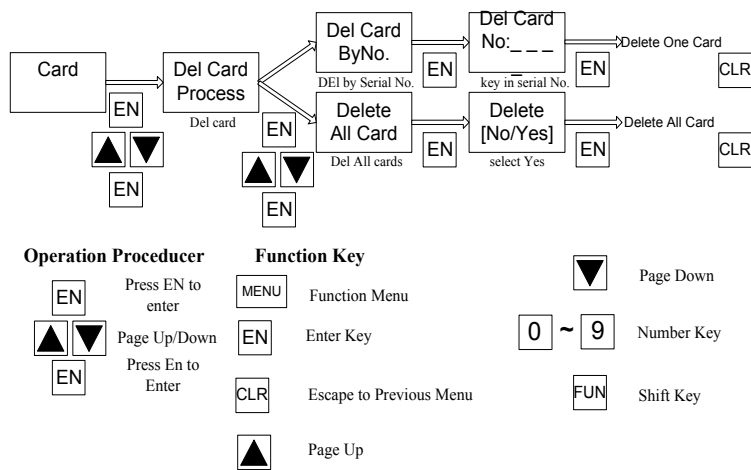
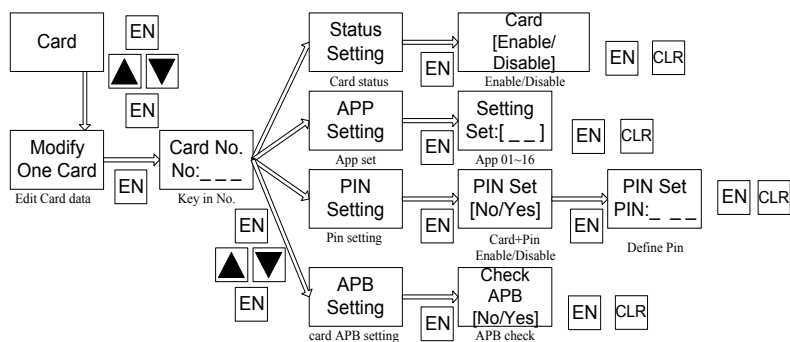

Figure 4.2.2 Delete Card

### 4.2.3 Modify Card Data

- a. Logon in Controller Program Mode
- b. Modify Card Procedure



Operation Proceuder		Function Key	
	Press EN to enter		Function Menu
	Page Up/Down		Number Key
	Press En to Enter		Escape to Previous Menu
	Page Up		Shift Key
			Page Down

Figure 4.2.3 Modify Card Data



## 4.2.4 Show Card Number

Card Code Numbers --- Fix Internal Number

Card Serial Numbers --- Depend on programming Sequence

- a. Logon in Controller Mode
- b. Show Card Number Procedures

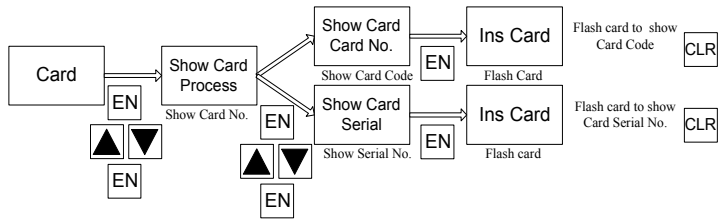

### Operation Proceducer

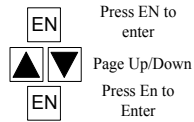

### Function Key

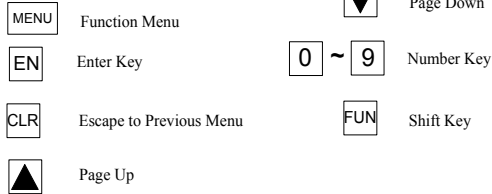

Figure 4.2.4 Show Card Number

### 4.3 Set DI Parameter

#### 4.3.1 DI Holiday Time Zone Setting

- a. Logon in Controller Program Mode
- b. Go to [Time Zone] Menu, Select [Set DI Set]
- c. Programming Produces

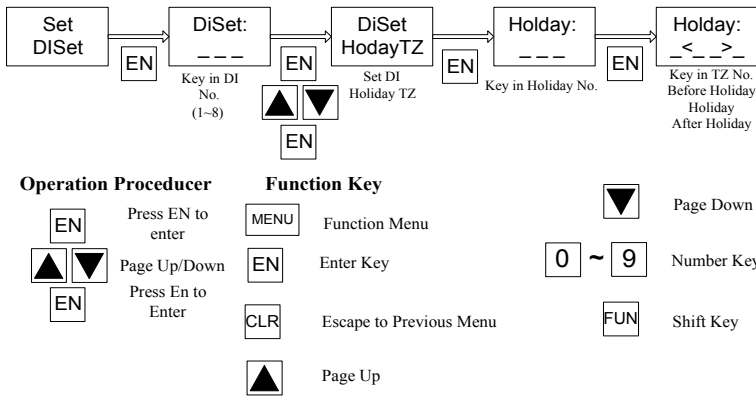

Figure 4.3.1 Set DI Holiday Time Zone

### 4.3.2 Set DI Week Time Zone

- a. Logon in Controller Program Mode
- b. Go to [Time Zone] Menu, Select [Set DI Set]
- c. Programming Produces

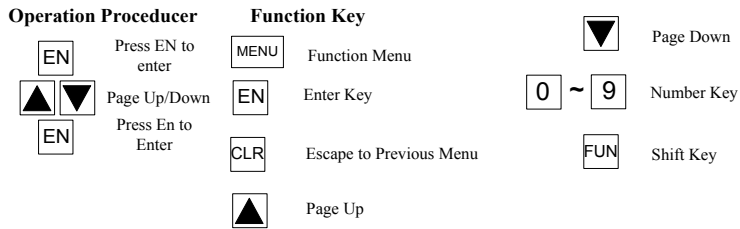
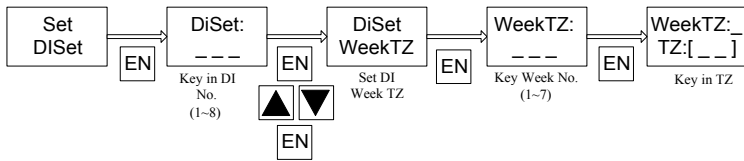

Figure 4.3.2 Set DI Week Time Zone

### 4.3.3 Set DI Action Status

- a. Logon in Controller Program Mode
- b. Go to [Time Zone] Menu, Select [Set DI Set]
- c. Programming Produces

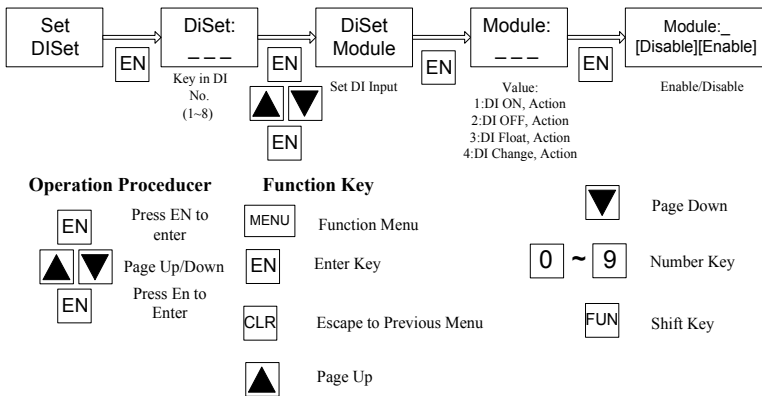

Figure 4.3.3 Set DI Action Status

## 4.4 DO Parameter Setting

### 4.4.1 Set DO Holiday Time Zone

- a. Logon in Controller Program Mode
- b. Go to [Time Zone] Menu, Select [Set DO Set]
- c. Programming Produces

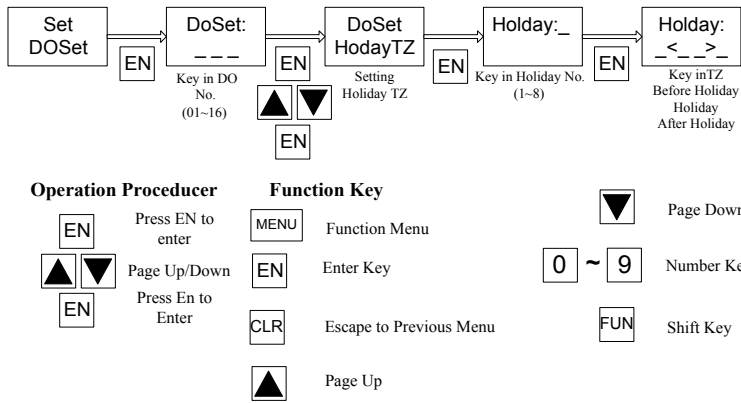

Figure 4.4.1 Set DO Holiday Time Zone

## 4.4.2 Set DO Week Time Zone

- a. Logon in Controller Program Mode
- b. Go to [Time Zone] Menu, Select [Set DO Set]
- c. Programming Produces

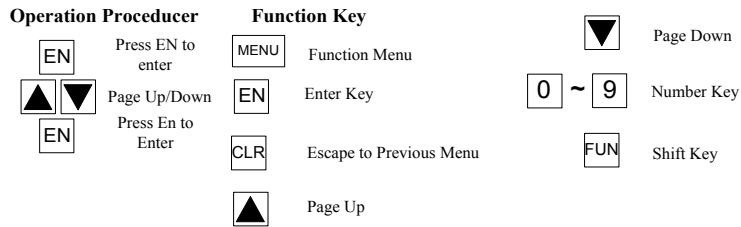
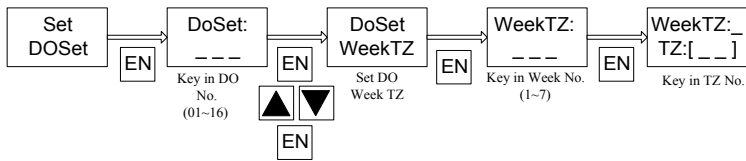

Figure 4.4.2 Set DO Week Time Zone

### 4.4.3 Set DO Action Status

- a. Logon in Controller Program Mode
- b. Go to [Time Zone] Menu, Select [Set DO Set]
- c. Programming Produces

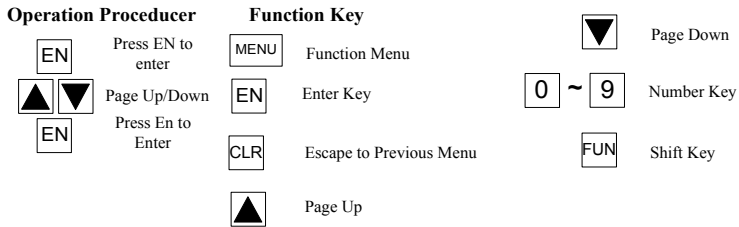
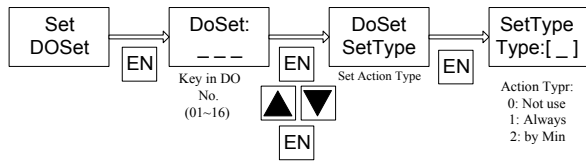

Figure 4.4.3 Set DO Action Status

## Anti-Passback Setting

### 4.4.2 Set APB for Individual Door

- a. System Provide 3-Class APB Level
- b. Programming Procedures

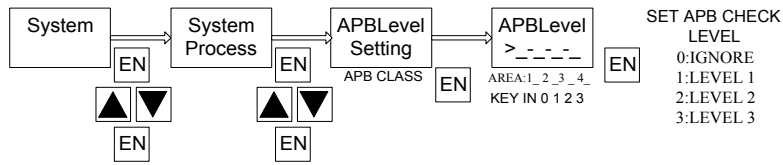
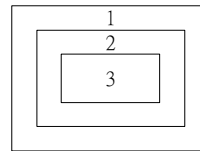

Figure 4.5.1 Anti-Passback Setting

### 4.4.3 Set APB for Individual Card

- a. Program only for those cards required APB
- b. Logon in Controller Program Mode
- c. Program Procedures

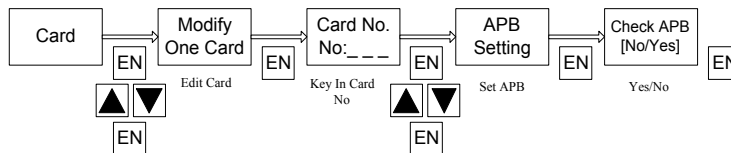

Figure 4.5.2 Set Card APB



## 4.5 Set Door Lock-Release Time

- SY200NT controller will send a signal output to release the lock (Relay 1 to 4) if a valid card is read. The setting is to determine how long you want the lock to remain open.
- Logon in Controller Program Mode.
- Program Procedures

Figure 4.6 Set Door Lock-Release Time

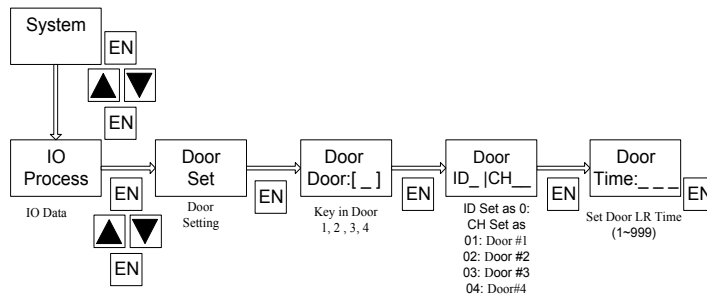

## 4.6 Set Timer, TimeZone, Holiday TimeZone

### 4.6.1 Set Timer

- A Total of 30 Timers may be programmed. The Timers are used in other commands to set time zone
- Logon in Controller Program Mode
- Programming Procedures

Figure 4.7.1 Set Timer

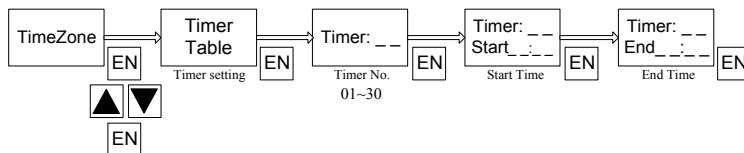

#### 4.6.2 Set TimeZone

- A Total of 60 TimeZone may be programmed. Each with 3 sets of timers
- TimeZone is important and used in access control and DIDO programming etc
- Logon in Controller Program Mode
- Programming Procedures

Figure 4.7.2 Set TimeZone

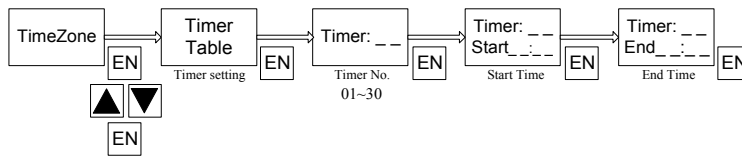

#### 4.6.3 Set Holiday TimeZone

- Holiday access control include : Holiday Eve, Holiday and day after Holiday
- To define Holiday Access Control, must go to TimeZone] Menu, select [APPSET] to set [Holiday TimeZone] first
- A total of 8 Holiday TimeZone may be set
- Programming procedures

Figure 4.7.3 Set Holiday TimeZone

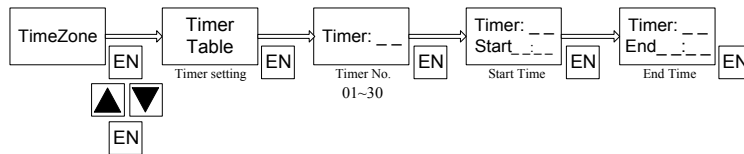

## 4.7 Set Application Set [APPSET]

### APPSET Setting List

- a. Edit Holiday TimeZone
- b. Edit Weekly TimeZone
- c. Set Out Flag (Exit control)
- d. Set Door Flag (Door Access Control)
- e. Set Security PIN Code (Common PIN)
- f. Set Personal PIN Code (APP Group PIN)

### APP Set Flow Chart

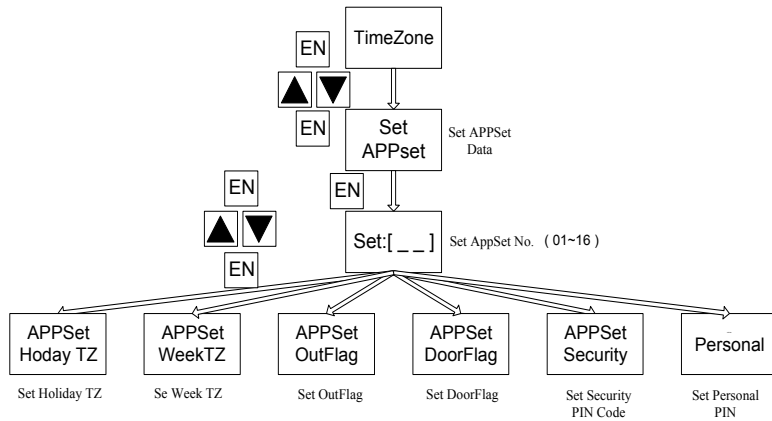
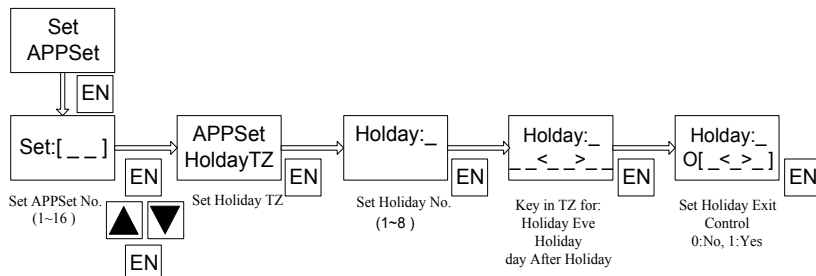

Figure 4.8 APP set Flow Chart

### 4.7.1 Set Holiday TimeZone

- The Controller Provides 8 Group of Holiday TimeZone, Date include Holiday Eve, Holiday and day after Holiday
- Logon in Controller Program Mode
- Programming Procedures

Figure 4.8.1 Set Holiday TimeZone



### 4.7.2 Set Weekly TimeZone

- To set Daily TimeZone and within a week
- Logon in Controller Program Mode
- Programming Produces

Figure 4.8.2 Set Weekly TimeZone

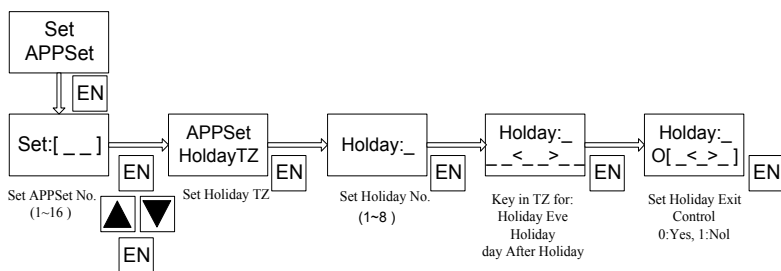

### 4.7.3 Set Out Flag

- The function is used to set the Exit Control for individual door
- Logon in Controller Program Mode
- Programming Procedures

Figure 4.8.3 Set Out Flag

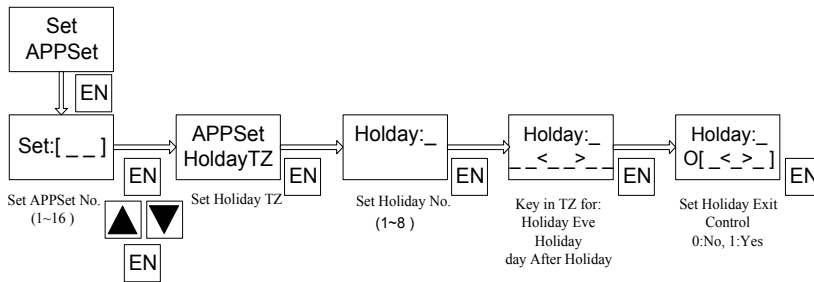

### 4.7.4 Set Door Flag

- The function may be used to set the access level
- Logon in Controller Program Mode
- Programming Procedures

Figure 4.8.4 Set Door Flag

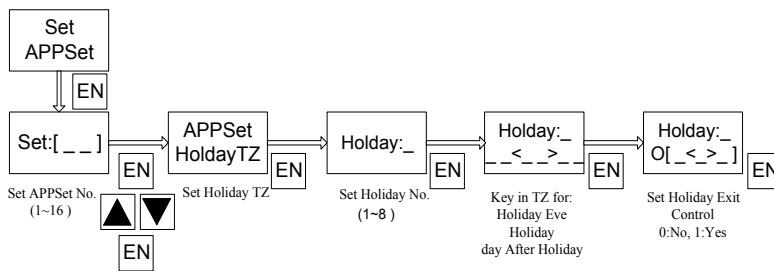

#### 4.7.5 Set Security PIN Code

- The function may be used to set Card + PIN (Common PIN)
- Logon in Controller Program Mode
- Programming Procedures

Figure 4.8.5 Set Security PIN Code

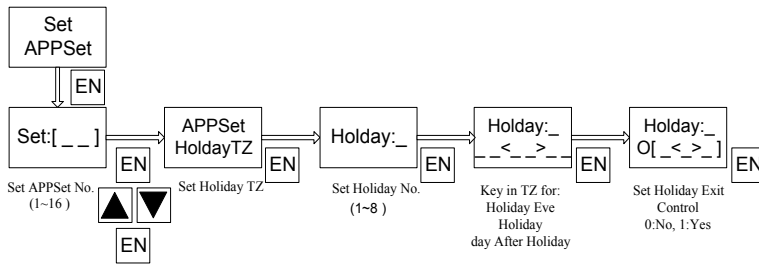

#### 4.7.6 Set Personal PIN Code

- The function may be used to set Card + PIN (Personal PIN)
- Logon in Controller Program Mode
- Programming Procedures

Figure 4.8.6 Set Personal PIN Code

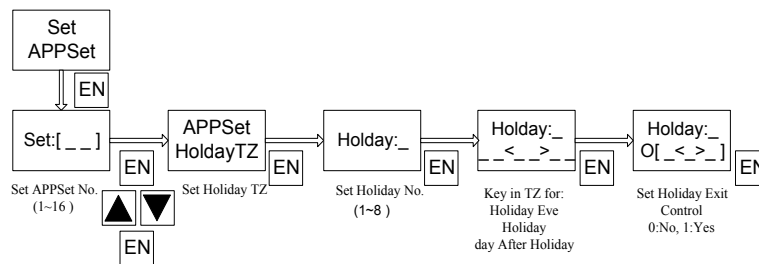

## Set Flow Process

SY200NT Controller Provide:

A Total of 26 Events for detection

A Total of 11 Actions for Execute

SY200NT will work depending on following sequence:

Source (Detecting Events)

Target (Action)

Mode (Action Mode)

## Event Table

Item	Event Function	Description		Delay Time
		ID (0-9)	Channel (0 -60)	
1	Card Sense	1-8 : Reader ID 9 : All Module	None	None
2	In Check OK	Same as above	None	None
3	Out Check OK	Same as above	None	None
4	Invalid Card	Same as above	None	None
5	Disable Card	Same as above	None	None
6	Invalid TimeZone	Same as above	None	None
7	Invalid Door	Same as above	None	None
8	Invalid PIN	Same as above	None	None
9	Invalid PIN Three Time	Same as above	None	None
10	ReEntry	Same as above	None	None
11	ReExit	Same as above	None	None
12	KeyPad Press	1-8 : KEYPAD 9 : SY200NT	1-10 :1-9,0 11-20 : F1-F9,F0	None
13	DI On	1-8 : MDDIDO 9 : SY200NT	1-16 DI Point	0-99 Seconds
14	DI Off	1-8 : MDDIDO	1-16 DI Point	0-99 Seconds

		9 : SY200NT		
15	DI Float	1-8 : MDDIDO 9 : SY200NT	1-16 DI Point	0-99 Seconds
16	DI Change Status	1-8 : MDDIDO 9 : SY200NT	1-16 DI Point	None
17	DI Set On	1-4 DI Point	1-4 TimeZone Number	None
18	DI Set Off	1-4 DI Point	1-4 TimeZone Number	None
19	DI Set Float	1-4 DI Point	1-4 TimeZone Number	None
20	DI Set Change	1-4 DI Point	1-4 TimeZone Number	None
21	DO Set On	None	1-60 TimeZone Number	None
22	DO Set Off	None	1-60 TimeZone Number	None
23	Time Out	None	1-60 TimeZone Number	0-99 Seconds
24	Forced	None	1-60 TimeZone Number	0-99 Seconds
25	Duress	None	1-60 TimeZone Number	None
26	HardWare Error	None	Module No = 1-20 59 . SY200NT 60 . ALL	None

### Action Table

Item	Event Function	Description			
		ID(0-9)	Channel(0-60)	Method(0-4)	
1	SY200NT	LED Code 1 : Ok LED 2 : Error Led 3 : Set up LED 4 : Active LED 5 : BlackLight LED	LED Color 1 : Dark (Blacklight Off) 2 : Red ((Blacklight On) 3 : Green 4 : Orange	1 : always 2 : 100ms 3 : sec 4 : min	Time (1-999)
2	Set Sound	Sound Code 1 : Beep sound 2 : Do Sound		1 : always 2 : 100ms 3 : sec 4 : min	Time (1-999)
3	Set Alarm Sound	Alarm Code 1 : Steal 2 : Emergency 3 : Fire Alarm 4 : Gas 5 : Error 6 : Duress		1 : always 2 : 100ms 3 : sec 4 : min	Time (1-999)
4	Set	DO Action	DO Point 1-4 :	1 : always	Time



	System Internal DO	1 : Open 2 : Close 3 : Change	Door 1-4	2 : 100ms 3 : sec 4 : min	(1-999)
5	Set DIDO Module DO Point On	DIDO Module ID 1-8	DO Point 1-16	1 : always 2 : 100ms 3 : sec 4 : min	Time (1-999)
6	Set DIDO Module DO Point OFF	DIDO Module ID 1-8	DO Point 1-16	1 : always 2 : 100ms 3 : sec 4 : min	Time (1-999)
7	SET DIDO Module DO Point Change	DIDO Module ID 1-8	DO Point 1-16	1 : always 2 : 100ms 3 : sec 4 : min	Time (1-999)
8	Show Message	1-8 : KeyPad Module ID 9 : Sy200NT	PostMessage Code 1-16	1 : always 2 : 100ms 3 : sec 4 : min	Time (1-999)
9	Show Data	1-8 : KeyPad Module ID 9 : Sy200NT	Show Data Code 1-13 See Data Code Table	1 : always 2 : 100ms 3 : sec 4 : min	Time (1-999)
10	Check Card	Event : Invalid Card Disable Card Invalid Door Invalid TimeZone Invalid PIN Invalid PIN Three Time ReEntry ReExit In Check Ok Out Check Ok			If the Card + PIN is required by user or system. The event will appear after entering Password.
11	Add InOut	See Event Name			

## Default Flow Control Setting

No	Event	IDEvent	Chanel Event	Action	IDAction	Chanel Action	Method	Time
1	Card Sense	All Module		Check Card				
2	In Check Ok	All Module		LED	Ok LED	Green	Second	2
3	In Check Ok	All Module		Sound	Beep			
4	In Check Ok	All Module		Show Data	SY200	Card Find No	Second	2
5	In Check Ok	All Module		Add InOut				
6	Out Check Ok	All Module		LED	Ok LED	Green	Second	2
7	Out Check Ok	All Module		Sound	Beep			
8	Out Check Ok	All Module		Show Data	SY200	Card Find No	Second	2
9	Out Check Ok	All Module		Add InOut				
10	Invalid Card	All Module		LED	Error LED	Red	Second	2
11	Invalid Card	All Module		Sound	Bell			
12	Invalid Card	All Module		Show Data	SY200	Invalid Card	Second	2
13	Invalid Card	All Module		Add InOut				
14	Disable Card	All Module		LED	Error LED	Red	Second	2
15	Disable Card	All Module		Sound	Bell			
16	Disable Card	All Module		Show Data	SY200	Disable Card	Second	2
17	Disable Card	All Module		Add InOut				
18	Invalid TimeZone	All Module		LED	Error LED	Red	Second	2
19	Invalid TimeZone	All Module		Sound	Bell			
20	Invalid TimeZone	All Module		Show Data	SY200	Invalid TimeZone	Second	2
21	Invalid TimeZone	All Module		Add InOut				
22	Invalid Door	All Module		LED	Error LED	Red(2)	Second	2
23	Invalid Door	All Module		Sound	Bell			
24	Invalid Door	All Module		Show Data	SY200	Invalid Door (5)	Second	2
25	Invalid Door	All Module		Add InOut				
26	Invalid ReEntry	All Module		LED	Error LED	Red(2)	Second	2
27	Invalid ReEntry	All Module		Sound	Bell			
28	Invalid ReEntry	All Module		Show Data	SY200	Invalid ReEntry (8)	Second	2
29	Invalid ReEntry	All Module		Add InOut				
30	Invalid ReExit	All Module		LED	Error LED	Red	Second	2
31	Invalid ReExit	All Module		Sound	Bell			
32	Invalid ReExit	All Module		Show Data	SY200	Invalid ReExit	Second	2
33	Invalid ReExit	All Module		Add InOut				
34	Card Sense	All Module		LED	Active LED	Red	Second	2
35								
36								

## Flow Control Instruction

Following is an example of flow control after it senses a card.

No	Event	IDEvent	Chanel Event	Action	IDAction	Chanel Action	Method	Time
----	-------	---------	--------------	--------	----------	---------------	--------	------

1	Card Sense	All Module		Check Card				
2	In Check Ok	All Module		LED	Ok LED	Green	Second	2
3	In Check Ok	All Module		Sound	Beep			
4	In Check Ok	All Module		Show Data	SY200	Card Find No	Second	2
5	In Check Ok	All Module		Add InOut				

- No. 1 Ask all module (reader) of controller to read card and ask controller to check card status.
- No. 2 When In Check OK, (reader ID=1, entry reader) the OK LED of controller will changes to green color and active for 2 seconds.
- No. 3 When In Check OK, controller will create a Beep sound.
- No. 4 When In Check OK, the controller LCD will show card serial number and it will active for 2 seconds.
- No. 5 When in Check OK, controller will add a record to InOut transaction data base.

When the controller is "In Check OK" (Valid Card), it will active the output relay where the card is read.

Following is a example of flow control using DI Point for exit button.

No	Event	IDEvent	ChanelEvent	Action	IDAction	ChanelAction	Method	Time
37	DI On	9	1	SY200 DO	Open	1	3	3

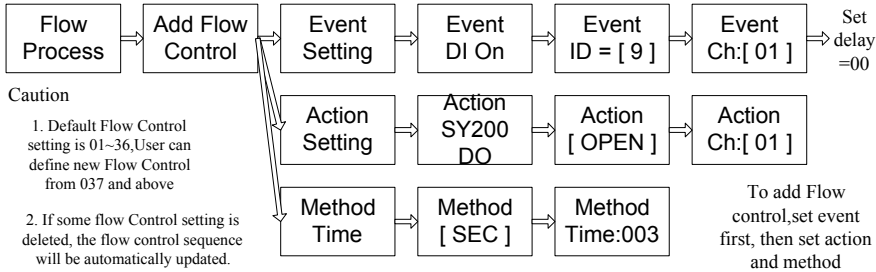

As above setting table:

- Event = DI On : Ask controller active when DI Point is On.
- Event ID = 9 : the DI Point come from SY200NT internal DI.
- Chanel Event = 1 : DI Point is the first one.
- Action = SY200 DO : setting SY200 DO is for action point.
- IDAction = Open : set action is open.
- ChanelAction = 1 : output is come from DO1
- Method = 3 : active time is in second
- Time = 3 : output active 3 seconds

Program Procedures for above

## 4.10 Flowchart

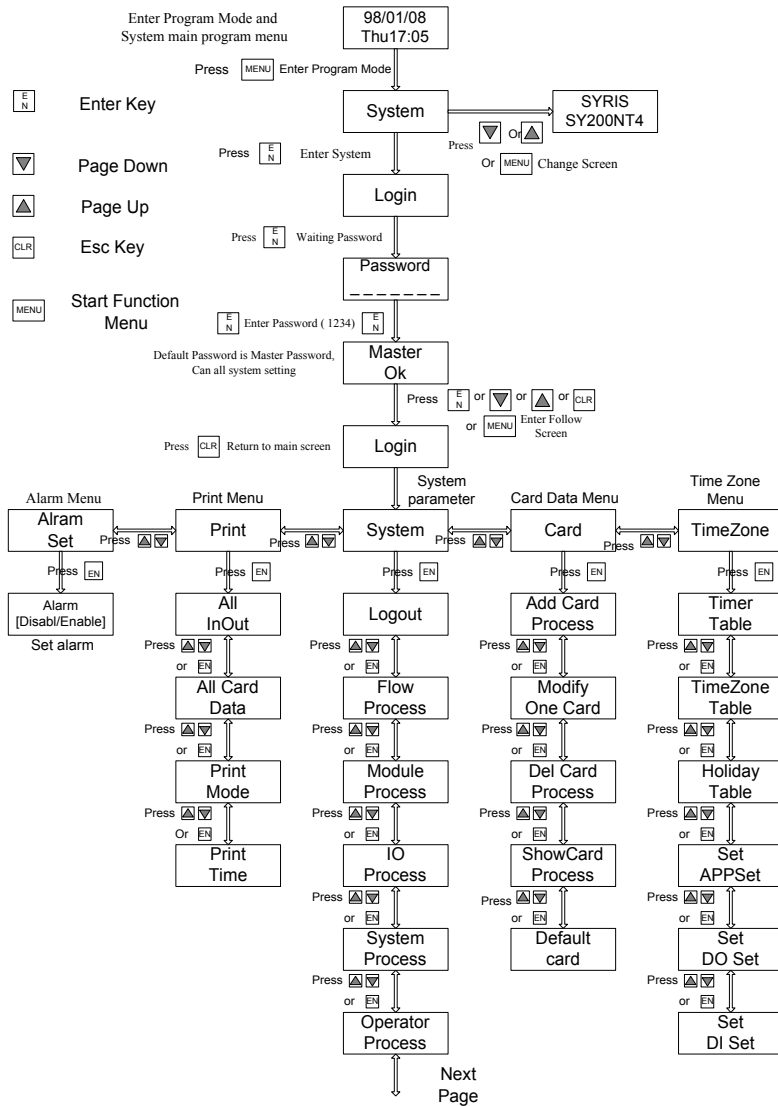

Flowchart continue

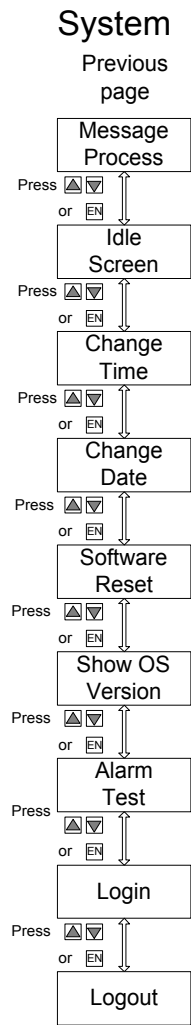

## 4.11 Typical Wiring Connection

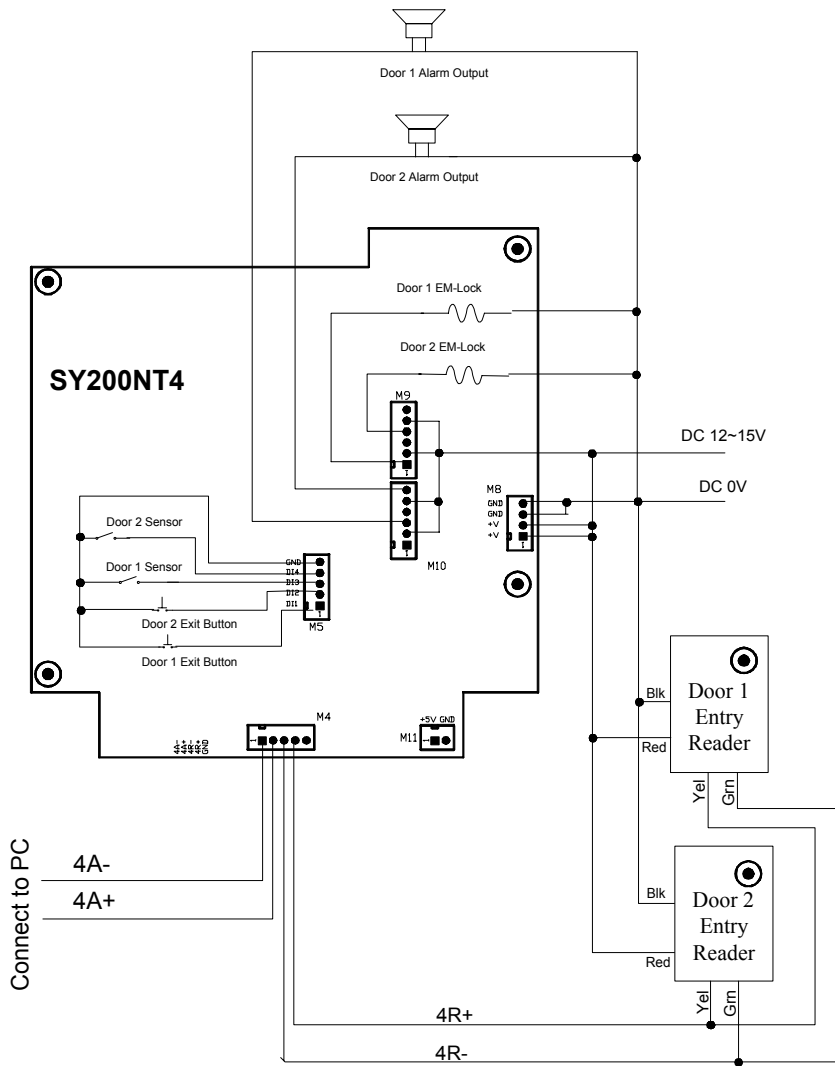

## 5 Technical Information

### 5.1 SY210NT Controller Specification

#### SY210NT Controller Specification

Items / Spec	SY210NT2	SY210NT4
Number of Cards	9,999	9,999
Number of Readers	4 (2In,2Out)	8 (8In,8Out)
Door Control	4	4
Reader Technologies	SYRIS RS485 format	SYRIS RS485 format
User P.I.N. code	4 digital code	4 digital code
Input Points	Normally 4, Expandable to 64	Normally 4, Expandable to 64
Control relay Output	Normally 2, Expandable to 64	Normally 4, Expandable to 64
Communication ports	RS485, 2 Ports	RS485, 2 Ports
Baud rate	19,200 bauds	19,200 bauds
Programmable time zone	60 time zone	60 time zone
Group (application set)	16	16
Holidays	366	366
Controller ID	01-99	01-99
Expand modules	SYRIS NT Serial Module	SYRIS NT Serial Module
Anti-passback	Up to 3 level of local and / or group anti-passback	Up to 3 level of local and / or group anti-passback
Keypad input	16 key keypad	16 key keypad
Keypad backlight	Built-in	Built-in
LCD display	8 x 2 LCD with backlight	8 x 2 LCD with backlight
Speaker output	Maximun 0.2 W	Maximun 0.2 W
Indicator	5 LED	5 LED
Operating temperature	2 °C to 55 °C	2 °C to 55 °C
Storage temperature	-25 °C to 85 °C	-25 °C to 85 °C
Power supply input	DC 11V to 20V	DC 11V to 20V
Power consumption	1W to 10W	1W to 10W
Dimensions (mm)	107W x 150H x 27D	107W x 150H x 27D

### 5.2 SYW95A Access Control Software

- Link up to 99 Controllers, 396 doors, 792 Readers
- 3 level of anti-passback
- User define language
- 6000 card holders



### 5.3 SYRIS Proximity Reader

#### SYRIS Proximity Reader Specification

- ◆ Water resistant, high security, high durability, and low identification error rate.
- ◆ Can be mounted directly on metal without affecting its reading performance.
- ◆ SYRIS proximity reader is able to interface with all existing access control system by Wiegand™ formats, RS485 formats or etc.

Items / Spec	SYRDS1-485 (SYRDSSS1)	SYRDS1-W26 (SYRDSSW1)
Frequency	125KHz	125KHz
Card (Transponder)	SYRIS card	SYRIS card
Reader range*	5cm ~ 15cm	5cm ~ 15cm
Card read time	0.1sec (typical)	0.1sec (typical)
Output interface	SYRIS RS485 formats	SYRIS RS485 formats
Color	Beige or dark-grey	Beige or dark-grey
Operating temperature	2 °C to 55 °C	2 °C to 55 °C
Storage temperature	-25 °C to 85 °C	-25 °C to 85 °C
Power supply input	5V ~ 15Vdc	5V ~ 15Vdc
Dimensions (mm)	75W x 115H x 15D	75W x 115H x 15D

Items / Spec	SYRDL1-485 (SYRLSSS1)	SYRDL1-W26 (SYRLSSW1)
Frequency	125KHz	125KHz
Card (Transponder)	SYRIS card	SYRIS card
Reader range*	4cm ~ 12cm	4cm ~ 12cm
Card read time	0.1sec (typical)	0.1sec (typical)
Output interface	SYRIS RS485 formats	SYRIS RS485 formats
Color	Beige or dark-grey	Beige or dark-grey
Operating temperature	2 °C to 55 °C	2 °C to 55 °C
Storage temperature	-25 °C to 85 °C	-25 °C to 85 °C
Power supply input	5V ~ 15Vdc	5V ~ 15Vdc
Dimensions (mm)	41W x 140H x 20D	41W x 140H x 20D

\*The specification is preliminary and is subject to change without prior notice.

Note: \*Reading range is subject to card type, site interference and antenna specs for more information.

### 5.4 Proximity Card (Transponder)

#### Card (transponder) Specification

- ◆ No battery needed for all card (transponder)
- ◆ SYRIS proximity reader recognizes over 4 billion unique codes

Items / Specs	Thick card	ISO card	Key chain	Key chain
Model number	SY-Prox-1	SY-ISO-1	SY-Key-1	SY-Key-2
Read range	5cm~15cm	5cm~15cm	2cm~8cm	2cm~8cm
Dimensions(mm)	86*55*1.9	86*54*0.76	24.5*33.5*4.7	17*45*8.2
Color	White/Dark-grey	White	Beige/Dark-grey	Beige/Dark-grey

## 5.5 Power Consumption (DC12V)

Items / Spec	Power consumption per unit
Controller	400ma
Card reader	100ma
Printer Module	100ma
DIDO Module	250ma