

# Soil Pulverizer

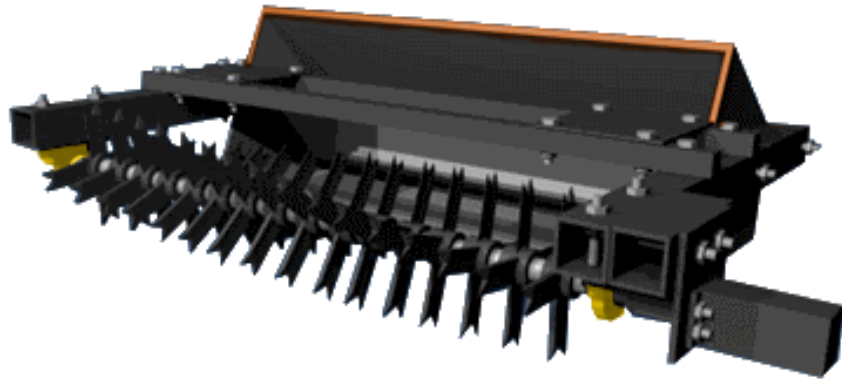

Complete Fabrication Instructions, 2011  
Open Source Ecology

# Introduction

The purpose of this guide is to provide all information to make the 2011 version Soil Pulverizer from stock steel and parts. More information and a constantly updated procedure can be found on the OSE wiki [Soil Pulverizer Manufacturing Page](#).

This guide is broken into 2 main fabrication steps: Parts Fabrication, and Parts Assembly. After these two have been completed, the machine can be painted. After it's painted, the remaining hydraulics must be installed. After that, it should be ready to go! See the [User Manual](#) for how to adjust the height of the tines to your soil cutting needs.

Parts fabrication begins with the cutting of all stock steel as listed in the cut list. It focuses on cutting, drilling, punching, bolting and welding the steel into parts pieces and then assembling the parts pieces into individual parts. Each part (IE Bucket, Arm Rest...) listed in this section is independent of all others, therefore the parts can be fabricated in any order.

Parts assembly joins all of the parts into the whole machine. It mostly involves bolting, but some parts must still be welded upon assembly.

## Table of Contents

Introduction.....	2
Bill of Materials.....	5
Steel.....	5
Hardware.....	5
Hydraulics.....	6
Cut List.....	7
Parts Fabrication - Bucket.....	8
Piece Parts Preparation.....	8
Large Tube.....	8
Triangle Plates.....	9
Side Brace Plates.....	9
Bottom Mounting Plates.....	10
Piece Parts Assembly.....	10
Side Plates.....	10
Back Plate.....	10
Bottom Plate.....	11
Cross Supports.....	11
Parts Assembly.....	12
1. Weld Bucket Plates.....	12
2. Weld Cross Supports.....	12
3. Weld Rear Mounting Plate.....	12
Parts Fabrication - Frame Pivot Hinge.....	13
Procedure.....	13
Joint Plate.....	13
Large Tube.....	13
Parts Fabrication - Arm Rest.....	15
Parts Fabrication - Shaft and Motor Frame.....	16
Parts Preparation.....	16
Motor Plate.....	16
Bearing Plate.....	16
Cross Tube.....	17
Parts Assembly.....	17
Tines.....	18

---

Parts Fabrication - Coupler .....	20
Parts Fabrication - Additional Piece Parts.....	22
Small Tube .....	22
Motor Mount Plate.....	22
Hinge Rod .....	22
Hinge Pin.....	23
Assembly- Front Frame.....	24
Assembly- Bend the Tines.....	26
Assembly- Install the Shaft and Motor .....	27
Assembly – Install the Top Plate.....	29
Assembly- Paint .....	30
Assembly – Hydraulics .....	31
Prepare the hoses.....	31
Assemble motor hydraulics .....	31

# Bill of Materials

## Steel

Type	Stock Size (Inches)	Length (inches)
Sheet	0.125 X 48	40
Plate	0.25 X 16	29
	0.25 X 24	48
	0.25 x 16	48
<a href="#">Beveled Flat</a>	0.5 X 6	49
Flat	0.25 X 2	5.5
	0.25 X 2.5	48.5
	0.25 X 5.5	48.5
	0.375 X 3	324
	0.5 X 2	16.5
	0.5 X 3	39
	0.5 X 4	12
	0.5 X 6	8
	0.5 X 8	36
	0.75 X 2	6
	0.75 X 4	35.75
Pipe	<a href="#">2" SCH 80 Pipe</a>	44.5
	2" SCH 40 Pipe	1
Round Tubing	<a href="#">0.5ID X 0.75OD</a>	16
	0.5	58
Square Tubing	1.875	52
	0.1875 X 2.5X2.5	36
	0.25 X 2X2	75
	0.25 X 2X4	56

## Hardware

Type	Size (Inches)	QTY
Nut, Hex	0.375"-16	1
Nut, Hex	0.5"-13	2
Nut, Hex	0.5625-11	8
Nut, Hex, Steel	0.75"x10	18
Nut, Hex, Galv.	0.75"x10	4
Nut, Nylon Lock	1"-8	2
Bolt, Hex	0.3750-16x3x3	1
Bolt, Hex	0.5000-13x2.5x2.5	2
Bolt, Hex	0.5625-11x2x2	8
Bolt, Hex	0.7500-10x1.25x1.25	14
Bolt, Hex	0.75"-10x1.5"x1.5"	4
Bolt, Hex	0.75"-10x2"x2"	2
Bolt, Hex	0.75"-10x5.5"x1.75"	2
Bolt, Hex	1.0"-8x3"x2.25"	2
Washer, Wide	0.5625"	8
Washer, Wide	0.5"	2
Washer, Wide	0.75"	6
Washer, Wide	1.0"	4
Misc.	<a href="#">COUPLER, 1-3/8" 6T SPLINED</a>	1
Misc.	<a href="#">BEARING WITH LOCK COLLAR, FS210, 1-7/8"</a>	2
Misc.	COTTER PIN, 1/8" X 2 1/2"	6

## *Hydraulics*

Description	Quantity	Source
Hydraulic Motor	1	<a href="https://www.surpluscenter.com/item.asp?item=9-7368-125&amp;catname=hydraulic">https://www.surpluscenter.com/item.asp?item=9-7368-125&amp;catname=hydraulic</a>
SAE 10 to 1/2 NPT swivel	2	<a href="https://www.surpluscenter.com/item.asp?item=9-6900-10-8&amp;catname=hydraulic">https://www.surpluscenter.com/item.asp?item=9-6900-10-8&amp;catname=hydraulic</a>
SAE 4 to 1/4 NPT swivel	1	<a href="https://www.surpluscenter.com/item.asp?item=9-6900-4-4&amp;catname=hydraulic">https://www.surpluscenter.com/item.asp?item=9-6900-4-4&amp;catname=hydraulic</a>
1/2 NPTM x 12' Hose	2	<a href="https://www.surpluscenter.com/item.asp?item=905-12144&amp;catname=hydraulic">https://www.surpluscenter.com/item.asp?item=905-12144&amp;catname=hydraulic</a>
1/4 NPTM x 12' Hose	1	<a href="https://www.surpluscenter.com/item.asp?item=916-14144&amp;catname=hydraulic">https://www.surpluscenter.com/item.asp?item=916-14144&amp;catname=hydraulic</a>
30 gpm Quick Coupler set, Body Size: 1/2, Thread Size: 3/4-14 NPT	3	Dalton Hydraulics
1/4" Quick Coupler Set	1	<a href="https://www.surpluscenter.com/item.asp?item=9-6314&amp;catname=hydraulic">https://www.surpluscenter.com/item.asp?item=9-6314&amp;catname=hydraulic</a>
1/4" Male Quick Coupler	1	<a href="https://www.surpluscenter.com/item.asp?item=9-5924&amp;catname=hydraulic">https://www.surpluscenter.com/item.asp?item=9-5924&amp;catname=hydraulic</a>

## Cut List

Type	Stock Size (Inches)	Length (inches)	QTY	Primary Part Name	Secondary Part Name
Sheet	0.125 X 48	40	1	PIECE PARTS	TOP PLATE
Plate	0.25 X 16	29	1	BUCKET	SIDE PLATES
	0.25 X 24	48	1	BUCKET	BOTTOM PLATE
	0.25 x 16	48	1	BUCKET	BACK PLATE
<u>Beveled Flat</u>	0.5 X 6	49	1	BUCKET	BLADE
Flat	0.25 X 2	5.5	1	BUCKET	TRIANGLE PLATE
	0.25 X 2.5	48.5	1	BUCKET	CROSS SUPPORT PLATE
	0.25 X 5.5	48.5	1	BUCKET	CROSS SUPPORT PLATE LOWER
	0.375 X 3	48	1	BUCKET	REAR MOUNTING PLATE
	0.375 X 3	11.5	24	TINE	TINE
	0.5 X 2	4.25	2	FRONT FRAME	END PLATE, CROSS TUBE
	0.5 X 2	4	2	ARM REST	PLATE, ARM REST
	0.5 X 3	19.5	2	BUCKET	SKID PLATE
	0.5 X 4	6	2	BUCKET	BOTTOM MOUNTING PLATES
	0.5 X 6	8	1	PIECE PARTS	PLATE, MOTOR MOUNT
	0.5 X 8	12	1	FRONT FRAME	PLATE, MOTOR END
	0.5 X 8	12	2	FRONT FRAME	PLATE, BEARING
	0.75 X 2	3	2	BUCKET	HARD STOP PLATE
	0.75 X 4	23.75	1	BUCKET	SIDE BRACE PLATE
	0.75 X 4	6	2	PIVOT	JOINT PLATE
Pipe	2" SCH 80	2.5	1	COUPLER	COUPLER, SHAFT SIDE
	2" SCH 80	3.5	12	TINE	TUBE, TINE
	2" SCH 40	1	1	COUPLER	SLEEVE
Round Tubing	0.5ID X 0.75OD	2	8	PIECE PARTS	HINGE PIPE
Round	0.5	50	1	PIECE PARTS	ROD, HINGE
	0.5	4	2	PIECE PARTS	ROD, PIN
	1.875	52	1	PIECE PARTS	SHAFT
Square Tubing	0.1875 X 2.5X2.5	6	2	BUCKET	LARGE TUBE, ANGLED
	0.1875 X 2.5X2.5	12	2	PIVOT	LARGE TUBE
	0.25 X 2X2	24	2	PIECE PARTS	SMALL TUBE
	0.25 X 2X2	13.5	2	ARM REST	SMALL TUBE, ARM
	0.25 X 2X4	56	1	FRONT FRAME	CROSS TUBE

## Parts Fabrication - Bucket

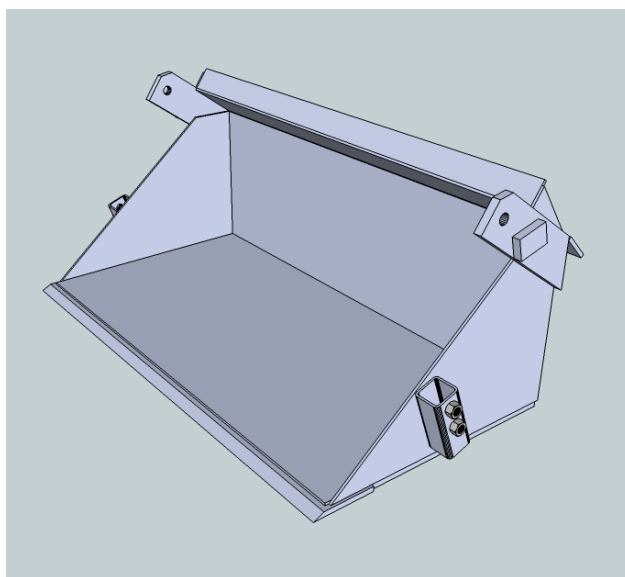

[Sketchup Model](#)

### Tools:

- Torch
- Welder
- Angle Grinder
- Hole Puncher
- Protractor

### Materials:

- 3/4" Nuts, Steel (4)

Type	Size	Length	Qty.	Part
Beveled Flat	0.5 X 6	49	1	BLADE
Flat	0.25 X 2	5.5	1	TRIANGLE PLATE
Flat	0.25 X 2.5	48.5	1	CROSS SUPPORT PLATE
Flat	0.25 X 5.5	48.5	1	CROSS SUPPORT PLATE LOWER
Flat	0.25 x 16	48	1	BACK PLATE
Flat	0.375 X 3	48	1	REAR MOUNTING PLATE
Flat	0.5 X 3	19.5	2	SKID PLATE
Flat	0.5 X 4	6	2	BOTTOM MOUNTING PLATES
Flat	0.75 X 2	3	2	HARD STOP PLATE
Flat	0.75 X 4	23.75	1	SIDE BRACE PLATE
Plate	0.25 X 16	29	1	SIDE PLATES
Plate	0.25 X 24	48	1	BOTTOM PLATE
Square Tubing	0.1875 X 2.5X2.5	6	2	LARGE TUBE

## Piece Parts Preparation

### Large Tube

You need to make 2 of these.

1. Torch the holes as shown. Make sure they are large enough for a 3/4" bolt.
2. Grind away the slag.
3. Weld the 3/4" nuts 100% over the holes, insuring the nut is level and the hole is clear.
  - Cover the top of the nut so no spatter goes inside while welding.

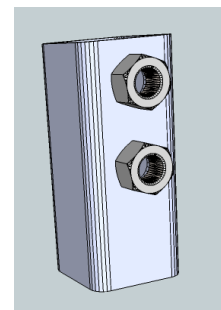
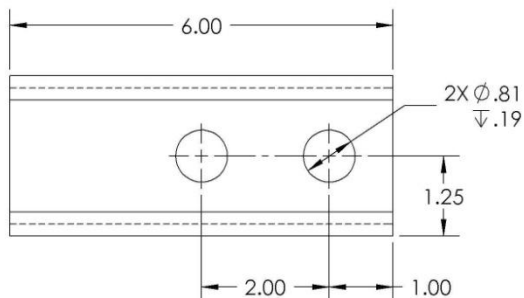



**Triangle Plates**

- Torch or shear the flatbar into two pieces as shown.

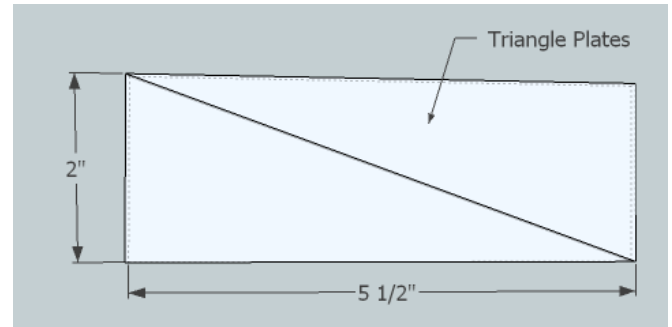

**Side Brace Plates**

You need 2 of these which are mirror images of each other.

1. Torch or shear the flatbar into two pieces as shown.

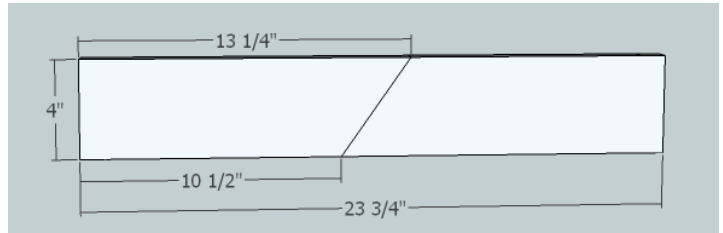

2. Punch the hole as shown.
3. Torch away the corner as shown.

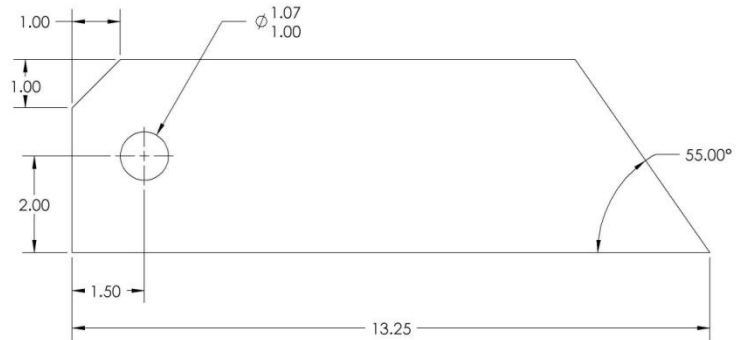

4. Weld the Hard Stop Plate to them as shown.

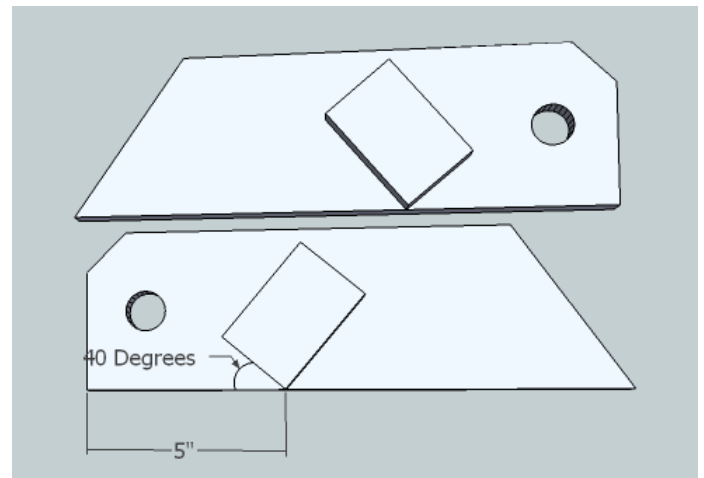

**Bottom Mounting Plates**

You need to make 2 of these.

1. Punch the hole as shown.
2. Torch or shear away the corner as shown.

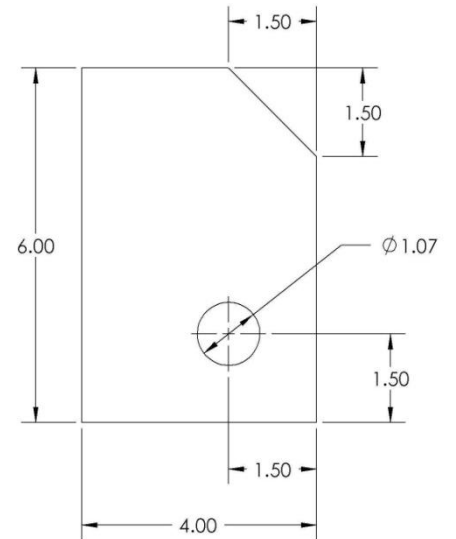

**Piece Parts Assembly**

**Side Plates**

You need 2 of these which are mirror images of each other.

1. Torch or shear the plate as shown (right).
2. Weld the Side Brace Plates and Large Tubes as shown (below).

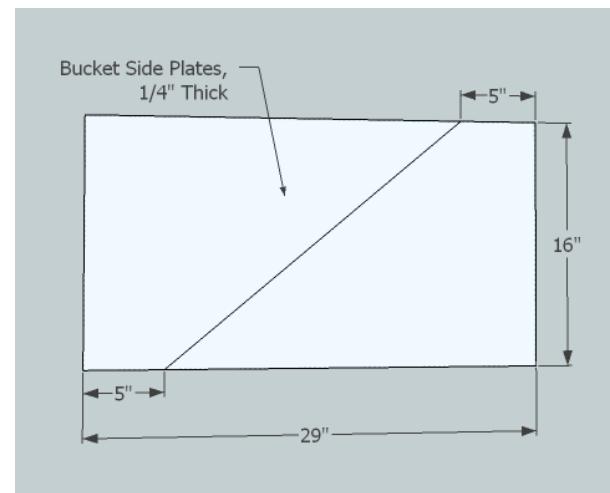
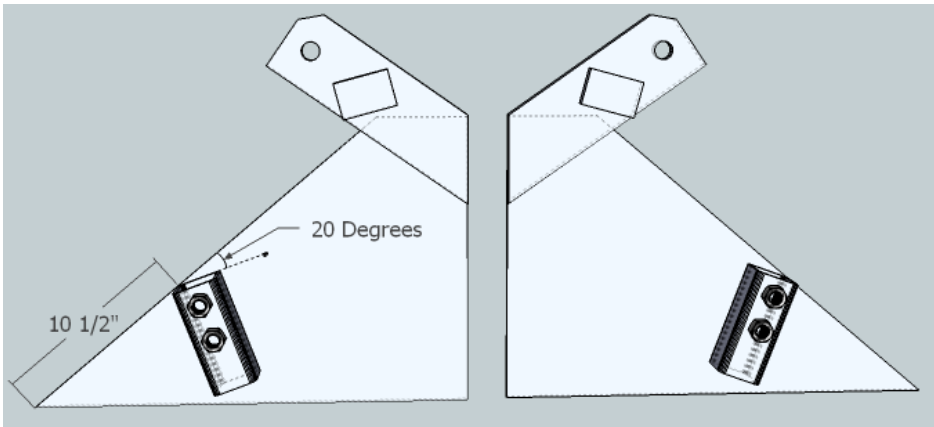

**Back Plate**

- Fully weld the bottom mounting plates to the back plate as shown.
- Insure they are square and do not warp while welding.

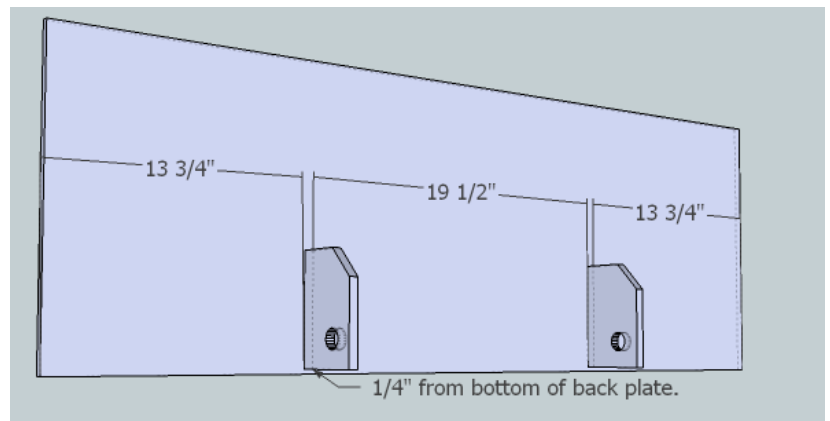

### Bottom Plate

- Fully weld skid plates and blade to the bottom plate as shown.
  - Only weld them from the bottom side, NOT the top or sides yet.
  - Insure you get the right spacing on them by looking at the lower diagram.
  - The blade will stick out  $\frac{1}{2}$ " on each side, and the skid plates will stick out  $\frac{1}{4}$ " on each side.

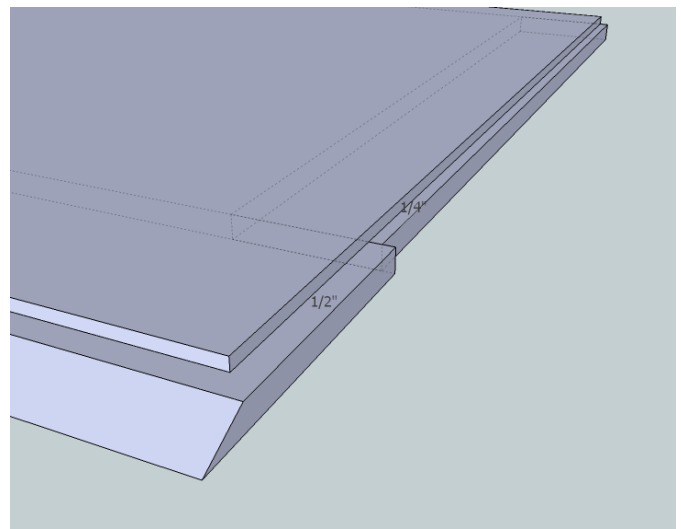
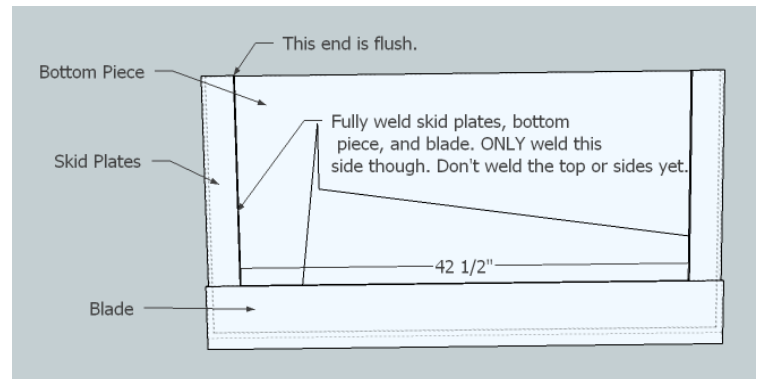

### Cross Supports

- Weld the Cross Support Plate, Cross Support Plate Lower, and Triangle Plates together as shown, with one Triangle Plate at each end of the supports.
  - Fully weld all seams except the one shown.

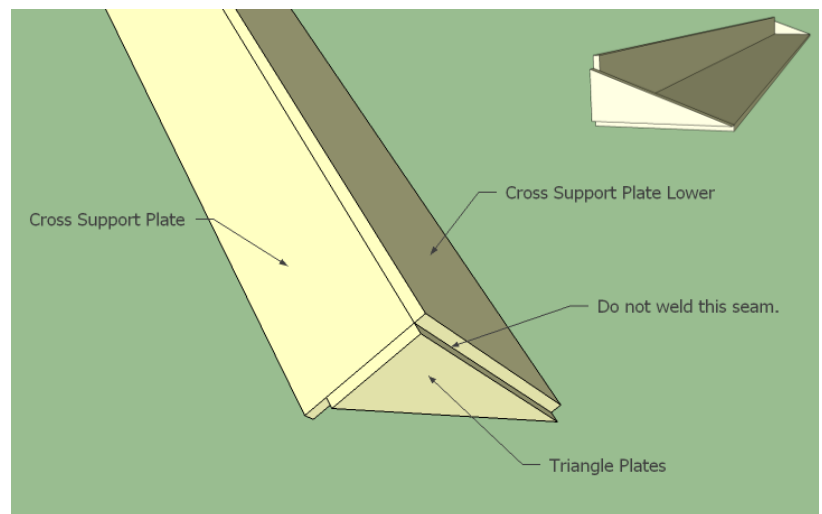

## Parts Assembly

### 1. Weld Bucket Plates

Fully weld the side plates, bottom plate, and back plate together at all joints as shown below.

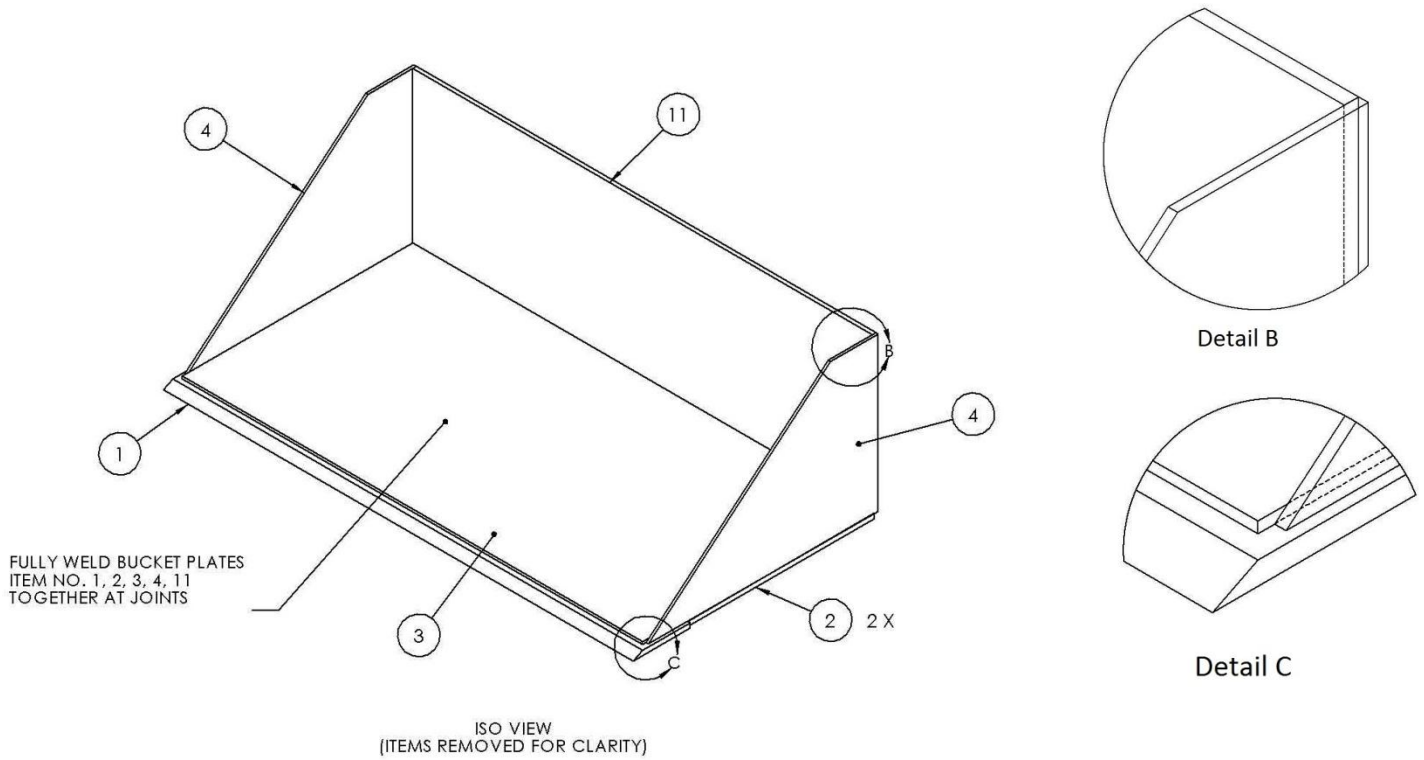

### 2. Weld Cross Supports

- Weld Cross Supports as shown.
  - Fully weld all seams except the one marked not to.

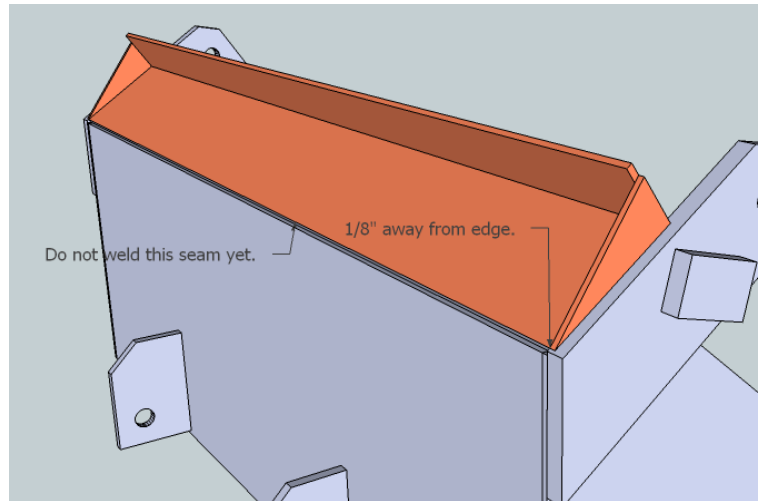

### 3. Weld Rear Mounting Plate

- Weld it in place, from all angles, as shown, at a 45° angle with the back plate.

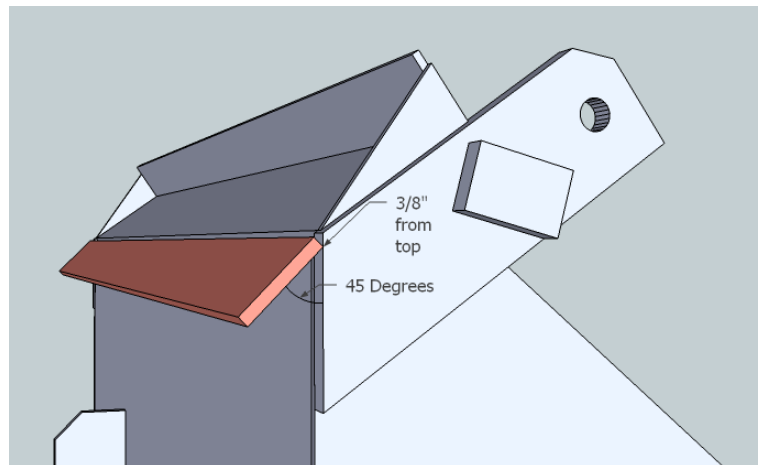

## Parts Fabrication - Frame Pivot Hinge

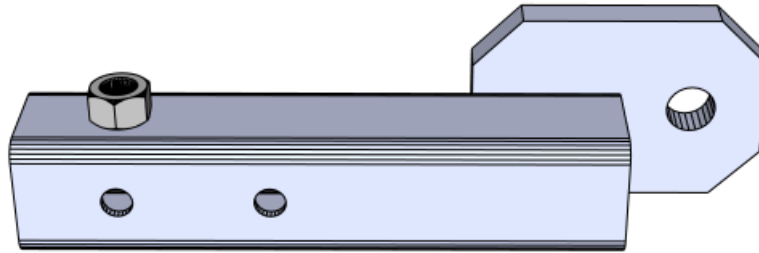

### Tools:

- Torch
- Welder
- Angle Grinder
- Hole Puncher

### Materials:

- .75"x4" Flat- 6" (2) – Joint Plate
- 2.5"x2.5"x3/16" Square Tubing- 12" (2) – Large Tube
- .75" Nut, Steel (2)

## Procedure

### Joint Plate

You need 2 of these.

1. Punch the hole as shown.
2. Torch away the corners as shown.

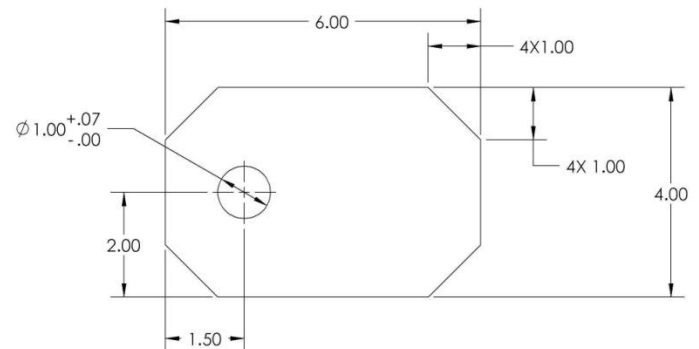

### Large Tube

You need 2 of these.

1. Torch the holes as shown.
  - Insure a .75" bolt can go thru the big hole.
  - Insure the 1/2" rod can go all the way thru the tubing through the smaller holes.
2. Grind away the slag.

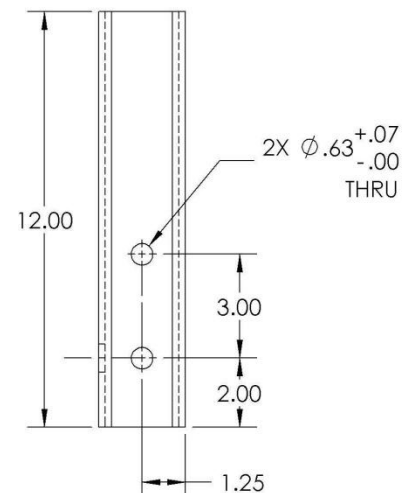
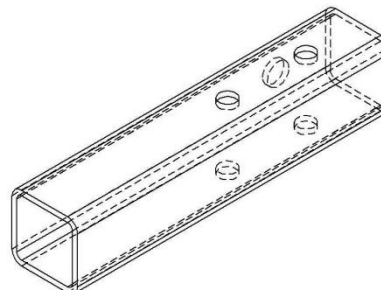
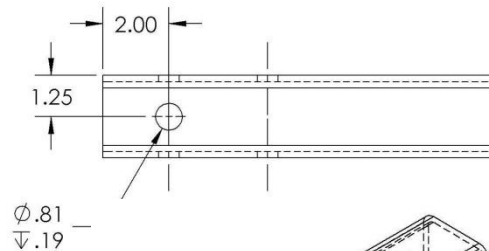

3. Fully weld the nut and Joint Plate to the Large Tube as shown.
- The two will be mirror images of each other.
  - When welding the nut, cover the top of the nut so no spatter goes inside, and insure the hole is clear and the nut level.

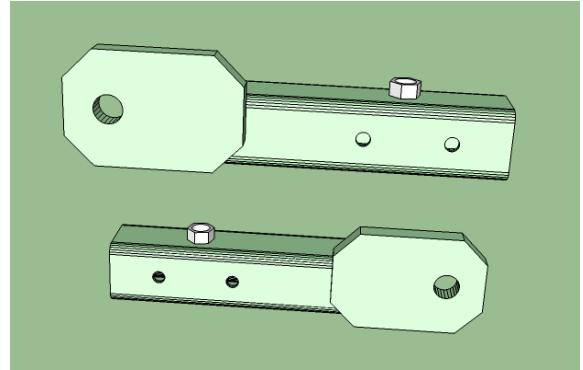
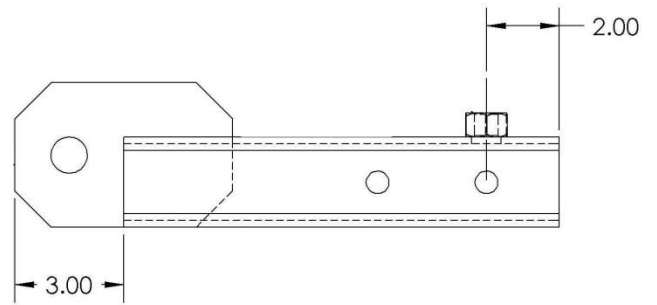

## Parts Fabrication - Arm Rest

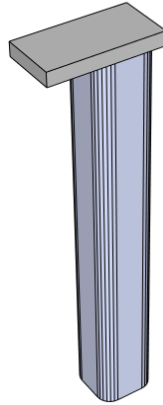
**Tools:**

- Welder

**Materials:**

- 2"x2"x1/4" Square Tubing- 13.5" (2)
- 1/2"x2 Flat- 4" (2)

**Steps:**

You need two of these.

- Fully weld the plate to the tubing as shown.

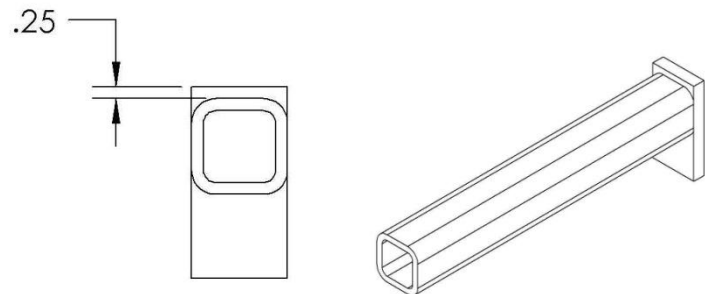

## Parts Fabrication - Shaft and Motor Frame

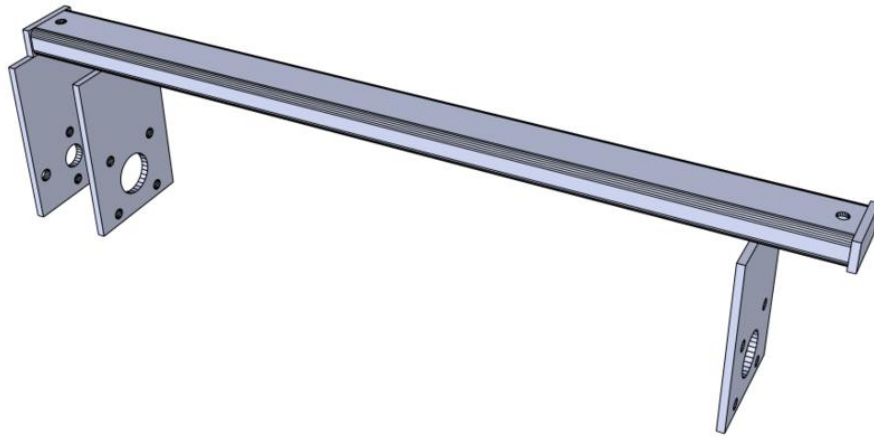

### Tools:

- Torch
- Welder
- Hole Puncher
- Angle Grinder

### Materials:

- 1/2"x2" Flat- 4.25" (2) – End Plates
- 1/2"x8" Flat- 12" (3) – Bearing and Motor Plates
- 2"x4"x1/4" Rectangular Tubing- 56" (1) - Cross Tube

## Parts Preparation

### Motor Plate

You need 1 of these.

1. Punch the smaller holes.
2. Torch the larger hole.
3. Grind it smooth.

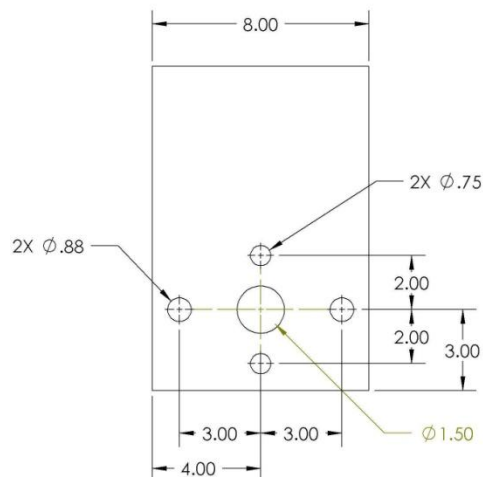

### Bearing Plate

You need 2 of these.

1. Punch the smaller holes.
2. Torch the larger hole.
3. Grind it smooth.

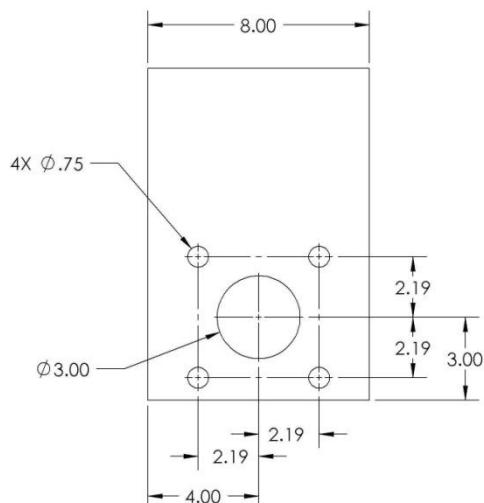



**Cross Tube**

1. Torch the holes shown.
  - Insure .75" bolts will go all the way through the tube.
2. Grind away the slag.

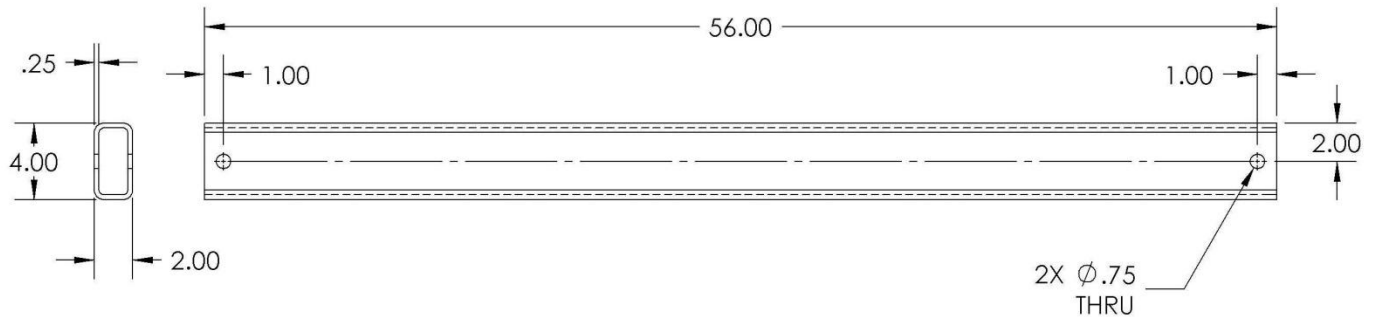
**Parts Assembly**

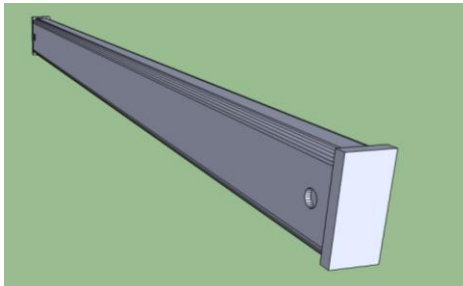
1. Fully weld the end plates centered to each side of the cross tube.
 
2. Fully weld the motor and bearing plates to the cross tube.
  - It is crucial that these all be square in every direction! Double check it, and weld it slowly so it doesn't warp.
  - Note that the motor plate is welded to the end plate.

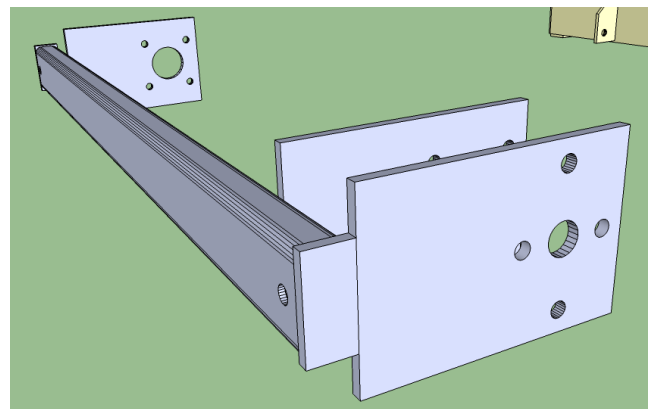
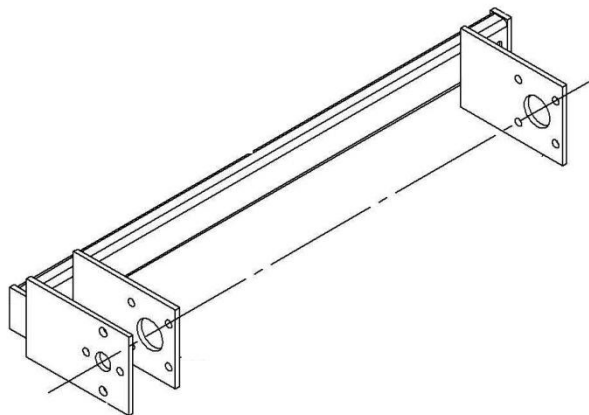
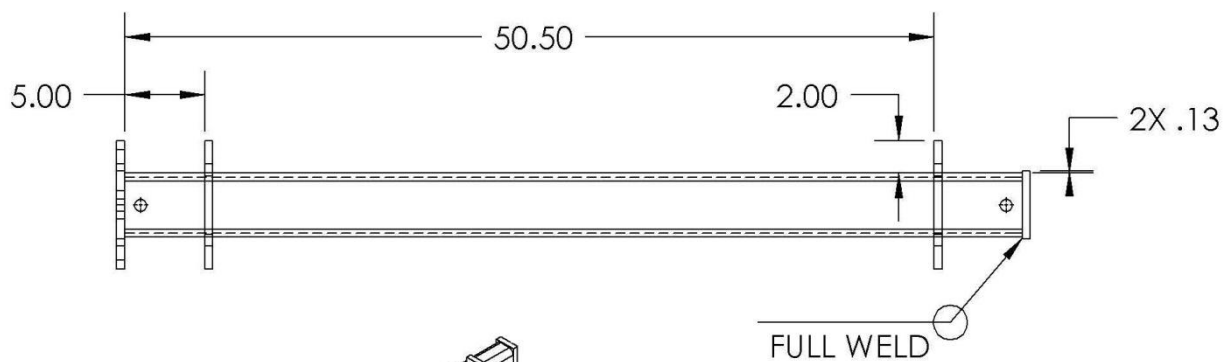

## Tines

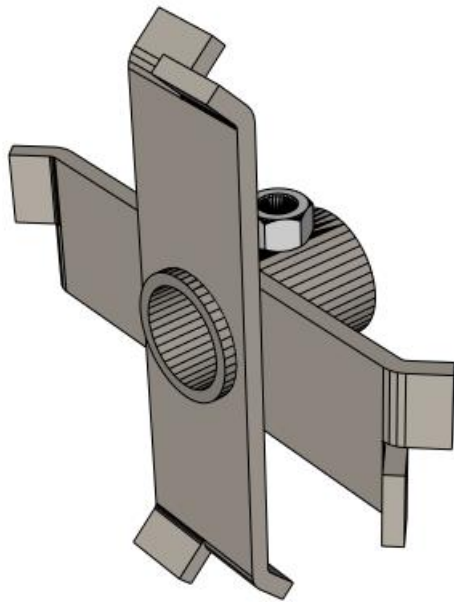

1 Note: Tines will not have bent tips until a later step.

### Tools:

- Torch
- Welder
- Hole Puncher
- Angle Grinder

### Materials:

- .375"x3" Flat- 11.5" (24)
- 2" Sch. 80 Pipe- 3.5" (12)
- .75" Nut, Steel – (12)

You need to make 12 of these total.

## Procedure

### Prepare the tines:

1. Torch a hole in the center of each flat as shown.
  - Check that the pipe will go through it.
2. Torch approximately 1" slits at each side of flat as shown.
3. Grind away any slag.

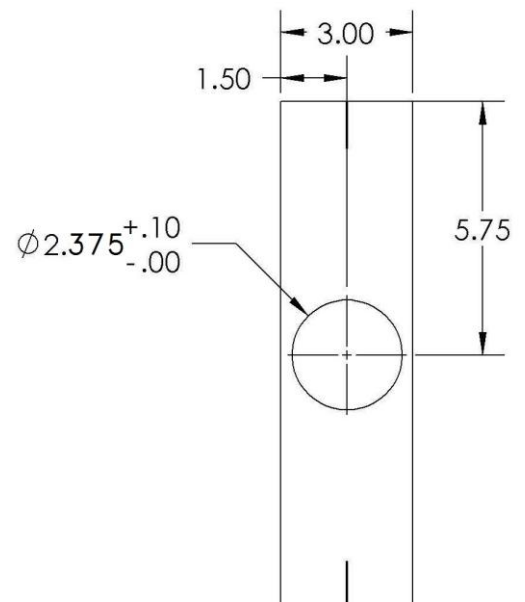

**Prepare the Pipe:**

1. Torch a hole in the pipe as shown.
  - Insure a .75" bolt will go through.
2. Grind it smooth.
3. Weld a nut over the hole, insuring the hole remains clear.
  - Protect the threads while welding.

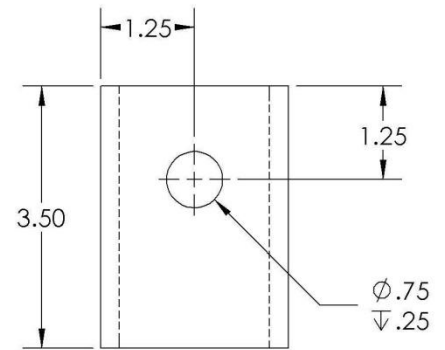
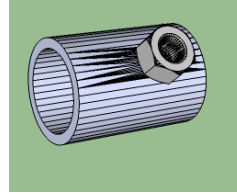
**Weld the tines to the Pipe:**

1. Weld the tines onto the pipe as shown.
  - They should be perpendicular to each other.
  - The one closest to the end should be .25" away from the edge of the pipe.
  - Fully weld all joints.
  - Make sure no spatter enters the nut

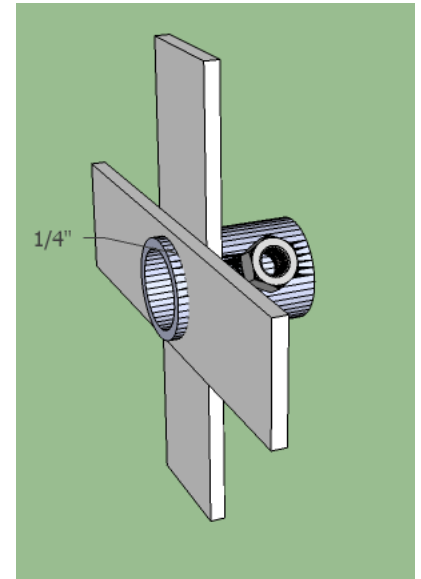

## Parts Fabrication - Coupler

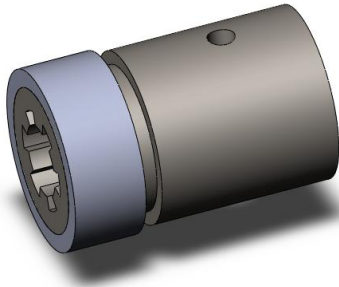

### Tools:

- Bandsaw
- Welder
- Drill Press with 3/8" bit.

### Materials:

- Coupler, 1-3/8" 6T Splined
- 2" Sch. 80 Pipe- 2.5" (1) – Shaft side coupler
- 2" Sch. 40 Pipe- 1" (1) - Sleeve
- 1.875" Round – 52" (1) – Shaft
- 3/8"x3" bolt

### Procedure

Note: if you have access to a lathe, you can simply lathe out about 1/8" long section of the splined coupler so it fits directly into the Sch 80 pipe. This ensures concentricity. You could do away with the sleeve and weld these two directly together.

1. Cut down the splined coupler so it is 1.25" long.
2. Tack it to the sleeve as shown.
- If there's any play, get the coupler as centered as possible in the sleeve.

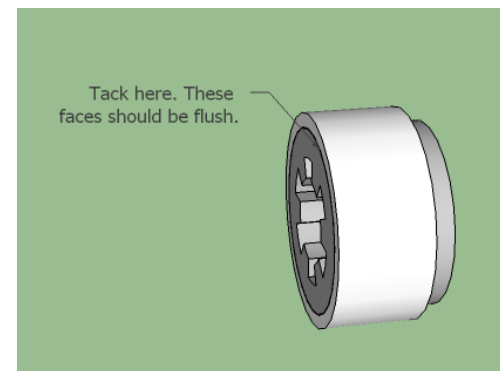
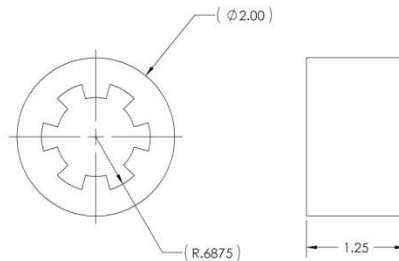

3. Tack the pipe and coupler with sleeve together as shown.
  - Insure that the sleeve and the pipe are concentric!! This is a critical part.
  - It would help to set the two on the welding table and tack from the top, then twist until they're perfect.
4. Tack them in many dimensions to insure nothing warps.
5. Weld it fully, with at least 3 layers of weld.

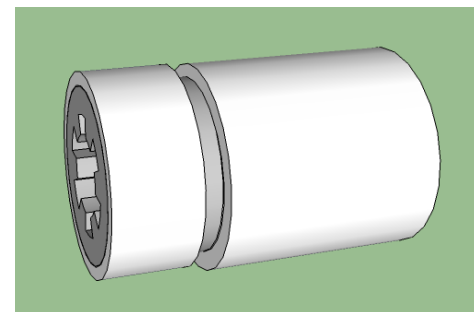

6. Mark and center punch where the hole in the pipe will be.

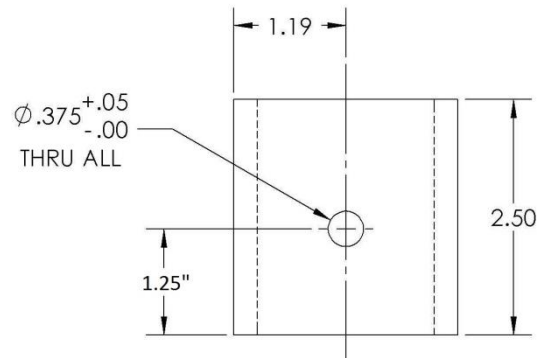

7. Insert the shaft fully into the coupler.
8. Drill through the coupler and the shaft.
9. Insure the 3/8" bolt goes through both the coupler and the shaft. If not, re-drill with a slightly larger bit.

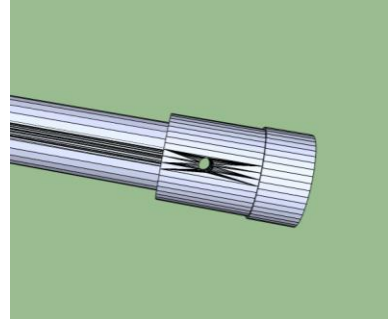

# Parts Fabrication - Additional Piece Parts

**Tools:**

- Torch
- Angle Grinder
- Welder
- Hole Puncher
- Drill Press

## Small Tube

**Materials:**

- 2"x2"x.25" Square tubing- 24" (2)

You need to make 2 of these.

**Steps:**

1. Torch all holes as shown.
  - Insure the proper size bolt or rod can go through each hole.
2. Grind away all slag.

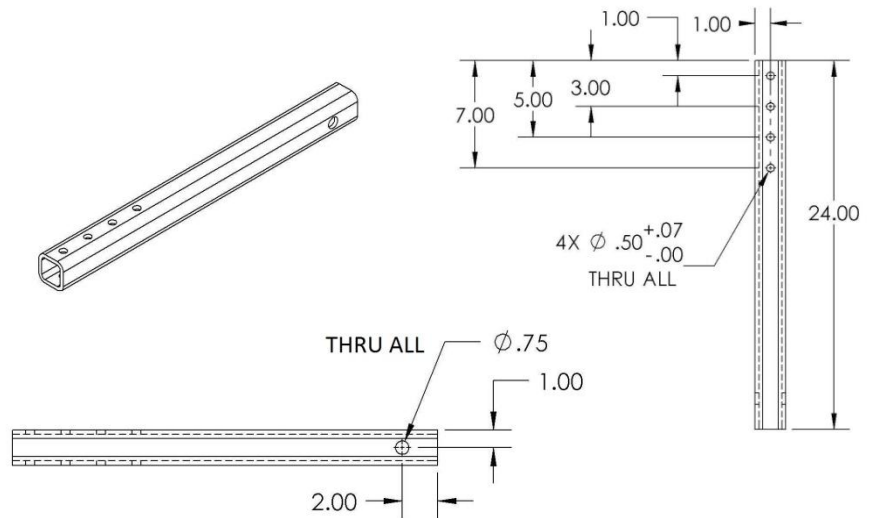

## Motor Mount Plate

**Materials:**

- 1/2"x6" Flat- 8" (1)

**Steps:**

1. Punch the smaller holes as shown.
2. Torch the center hole.
3. Grind away the slag.

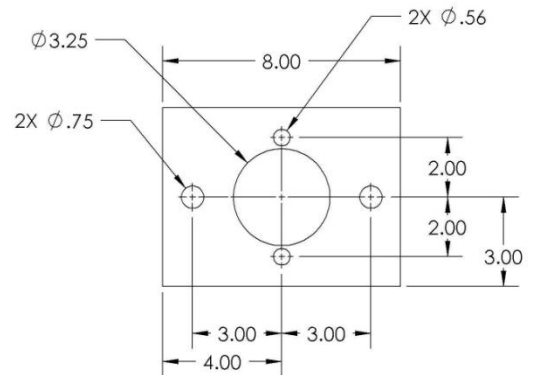

## Hinge Rod

**Materials:**

- .5" Round- 50" (1)

**Steps:**

1. Drill a hole as shown at each end of the rod.

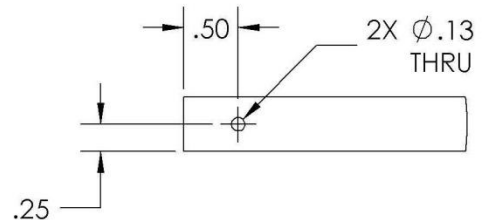

## *Hinge Pin*

**Materials:**

- .5" Round- 4" (2)

You need 2 of these.

**Steps:**

1. Drill the holes as shown.

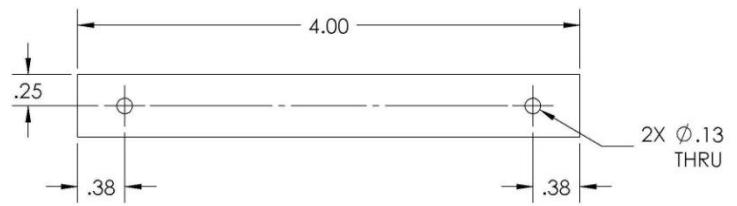

## Assembly- Front Frame

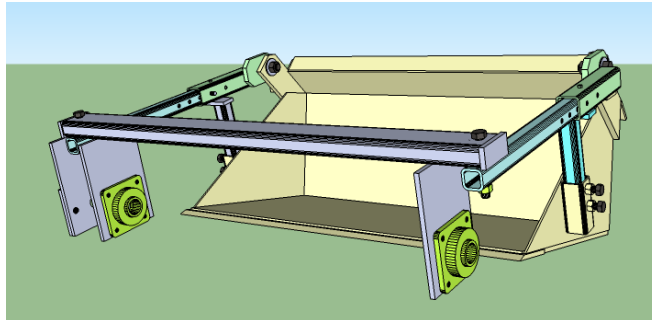

An [assembly video](#) is also available. Note that not all steps will be the same, as some parts still need to be welded or bent. Follow the written instructions.

### Tools:

- Various Wrenches

### Materials:

- Assembled Parts:
  - Bucket
  - Arm Rests
  - Frame Pivot Hinges
  - Shaft and Motor Frame
- 1 7/8" Bearings (2)
- 1/8" x 2.5" Cotter Pins
- Fasteners
  - 1"x3"x2.25" Bolts (2)
  - 1" Washers (4)
  - 1" Nuts (2)
  - 3/4"x5.5"x1.75" Bolts (2)
  - 3/4"x1.25" Bolts (2)
  - 3/4"x1.5" Bolts (4)
  - 3/4" Nuts, Galvanized (2)
  - 9/16"x2" Bolts (8)
  - 9/16" Nuts (8)
  - 9/16" Washers (8)

### Procedure

1. Insert the Arm Rests into the Arm Rest Slots in the side of the Bucket as shown.
  - Make sure the arm rests have the correct orientation. See the illustration.
2. Insert and tighten both 3/4"x1.5" bolts on each side to hold them in place.
  - The arm rests should both be sticking up about 8" from the slots.

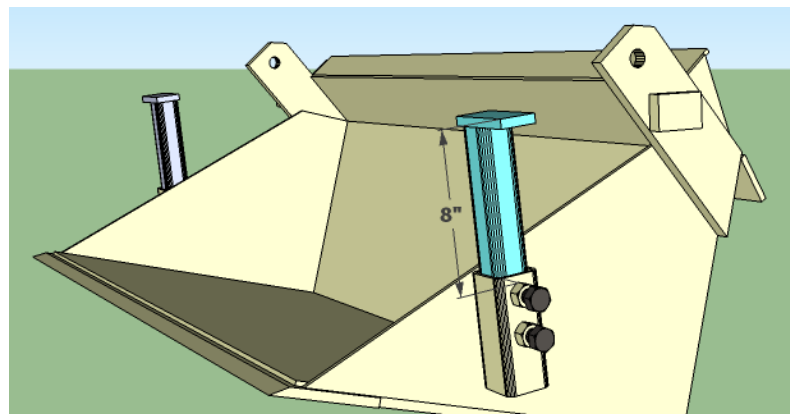



3. Bolt the Frame Pivot Hinges to the top side of the bucket so it rests on the arm rests.
  - Make sure they both have the right orientation by looking at the image.
  - Use the 1" bolts and nuts with a washer on each side.
  - Tighten the bolt, but leave a little space so the Pivot Hinges are free to rotate.

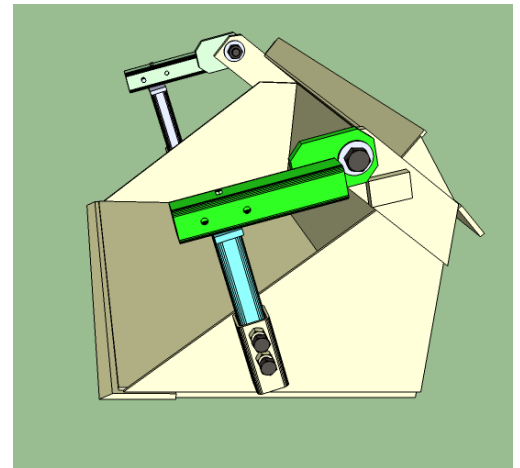

4. Insert the Small Tubes into the pivot hinge, as shown, so that the  $\frac{3}{4}$ " holes are on the outside of the bucket.

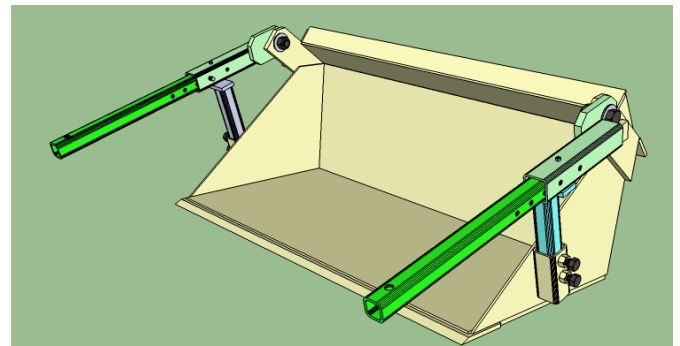

5. Put the hinge pin through both sets of tubing as shown on each side.
  - Which holes you put it through are not crucial, as this can be adjusted later. However, insure both small tubes are adjusted the same..
  - Put the cotter pins though each side of the pin.
6. Tighten a  $\frac{3}{4}$ "x1.25" bolt into the nut welded to each pivot hinge.

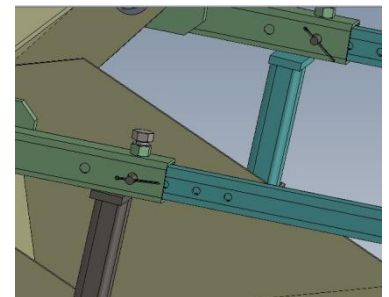

7. Bolt the Shaft and Motor Frame to the Small Tubes as shown.
  - Use the long  $\frac{3}{4}$ " bolts. You need washers on each side of the bolts.

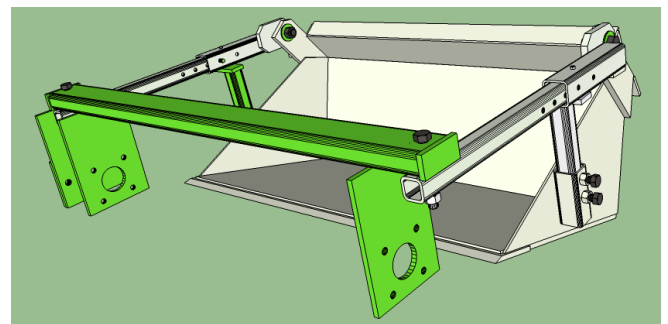

8. Loosely bolt the bearings to the shaft and motor frame as shown.
  - You will tighten the bolts in a later step.
  - Use the  $\frac{9}{16}$ " bolts, with a washer near the nut.

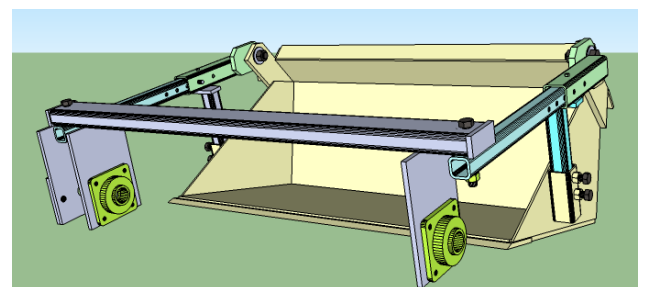

## Assembly- Bend the Tines

### Tools:

- Pipe wrench
- Mallet

### Materials:

- Assembled Parts:
  - Tines
  - Bucket/Front Frame
  - Shaft

### Procedure

1. Hammer the shaft through one bearing as shown, so the hole for the coupler is positioned as shown.
  - Angle it to the side to allow room for the tines to slide on.
2. Slide all tines on the shaft so they are all oriented in the same direction, as shown.

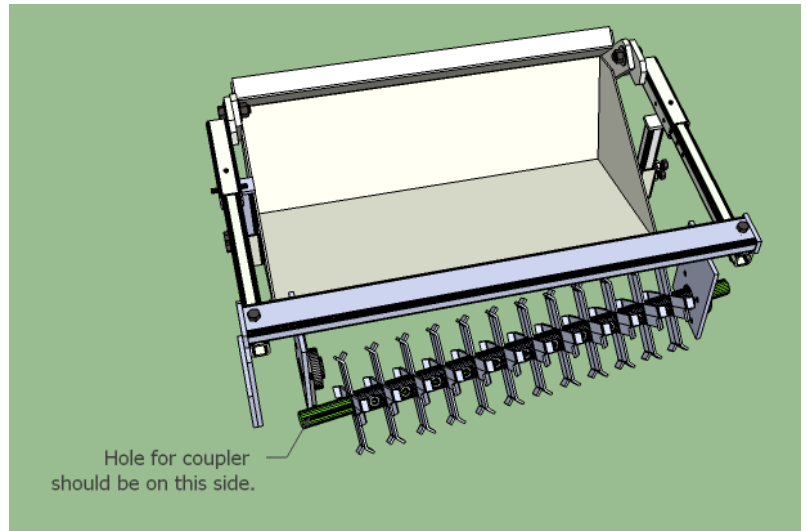

3. Use a pipe wrench to bend each of the tines as shown. If it is too difficult, you can use a torch to heat them up.
  - Their shape doesn't need to be precise.
  - Make sure you bend each piece as in the lower image.

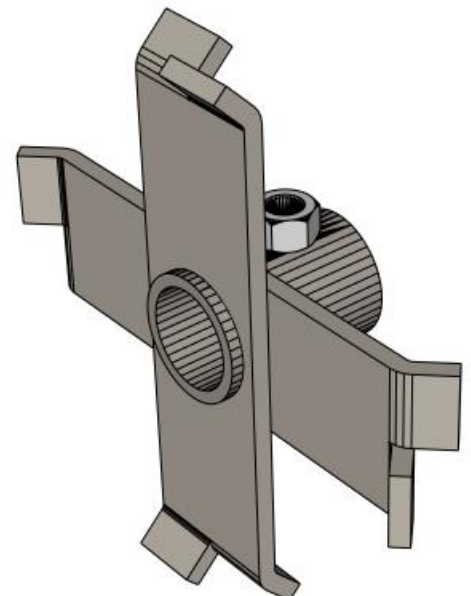
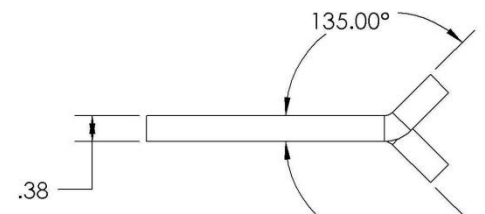

## Assembly- Install the Shaft and Motor

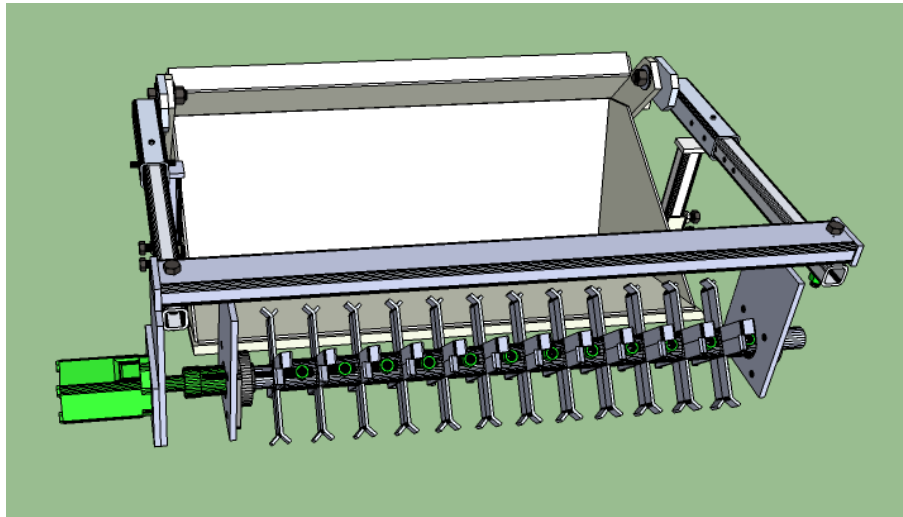

### Tools:

- Mallet
- Various wrenches
- Ratchet/ socket set
- Socket extension
- Allen Wrench
- Loctite

### Materials:

- Assembled Parts:
  - Bucket/Front Frame
  - Motor Mount Plate
- Motor
- Lock Collars for Bearings
- $\frac{3}{4}$ "x1.25" Bolts (12)
- $\frac{3}{4}$ "x2" Bolts
- $\frac{3}{4}$ " Nuts, Galvanized (2)
- $\frac{3}{4}$ " Washers (2)
- $\frac{1}{2}$ "x2.5" Bolts (2)
- $\frac{1}{2}$ " Nuts (2)
- $\frac{1}{2}$ " Washers (2)
- $\frac{3}{8}$ "x3" Bolt (1)
- $\frac{3}{8}$ " nut (1)

### Procedure

1. Place the lock collars on the shaft as shown.
  - Be sure they are in the right orientation to lock onto the bearings.
  - Don't lock them yet, you'll do this later.
2. Angle the shaft properly, and hammer it through the other bearing until it's poking through the bearing mount plate about 1".

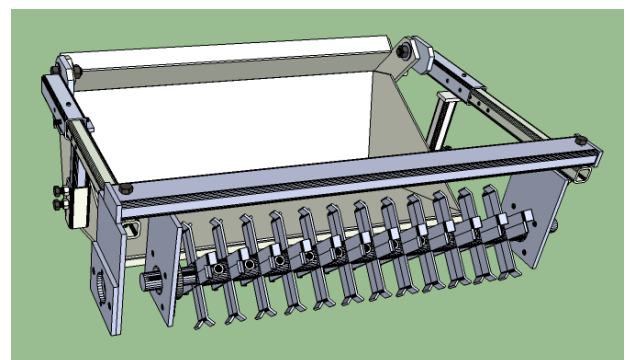
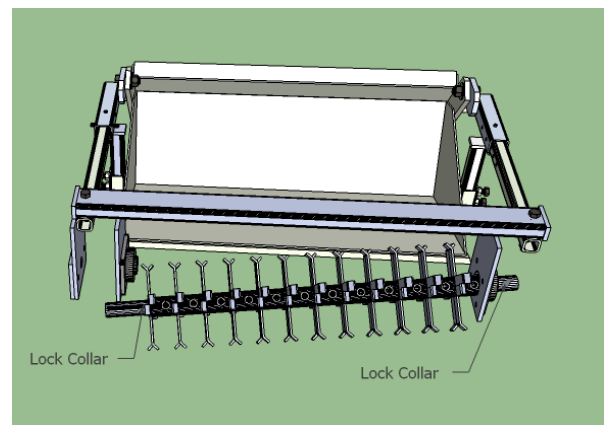

3. Install the coupler onto the shaft.
  - Insert the coupler onto the shaft.
  - Once the coupler is on, hammer the shaft through until it is fully inserted in the coupler and it is positioned as in the photo on the right.
  - Rotate the coupler so that the holes in the coupler and the shaft line up.
  - Insert the 3/8" bolt through the hole and tighten the nut onto it. Use loctite on the bolt.

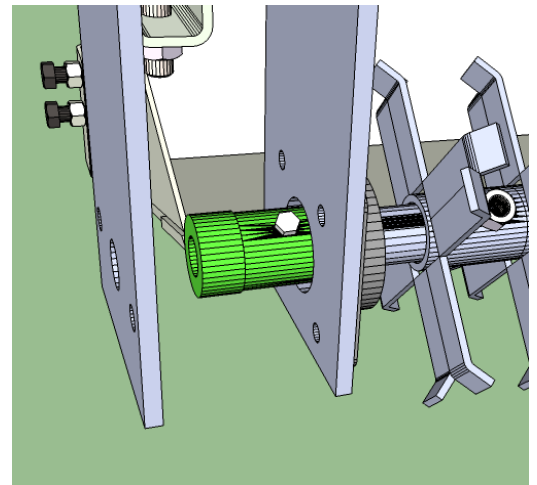

4. Loosely bolt the motor mount plate to the frame, using the 3/4"x2" Bolts.
  - Use a washer the side of the nut.

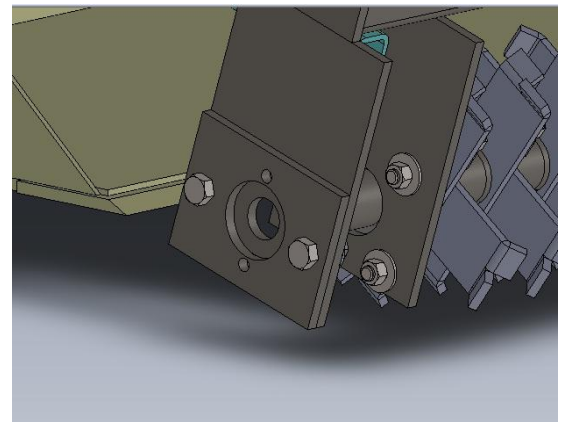

5. Slide the motor through the mount and into the coupler.
  - Make sure the motor is oriented so that you will be able to bolt it to the frame.
  - You may need to rotate the motor shaft, or the shaft with the tines on it to get the motor shaft to fit into the coupler.
  - Don't insert it all the way yet, just get it started.

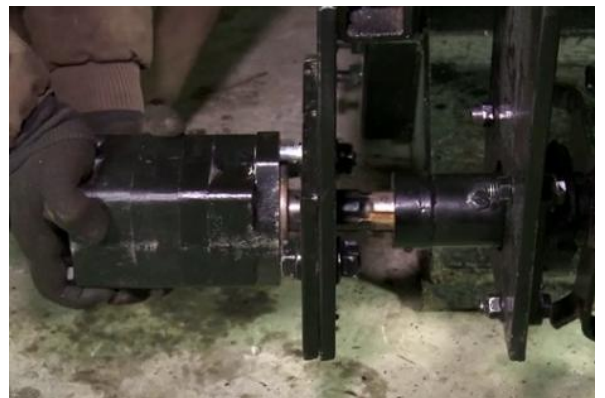

6. Loosely bolt the motor to the frame, with the 1/2"x2.5" bolts, with a washer on the side of the nut.
7. Lightly hammer the motor until it is flush with the motor mount plate.
8. Tighten the bolts on the motor and the motor plate.
9. Tighten the set screw on the coupler and the bearing lock collars.
10. Tighten 3/4"x1.25" bolts into each tine, using a socket with an extension.

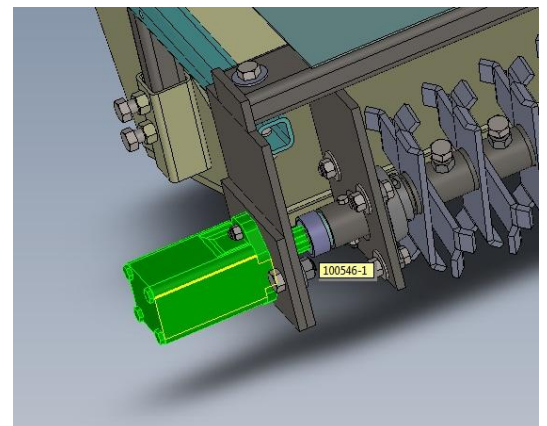

## Assembly – Install the Top Plate

### Tools:

- Welder
- Mallet

### Materials:

- Assembled Parts:
  - Bucket/Front Frame
  - Hinge Rod
- .5 ID x .75 OD Round Tubing- 2” (8)
- 1/8” Sheet- 40”x48” – Top Plate
- 1/8”x2” Cotter Pins (2)

### Procedure

1. Lay the top plate onto the frame as shown.
2. Insert the pipe onto the Hinge Rod as shown, and position pipe and rod as shown.
  - Space the pipes approximately as shown, so they are in 4 sets of 2, evenly spaced.
3. Position the top plate and rod/pipes approximately as shown on the right.
4. Weld one pipe from each set to the cross support piece, and one to the top piece.
  - Protect the shaft so that no welding spatter sticks to it.
  - Weld the highlighted ones in the photo above to the top piece, and all others to the cross support piece.
5. Insert the cotter pins into the holes at each end of the rod.

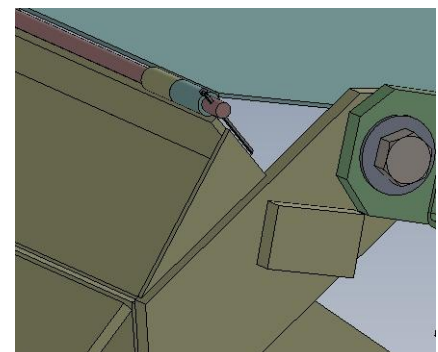
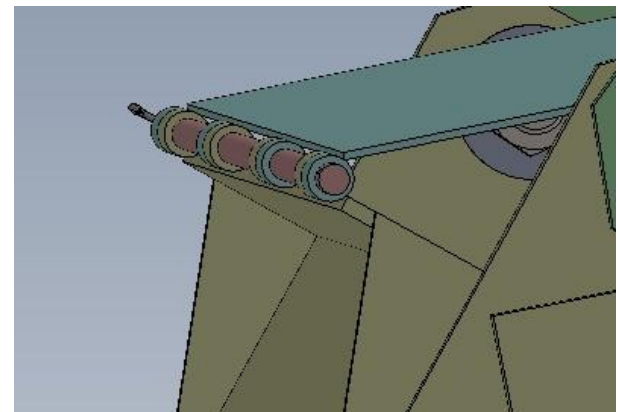
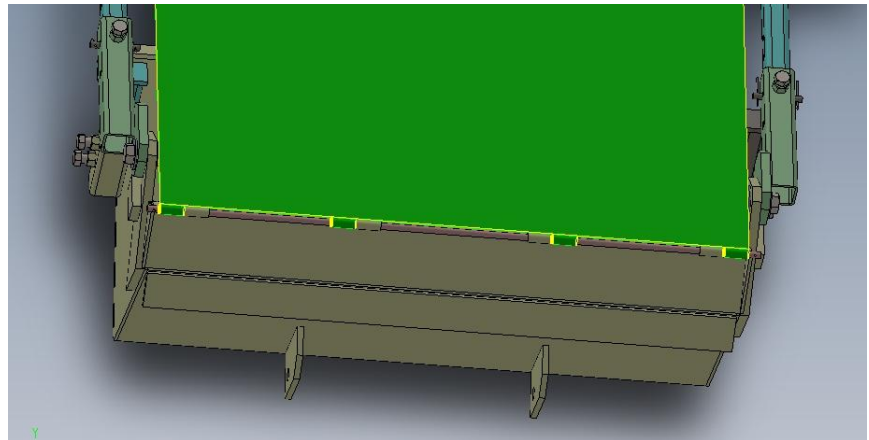

## Assembly- Paint

### *Procedure*

1. Check all external surfaces for sharp edges and smooth with angle grinder.
2. Remove any surface rust with wire brush and / or sandpaper.
3. Apply a thorough coating of paint to all steel surfaces.
  - You will need to prop up the top piece while painting, so you can paint everything.
  - Do not paint the motor.
4. Allow 24 hours to dry before handling.

## Assembly – Hydraulics

### Tools:

- Rags
- Jar
- Various Wrenches
- Thread Tape

### Materials:

- SAE 10 to 1/2 NPT swivel (2)
- SAE 4 to 1/4 NPT swivel (1)
- 30 gpm Quick Coupler set, Body Size: 1/2, Thread Size: 3/4-14 NPT (3)
- 1/4" Quick Coupler set (1)
- 1/4" Male quick coupler (1)
- 1/4 NPTM x 12' Hose (1)
- 1/2 NPTM x 12' Hose (2)

### *Procedure*

#### Prepare the hoses

- To each hose, attach a male quick coupler at one end and a female at the other.
- Use thread tape between each connection.

#### Assemble motor hydraulics

1. Remove the plugs in the motor.
  - Have rags and a jar ready in case there is fluid in the motor.
2. Install the swivels into the ports as shown in the photo.
  - Do not use thread tape on the swivel fittings.



3. Install the quick couplers as shown on the right, using thread tape for each connection.

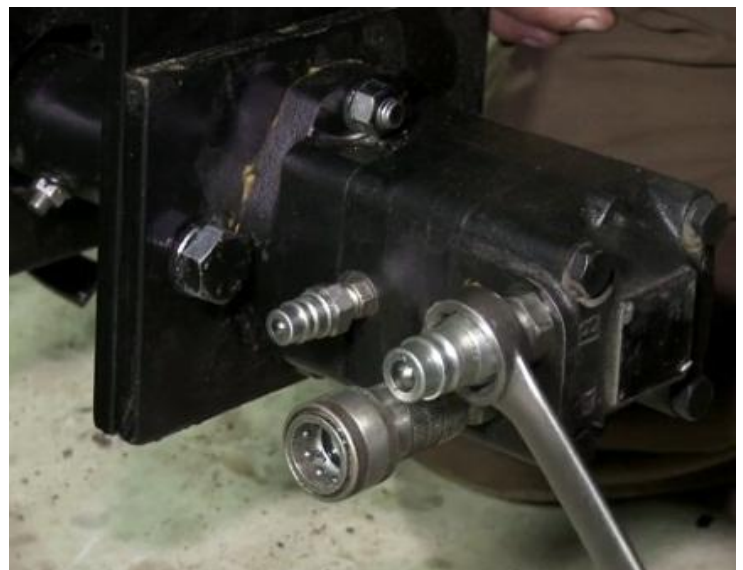

4. Attach the hoses to the quick couplers in preparation for attaching to a hydraulic power source.

