

USER MANUAL

PD 6500*i*
MODEL 11684xx

GARRETT
METAL DETECTORS

USA

Security Division
Garrett Metal Detectors
1881 West State Street
Garland, Texas 75042-6797 USA

Phone: (800) 234-6151
Fax: (972) 494-1881
Email: security@garrett.com
Website: www.garrett.com

OUTSIDE USA

International Division
Garrett Metal Detectors
1881 West State Street
Garland, Texas 75042-6797 USA

Phone: (972) 494-6151
Fax: (972) 494-1881
Email: international@garrett.com
Website: www.garrett.com

MANUFACTURER CAUTION

Read Thoroughly Before Operating



CAUTION! Use of this equipment in a manner not specified by the manufacturer may result in damage to property or injury to persons.

Electrical: 100 – 240 V~ +10% – -15%
1.0 - 0.5A
50/60 Hz
Installation Category: II
Pollution Degree: 2
Maximum Relative Humidity: 95% non-condensing
Operating Temperature: -4°F (-20°C) to +158°F (70°C)
Maximum Altitude: 3000 meters

Place the PD 6500i in an area where it is protected from direct rain, mist and / or condensation and position it on a level, stable floor free from vibration.



CAUTION! PD 6500i may be firmly anchored to the floor or optional stabilizer base attached to reduce the risk of injury to persons or property damage due to accidental knock down.

SYMBOLS:



Alternating current



Protective conductor
terminal



CAUTION! Risk of
electric shock





CAUTION! Refer
to accompanying
documentation

Garrett Metal Detectors and garrett.com are trademarks and registered trademarks of Garrett Electronics, Inc. If further assistance is required, please contact the factory using contact information on front cover.

TABLE OF CONTENTS

1.	GENERAL DESCRIPTION OF PD 6500i	5
1.1	TECHNICAL SPECIFICATIONS	6
1.2	REGULATORY INFORMATION	6
1.3	DESCRIPTION OF CONTROLS, DISPLAYS AND ALARMS	8
2.	INSTALLATION	11
2.1	SITE SELECTION & REQUIREMENTS	11
2.2	UNIT ASSEMBLY	16
2.3	PLACEMENT PROCEDURE	19
2.4	MULTIPLE WALK-THROUGH SITE INSTALLATION SETUP	20
3.	MENUS	22
3.1	MENU TABLE	23
3.2	POWER ON / OFF	24
3.3	SELF TEST	24
3.4	USER ACCESS	24
3.5	MENU ITEMS	24
3.6	CODE RESET	33
4.	PROGRAMS	34
5.	MAINTENANCE / TROUBLESHOOTING	35
5.1	WARRANTY INFORMATION	35
5.2	REPAIR	36
5.3	REPLACEMENT PARTS LIST	38
5.4	ERROR CODE TABLE-DIAGNOSTICS	39
6.	ACCESSORIES	41
6.1	BATTERY BACK-UP	41
6.2	AC & DC CONTROL	41
7.	ADDITIONAL INFORMATION	43
7.1	SECURING THE POWER CORD	43

1. GENERAL DESCRIPTION OF PD 6500i

- Basic Description** The Garrett PD 6500i (Model #11684xx) is a digitally controlled pulse induction metal detector.
- Memory** All program selections and settings are maintained in electrically erasable non-volatile memory. The unit will maintain all settings even when disconnected from power. No battery is required for memory retention.
- Unique Target Pinpointing** The Garrett PD 6500i is an advanced Digital Signal Processor (DSP) - based walk-through metal detector that provides superior target detection with excellent metal discrimination capabilities. Multiple targets are pinpointed on the left, center or right side of the body from head to toe within 33 distinct areas using a unique array of Light Emitting Diodes (LED's) located on the exit side of each panel. Independent zone by zone calibration capability insures optimal archway field uniformity, regardless of installation challenges.
- Improved Sensitivity** An improved multi-coil design allows programming for the detection of the smallest of metallic targets regardless of shape and orientation.
- Traffic Flow** Pacing lights with international "wait" () and "proceed" () symbols are located on the entrance side of each panel and allow smooth and efficient traffic flow. The PD 6500i traffic counter tracks the number of patrons that have passed through the detector, the number of alarms and calculates the alarm percentage.
- Security** All settings are secured with a key lock and 3 levels of user access. Further security is accomplished with a cabinet lock which prevents unauthorized access to cables, connectors and circuit boards.
- Controls/ Displays** The PD 6500i utilizes backlit Liquid Crystal Displays (LCD's) and LED bar graphs for continuous on-line operating status and self-diagnostic reporting. All controls and settings are simplified with menu selections and touchpad controls.
- Optional Accessories** Optional accessories include a Battery Back-Up Module for emergency or remote use, a wheel assembly for easy portability, adhesive floor mounts and a computerized Control Monitor Analyzer (CMA) interface module. CMA software provides network capabilities for remote access to data collection, alarm statistics and real-time "detector events" for monitoring and / or analyzing.

1.1 TECHNICAL SPECIFICATIONS

1.1.1 DIMENSIONS

- Passage Interior: Width: 30" (0.76m) Height: 80" (2m) Depth: 23" (0.58m)
- Overall Exterior: Width: 35" (0.9m) Height: 87" (2.2m) Depth: 23" (0.58m)

- Shipping: Width: 35.5" (0.9m) Height: 92" (2.3m) Depth: 6.5" (0.17m)
Shipping Weight: 165 lbs (74 kg)

1.1.2 OPERATING CONDITIONS

Temperature: -4°F (-20°C) to +158°F (70°C)
Humidity: Up to 95% non-condensing.

1.2 REGULATORY INFORMATION

The PD 6500i meets or exceeds all industry safety and electromagnetic compatibility (EMC) standards and conforms to international directives (CE approved).

Garrett research has produced no information which would indicate that Garrett products would have any adverse effects on medical implants, pregnancy, recording media or magnetic strips. Garrett consistently cooperates with medical device manufacturers and communicates with agencies such as the United States FDA (Food and Drug Administration) and Health Canada to continue the assurance of Garrett products' safety. Any recommendations or directives issued by personal physicians should be followed. If, for any reason (e.g., doctor's orders, etc.), a patron objects to being scanned with a metal detector, it is recommended that an alternative procedure (e.g., "hand wandling", "pat down", non-admittance, etc.) be a part of the overall security plan.

The PD 6500i is made of scratch and mar resistant laminate with resilient end caps, a control panel and heavy-duty aluminum crosspiece. Smooth rounded corner design ensures no puncturing, cutting or tearing of the skin or clothing or otherwise causing bodily injury. A key lock panel protects critical circuitry, wires, cables, data cables and power connectors to prevent tampering or injury.

1.2.1 ELECTRICAL SAFETY

The Garrett PD 6500i has been tested and found to comply with:

- Canadian Standard - CAN / CSA-C22.2 No. 1010.1 and CAN / CSA-C22.2 No. 1010.1B-97 Safety Requirements for Measurement, Control and Laboratory Use, Part 1: General Requirements.

- United States Standard - UL 3101-1 1993 Electrical Equipment for Laboratory Use, Part 1: General Requirements.

- International Standard (CB Certification) - IEC 610010-1 Safety Requirements for Electrical Equipment for Measurement, Control and Laboratory Use, Part 1: General Requirements.
- OSHA Regulation 1910.147 De-energizing Equipment.

1.2.2

MAGNETIC FIELD SAFETY

The Garrett PD 6500i has been tested and found to comply with:

- AICGH-0302 (1996), Sub-Radio Frequency (30 kHz and below) Magnetic Fields.
- Institute of Electrical and Electronic Engineers (IEEE) C95.1-1999, "IEEE Standard for Safety Levels with Respect to Human Exposure to Radio Frequency Electromagnetic Fields, 3 kHz to 300 GHz."
- International Commission for Non-Ionizing Radiation Protection (ICNIRP), "Guidelines for Limiting Exposure to Time-Varying Electric, Magnetic and Electromagnetic Field (Up to 300 GHz)."
- NBS Special Publication 500-101, "Care and Handling of Computer Magnetic Storage Media."
- Canada Health and Welfare: Performance Standards (Walk-Through), RPS-SC-18 section 3.2.2 which addresses the issue of electromagnetic effects to cardiac pacemakers.
- Occupational and Safety Health Administration: Radiation Protection Guide, CFR 1910.97 section (2) i.
- National Institute of Law Enforcement and Criminal Justice: Standards for Walk-Through Metal Detectors for use in Weapons Detecting NILECJ-STD-0601.00 Section 4.11.
- OSHA Regulation 1910.47 (a) (2) (i) Non-Ionizing Radiation.

1.2.3

ELECTROMAGNETIC COMPATIBILITY

The Garrett PD 6500i has been tested and found to comply with:

- FCC 47 CFR, Part 15, Subpart B: 1998, Class A for Power Line Conducted Emissions.
- FCC 47 CFR, Part 15, Subpart B: 1998, Class A for Radiated Emissions.
- EN 55022: 1998, Radiated Emissions for Class A Information Technology Equipment.
- EN 55024: 1998, for Immunity.

1.2.4

PHYSICAL

The Garrett PD 6500i has been tested and found to comply with:

- IEC 68-2-27, 29 for Shock and Bump.
- ASTM F1468-95 Section 5.4 Tip Over (requires anchoring).
- IEC 529 IP42 for protection from water and foreign objects.

1.2.5 PRODUCT PERFORMANCE

• The PD 6500i is Transportation Security Administration (TSA) qualified to meet the new Enhanced Metal Detector (EMD) specification for walk-through metal detectors.

The Garrett PD 6500i has been tested and found to comply with:

- Federal Aviation Administration (FAA) three-gun test.
- National Institute of Law Enforcement and Criminal Justice Standards #0601.00, levels 1-5.
- NIJ Standard 0601.02 Walk Through Metal Detectors for use in concealed weapons and contraband detection

1.3 DESCRIPTION OF CONTROLS, DISPLAYS AND ALARMS

1.3.1 DESCRIPTION OF VISUAL CONTROLS AND DISPLAYS

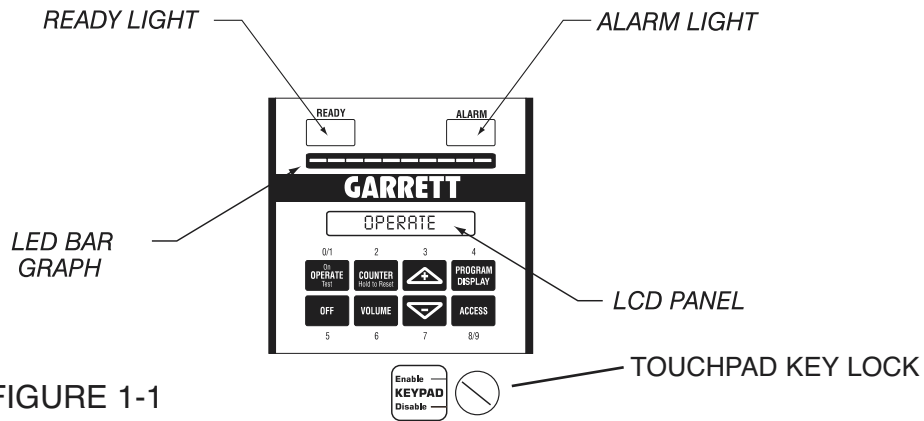

FIGURE 1-1

1.3.1.1 BAR GRAPH

The LED bar graph is comprised of a series of lights. The bar graph light activity represents the level of metal detection intensity occurring within the archway. The detection intensity is dependent upon the quantity and composition of the metallic object(s), and the program and sensitivity settings of the unit.

The bar graph also indicates the presence of electrical interference and interference from nearby moving metallic objects.

1.3.1.2 READY LIGHT

The green READY light appears when power is on and the PD 6500i is ready to detect metal. The ready light must be illuminated before a patron is permitted to enter the walk-through.

1.3.1.3 BACKLIT LCD

The LCD is a visual display located in the overhead panel. The LCD reports calibration and operational information, including program and sensitivity settings, operator functions and fault indication. The LCD displays

all self-prompting regulation and control functions as well as traffic count information.

1.3.1.4 **ALARM LIGHT**

The red ALARM light is a visual indication of an alarm when the unit detects a targeted amount of metal within the walk-through according to the program and base sensitivity settings. When a target is detected the alarm light appears even if the audio volume is off.

1.3.1.5 **TOUCHPAD KEY LOCK**

Disables touchpad to prevent tampering.

1.3.1.6 **TOUCHPADS**

Use to access setup and in programming. Function of touchpad depends upon key lock and user access setting. (See section 3.1)

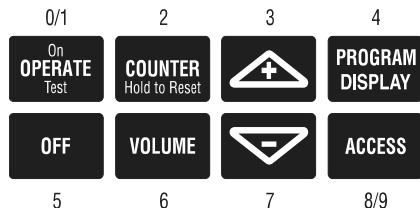

FIGURE 1-2

1.3.1.6.1 **OPERATE (ON / SELF-TEST)**

The OPERATE touchpad is used to turn the PD 6500i on. The unit will be ready to operate within ten seconds. Activate the manual self-test at any time by pressing OPERATE.

1.3.1.6.2 **OFF**

The OFF touchpad is used to turn the PD 6500i off, ensuring that all of the information and settings are stored in memory until the detector is ready to resume full operation.



1.3.1.6.3 **COUNTER**

The COUNTER touchpad is used to obtain an automatic update on the traffic count that appears on the LCD. The counter also reports alarm statistics such as alarm count and alarm count %.

If operator access is enabled, the counter may be reset by pressing the COUNTER touchpad for approximately ten seconds.

1.3.1.6.4 **VOLUME**

The VOLUME touchpad is used to access the volume control of the audio alarm.

- 1.3.1.6.5** (+) and (-)
The plus (+) and minus (-) touchpads are used to change numerical settings, activate certain on/off functions and adjust the volume of the audio alarm.
- 1.3.1.6.6** PROGRAM DISPLAY
The PROGRAM DISPLAY touchpad enables the user to view the program and base sensitivity settings on the LCD.
- 1.3.1.6.7** ACCESS
The ACCESS touchpad is used to initiate log in process and to scroll through menu items.
- 1.3.1.7** **PINPOINT LIGHTS**
Pinpoint lights are located on the exit side of each panel and provide information about 11 horizontal and 3 vertical positions for a total of 33 pinpoint areas. These lights help the operator to identify the precise location of a metal object within the walk-through, whether it is on the left, right or in the center of the body, from head to toe. (See Figure 1-3)
- 1.3.1.8** **PACING LIGHTS**
Pacing lights located on side panels of the entrance side indicate whether or not a patron may enter the walk-through. The green "proceed" () symbol indicates the unit is ready for a patron, while the red "wait" () symbol indicates the patron should wait. (See Figure 1-3)

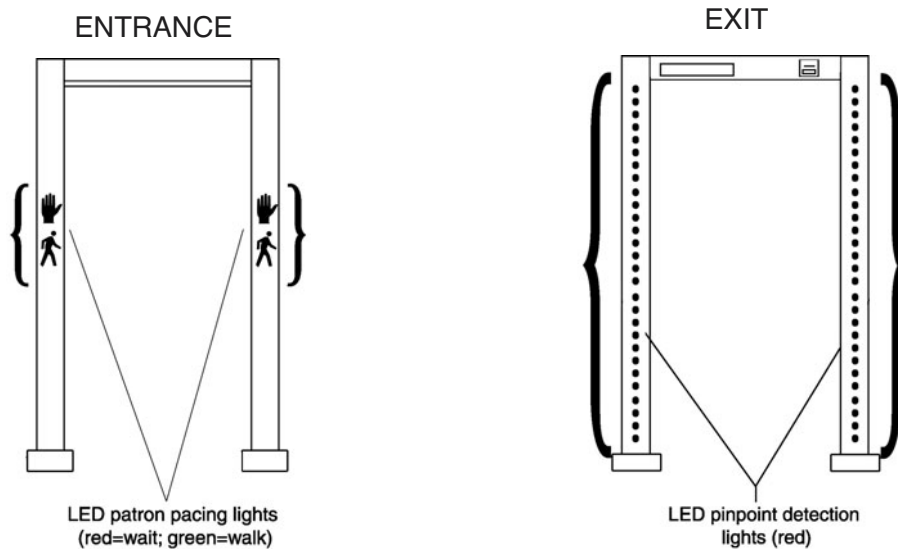

FIGURE 1-3

1.3.2 DESCRIPTION OF AUDIO RESPONSES

1.3.2.1 TARGET ALARMS

The steady single pitch audio alarm indicates that a target has been identified according to the program and sensitivity settings.

1.3.2.2 WARBLE ALARM

A quickly alternating two-tone alarm occurs when a large metal object, such as a wheelchair, piece of furniture, or metal container, moves through or near the PD 6500i and overloads the detector's circuits. The warble sound prompts the operator to correct the situation before allowing anyone to pass through the metal detector.

1.3.2.3 TAMPER ALARM

When the ACCESS touchpad is pressed, the detector beeps for about ten seconds until a valid user is selected and a numeric access code is entered. If a person or object passes through the archway during this time, a loud low-toned alarm will activate. If an invalid code is entered, the message: ACCESS DENIED appears on the LCD, and the same audible tamper alarm sounds and normal operation resumes. The tamper alarm may be set to block access after three unsuccessful attempts have been made for a user. The entry of an access code for next level of security is required in order for operation to resume.

Each access attempt is indicated by an increase in the sequence code as reported on the LCD. Any unauthorized access attempt that activates the tamper alarm is indicated by an asterisk (*) which remains until the system is successfully accessed.

2. INSTALLATION

2.1 SITE SELECTION & REQUIREMENTS

Before choosing a site for the PD 6500i Walk-Through Metal Detector, it is important to consider the volume and throughput requirements of patron traffic, space availability and overall environmental conditions. In all cases, the PD 6500i must be installed on a level, stable floor. The following site requirements are provided as guidelines to a successful installation.

Garrett Metal Detectors (Garrett) has years of experience designing, installing and operating security screening checkpoints. Garrett's experience ranges from very small, one and two detector checkpoints, to very large, 900 detector Olympic operations. Garrett always prefers to work closely with its clients when designing checkpoints. Every client has a unique situation and needs a somewhat customized solution. Garrett is happy to assist in designing and implementing these solutions. This section is intended to provide general information for designing security screening checkpoints.

2.1.1

ELECTRICAL POWER

Electricity is a critical element for successful, trouble free, installations. Garrett metal detectors require 100-240 Volt, 50/60 Hertz power, and draw less than 1 ampere each. Consequently, "power load" is minimal for any group of detectors. Garrett detectors operate using an innovative "pulse induction" technology.

This technology demands that all detectors within 25' to 100' of each other depending on sensitivity setting, be connected to the same single phase, single source of power.

This can be easily accomplished using power cords if existing power does not, or cannot, meet this requirement.

Garrett metal detectors are very versatile and can be connected to power from either their top or bottom of either side. This makes connecting power very convenient and gives the user more options when designing their sites. When "running" power along the ground it is recommended that cords be secured to the ground using highly visible industrial tape or cable trays. This ensures that the cord is visible to patron traffic and prevents personal injury as well as equipment damage. When "running" power overhead it is recommended that power cords be suspended above the detector. This keeps the cord accessible for maintenance, but out of reach of regular traffic.

2.1.2

PHYSICAL SITE

Appropriate selection and preparation of a site is paramount for successful, efficient and effective checkpoint screening operations. The site should be flat, level and free from obstructions. The surface should be solid and free from any vibration or movement. Most indoor surfaces are already adequate. Outdoor surfaces should be asphalt or concrete, wooden platforms can NOT be used. The site should be free from running or standing water and should provide protection from weather elements. An industrial, four-walled tent is the best way to provide shelter from the weather elements when outdoors. The tent must be strong enough to repel rain, snow, sleet and a fair amount of wind.

2.1.3

SPACING AND CONFIGURATION

A site must also allow for efficient spacing and configuration of metal detectors. If a site is too small the operation of the checkpoint becomes "choked" and "bottlenecks" form. This severely hampers the flow of "traffic" through a checkpoint and can be troublesome when trying to operate within time constraints. If a site is too big it becomes difficult to oversee the checkpoint, and valuable space is wasted. As a general rule a rectangular block of space 8' wide and at least 10' deep should be reserved for every detector. There are many ways to arrange detectors at a checkpoint; Garrett has found two configurations, which work the best. Please refer to the attached drawings.

LEGEND

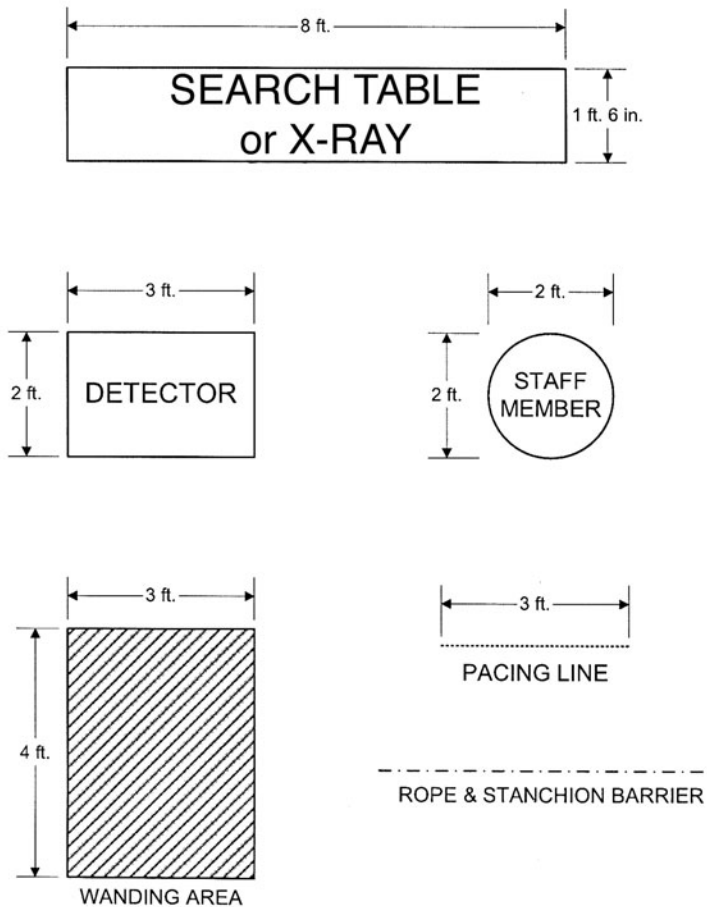

SINGLE LINE CONFIGURATION

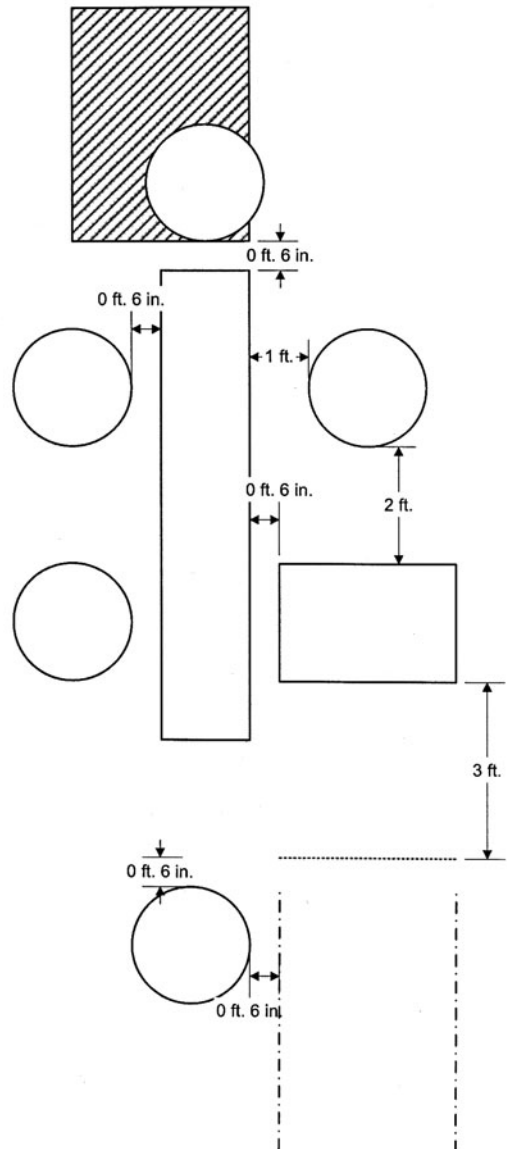

ONE LINE CONFIGURATION (40'x20' TENT)

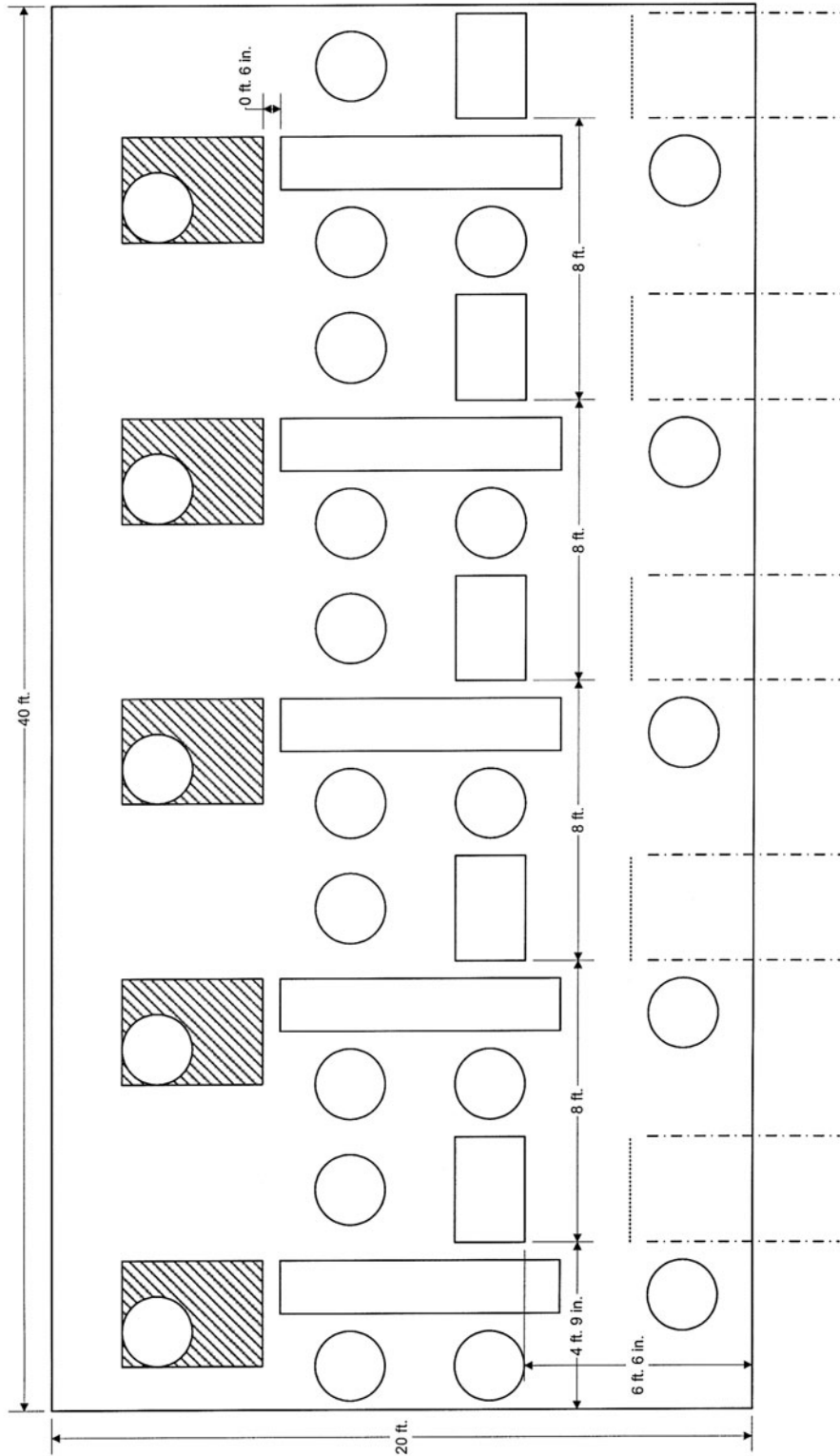

TWO LINE CONFIGURATION (40'x40' TENT)

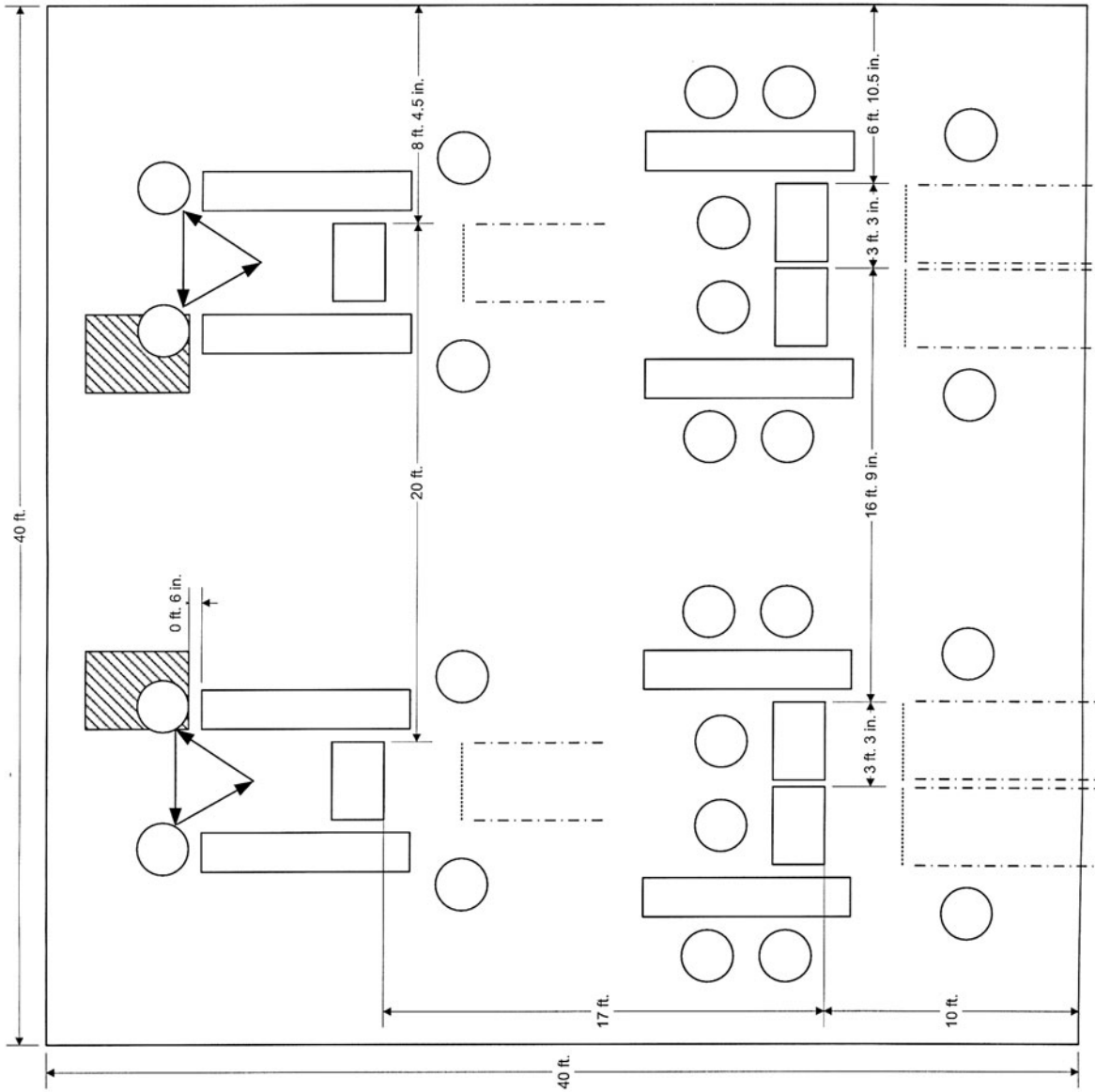

2.1.4

INTERFERENCE

Many variables can potentially cause interference with any metal detector operation. However, there are some major variables to address. Electrical sources of interference, generators, transformers, electrical panels, etc., should be kept as far away as possible. Large metallic objects moving or stationary, revolving doors, elevators, garbage cans, barricades, etc., should be kept as far away as possible. Search tables and personnel should be placed a minimum of 6" from the detector. X-Ray machines and other complementary screening equipment should be placed a minimum distance of 12" from the detector.

2.2

UNIT ASSEMBLY

The enclosed instructional video provides detailed assembly instructions.

1. Verify that the following contents are included:

- Panel "A"
- Panel "B"
- Detection Unit (Head)
- Crosspiece (Support Brace)
- 2' AC Jumper Cord
- 10' Power Cord
- Eight 1/4-20x3" Screws
- Eight Finishing Washers
- User Manual

Accessories:

- Instruction Video
- Pocket Item Container (Coin Tray)
- Stabilizing Plates (Optional)

2. Arrange the major components as shown in Figure 2-1.

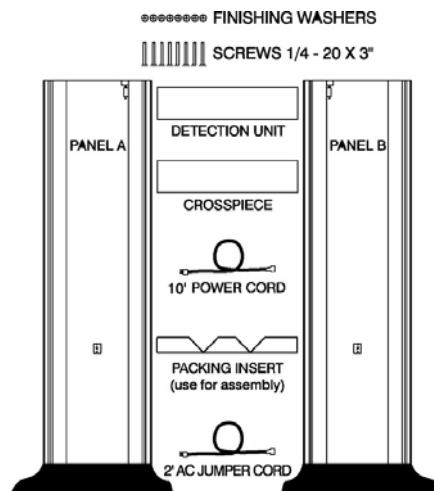

FIGURE 2-1

**GARRETT PD 6500i
USER MANUAL**

3. Place any one of six packing inserts on floor as shown in Figure 2-2. Lay detection unit (with touchpad panel facing down) on packing insert. Connect detection unit to panels A and B using four screws and finishing washers. Do not tighten!

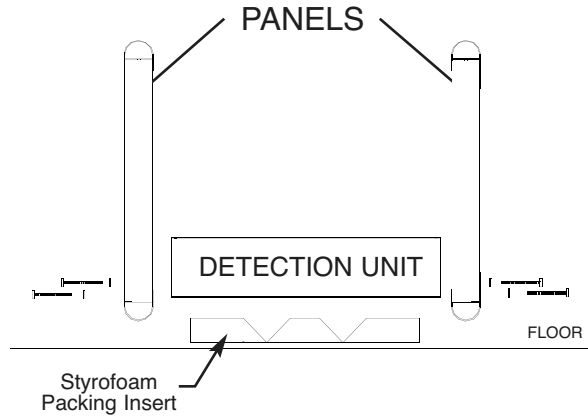

FIGURE 2-2

4. Open the door of the detection unit. Select a panel for power use (keeping in mind the location of the electrical outlet) and connect the AC jumper cord to the selected panel and the power module. Then, connect cables A and B to the corresponding panels. (See Figure 2-3)

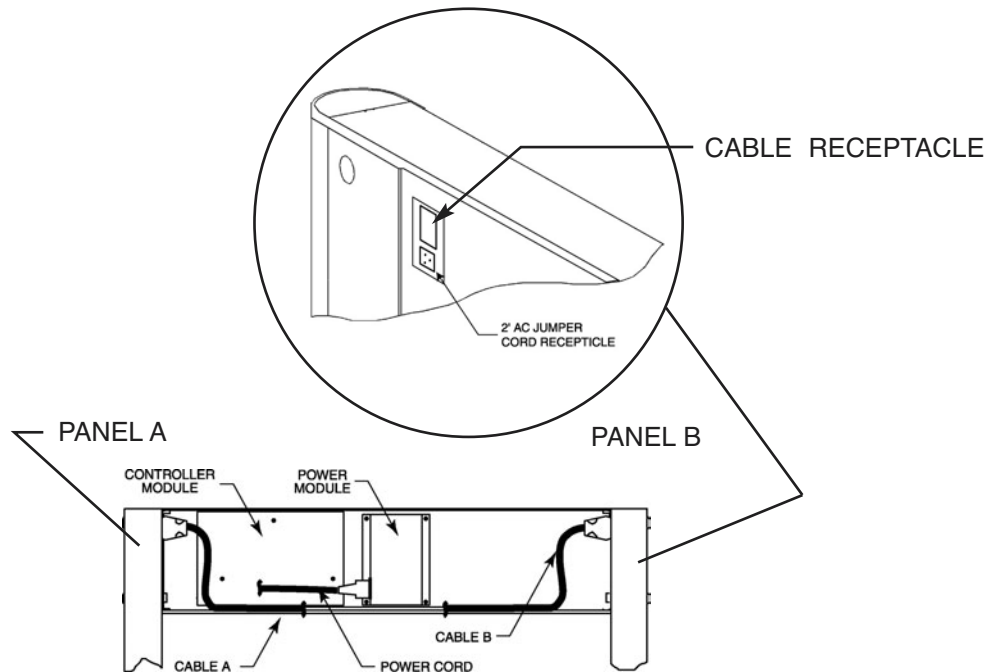

FIGURE 2-3

5. Remove power cord from the base of the panel to which the AC jumper cord has been connected. (Cord is located under the foot of the “entrance” side of the panel. Once cord is pulled out, slide it under the outside wall of panel so cord clears boot when unit is set back down.) If power is to be supplied from the top, remove the access plug in the top of the detection unit.

6. Use the four remaining screws and washers to attach the crosspiece to the two panels as shown in Figure 2-4.

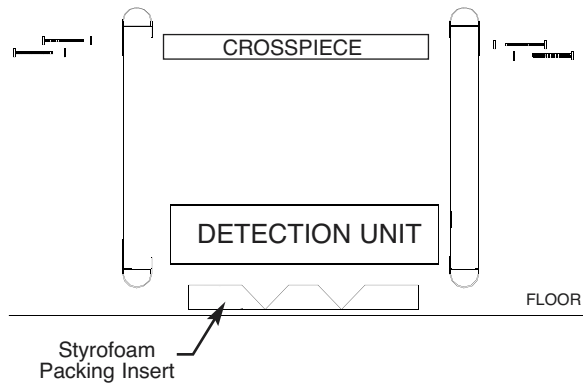

FIGURE 2-4

7. If optional stabilizer mounts are to be used, attach stabilizer plates to side panels. Do not remove adhesive protectors at this time.

8. Use two or more people to lift PD 6500i to a vertical position and move to desired location. (See Figure 2-5)

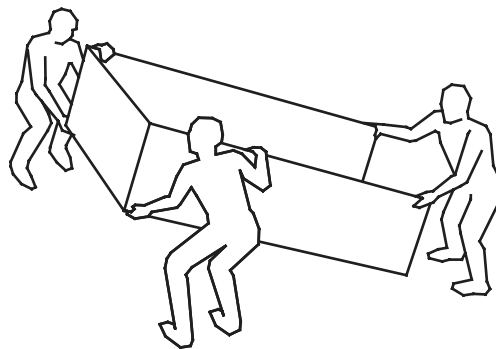

FIGURE 2-5

9. Ensure the PD 6500i is physically stable and does not sit on top of power cord.

10. Tighten all screws with a screwdriver.

2.2.1 POWER CORD WIRING DESCRIPTION

The PD 6500i (Model 11684xx) includes a standard American ground power cord. To replace or remove plug, or to hard wire to an AC junction box, use:

Green	To Ground
Black	To line Hot
White	To line Neutral

The PD 6500i (Model 1168420) (INTERNATIONAL) includes a European power cord. To replace or remove plug, or to hard wire to an AC junction box, use:

Green/Yellow	To Ground
Brown	To line Hot
Blue	To line Neutral

2.2.2 STABILIZING

For proper stability, the PD 6500i should be firmly secured to the ground. Anchor the unit to the floor, using the 1/4" mounting holes located at the base of each panel. Position the PD 6500i in the desired location. Using the panels as guides, mark and drill holes, then secure the walk-through using the appropriate mounting devices. Tighten only to prevent rocking. DO NOT over-tighten! As an option, stabilizer bases or adhesive floor mounting plates are available for securing the PD 6500i to the floor without drilling.

2.3 PLACEMENT PROCEDURE

1. Place assembled unit (For Assembly, See Section 2.2) in final position at checkpoint location.
2. Connect to power source.
3. Program / Calibrate unit. (See Section 3)
4. Check for interference and troubleshoot. (See Section 5)
5. Test. (See Section 2.3.1 and 2.3.2)

CAUTION

For multiple PD 6500i operation (units within 25' to 100' of each other depending on sensitivity setting), additional power requirements and installation adjustments are necessary to avoid crosstalk (interference) among units. (See sections 2.1.3 and 2.4 for multiple unit operation)

2.3.1 OPERATIONAL TESTING

Once the PD 6500i is calibrated, a SELECTED TEST OBJECT can be used as a substitute for the forbidden object in subsequent routine verifications. A SELECTED TEST OBJECT is an object similar in size, shape and material composition to the smallest forbidden target and is considered an acceptable means of verifying calibration.

Garrett offers an optional **SELECTED TEST OBJECT** that meets the specifications of the U.S. Federal Aviation Administration (FAA) (Garrett Accessory #1600600), and represents a small firearm.

Each installation requires a carefully selected calibration test object.

2.3.2 FUNCTIONAL TEST

A standard, functional test is essential in order to ensure that the PD 6500i is always calibrated and functioning properly. The test should complement your overall security plan and be performed daily. Pass a **SELECTED TEST OBJECT** and/or other objects at varying locations and orientations within the archway. Note the number of repetitions that you need to trigger successful alarms.

Whoever performs the routine test must be free of metallic items, including shoes with steel toes or shanks prior to testing. A hand-held metal detector can be used to confirm that the tester is “metal free”.

2.4 MULTIPLE WALK-THROUGH SITE INSTALLATION SETUP

Each PD 6500i must be free from interference from adjoining walk-through metal detectors. To ensure that there is no interference, observe the bar graph of one walk-through while switching the remaining walk-through(s) from OFF to OPERATE. If interference is indicated on the walk-through's bar graph when remaining unit(s) are in the operate mode, and no interference takes place with remaining units off, crosstalk is occurring.

There are several ways to successfully install multiple walk-throughs in close proximity with no crosstalk. The following examples are aimed to help the installer determine an appropriate method.

2.4.1 CASE 1

Description:

- Two or more PD 6500i 's that interfere with each other.
- All units within 25' to 100' of each other depending on sensitivity settings must be plugged into the same AC power line (same circuit breaker).
- Do not place more than two units within any 10' span.

Procedure:

1. Set all PD 6500i's synchronization MASTER.
2. Set end unit (i.e., first or last in a series of PD 6500i's) to CHANNEL 1.
3. Set next unit to CHANNEL 2.
4. Set next unit to CHANNEL 1.
5. Repeat pattern for channels 1 and 2 for any additional PD 6500i's.

2.4.2

CASE 2:

Description:

- Two or more PD 6500i's that interfere with each other.
- PD 6500i's not plugged into the same AC power line or those with battery back-up option which may be required to operate in the absence of AC power.

Procedure:

1. Disconnect PD 6500i's from power line.
2. Open access door of detection unit.
3. Remove the three screws that hold controller cover. (See Figure 2-6)
4. Use synchronization wire (18 to 24-gauge, 2 conductor) between units; connect as shown. (See Figure 2-7) (Connector block is a plug in and may be removed to facilitate connection of unit)
5. With the exception of the end units, the SH1 jumper, located on the controller board assembly must be removed. (See Figure 2-7)
6. Replace covers and reconnect power.
7. Set the end unit (i.e., first or last in a series of PD 6500i's) synchronization to MASTER CHANNEL 1 and make sure it is always connected to either AC power or battery power.
8. Set all other units synchronize to SLAVE.
9. Set the remaining units to CHANNEL 2 and 1 as shown in Figure 2-7.
10. Repeat pattern of channels 1 and 2 for any additional PD 6500i's.

2.4.3

OPERATING WITH GARRETT PRODUCTS OTHER THAN PD6500i

The PD6500i will operate with other Garrett walk-through metal detectors with some limitation. As a general rule the installation described in sections 2.4.1 and 2.4.2 apply with the exception that the alternating channels selected should be Channel A and Channel B. Channels C & D of other Garrett Products should not be used when operating with the PD6500i. Spacing requirements may vary and may be dependent on program and sensitivity settings.

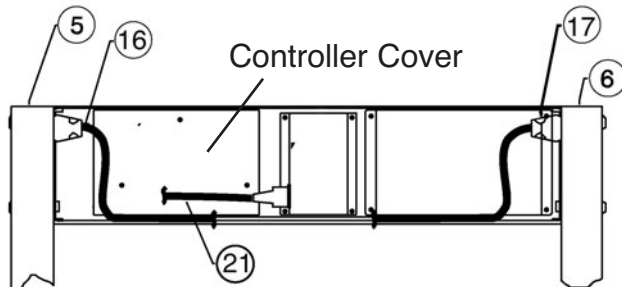

FIGURE 2-6

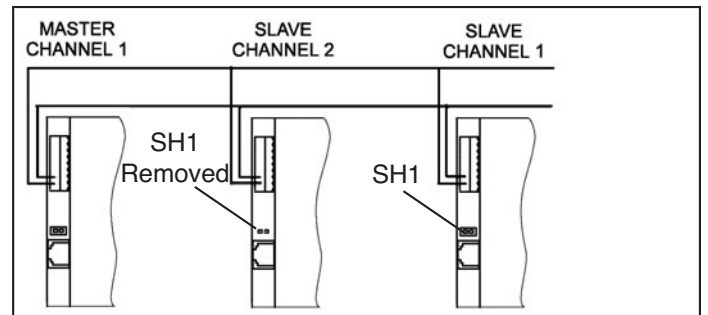

FIGURE 2-7

(See table 5-3 for parts list)

3. MENUS

There are three access levels of security clearance (Operator, Supervisor and Administrator) for the PD 6500i.

Operator: This access level has the ability to view and alter authorized Monitor Functions (see Table 3.1) of the walk-through. These Monitor Functions may be viewed by the Operator without a user login. (The Administrator, however, has the authority to turn these Monitor Functions “ON” or “OFF” for the operator).

Supervisor: This access level requires a user login code and may require a key to view and alter authorized functions in the menu (see Table 3.1).

Administrator: This level user has access to all functions. This level requires a user login and may require a key (see Table 3.1).

**GARRETT PD 6500i
USER MANUAL**

3.1.

MENU TABLE

The following table lists access levels and menu functions.

TABLE 3.1

	Function	Operator*	Supervisor	Administrator
	Default Access Code	Not Required	1234	5678
	Power	Off / On	Off / On	Off / On
	Self Test	View**	View	View
Monitor	Program	View**	-	-
	Base Sensitivity	View**	-	-
	Volume	0-12**	0-12	0-12
	Patron Count	View**	View	View
	Alarm Count	View**	View	View
	Alarm %	View**	View	View
	Sequence	View**	View	View
	Reset Counters	Yes**	Yes	Yes
Preferences	Tone	-	-	1-9
	Pacing Lights	-	-	On / Off
	Zone Lights	-	-	Off, 2, 3, 4, Sec
	Alarm Time	-	-	1, 2, 3, 4, Sec
	I / R Analysis	-	On / Off	On / Off
	Language	-	-	E, S, G, T
Programming	Rx Balance	-	-	View
	Synchronization	-	-	M / S
	Channel	-	-	1, 2, A, B
	Program	-	Select	Select
	Base Sensitivity	-	1-200	1-200
	Alarm Level	-	View/Reset	View / Reset
	Zone 1 Boost	-	-	+/- 15%
	Zone 2 Boost	-	-	+/- 15%
	Zone 3 Boost	-	-	+/- 15%
	Zone 4 Boost	-	-	+/- 15%
	Zone 5 Boost	-	-	-63 - +192%
	Zone 6 Boost	-	-	-63 - +192%
	Relay	-	-	NO / NC
Administration	Operator Enable	-	-	Off / On W-lock / On
	Alter Code 1	-	-	Yes
	Alter Code 2	-	-	Yes

* Items in Operator column are only accessible when Operator Enable is in "ON" position

** With touchpad

3.2

POWER ON / OFF

When you press the OPERATE touchpad for the first time, the READY light appears and the LCD displays the message, GARRETT SECURITY. Press OPERATE again, and the unit will begin its first self-test. The LCD will display the following information, in sequence:

LCD MESSAGE	DEFINITION
<ol style="list-style-type: none"> 1. S/N #####* 2. VERSION ### 3. 60 or 50 Hz 4. SYNC MASTER or SLAVE 5. CHANNEL 1 or 2 6. PROG: XXXXXXXX 7. BASE SENSE: ### 8. SELF-TEST... 9. BATT POWER XX% 10. SELF TEST OK 11. OPERATE 	<p>serial number software version line frequency synchronization channel selection program selection base sensitivity setting self test in progress strength of battery if in use self test reveals no problems resume operate mode</p>

3.3

SELF TEST

Every time the PD 6500i is turned on, a self-test occurs. To safeguard against non-critical failures, after unit is initially turned on, user should perform a manual self-test by pressing the self-test touchpad again. The unit will initiate a self-test that will report the results on the LCD screen. Should the self-test reveal a problem, a "failure" message will appear (e.g., SYNC FAIL). (Refer to Table 5.4 for a list of possible failures and remedies). The self-test feature within the unit is in constant operation and will reveal "critical failures" instantaneously. If unit is in 24 hour, 7-day a week operation, a manual self-test should be conducted at least once every 24 hour period to check for non-critical failures. The operator should inform the supervisor about any problems that appear on the LCD.

3.4

USER ACCESS

To log in, the user must press the "ACCESS" touchpad. The unit will prompt the user to enter their password.

3.5

MENU ITEMS

Each user may scroll through the menu items assigned to their particular level. Some menu items are available as "view only". The PD 6500i will not allow this user to change any of the "view only" items. To scroll the menu items, use the ACCESS touchpad; to scroll in the reverse order, press PROGRAM touchpad.

3.5.1

PROGRAM

PROG: <current program set>, will appear on LCD. If user is authorized to change the program, the user may scroll the menu of programs using the + / - touchpads to find the new program. Stop scrolling when program desired appears on LCD. (Refer to Table 4.2 for a listing and description of programs)

Press ACCESS for the next adjustment or OPERATE to resume normal operation.

3.5.2

BASE SENSITIVITY

At higher sensitivity settings, smaller metal objects are detected. Conversely, at lower sensitivity settings, only larger metal objects are detected. Keep in mind that the sensitivity should be set high enough so that the smallest forbidden object (depending on your security needs) can be detected.

BASE SENSE: <current base sensitivity setting>, will appear on LCD. If user is authorized to change the base sensitivity, the user may scroll from 1-200 using the + / - touchpads. To determine proper sensitivity setting, follow ALARM LEVEL setting instructions in section 3.5.18.

SPECIAL NOTE

A final decision on program and base sensitivity settings is the sole responsibility of the end user and must be determined by keeping the intent of the security application.

Press ACCESS for the next adjustment or OPERATE to resume normal operation.

3.5.3

ADJUST VOLUME

VOLUME <current volume setting>, appears on LCD. The user may use the + / - touchpads to increase or decrease the alarm volume from 0 - 12.

Press ACCESS for the next adjustment or OPERATE to resume normal operation.

3.5.4

PATRON COUNTER

A built-in and user resettable traffic counter records the number of patrons who pass through the walk-through. This is a "view only" menu item. To reset the counter to zero, refer to section 3.5.8.

COUNT <number of patrons who have passed through the detector>.

Press ACCESS for the next menu item or OPERATE to resume normal operation.

3.5.5

ALARM COUNT

A built-in and user resettable alarm counter records the number of alarms that have occurred. This is a "view only" menu item. The alarm count is automatically reset to zero when the patron counter is reset.

Press ACCESS for the next menu item or OPERATE to resume normal operation.

3.5.6

ALARM COUNT %

A built-in and user resettable alarm count % calculates the percentage of alarms to patrons. This is a "view only" menu item. The alarm count % is automatically reset to zero when the patron counter is reset.

Press ACCESS for the next menu item or OPERATE to resume normal operation.

3.5.7

SEQUENCE

SEQUENCE <number of times the system has been successfully accessed via password>. This is a "view only" menu item.

Press ACCESS for the next menu item or OPERATE to resume normal operation.

3.5.8

RESET COUNTER

RESET COUNT will appear on LCD. For Operator Access Level user to reset counter, the Administrator must have the Operator Enable set to "ON" position. Supervisor and Administrator Access level personnel may also reset counter by logging on with their own personal user login code.

To reset counter, press the + touchpad for approximately 10 seconds. The patron count, alarm count and alarm count % will all reset to zero.

Press ACCESS for the next adjustment or OPERATE to resume normal operation.

3.5.9



ADJUST TONE

TONE <current tone setting>, appears on LCD. If user is authorized to adjust the tone, the user may use the + / - touchpads to adjust the tone from 1 (low bass) to 9 (high treble).

Press ACCESS for next adjustment or OPERATE to resume normal operation.

3.5.10

PACING LIGHTS

Pacing lights located on the side panels of the entrance side indicate whether or not a patron may enter the walk-through. The green proceed symbol () indicates proceed and the red wait symbol () indicates wait.

PACE LIGHTS <ON / OFF>, appears on LCD. If user is authorized to change the pacing lights, the user may use the + (pacing lights on) / - (pacing lights off) touchpads to set pacing lights.

Press ACCESS for the next adjustment or OPERATE to resume normal operation.

3.5.11 ZONE LIGHTS

The zone light duration may be adjusted to two, three, or four seconds, or turned off.

Zn LIGHTS: <2-sec (default)>, will appear on LCD. If user is authorized to change zone light duration, the user may press the + / - touchpads to scroll through the options:

ZONE LIGHT: OFF
ZONE LIGHT: 2 SEC
ZONE LIGHT: 3 SEC
ZONE LIGHT: 4 SEC.

Press ACCESS for the next adjustment or OPERATE to resume normal operation.

3.5.12 ALARM TIME

Sets the duration for audible alarms for 1, 2, 3 or 4 seconds.

ALARM TIME: <1-SEC> (default), will appear on LCD. If user is authorized to change alarm time, the user may use the + / - touchpads to adjust the time between 1-SEC to 4-SEC in 1 second increments.

Press ACCESS for the next adjustment or OPERATE to resume normal operation.

3.5.13 IR ANALYSIS

An infrared sensor has been designed to help prevent false alarms indoors caused by nearby moving metallic materials such as wheelchairs, elevators, persons possessing metal, etc., and outdoors by wind causing the unit to rock and then alarm. When IR Analysis is on, the above circumstances will not cause the detector to audibly alarm when no one is passing through the unit. When IR Analysis is off, the unit may audibly alarm under these circumstances even when no one is passing through the unit. By switching the IR Analysis on, the infrared system will improve the analysis of the detection signal, increase traffic flow and help prevent false alarms. Although useful, the IR Analysis is not required for operation and may be disabled if desired.

IR ANALYSIS <on>, will appear on LCD. Press the minus (-) touchpad to disable or (+) touchpad to activate.

Press ACCESS for the next adjustment or OPERATE to resume normal operation.

3.5.14

LANGUAGE

LANGUAGE <current language setting>, appears on the LCD. If the user is authorized to change the language setting, the user may scroll through the language selections using the + / - touchpads. Choose from:

LCD MESSAGE	LANGUAGE
LANGUAGE ENGLISH	ENGLISH
IDIOMA ESPANOL	SPANISH
DIL TURKCE	TURKISH
SPACHA DEUTSCH	GERMAN

Press ACCESS for the next adjustment or OPERATE to resume normal operation.

3.5.15

RX BALANCE

RX BAL < RX balance number >, appears on LCD. RX balance refers to the balance level of the receiving antennas. Any number less than 50 is acceptable. A number greater than 50 will elicit the message, RX BAL #, and the pinpoint lights within the problem zone will illuminate. Should this occur, ensure that there is no large metal object adjacent to the PD 6500i. Then, ensure that the balance number has fallen below 50 and the corresponding pinpoint lights are off. (Refer to section 5.4 for more help in resolving this issue if necessary)

Press ACCESS for the next adjustment or OPERATE to resume normal operation.

3.5.16

SYNCHRONIZATION

Synchronization is factory preset to MASTER. Refer to Section 2.4 for a more detailed explanation of synchronization.

SYNC MASTER, provides the PD 6500i with a self-generated synchronization from the power line.

SYNC SLAVE, synchronizes the PD 6500i from a second signal on the sync terminal located on the left edge of the transmitter controller board.

SYNC <MASTER or SLAVE>, will appear on LCD. If user is authorized to change synchronization, the user may use the + / - touchpads to change sync to MASTER or SLAVE.

Press ACCESS for the next adjustment or OPERATE to resume normal operation.

3.5.17

CHANNEL

This feature enables multiple walk-through metal detectors to operate simultaneously in proximity. Use Channels 1 and 2 when two or more PD 6500i's are operating near each other. (See Section 2.4)

CHANNEL <1 or 2>, will appear on LCD. If user is authorized to change channels, the user may use the + / - touchpads to change channel to 1 or 2.

Press ACCESS for the next adjustment or OPERATE to resume normal operation.

CAUTION! When using any other Garrett walk-through metal detectors with PD 6500i's, use channels A and B to coincide with other Garrett walk-through channels A and B.

3.5.18

ALARM LEVEL

Alarm level is a tool that helps you determine the lowest level of sensitivity required to activate an alarm for a particular metal object. This information can then be used to determine the desired level of sensitivity.

ALARM LEVEL <current alarm level setting>, will appear on LCD. The following is an example of the use of alarm level.

1. Note the alarm level that appears (e.g., ALARM LEVEL: 123).
2. Press the + (plus) touchpad.
3. Ensure that you are metal free.
4. Hold the selected test object or place it on your person.
5. Walk through the metal detector.
6. Note the new alarm level reading.
7. Change the test object's location and/or orientation.
8. Repeat steps two through seven several times until you are satisfied that you've performed enough tests.
9. Choose the highest reading that detected the test object.
10. Return to the base sensitivity menu item and enter the alarm level reading that you chose in Step 9 as the base sensitivity. To confirm that the new base sensitivity setting is appropriate, test the selected test object at varying locations and orientations within the

walk-through (alarms should occur with each pass), particularly in locations and orientations where you suspect detection is most difficult. Alarms will occur if sensitivity setting is correct.

After choosing the base sensitivity, press **ACCESS** to make another adjustment or **OPERATE** to resume normal operation.

3.5.19

ZONE 1-4 (ZONE 1=150+0%)

Adjusting the sensitivity of the six horizontal zones helps establish an optimal detection field. Each zone adjustment is based on a percentage of the base sensitivity. The top to bottom horizontal zones and their corresponding pinpoint lights are referred as zones one to six.

The sensitivity of the first four zones can be adjusted from -15% to +15% of the base sensitivity. For example an adjustment of zero percent means that the sensitivity of a given zone is equal to the base sensitivity.

ZONE 1 = <current base sensitivity number setting> + <choice of -15% to +15%>, will appear on LCD. If user is authorized to change this setting, the user may use the + (to increase) or - (to decrease), in 1% increments, the percent to be increased or decreased from the base sensitivity level.

The following are a few examples of adjustments based on a base sensitivity setting of 150.

ZONE 1= 150+0% (Zone 1 is set to the base sensitivity)

ZONE 1= 150+15% (Zone 1 sensitivity is 15% greater than the base sensitivity)

ZONE 1= 150-15% (Zone 1 sensitivity is 15% less than the base sensitivity)

ZONE 2 = <current base sensitivity number setting> + <choice of -15% to +15%>, will appear on LCD. If user is authorized to change this setting, the user may use the + (to increase) or - (to decrease), in 1% increments, the percent to be increased or decreased from the base sensitivity level.

ZONE 3 = <current base sensitivity number setting> + <choice of -15% to +15%>, will appear on LCD. If user is authorized to change this setting, the user may use the + (to increase) or - (to decrease), in 1% increments, the percent to be increased or decreased from the base sensitivity level.

ZONE 4 = <current base sensitivity number setting> + <choice of -15% to +15%>, will appear on LCD. If user is authorized to change this setting, the user may use the + (to increase) or - (to decrease), in 1% increments, the percent to be increased or decreased from the base sensitivity level.

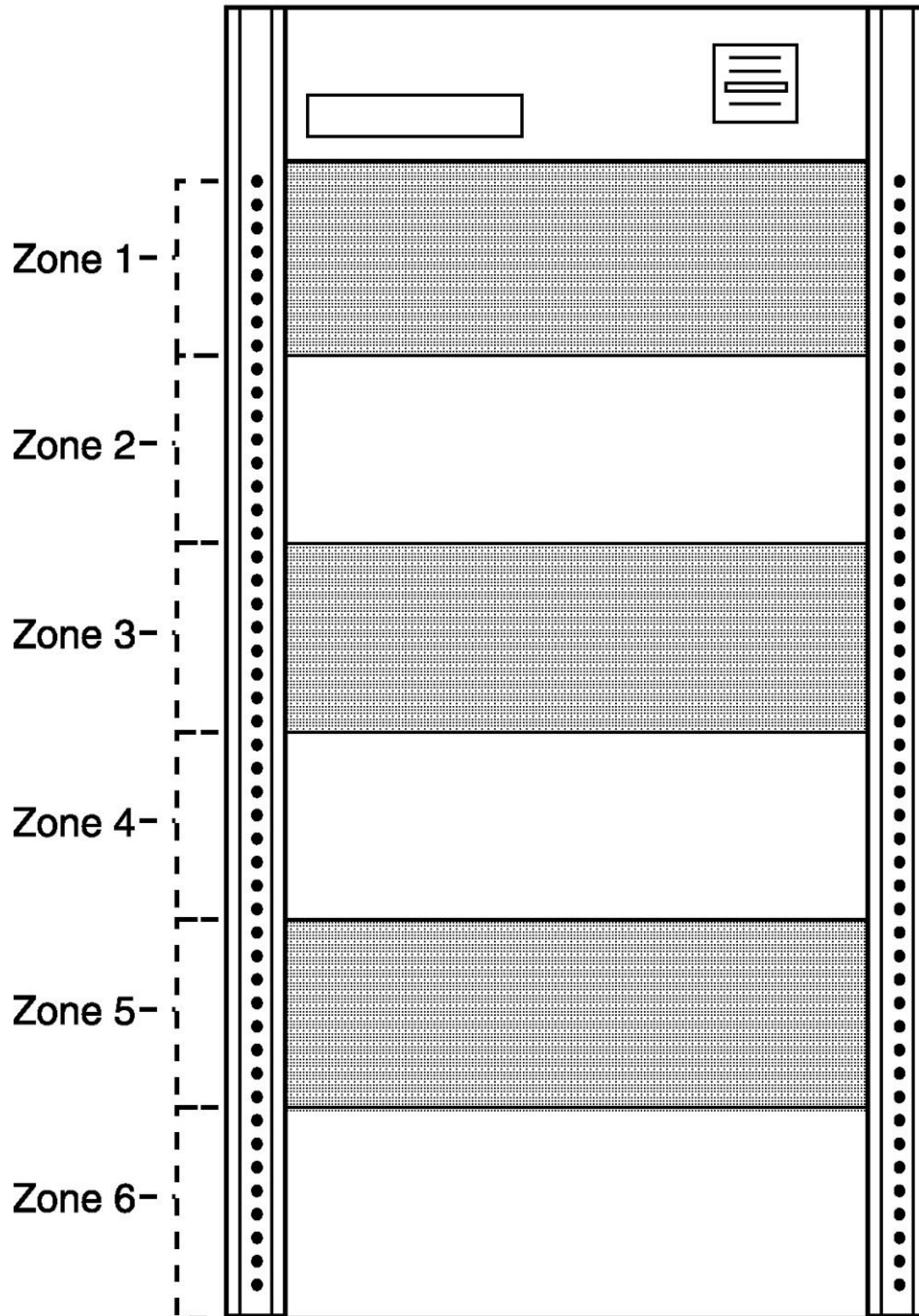

FIGURE 3-1

ZONE 5-6 (ZONE 5=150+0%)

The sensitivity of the last two zones can be adjusted from -63% to +192% of the base sensitivity. For example an adjustment of zero percent means that the sensitivity of a given zone is equal to the base sensitivity.

The following are a few examples of adjustments based on a base sensitivity setting of 150.

ZONE 5= 150+0% (Zone 5 is set to the base sensitivity)

ZONE 5= 150+192% (Zone 5 sensitivity is 192% greater than the base sensitivity)

ZONE 5= 150-63% (Zone 5 sensitivity is 63% less than the base sensitivity)

ZONE 5 = <current base sensitivity number setting> + <choice of -63% to +192%>, will appear on LCD. If user is authorized to change this setting, the user may use the + (to increase) or - (to decrease), in 1% increments, the percent to be increased or decreased from the base sensitivity level.

ZONE 6 = <current base sensitivity number setting> + <choice of -63% to +192%>, will appear on LCD. If user is authorized to change this setting, the user may use the + (to increase) or - (to decrease), in 1% increments, the percent to be increased or decreased from the base sensitivity level.

Press ACCESS for the next zone adjustment or OPERATE to resume normal operation.

3.5.20

RELAY

This feature enables user to change the AC and DC relay circuits to "normally open" (RELAY N/O) or "normally closed" (RELAY N/C) depending on the installation requirements. RELAY <N/O or N/C>, will appear on LCD. If user is authorized to change relay, the user may use the + / - touchpads to change to N/O or N/C.

Press ACCESS for next adjustment or OPERATE to resume normal operation.

3.5.21

ALTER SUPERVISOR CODE (+ TO ALTER CODE 1)

The Supervisor Adjustments code (referred to as CODE1) is factory preset to 1234. To change it:

1. Press the + touchpad.
2. Enter a new four-digit code.
3. When the LCD prompts, REPEAT CODE, re-enter the new four-digit code. The message, CODE ENTERED OK, should appear. (If the message, INVALID ENTRY, appears, repeat steps 2 and 3.)

Press ACCESS for the next adjustment or OPERATE to resume normal operation.

3.5.22

ALTER ADMINISTRATOR CODE (+ TO ALTER CODE 2)

The Administrator Adjustments code (referred to as CODE2) is factory preset to 5678. To change it:

1. Press the + touchpad.
2. Enter a new four-digit code.
3. When the LCD prompts, REPEAT CODE, re-enter the new four-digit code. The message, CODE ENTERED OK, should appear. (If the message, INVALID ENTRY, appears, repeat steps 2 and 3.)

Press ACCESS for the next adjustment or OPERATE to resume normal operation.

3.6

CODE RESET

Should the administrator access code be forgotten or misplaced, the PD 6500i has a mechanical method for resetting the administrator access code to factory preset code.

1. Open the main cover of the detection unit.
2. Remove the three screws attached to the controller module cover.
3. With power turned on and the unit in Operate mode, press and hold the ACCESS CODE RESET button (on the upper left side of the lower circuit board) for ten seconds. (See Figure 3-2)

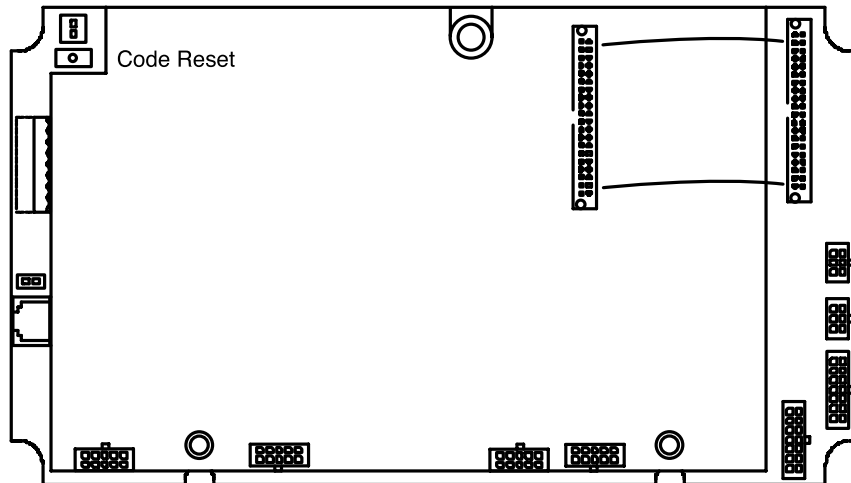

FIGURE 3-2

4. PROGRAMS
The PD 6500i offers several programs designed to help meet specific security needs.

TABLE 4.2

<u>PROGRAM</u>	<u>DESCRIPTION / USE(S)</u>
Airports Schools Courthouses Buildings Special Events	Designed primarily for detection of guns and other such weapons. Exceeds FAA detection requirements (i.e. FAA 3-gun test). Provides excellent discrimination against innocuous items such as coins, keys, jewelry, shoe-shanks, cigarette packs, foil, etc. Recommended for applications requiring general weapons detection while providing high traffic throughput with minimal nuisance alarms.
Airports Enhanced Nuclear	Designed for detection of guns as well as knives and other flat or rod-shaped weapons. Meets the Transportation Security Administration's (TSA) Enhanced walk-through Metal Detector (EMD) requirements and exceeds FAA requirements. Provides good discrimination against innocuous items such as coins, keys, jewelry, cigarette packs, foil, etc. Recommended for applications requiring comprehensive detection of guns and knives while providing moderate traffic throughput with low-to-moderate nuisance alarms.
Prisons	A specialized weapons detection program designed to detect all metals and provide the highest level of security available. Exceeds FAA and TSA detection requirements. Provides no discrimination against innocuous items and is therefore recommended for applications which allow low traffic throughput.
Loss Prev1 Loss Prev2 Loss Prev3 Loss Prev4 Loss Prev5 Loss Prev6	Loss prevention programs one to six are used to detect metals ranging from conductive and / or non-ferrous to non-conductive and / or ferrous respectively. Loss Prev1 is designed to detect all metals, particularly good conductors, such as jewelry, computer components and most coins. Loss Prev2 is similar to Loss Prev1 except it is designed to ignore poor conductors, such as cigarette or chewing gum foil and keys. Loss Prev3 to 6 are designed to detect items that are increasingly less conductive and more ferrous (i.e., contain more iron), e.g., Loss Prev3 to 5 detects most weapons; Loss Prev 6 is most recommended for detecting steel tools. Low-moderate throughput.
Alternate	For use as an alternative under difficult environmental conditions, including electrical interference. A general weapons program that provides moderate discrimination against pocket items while offering the best balanced response to all metals. Meets FAA requirements (i.e., three-gun test). Moderate throughput. See Figure 4-1 for a graph representing the trends in detection capabilities of Loss Prevention applications, Loss Prev1 to Loss Prev6.

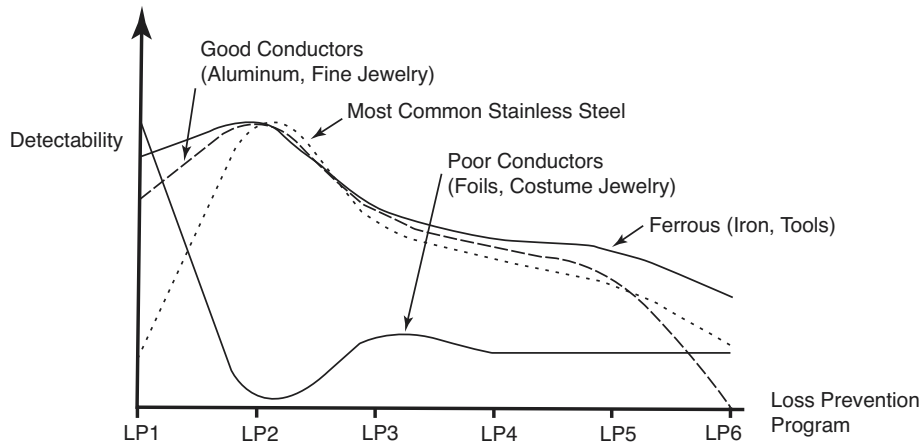

FIGURE 4-1

5. MAINTENANCE / TROUBLESHOOTING

5.1 WARRANTY INFORMATION

Garrett Electronics, Inc. ("Garrett") warrants that each piece of security equipment manufactured by Garrett is protected by the following limited parts and labor warranty for a period of 24 (twenty-four) months (the "Warranty"). During this 24-month period Garrett will inspect and evaluate all equipment returned to its authorized repair station or factory to determine if the equipment meets Garrett's performance specifications. Garrett will repair or replace at no charge to the owner all parts determined faulty. This Warranty does not cover batteries nor any and all failures caused by abuse, tampering, theft, failure due to weather, battery acid or other contaminants and equipment repairs made by an unauthorized party.

THIS WARRANTY IS EXPRESSLY IN LIEU OF ALL OTHER WARRANTIES, EXPRESSED OR IMPLIED, INCLUDING THE WARRANTY OF MERCHANTABILITY OR FITNESS FOR A PARTICULAR PURPOSE.

THE BUYER ACKNOWLEDGES THAT ANY ORAL STATEMENTS ABOUT THE MERCHANDISE DESCRIBED IN THIS CONTRACT MADE BY SELLERS' REPRESENTATIVES, IF ANY SUCH STATEMENTS WERE MADE, DO NOT CONSTITUTE WARRANTIES, SHALL NOT BE RELIED UPON BY THE BUYER, AND ARE NOT A PART OF THIS CONTRACT FOR SALE. THE ENTIRE CONTRACT IS EMBODIED IN THIS WRITING. THIS WRITING CONSTITUTES THE FINAL EXPRESSION OF THE PARTIES' AGREEMENT AND IS A COMPLETE AND EXCLUSIVE STATEMENT OF THE TERMS OF THIS AGREEMENT.

The parties agree that the Buyers' sole and exclusive remedy against Seller shall be for the repair and replacement of defective parts. The Buyer agrees that no other remedy (including, but not limited to, incidental or consequential damages for lost sales, lost profits, injury to person or property) shall be available to him.

5.2 REPAIR

The PD 6500i's modular design facilitates assembly and maintenance.

If problems are site-related, see Section 2.1 or contact the factory for assistance. Often adjusting or relocating the equipment, or removing nearby objects resolves problems.

If the equipment does not perform properly, contact the factory for assistance.

5.2.1 CONTROLLER MODULE

The controller module, located in the overhead panel, contains all of the circuit boards required for operation. The cables that connect the controller module to the side panels are plugged into connectors at the top of each panel. The controller module cover should not be removed except to:

- Connect wires to remote alarm relays or synchronization circuitry (See Section 6.2);
- Attach the battery pack module (See Section 6.1);
- Revert access codes to factory setting. (See Section 3.6)
- Attach remote console or CMA Interface Module.

5.2.2 POWER MODULE

The power module supplies the power required for operation. Ensure that the power cord is plugged into the connector on the lower left side of the module.

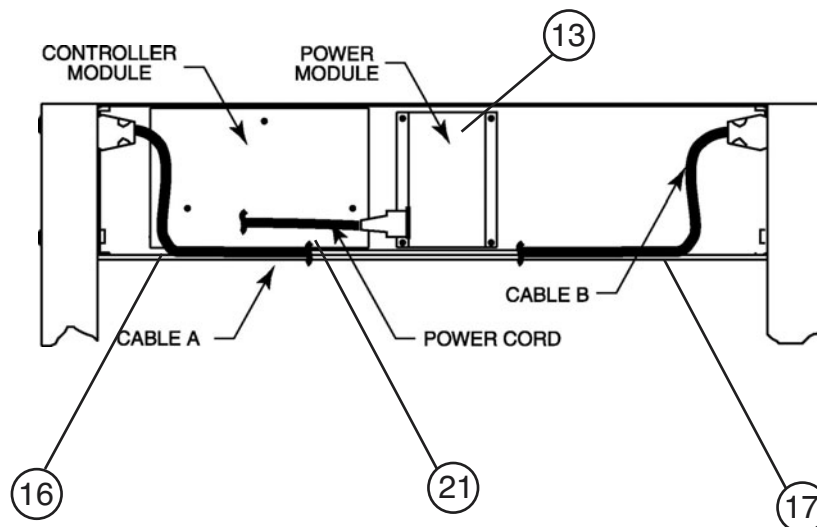

FIGURE 5-1

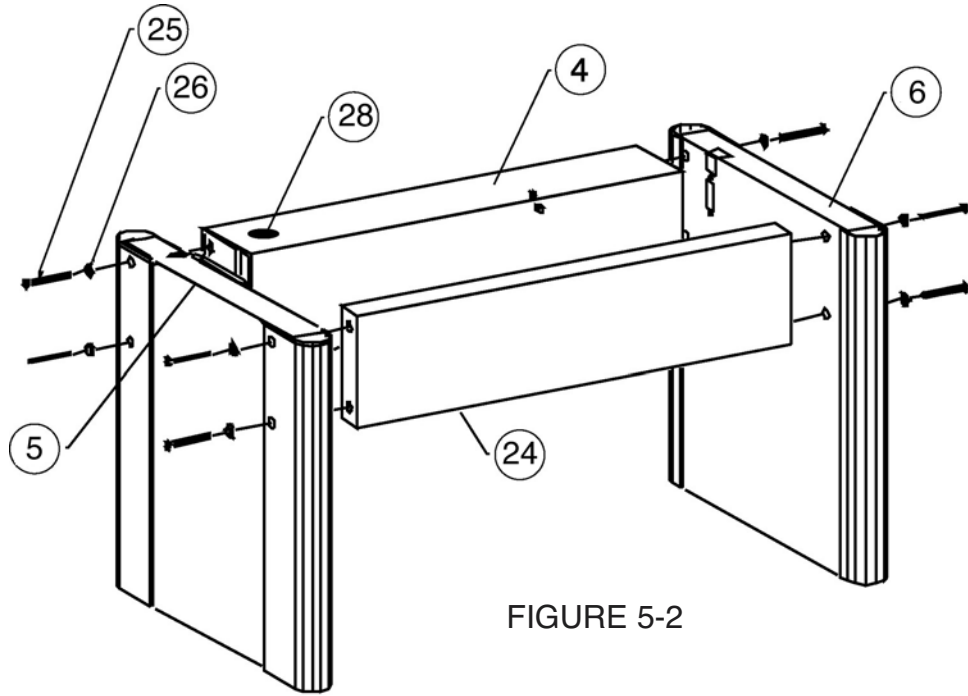

FIGURE 5-2

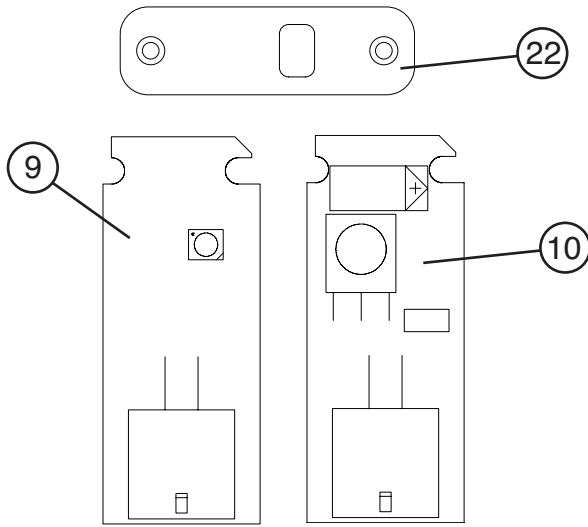

FIGURE 5-3

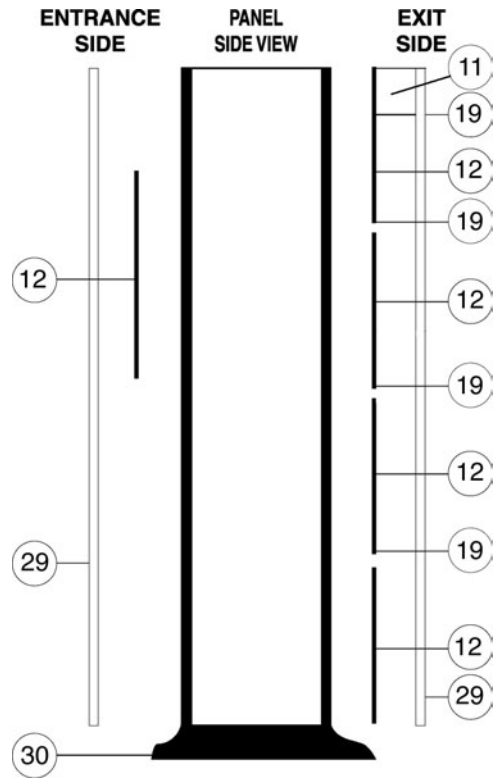

FIGURE 5-4

**GARRETT PD 6500i
USER MANUAL**

5.3 REPLACEMENT PARTS LIST

TABLE 5-3

ITEM	DESCRIPTION	PART #	QTY
1	Access Code Card	1562300	2
2	User's Manual	1532010	1
3	VHS Video Tape	1678400	1
4	Detection Unit	2233450	1
5	Panel A Fin	2233200	1
6	Panel B Fin	2233300	1
7	TX/Controller Board Pcb Assembly	2340500	1
8	RX Pcb Assembly	2340700	2
9	IR Emitter Pcb Assembly	2342000	1
10	IR Detector Pcb Assembly	2342100	1
11	Light Bar Controller	2341100	2
12	Light Bar Slave Set	2341200	2
13	Power Supply Module With Cover	2338602	1
14	Touchpanel	9425100	1
15	Speaker Assembly	2404900	1
16	Cable Assembly A Det Unit (Short)	2421000	1
17	Cable Assembly B Det Unit (Long)	2421100	1
18	Ribbon Cable 40 x 3.5 (Tx-Rx)	2416800	1
19	Flex Strip Jumper 14 x 1.2	2420600	8
20	Power Cord 110V 17'	9411500	1
21	AC Cord Jumper	9427600	1
22	Power Cord - Euro Plug	9421300	1
23	Crosspiece	9968800	1
24	Screw 1/4-20x3	9820400	8
25	Finishing Washer	9820500	8
26	Mount IR Emitter/Detector	9844500	2
27	Hole Plug	9832300	1
28	Extrusion Lens	9999200	4
29	Boot Panel	9999900	2
30	Floor Mounting Kit	1604100	1

5.4

ERROR CODE TABLE-DIAGNOSTICS
CRITICAL FAILURES AND NON-CRITICAL FAILURES

Failures are classified as either "critical" or "non-critical". A critical failure prevents the PD 6500i from operating and must be corrected immediately. When a critical failure occurs, the audio alarm sounds, the overhead display begins flashing and the message, SYSTEM FAILURE, appears on the LCD.

A non-critical failure does not prevent the PD 6500i from operating; however, it should be corrected as soon as possible.

CRITICAL FAILURES	NON-CRITICAL FAILURES
<ul style="list-style-type: none"> • TX A or B FAIL • POWER MOD FAIL • RX BOARD FAIL • RX A or B ZN # PK FAIL • CABLE MISCONNECT • DSP FAIL 	<ul style="list-style-type: none"> • NO SLAVE OUTPUT • SLAVE SYNC • AC SYNC or SYNC FAIL • RX or TX OPTIC FAIL • RX A or B ZN # BAL FAIL

TABLE 5-4

Self Test: Possible Failures and Remedies		
Failure	Verify and/or replace	Special Note
*TX A FAIL	<ol style="list-style-type: none"> 1. Panel A cables & connectors 2. Transmitter control (TX) board 3. Panel A 	
*TX B FAIL	<ol style="list-style-type: none"> 1. Panel B cables and connectors 2. TX board 3. Panel B 	
NO SLAVE OUTPUT	<ol style="list-style-type: none"> 1. Verify connections to slave unit 2. Verify TX board 	
SLAVE SYNC	<ol style="list-style-type: none"> 1. Verify connections from master unit 2. Verify TX board 	
SYNC FAIL	<ol style="list-style-type: none"> 1. Power connections to TX board 2. Power supply module 3. Transmitter control board 	
AC SYNC FAIL	<ol style="list-style-type: none"> 1. Make sure AC power is connected 	Ensure line voltage is between 100 and 240 VAC.
TX OPTIC FAIL	<ol style="list-style-type: none"> 1. Make sure panel cables and PC Board are plugged in 2. IR Emitter board assembly in panel A 	

**GARRETT PD 6500i
USER MANUAL**

Failure	Verify and/or replace	Special Note
RX OPTIC FAIL	<ol style="list-style-type: none"> 1. Make sure panel cables and PC board are plugged in 2. IR Detector board assembly in panel B 	Ensure no blockage of IR beam (of Panel A and Panel B) at waist level of archway.
*POWER MOD FAIL	Power module	Ensure line voltage is between 100 and 240 VAC.
*RXA BOARD FAIL	40-pin cable connection between circuit boards	Check to see all connectors are properly seated.
RXA Zn # BAL FAIL	<ol style="list-style-type: none"> 1. Cable and connector to panel A 2. Circuit Board Connects (# = zone with balance failure) 	Ensure no large metal object nearby. If necessary, move object or relocate PD 6500i.
RXB Zn # BAL FAIL	<ol style="list-style-type: none"> 1. Cable and connectors to panel B 2. Circuit Board Connection (# = zone with balance failure) 	Ensure no large metal object nearby. If necessary, move object or relocate PD 6500i.
*RXA Zn # PK FAIL	<ol style="list-style-type: none"> 1. Panel A cable and connectors 2. Circuit Board Connections 	Ensure no TX A or B FAIL. Ensure no large metal object nearby. If necessary, move object or relocate PD 6500i.
*RXB Zn # PK FAIL	<ol style="list-style-type: none"> 1. Panel B cable and connectors 2. Circuit Board Connections 	Ensure no TX A or B FAIL. Ensure no large metal object nearby. If necessary, move object or relocate PD 6500i.
*CABLE MISCONNECT		Ensure that the cables attached to the circuit boards are connected as described in the inside cover of the controller module.

*Critical failure: PD6500i cannot operate properly. Correct IMMEDIATELY!

6. ACCESSORIES

6.1 BATTERY PACK MODULE (OPTIONAL)

The battery pack module is a field-installable assembly that provides approximately eight hours of uninterrupted operation. A monitoring circuit ensures that the two 12V batteries charge within 12 hours and then switch to trickle charge to ensure maximum charge without battery damage. An alarm warns the operator when batteries are low.

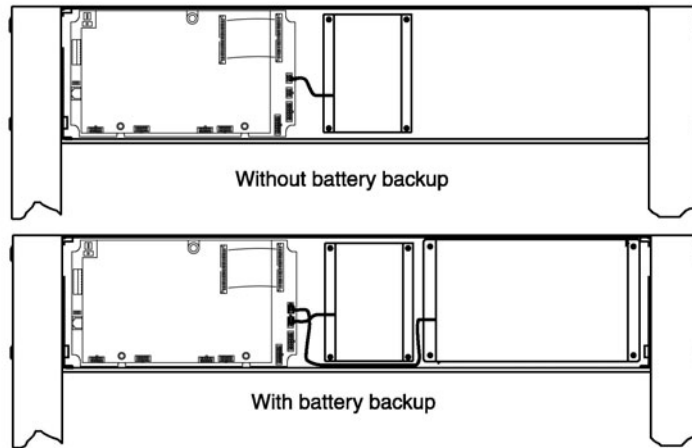

FIGURE 6-1

6.1.1 BATTERY PACK MODULE INSTALLATION

1. Open the access door of the detection unit.
2. Disconnect the AC power plug from the power supply module.
3. Remove the three screws that hold the controller module cover.
4. Remove the four acorn nuts from the package.
5. Install the battery pack module with the acorn nuts.
6. Disconnect the power supply module connector from the controller circuit board. (See Figure 6-1)
7. Reconnect the power supply and battery pack modules. (See Figure 6-1)
8. Reassemble the system and test.

6.2 AC & DC CONTROL

6.2.1 AC CONTROL

To connect an external alarm, a locking device, a VCR/video monitor or other AC component, follow Figure 6-2. The optically-isolated triac output conducts only when the red Alarm light is illuminated. Control should not exceed 48Vrms and 100mA. The output is electrically isolated from ground.

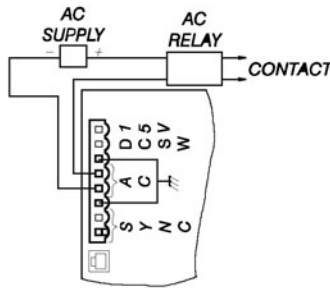

FIGURE 6-2

Procedure:

1. Disconnect from AC power.
2. Open access door of detection unit.
3. Remove the three screws that hold controller cover. Remove the terminal connector.
4. Connect the relay or device to controller circuit board, as shown.
5. Replace terminal connector cover and reconnect power.

6.2.2

DC CONTROL

Cases 1 (internal power), 2 (external power) and 3 (external logic control) (see Figures 6-3, 6-4 and 6-5) show alternatives to connecting an external device that requires a direct, low voltage current. The output is an open collector configuration that can switch 15V at 100mA or less, including connections to computing devices and other equipment requiring low level DC.

Procedure for Cases 1 and 2:

1. Disconnect from AC power.
2. Open access door of detection unit.
3. Remove the three screws that hold controller cover. Remove the terminal connector.
4. Connect the relay or device to controller circuit board, as shown.
5. Replace cover and reconnect power.

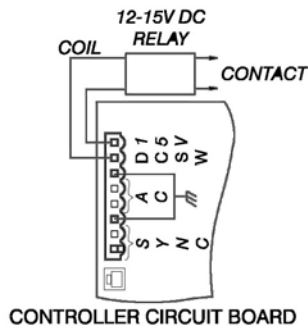

FIGURE 6-3

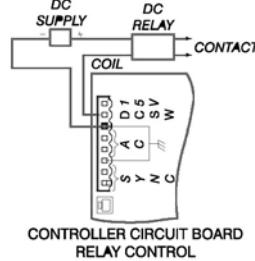

FIGURE 6-4

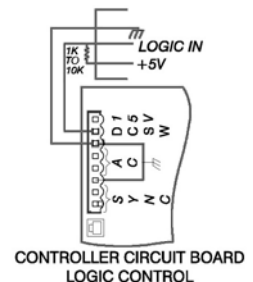

FIGURE 6-5

7.
7.1

**ADDITIONAL INFORMATION
SECURING THE POWER CORD**

Section 2 of this manual describes the connection of the power cord to either side of the base of the unit.

This connection is made with an IEC rated connection that allows easy removal of the unit for maintenance, emergency, etc.

If a more secure attachment of the power cord is required, simply attach the connector and slip the connection back into the panel as shown below.

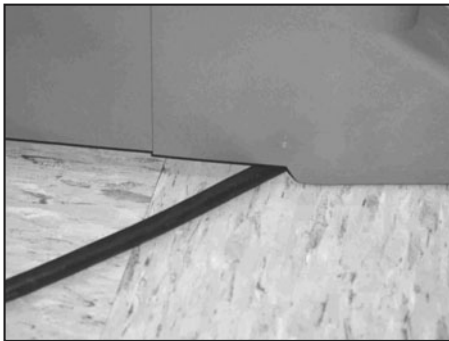
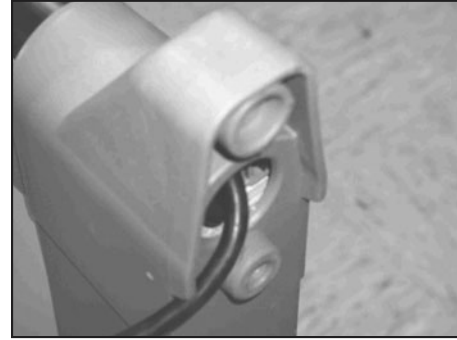
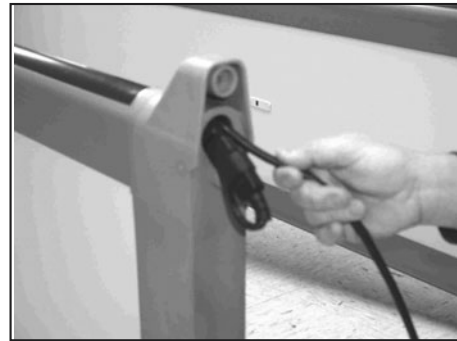

Copyright ©2003 Garrett Metal Detectors. All Rights Reserved

1532010 REV. A