



ST1 / ST1D
User Manual

TABLE OF CONTENTS

INTRODUCTION	1
IMPORTANT PRECAUTIONS	2
ELECTROMAGNETIC INTERFERENCE AND WARNINGS	3
IDENTIFICATION OF PARTS	5
CHARGING THE BATTERIES	9
DISASSEMBLING YOUR SCOOTER	10
TROUBLESHOOTING	12
CAUTION	13
TECHNICAL SPECIFICATIONS	14
INSPECTION CHECKS	15

INTRODUCTION

Thank you and congratulation on purchasing your new 8 fjj Y Medical Ltd. Mobility Scooter. It is designed to provide you with transportation ability indoors and outdoors.

We pride ourselves on providing safe and comfortable products. Our goal is to ensure your complete satisfaction. We sincerely hope you enjoy your new Mobility Scooter.

Please read and observe all warning and instruction provided in owner's manual before you operate with various convenient function of this scooter. Also, please retain this booklet for future reference.

If you have any question, you can contact :

or your local dealer:

Information of European Representative :

EMERGO EUROPE

Molenstraat 15

2513 BH, The Hague

The Netherlands

IMPORTANT PRECAUTIONS

- This scooter is designed for single person use only at any one time.
- Maximum load is 115 kg / 253 lbs.
- Turn key off before getting on or off.
- Always drive carefully and be aware of others using the same area.
- Always use pedestrian crossings wherever possible. Take extreme care when crossing roads.
- Do not drive on slope exceeding 6 degree, and take extreme care when turning on slope.
- Do not use full power when turning to sharp corner.
- Take great care and drive in low speed when backing up, riding downhill or on uneven surface, and climbing curb.
- Please use the lowest speed when driving through the descending road or uneven terrain. If speed is too fast, leave your hand off the handle bar, let the scooter stop. Make sure safety and start again.
- A slow speed must always be used when ascending, descending or traversing aslope or incline and also on uneven terrain, ramps and soft or loose surfaces, such as gravel or grass.
- To prevent any danger, do not turn around at high speed on ascending, descending ramp.
- Scooter may not operate well in high humidity.
- Do not leave the powered scooter in a rain storm of any kind.
- Do not use the powered scooter in a shower.
- Direct exposure to rain or dampness will cause the scooter to malfunction electrically and mechanically; may cause the powered scooter to prematurely rust.
- Never put scooter in neutral when staying on slopes.
- Follow traffic laws when riding outside.
- When scooter on moving transport vehicles, do not sit or stay on scooter.

ELECTROMAGNETIC INTERFERENCE AND WARNINGS

CAUTION : It is very important that you read this information regarding the possible effects of Electromagnetic Interference on your motorized scooter.

Powered wheelchairs and motorized scooters may be susceptible to electromagnetic interference (EMI), which is interfering electromagnetic energy (EM) emitted from sources such as radio stations, TV stations, amateur radio (HAM) transmitters, two-way radios, and cellular phones. The interference (from radio wave sources) can cause the motorized scooter to release its brakes, move by itself, or move in unintended directions. It can also permanently damage the motorized scooter control system. The intensity of the interfering EM energy can be measured in volts per meter (V/m). Each motorized scooter can resist EMI up to certain intensity. This is called its "immunity level." The higher the immunity level, the greater the protection. At this time, current technology is capable of achieving at least a 20 V/m immunity level, which would provide useful protection from the more common sources of radiated EMI. This immunity level of this motorized scooter model is 30 V/m.

There are a number of sources of relatively intense electromagnetic fields in the everyday environment. Some of these sources are obvious and easy to avoid. Others are not apparent and exposure is unavoidable. However, we believe that by following the warnings listed below, your risk to EMI will be minimized.

The sources of radiated EMI can be broadly classified into three types :

1. Hand-held portable transceivers (transmitters-receivers) with the antenna mounted directly on the transmitting unit. Examples include: citizens band (CB) radios, "walkie talkie," security, fire, and police transceivers, cellular telephones, and other personal communication devices;



Some cellular telephones and similar devices transmit signals while they are ON, even when not being used.

2. Medium-range mobile transceivers, such as those used in police cars, fire trucks, ambulances, and taxis. These usually have the antenna mounted on the outside of the vehicle; and
3. Long-range transmitters and transceivers such as commercial broadcast transmitters (radio and TV broadcast antenna towers) and amateur (HAM) radios.



Other types of hand-held devices, such as cordless phones, laptop computers, AM/FM radios, TV sets, CD players, and cassette players, and small appliances, such as electric shavers and hair dryers, so far as we know, are not likely to cause EMI problems to your motorized scooter.

Motorized Scooter Electromagnetic Interference :

Because EM energy rapidly becomes more intense as one move closer to the transmitting antenna (source), the EM fields from hand-held radio wave sources (transceivers) are of special concern. It is possible to unintentionally bring high levels of EM energy very close to the motorized scooter control system while using these devices. This can affect motorized scooter movement and braking. Therefore, the warnings listed below are recommended to prevent possible interference with the control system of the motorized scooter.

Warnings :

Electromagnetic interference (EMI) from sources such as radio and TV stations, amateur radio (HAM) transmitters, two-way radios, and cellular phones can affect motorized scooters. Following the warnings listed below should reduce the chance of unintended brake release or motorized scooter movement which could result in serious injury.

1. Do not operate hand-held transceivers (transmitters-receivers), such as citizens band (CB) radios, or turn ON personal communication devices, such as cellular phones, while the motorized scooter is turned ON;
2. Be aware of nearby transmitters, such as radio or TV stations, and try to avoid coming close to them;
3. If unintended movement or brake release occurs, turn the motorized scooter OFF as soon as it is safe;
4. Be aware that adding accessories or components, or modifying the motorized scooter, may make it more susceptible to EMI; and



There is no easy way to evaluate their effect on the overall immunity of the motorized scooter.

5. Report all incidents of unintended movement or brake release to the distributor listed on the inside front cover of this manual. Note whether there is a source of EMI nearby.

Important Information :

1. 20 volts per meter (V/m) is a generally achievable and useful immunity level against EMI (as of May 1994). The higher the level, the greater the protection.
2. The immunity level of this product is 30 V/m.

IDENTIFICATION OF PARTS

Before attempting to drive this scooter on your own, it is important that you familiarize yourself with the controls, and how to operate them.

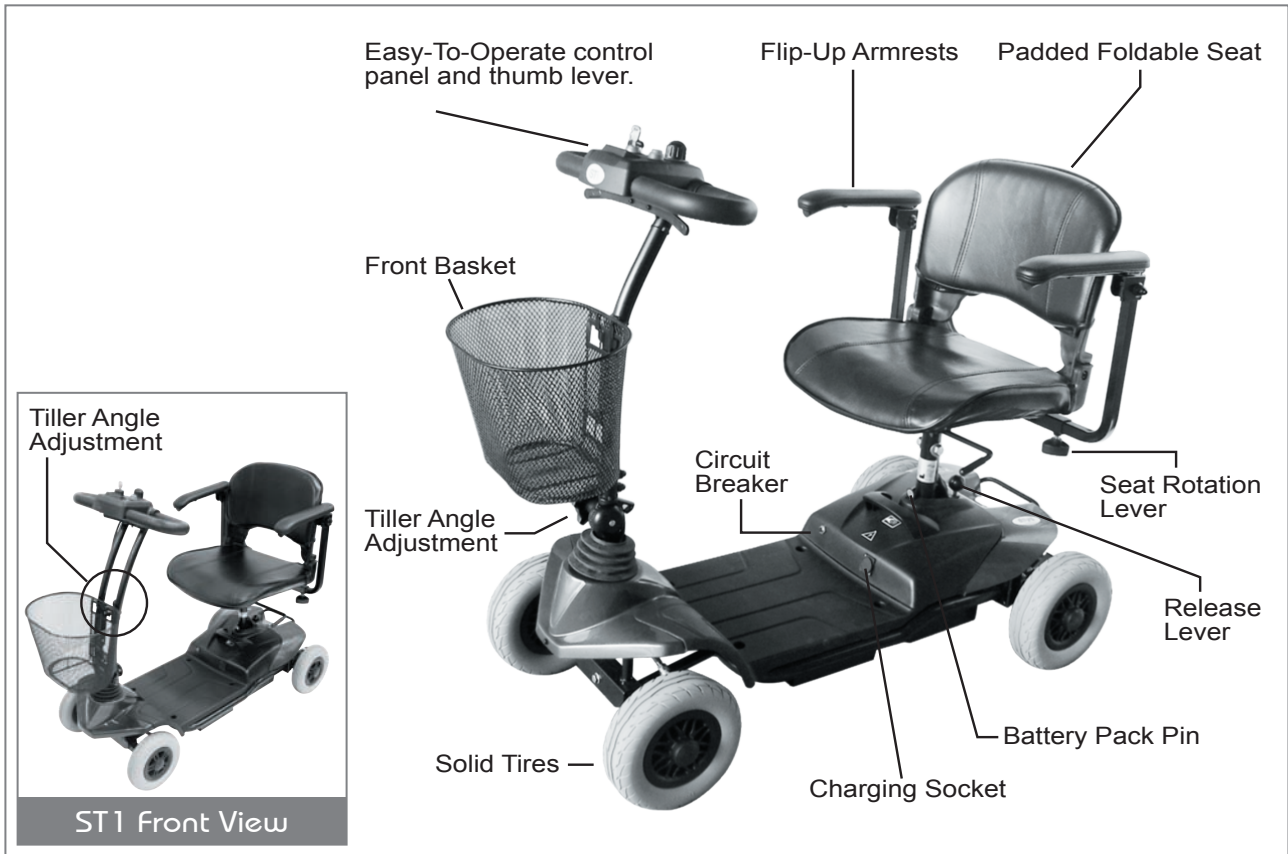

Figure 1 - ST1D Front View

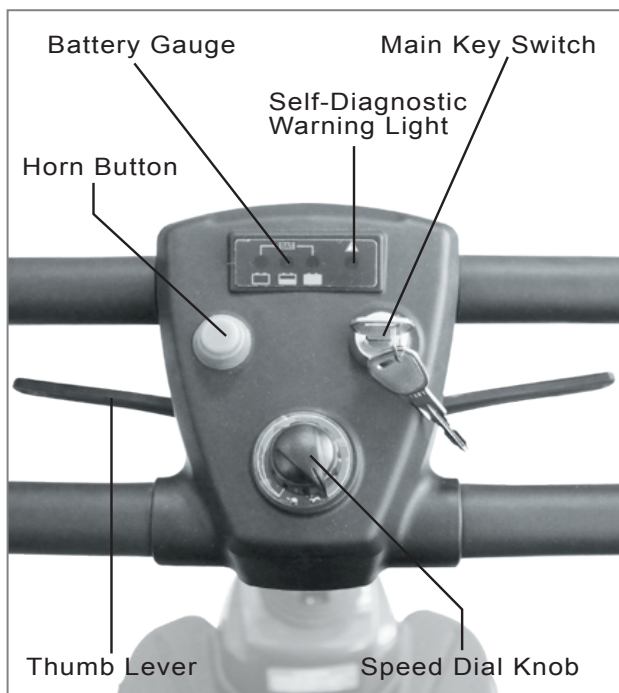

Figure 2 - ST1 Top Control Panel



Figure 3 - ST1D Back View

FUNCTION OF PARTS :**Main Key Switch (A)**

1. Turn the key to the right - Turn the scooter on
2. Turn the key to the left - Turn the scooter off



Always ensure that the scooter is switched off before getting on or off the scooter and before removing any items of the scooter.



The ON/OFF key switch must only be operated, when in motion, in an emergency. Turning the scooter OFF whilst driving will bring the scooter to an abrupt stop.

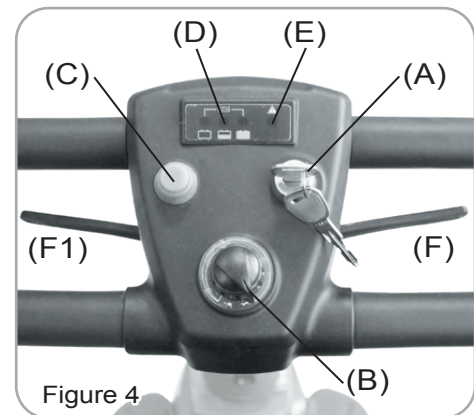

Figure 4

Speed Dial Knob (B)

The image of rabbit means fast or high speed. The image of turtle means slow or low speed. By turning this knob towards chosen image you can control overall speed of the scooter.



Before driving the scooter, set the speed to low speed by turning the knob towards turtle image,



Drive in high speed when encounter an up slope, and drive in slow speed when encounter a down slope.

Horn Button (C)

Press horn button once to sound warning tone when necessary.

Battery Gauge (D)

The meter gives an approximation of battery strength. Three green lights indicate that the batteries are fully charged. Green lights will go out as the batteries are used. When the red light turns on, the batteries need to be charged immediately.

Self Diagnostic Warning Light (E)

Flashing light indicates there is a problem within scooter. See page 12 for more information.

Thumb Lever (F) (F1)

Pulling right thumb lever moves scooter forward. (F) Pulling left thumb lever moves the scooter backward. (F1) (This can be reversed if required by local dealer.) Releasing both, engages automatic brake. These are also your accelerator. The further you depress them, the faster you go. (Subject to the position of the Rabbit/Turtle control).



Releasing the thumb lever engages the automatic brake, but will taxi for a short buffering distance, please keep safe distance when stopping to prevent any danger.

Tiller Angle Adjustment :

- ST1** - 1.Lift up the lever (G) to disengage the pin.
2.Simultaneously, adjust the steering fore-aft to the most comfortable angle. Release lever (G) and ensure the pin is fully engaged to lock the steering column in position.

ST1D - Rotate Hand Wheel Tiller Angle Adjustment (G1) counterclockwise to adjust tiller down. Rotate Wheel clockwise to lock tiller.

Seat Rotation Adjustment :

- 1.Lift lever G, G1 upward to disengage pin.
2.Simultaneously, rotate seat (or lift up to disassemble the seat) to the most comfortable angle. Release lever (H) and ensure the pin is fully engaged to lock the seat in position.

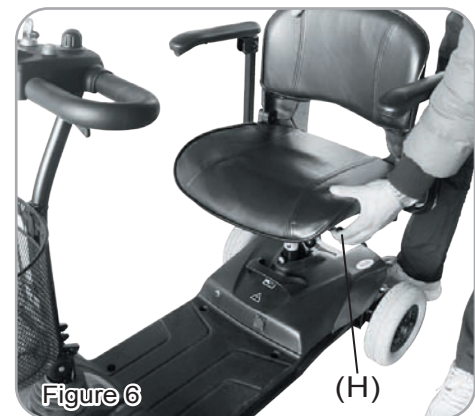
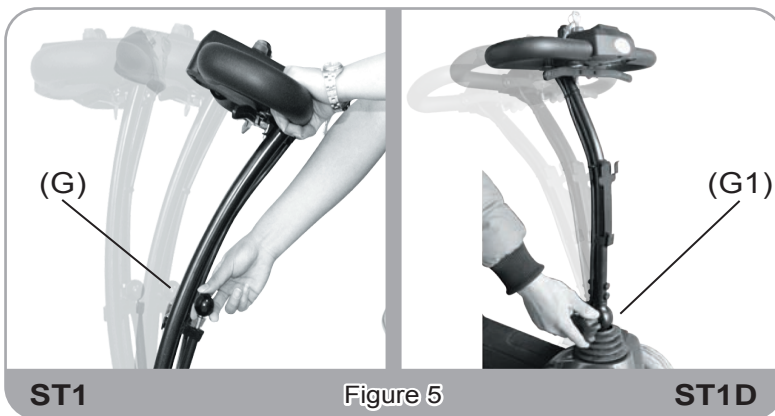
**Circuit Breaker :**

If scooter's circuit system malfunctions or over loaded, the circuit system will automatic shut down the power to ensure driver's safety. After the power is off, press button (J) to regain power.

Free-Wheel Lever :

To push scooter for short distances, put it in freewheel mode by pushing forward on free-wheel lever to N. This disables the drive system and brake system. To take the scooter out of freewheel mode, pull the free-wheel lever backward to D to re-engage the drive and brake system. (J1)

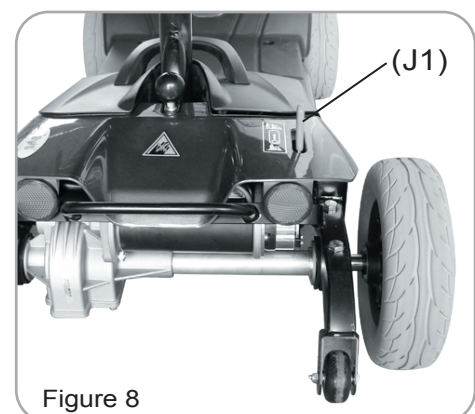
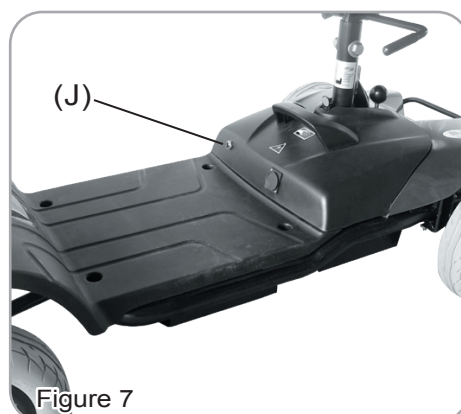

Accessories :**Basket assembling and disassembling :**

Remove the Front Basket (J2) and place it off to the side.

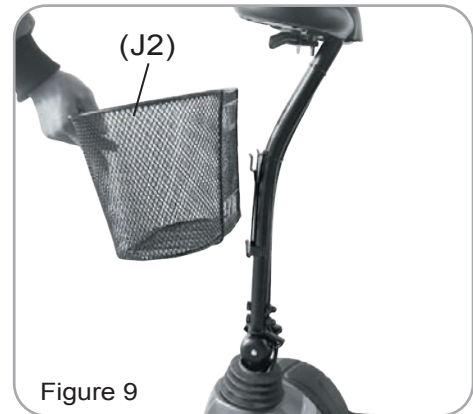

Figure 9

Armrest assembling and angle adjustment :

1. Remove plugs (J3) at both sides.
2. Assembling armrests.
3. Adjust armrest to most comfortable angle, then lock with knob (J4).
4. Adjust screw's (J5) height, to control armrest's angle.

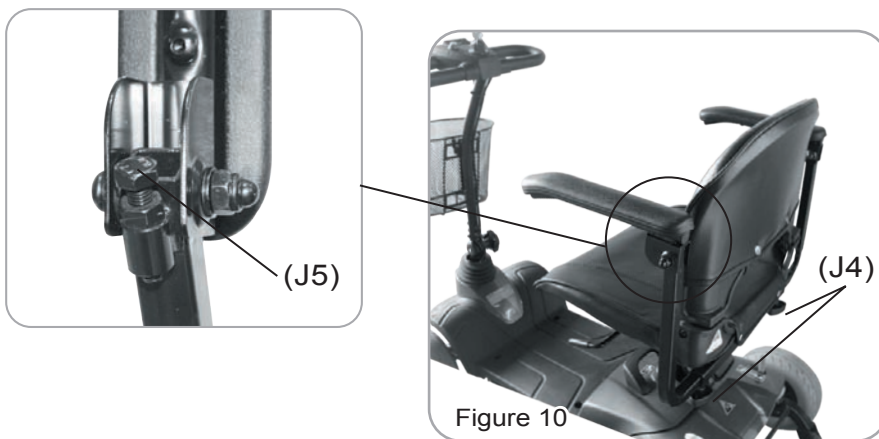

Figure 10

Seat Height adjustment :

1. Remove the seat, and then remove screw, nut and washer from seat post.
2. Adjust seat post to desired height, then attached tightly with screw, nut and washers.
3. Assemble the seat back to its original position.
4. 520mm / 540mm / 560mm measured from ground.
370mm / 390mm / 410mm measured from foot panel on scooter.

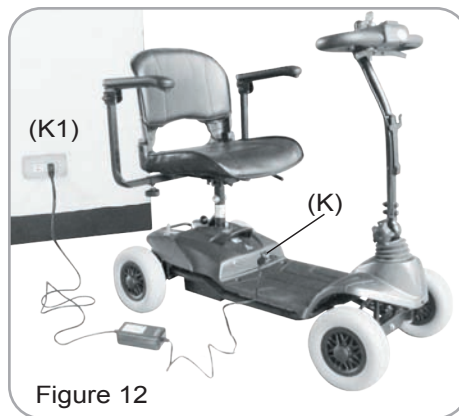

Figure 11

CHARGING THE BATTERIES

Your ST1D scooter is equipped with two sealed, maintenance free 12V. 12Ah. rechargeable batteries and one 24V/1.8A charger. Batteries must be charged before using scooter for first time and should be recharged after each day's use. Be sure power switch is in OFF position and free-wheeling lever is not in freewheel mode.

1. Insert battery charger cord into Charging Socket (K) on battery pack.



2. Plug other end of power cable into a standard electrical wall outlet. (K1)

3. The charging indicator will normally be red or yellow at this point.

4. Allow batteries to charge until charging indicator turns green.

5. After indicator turns green, unplug battery charger from scooter and wall outlet.

6. If at any time battery charger light flashes green over 40 minutes, this indicates abnormal charging occurred. You should check the following:

- Charger plug is correctly positioned
- Scooter is turned off
- If none of these are the problems, contact your local authorized dealer.



The time needed to recharge will vary depending on the depletion of the batteries. Charging for longer than necessary will not harm the batteries. They can not be overcharged.

DISASSEMBLING YOUR SCOOTER

I. Seat Disassembling :

Remove seat by pulling up Seat Rotation Lever (H). Then lift up away from scooter.

II. Battery Pack Disassembling :

As indication, Push Release Lever (L) backward and pull Battery Pack Handle (M) to remove batteries from scooter. Caution: batteries are heavy. When lifting please use correct lifting posture to avoid injury. Ask for assistance if necessary.



When assembling battery pack (M), make sure to aim for the battery terminal connection for proper electricity conductivity.



Figure 13

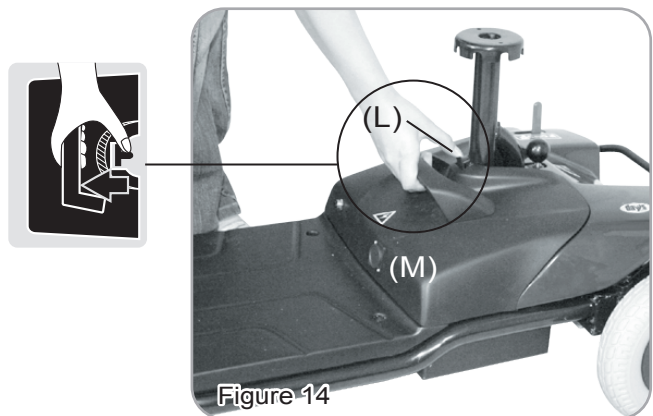

Figure 14

III. Front & Rear Frame Disassembling :

Lift up front & rear frame's fixation pin (N); and hold and pull rear frame as arrow indicates direction to disassembling front and rear frame.



To prevent shroud damage, do not lean disassembled rear frame forward.

When assembling front & rear frame, align left and right sides' stickers and push in to complete the assembly.

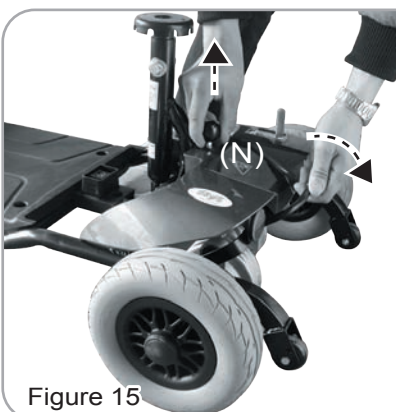
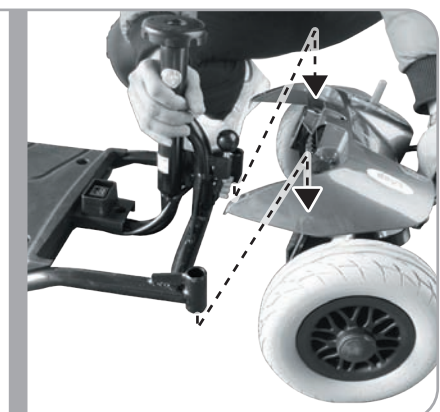
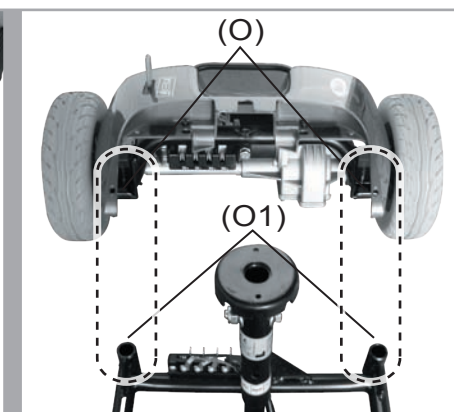

Figure 15



Steering Fold Method :

ST1 - Lift up the lever (G) to bend down the steering to the lowest hole position and fold down the steering column as shown in Figure 16.

ST1D - Rotate Hand Wheel Tiller Angle Adjustment (G1) counterclockwise to adjust tiller down. Rotate Wheel clockwise to lock tiller.(See Fig. 16)

! Re-assembling your scooter by vise versa above disassembling procedures.

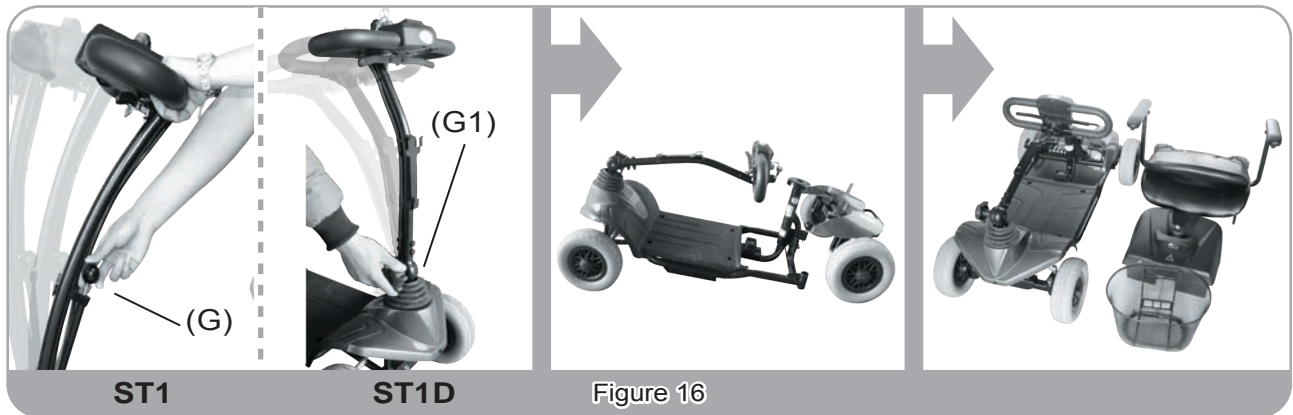

Fuse Replacement :

- 1.Remove front shroud's 5 screws (be careful screws' size are different); lift up front shroud (P) as arrow indicates direction.
- 2.Open fuse box (P1) and replace with backup fuse (P2).

! Replace with same power fuse is required. After replacement, vise versa assembling procedure to original condition.

Rim Disassembling :

- 1.By using a screw driver, to lift up rim (Q).

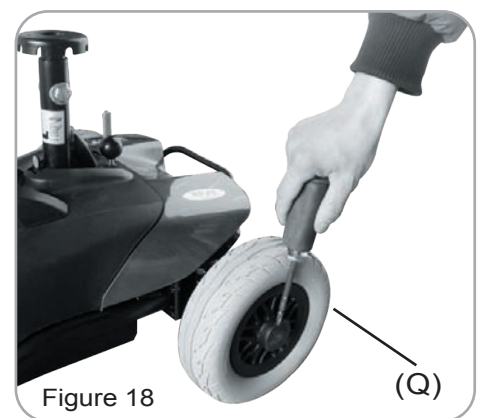
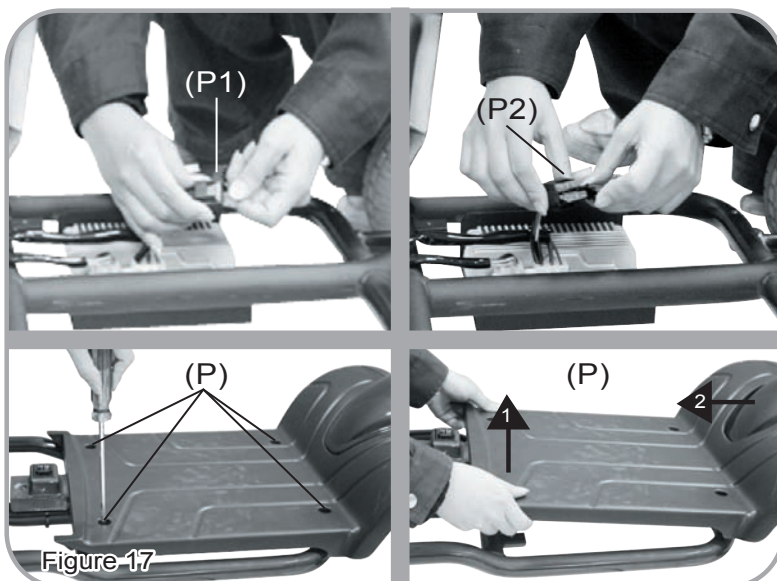

TROUBLESHOOTING

Flash	Description	Meaning
1	Battery Low	The batteries are running low. <ul style="list-style-type: none"> • Recharge the batteries
2	Low Battery Fault	The batteries have run out of charge. <ul style="list-style-type: none"> • Recharge the batteries.
3	High Battery Fault	Battery voltage is too high. This may occur if overcharged &/or traveling down a long slope. <ul style="list-style-type: none"> • If traveling down a slope, reduce your speed to minimize the amount of regenerative charging. • Check the battery and associated connections and wiring.
4	Current Limit Time-out	The motor has been exceeding its maximum current rating for too long. This may be due to a faulty motor. <ul style="list-style-type: none"> • Check the motor and associated connections and wiring. • Turn the controller off, leave for a few minutes and turn back on again.
5	Park Brake Fault	Either a park brake release switch is active or the park brake is faulty. <ul style="list-style-type: none"> • Check the park brake and associated connections and wiring. • Ensure any associated switches are in their correct positions.
6	Throttle OONAPU	The Throttle is out of neutral when turning the controller on. <ul style="list-style-type: none"> • Ensure the throttle is in neutral when turning the controller on. • The Throttle may require re-calibration.
7	Speed Pot Fault	The throttle, speed limit pot or their associated wiring may be faulty. <ul style="list-style-type: none"> • Check the throttle and speed pot and associated connections and wiring.
8	Motor Voltage Fault	The motor or its associated wiring is faulty. <ul style="list-style-type: none"> • Check the motor and associated connections and wiring.
9	Other error	The controller may have an internal fault. <ul style="list-style-type: none"> • Check all connections & wiring.

CAUTION**1. Obstacle Climbing :**

Your scooter can climb obstacles and curbs of up to 35mm in height. Never attempt to overcome an obstacle when on an uphill or downhill gradient! Always approach obstacles straight on! Ensure that the front wheels and rear wheels move over the obstacle in one stroke, do not stop halfway!

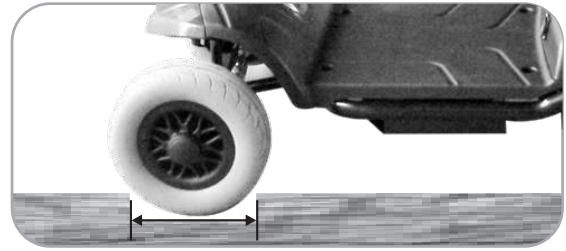
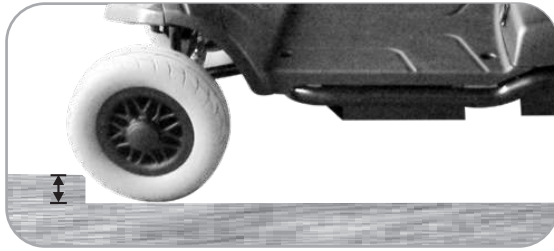
2. The maximum gap the scooter can drive over is 10cm.

- When driving scooter on ramp, adjust body center of gravity to keep scooter more safety.



General driving posture



On ramp, forward your body will let scooter more safety.



In unlikely event of a panel display error, you need to re-set the display system by cycling the on/off main switch. The display circuitry is independent of the motor control system. A display console error does not affect scooter speed control.

OTHER

1. Charge the batteries after each trip. If the scooter is not used for some time, batteries may lose their charge. Batteries should be charged at least once a month.
2. Check the battery gauge before driving to prevent power depletion.
3. Batteries will have an aging phenomenon, where the storage capacity will gradually decrease. If batteries are damaged, please wrap them in a plastic bag and contact your local dealer for proper disposal.
4. Do not disassemble battery and open sealed parts by yourself to prevent electric shock and burns from acid leakage,
5. Adjust speed to a slow speed when starting off to prevent sudden acceleration.
6. Never attempt to drive downhill backwards.
7. Try not to drive scooter at night or in rain or bad weather.
8. If storing your scooter for a long time (1 month or more), make sure that battery are fully charged, then disconnect the two batteries plugs, and the store scooter in a dry location.
9. Front basket, weight capacity 3kgs.

TECHNICAL SPECIFICATIONS

SPECIFICATIONS	ST1	ST1D
Overall Length	1000 mm / 39.4"	1010 mm / 39.8"
Overall Width	510 mm / 20"	540 mm / 21"
Overall Height	890 mm / 35"	920 mm / 36.2"
Wheels: Front	195 mm / 8"	210 mm / 8.3"
Wheels: Rear	195 mm / 8"	210 mm / 8.3"
Weight w/ Batteries	40 kg / 88 lbs	41 kg / 91 lbs
Max. Speed	4 mph / 6.4 km/h @ 15% slope	
Maximum Weight Capacity	115 kg / 253 lbs	
Ground Clearance	35 mm / 1.4"	45 mm / 1.8"
Maximum Safe Slope	6 degree	
Kerb Climbing	35 mm / 1.4"	30 mm / 1.2"
Turning Radius	1270 mm / 50"	
Suspension	N/A	
Brake	Electro-Mechanical	
Seat Type	Padded Foldable	
Seat Width	425 mm / 17"	
Seat Height adjustment	520 mm / 540 mm / 560 mm <small>measured from ground</small>	
	370 mm / 390 mm / 410 mm <small>measured from foot panel on scooter</small>	
Motor Size	250W, 4700 r.p.m.	
Battery	(2) 12V. 12Ah	
Weight of Batteries	8.2 kg / 18 lbs	
Travel Range	10 km / 6.2 Miles	
Battery Charger	1.8A Off Board	
Electronics	On / Off Key Switch, Battery Level Indicator, Speed Control Knob	

*Subject to change without notice.

INSPECTION CHECKS

The following table lists inspection checks that should be performed by the user and their intervals. If the mobility device fails to pass one of the inspection checks, please contact your authorised Ötöb dealer.

Maintenance Jobs	When Delivered	Weekly	Monthly
Seat and backrest padding:			X
- Check for perfect condition.			
Tyres:			
- Have tyres checked for specified air pressure (2,5 bar).	X	X	
Front wheels:			
- Front wheels must spin smoothly.		X	
- If wheels wobble or do not spin easily, adjust steering pivot pin or front wheel bearing.			X
Rear wheels:			
- Test wheel for firm seat on the axle drive shaft.			X
- Rear wheels must spin without wobbling			X
Electronics / Electrical System:			
- Check all plug connections for condition and firm connection.			X
- Have batteries been fully charged before the daily operation?	Before every trip		
- Are all holders, screws firmly fixed, tight and safe?			X
- Are all electric bulbs of the lighting system (if applicable) in working order?	Before each trip		
Cleaning:			
- Clean all parts carefully.	When necessary		

Warranty Information

Drive Medical ST1 and ST1D Scooters are warranted for 12months (24 months frame) from the date of purchase on side frames and crossbars. (NB Batteries are warranted for 12 months.)

- » During the warranty period any parts that have become defective due to faulty workmanship or material will be repaired or replaced without charge by Drive Medical supplier/dealer
- » The warranty excludes tyres, punctures and items that become worn due to normal wear and tear such as upholstery and armrest pads
- » The warranty excludes all items that have been subject to undue wear and tear and misuse
- » Unauthorised changes or modifications will forfeit your warranty
- » If a defect or fault is discovered, the Drive Medical supplier/dealer from whom the Wheelchair was purchased should be notified immediately

Limitation of Liability

The warranty does not extend to the consequential costs resulting from fault clearance, in particular freight and travel costs, loss of earnings, expenses, etc. The manufacturer will not accept responsibility for any damage or injury caused by misuse or non-observance of the instructions set out in this user manual.

Dealer Stamp



Drive Medical Ltd
North Road,
Bridgend Industrial Estate
Bridgend, CF31 3TP

Tel: +44 (0) 1656 664700

Fax: +44 (0) 1656 664727

Email: info@drivemedical.co.uk

www.drivemedical.co.uk